



Chipsmall Limited consists of a professional team with an average of over 10 year of expertise in the distribution of electronic components. Based in Hongkong, we have already established firm and mutual-benefit business relationships with customers from,Europe,America and south Asia,supplying obsolete and hard-to-find components to meet their specific needs.

With the principle of “Quality Parts,Customers Priority,Honest Operation,and Considerate Service”,our business mainly focus on the distribution of electronic components. Line cards we deal with include Microchip,ALPS,ROHM,Xilinx,Pulse,ON,Everlight and Freescale. Main products comprise IC,Modules,Potentiometer,IC Socket,Relay,Connector.Our parts cover such applications as commercial,industrial, and automotives areas.

We are looking forward to setting up business relationship with you and hope to provide you with the best service and solution. Let us make a better world for our industry!



Contact us

Tel: +86-755-8981 8866 Fax: +86-755-8427 6832

Email & Skype: info@chipsmall.com Web: www.chipsmall.com

Address: A1208, Overseas Decoration Building, #122 Zhenhua RD., Futian, Shenzhen, China



AT91RM9200-EK Evaluation Board

User Guide





Table of Contents

Section 1

Overview	1-1
1.1 Scope	1-1
1.2 Deliverables	1-2
1.3 The AT91RM9200-EK Evaluation Board	1-3

Section 2

Setting Up the AT91RM9200-EK Evaluation Board	2-1
2.1 Electrostatic Warning	2-1
2.2 Requirements	2-1
2.3 Powering Up the Board	2-1
2.4 Getting Started with the AT91RM9200	2-1

Section 3

Board Description	3-1
3.1 AT91RM9200 Processor	3-1
3.2 Memory	3-2
3.3 Memory Card	3-2
3.4 Clock Circuitry and Analog Functions	3-2
3.5 Reset Circuitry	3-2
3.6 Power Supply Circuitry	3-2
3.7 Remote Communication	3-2
3.8 User Interface	3-2
3.9 Expansion Slot	3-3
3.10 Debug Interface	3-3
3.11 Wrapping User Area	3-3

Section 4

Configuration Straps	4-1
4.1 Configuration Straps and Jumper Settings	4-1

Section 5

Schematics	5-1
5.1 Schematics	5-1

Section 6

Errata	6-1
6.1 Errata	6-1
6.1.1 SD/MMC Card slot communication problem	6-1



Section 1

Overview

1.1 Scope

The AT91RM9200-EK Evaluation Board enables real-time code development and evaluation. It supports the AT91RM9200 ARM9™-based 32-bit RISC microcontroller.

This guide focuses on the AT91RM9200-EK Evaluation Board as an evaluation and demonstration platform:

- Section 1 is this overview.
- Section 2 gives information on setting up the installation.
- Section 3 contains a description of the development board.
- Section 4 details the configuration straps.
- Section 5 shows board schematics.
- Section 6 contains errata.

1.2 Deliverables

The development kit is delivered with:

- One AC adapter 100 - 240V ~ 1.2A, 12V, 50 - 60 Hz with adapters
 - One modem RS232 cable
 - One RJ45 Ethernet crossed cable
 - One A/B-type USB cable
 - One AT91 DVD-ROM containing summary and full datasheets, datasheets with electrical and mechanical characteristics, application notes and getting started documents for all development boards and AT91 microcontrollers. An AT91 software package with C and assembly listings is also provided. This allows the user to begin evaluating the AT91 ARM[®] Thumb[®] 32-bit microcontroller quickly.
 - CD ROMs from third parties, providing solutions for operating system evaluation
 - DataFlash[®] Cards to provide demonstrations of operating systems when inserted in the bootable slot
- Note:** To boot on a DataFlash Card:
- Ensure J15 (BMS) is set on position 1-2
 - Insert the DataFlash Card in the J200 socket (bottom side)
 - Reset the board

Further details are given on the AT91 DVD-ROM.

Note: These deliverables are subject to change without notice.

-
- 1.3 The AT91RM9200-EK Evaluation Board**
- The board consists of an AT91RM9200 together with the following:
- 8 Mbytes of parallel Flash memory
 - Four banks of 2M x 32-bit SDRAM
 - DataFlash[®] or SD/MMC memory expansion socket
 - Additional DataFlash memory expansion socket
 - Digital-to-Analog Converter (DAC) for a stereo audio signal
 - Four communication ports (USB host and device, Ethernet, serial and DBGU)
 - Graphic controller with output to a standard VGA monitor
 - JTAG/ICE, ETM and code test port interface
 - Expansion connector
 - Onboard prototype area

Figure 1-1. AT91RM9200-EK Evaluation Board Block Diagram

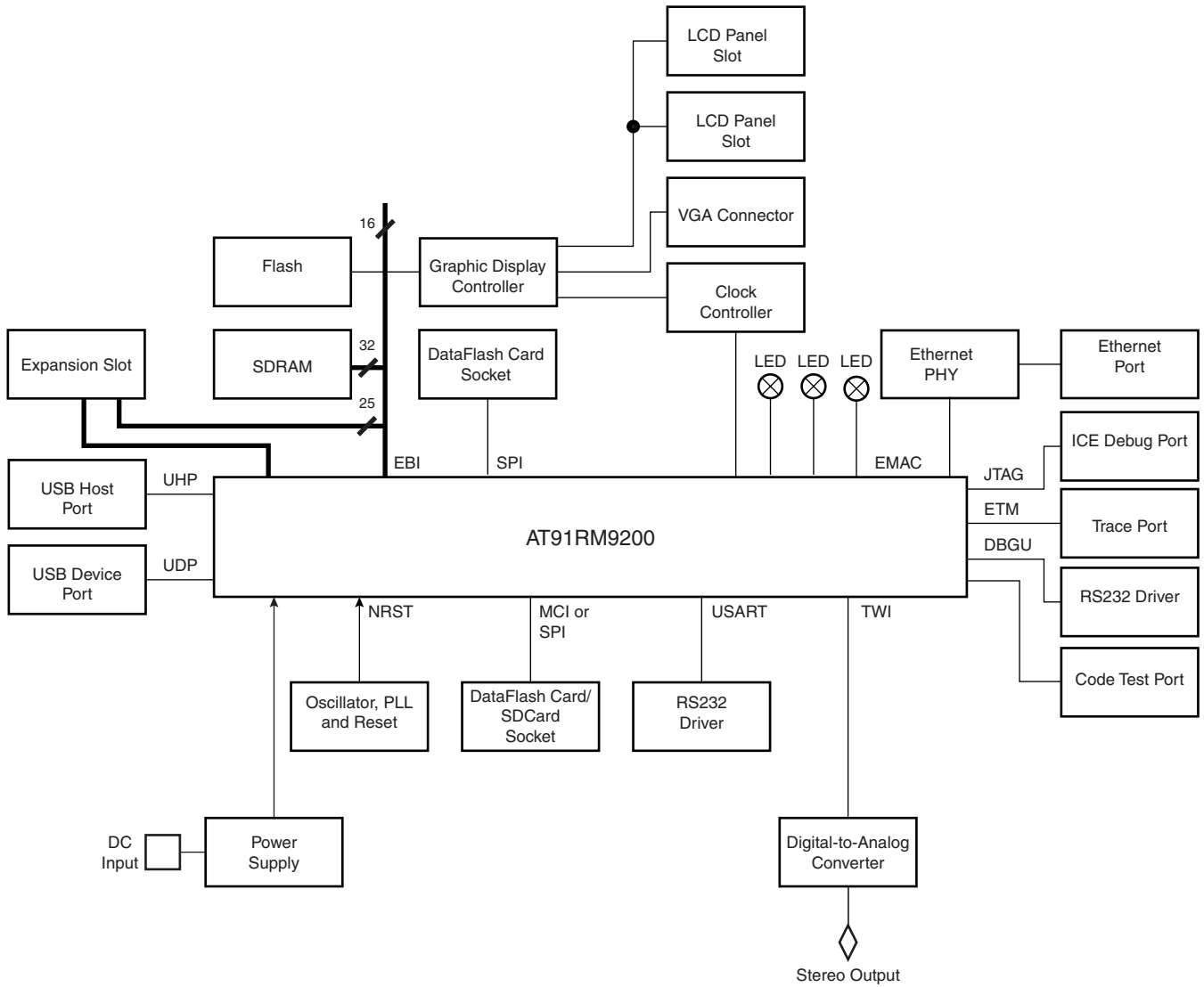



Section 2

Setting Up the AT91RM9200-EK Evaluation Board

-
- 2.1 Electrostatic Warning** The AT91RM9200-EK Evaluation Board is shipped in protective anti-static packaging. The board must not be subjected to high electrostatic potentials. A grounding strap or similar protective device should be worn when handling the board. Avoid touching the component pins or any other metallic element.
-
- 2.2 Requirements** In order to connect the AT91RM9200-EK Evaluation Board, the following element is required:
- The AT91RM9200-EK Evaluation Board itself
-
- 2.3 Powering Up the Board** DC power is supplied to the board via the 2.1 mm socket (J1). The polarity of the power supply is not critical. The minimum voltage required is 7V.
- The board has three voltage regulators providing 1.8V, 3.3V and 5V. The regulators allow the input voltage range to be from 7V to 12V.
-
- 2.4 Getting Started with the AT91RM9200** The AT91RM9200-EK Evaluation Board is delivered with a DVD-ROM containing all necessary information and step-by-step procedures for working with the most common development tool chains. Please refer to this DVD-ROM, or to the AT91 web site, <http://www.atmel.com/products/AT91/> for the most up-to-date information on getting started with the AT91RM9200.





Section 3

Board Description

- 3.1 AT91RM9200 Processor**
- Incorporates the ARM920T™ ARM® Thumb® Processor
 - 200 MIPS at 180 MHz
 - 16-KByte Data Cache, 16-KByte Instruction Cache, Write Buffer
 - Memory Management Unit
 - In-circuit Emulator including Debug Communication Channel
 - Mid-level Implementation Embedded Trace Macrocell™
 - Additional Embedded Memories
 - 16K Bytes of SRAM and 128K Bytes of ROM
 - External Bus Interface (EBI)
 - Supports SDRAM, Static Memory, Burst Flash, Glueless Connection to CompactFlash®, SmartMedia® and NAND Flash
 - System Peripherals:
 - Enhanced Clock Generator and Power Management Controller
 - Two On-chip Oscillators with Two PLLs
 - Very Slow Clock Operating Mode and Software Power Optimization Capabilities
 - Four Programmable External Clock Signals
 - System Timer Including Periodic Interrupt, Watchdog and Second Counter
 - Real-time Clock with Alarm Interrupt
 - Debug Unit, Two-wire UART and Support for Debug Communication Channel
 - Advanced Interrupt Controller with 8-level Priority, Individually Maskable Vectored Interrupt Sources, Spurious Interrupt Protected
 - Seven External Interrupt Sources and One Fast Interrupt Source
 - Four 32-bit PIO Controllers with Up to 122 Programmable I/O Lines, Input Change Interrupt and Open-drain Capability on Each Line
 - 20-channel Peripheral DMA Controller (PDC)
 - Ethernet MAC 10/100 Base-T
 - USB 2.0 Full Speed (12 M-bits per second) Host Double Port and Device Port

- MultiMedia Card Interface (MCI)
- Three Synchronous Serial Controllers (SSC)
- Four Universal Synchronous/Asynchronous Receiver/Transmitters (USART)
- Master/Slave Serial Peripheral Interface (SPI)
- Two 3-channel, 16-bit Timer/Counters (TC)
- Two-wire Interface (TWI)
- IEEE 1149.1 JTAG Boundary Scan on All Digital Pins

-
- 3.2 Memory**
- 8-Mbyte parallel Flash memory
 - Four banks of 2M x 32-bit SDRAM

-
- 3.3 Memory Card**
- SD Card/MMC
 - Supports MultiMedia and SD Card
 - Analog switches provide support for DataFlash[®] Card
 - Additional DataFlash Card Socket

-
- 3.4 Clock Circuitry and Analog Functions**
- 32.768 kHz standard crystal for the AT91RM9200
 - 18.432 MHz standard crystal for the AT91RM9200
 - 50 MHz CMOS oscillator for the Display Controller and Ethernet PHY

-
- 3.5 Reset Circuitry**
- Reset Controller

-
- 3.6 Power Supply Circuitry**
- 5V DC/DC converter
 - 3.3V DC/DC converter
 - 1.8V Linear regulator

-
- 3.7 Remote Communication**
- Fast Ethernet Physical Layer Single Chip Transceiver
 - Host Interface via RS-232 DB9 male socket
 - Debug Port via RS-232 DB9 connector
 - Host and Device USB socket

-
- 3.8 User Interface**
- Graphic Display Controller
 - TFT/SNT panel socket

- 15-pin standard socket for an external VGA monitor
- Three LEDs managed via general PIO lines
- Stereo Audio Jack connected to a DAC

3.9 Expansion Slot ■ The expansion slot gives access to all the microcontroller's signals.

3.10 Debug Interface

- 38-pin trace Port socket (ETM)
- 38-pin Code Test port socket
- 20-pin JTAG ICE interface connector
- Serial Debug Unit

3.11 Wrapping User Area ■ Onboard prototype area allowing the developer to fit additional components.





Section 4

Configuration Straps

4.1 Configuration Straps and Jumper Settings

Table 4-1 gives details on configuration straps and jumper settings on the AT91RM9200-EK Evaluation Board and their default settings.

Table 4-1. Configuration Straps and Jumper Settings

Designation	Default Setting	Feature
J13	Closed	Available for measuring VDDCORE current.
J15	1 - 2	The AT91RM9200 boots from internal ROM and can also boot from external SPI DataFlash [®] connected on NPCS0.
	2 - 3	The AT91RM9200 boots from Flash memory connected on NCS0.



Section 5

Schematics

5.1 Schematics

This section contains the following schematics:

- AT91RM9200-EK Board Layout, Rev. 63PC042262A01 - Top View
- AT91RM9200-EK Board Layout, Rev. 63PC042262A01 - Bottom View
- Power Supply
- AT91RM9200 Chip
- Debug
- SDRAM and Flash
- RMI Ethernet
- Stereo Audio DAC
- Serial Interfaces
- VGA Display
- Expansion Connector

Figure 5-1. AT91RM9200-EK Board Layout, Rev. 63PC042262A01 - Top View

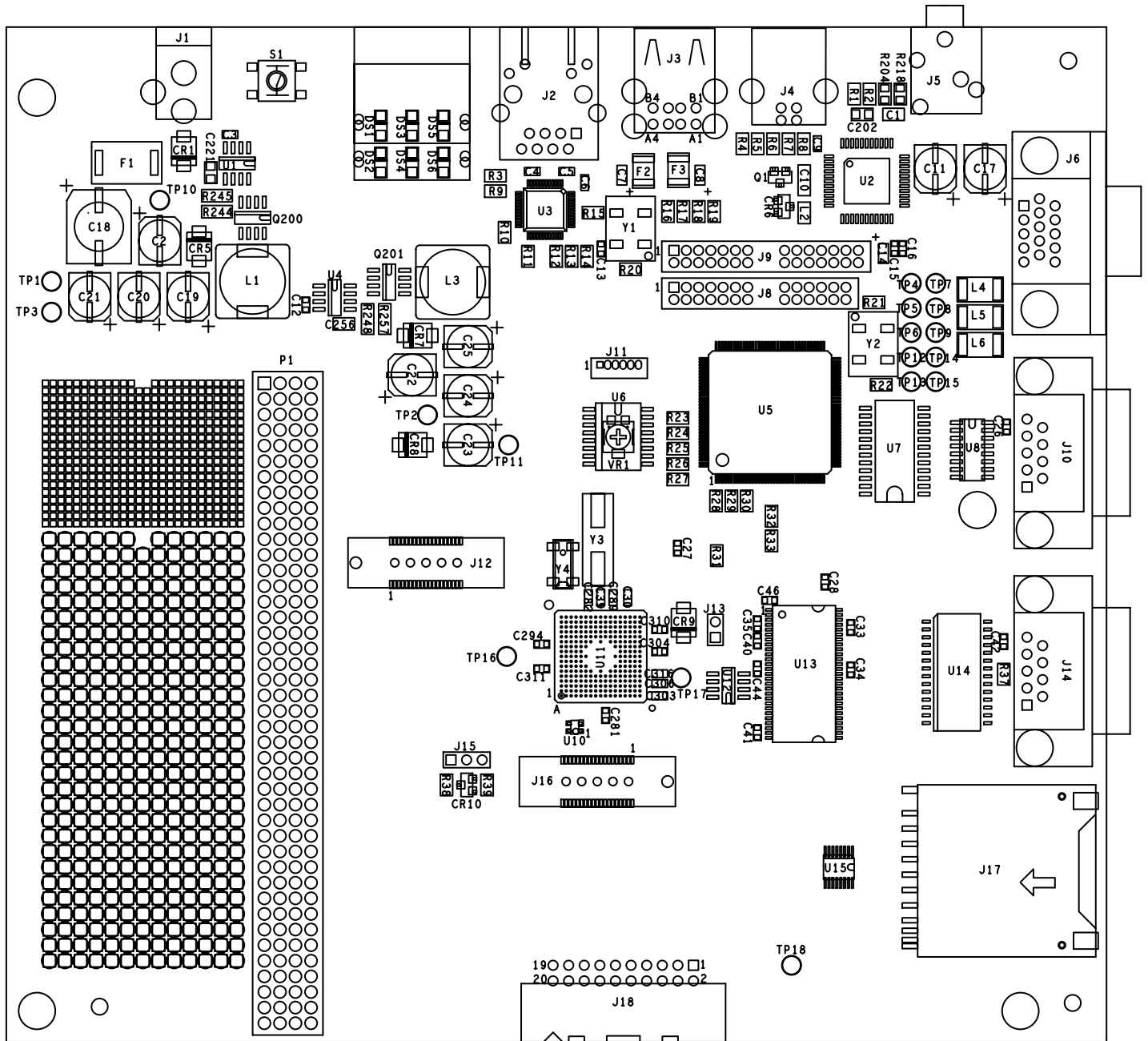
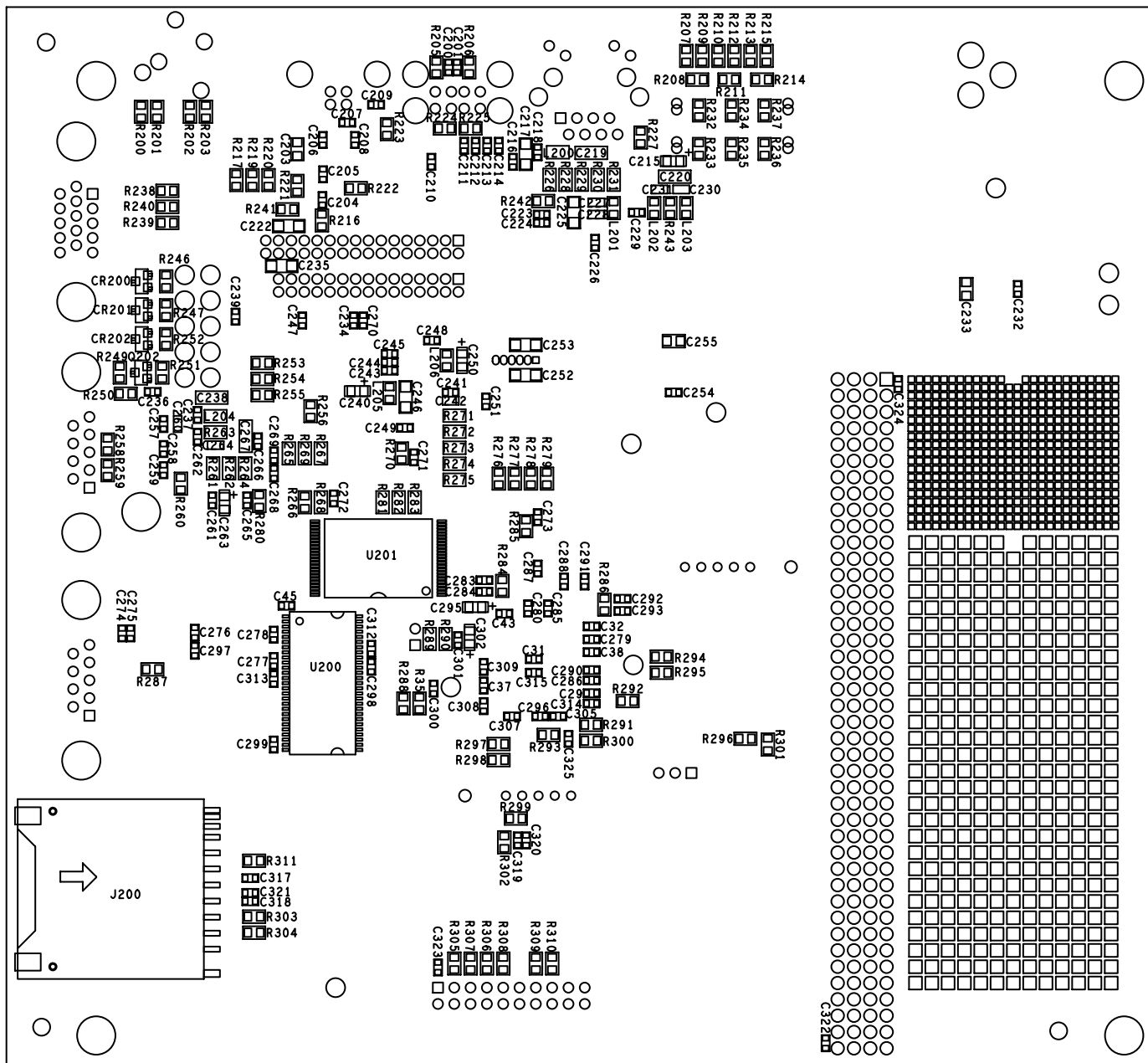
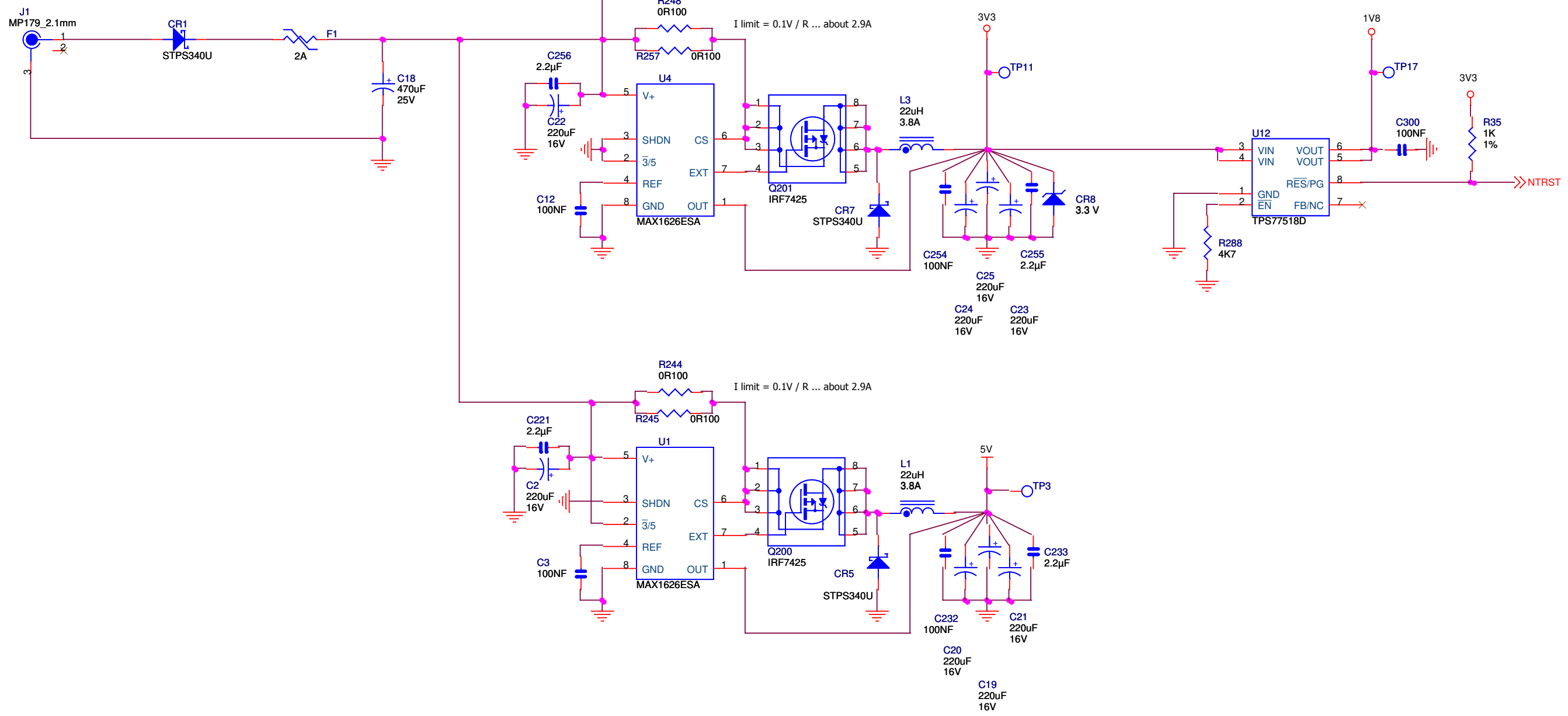

Figure 5-2. AT91RM9200-EK Board Layout, Rev. 63PC042262A01 - Bottom View



12V DC INPUT



Z3 - Z5 are mounting holes.
The Z reference designators
are not listed on the actual
board.

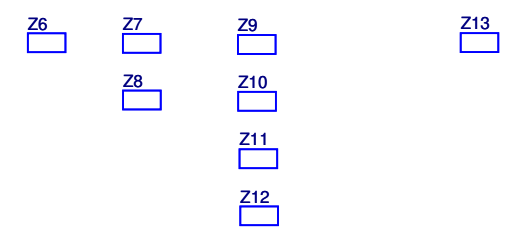
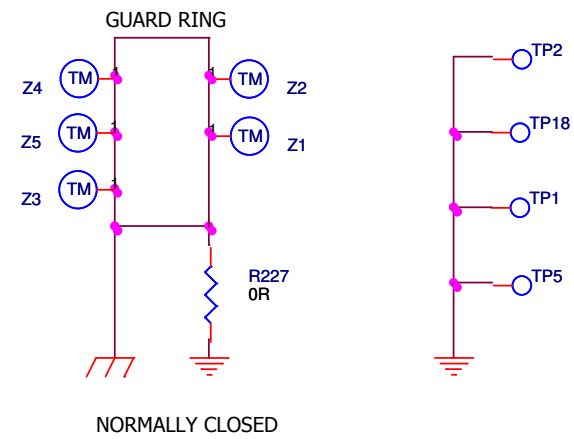

Wednesday, February 23, 2005

ATMEL ROUSSET					
REV	MODIF.	DES.	DATE	VER.	DATE
B	101-3-05-106	ELX	23/02/05	JPG	23/02/05
A	INIT EDIT	MDZ	04/01/05	JPG	06/01/05
AT91RM9200-EK		SCALE 1/1		REV.	SHEET 1/9
POWER SUPPLY		63SC042261		A01	

This agreement is our property. Reproduction and publication without our written authorization shall expose offender to legal proceedings.

AT91RM9200

U11

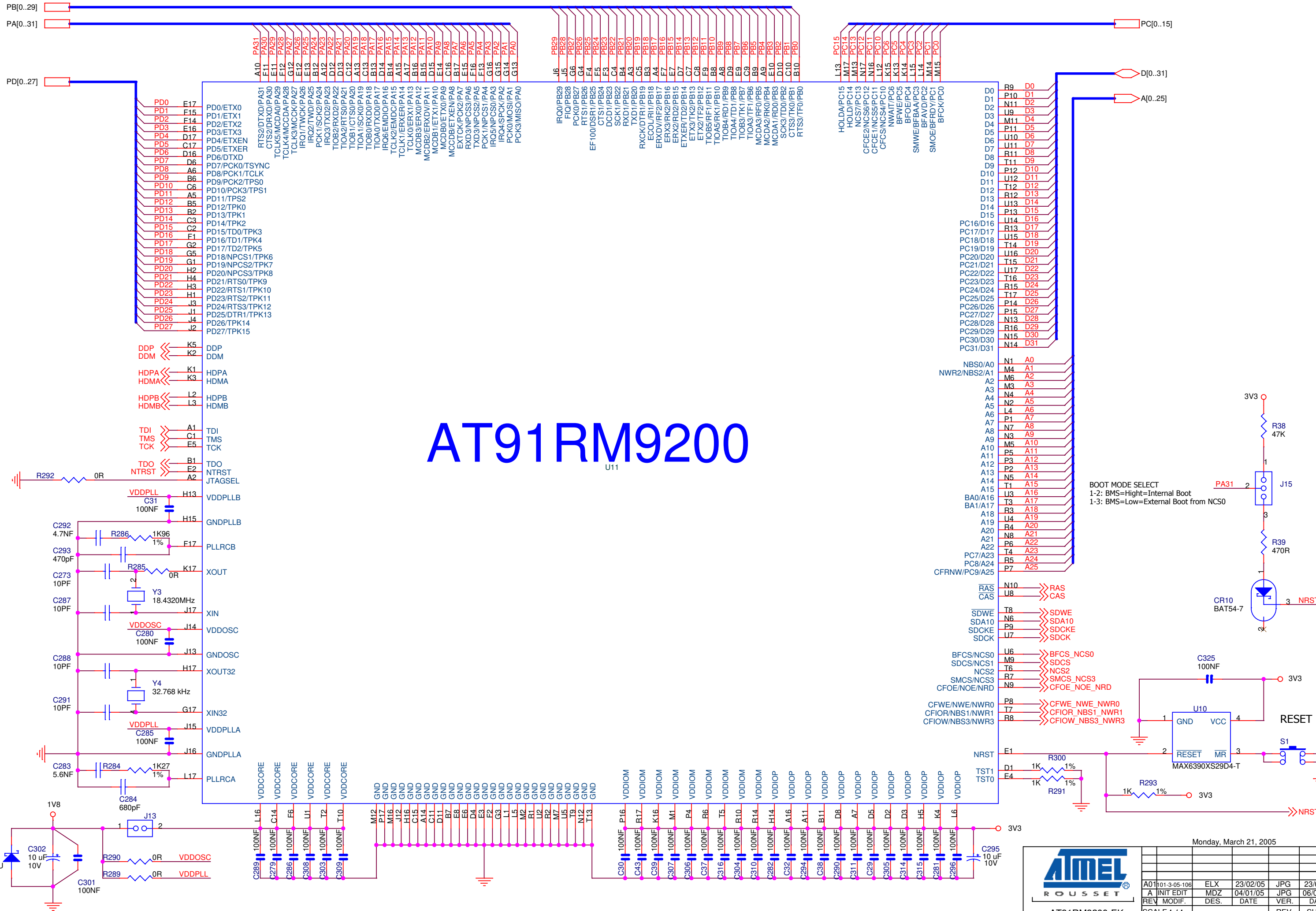

BOOT MODE SELECT
1-2: BMS=High=Internal Boot
1-3: BMS=Low=External Boot from NCS0

Monday, March 21, 2005

ATMEL ROUSSET					
A01	01-3-05-106	ELX	23/02/05	JPG	23/02/05
A	INIT EDIT	MDZ	04/01/05	JPG	06/01/05
REV	MODIF.	DES.	DATE	VER.	DATE
AT91RM9200-EK		SCALE 1/1		REV.	SHEET 2/9
AT91RM9200		63SC04226		A01	

This agreement is our property. Reproduction and publication without our written authorization shall expose offender to legal proceedings.

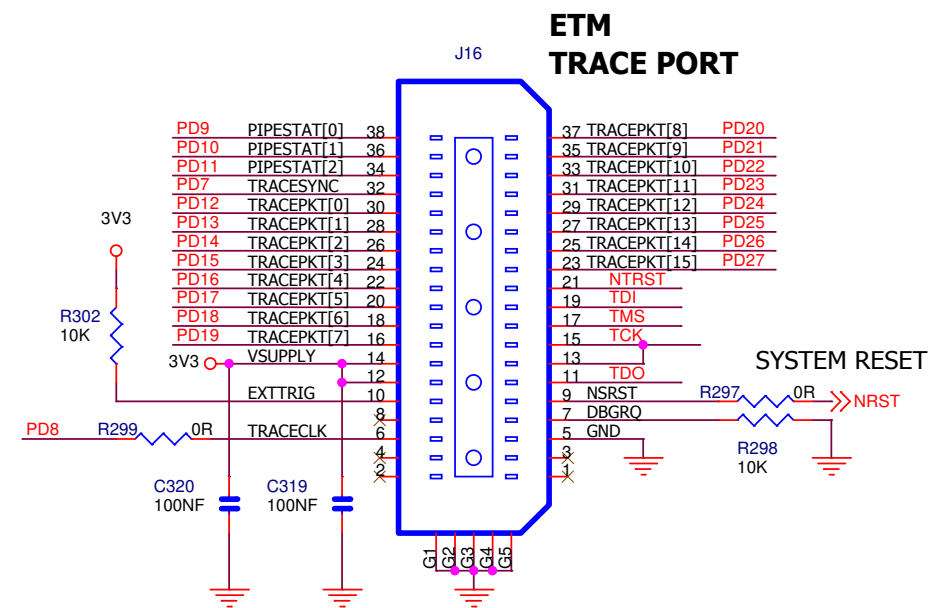
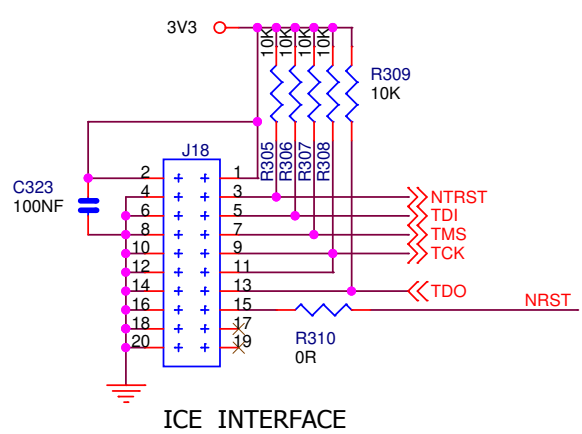
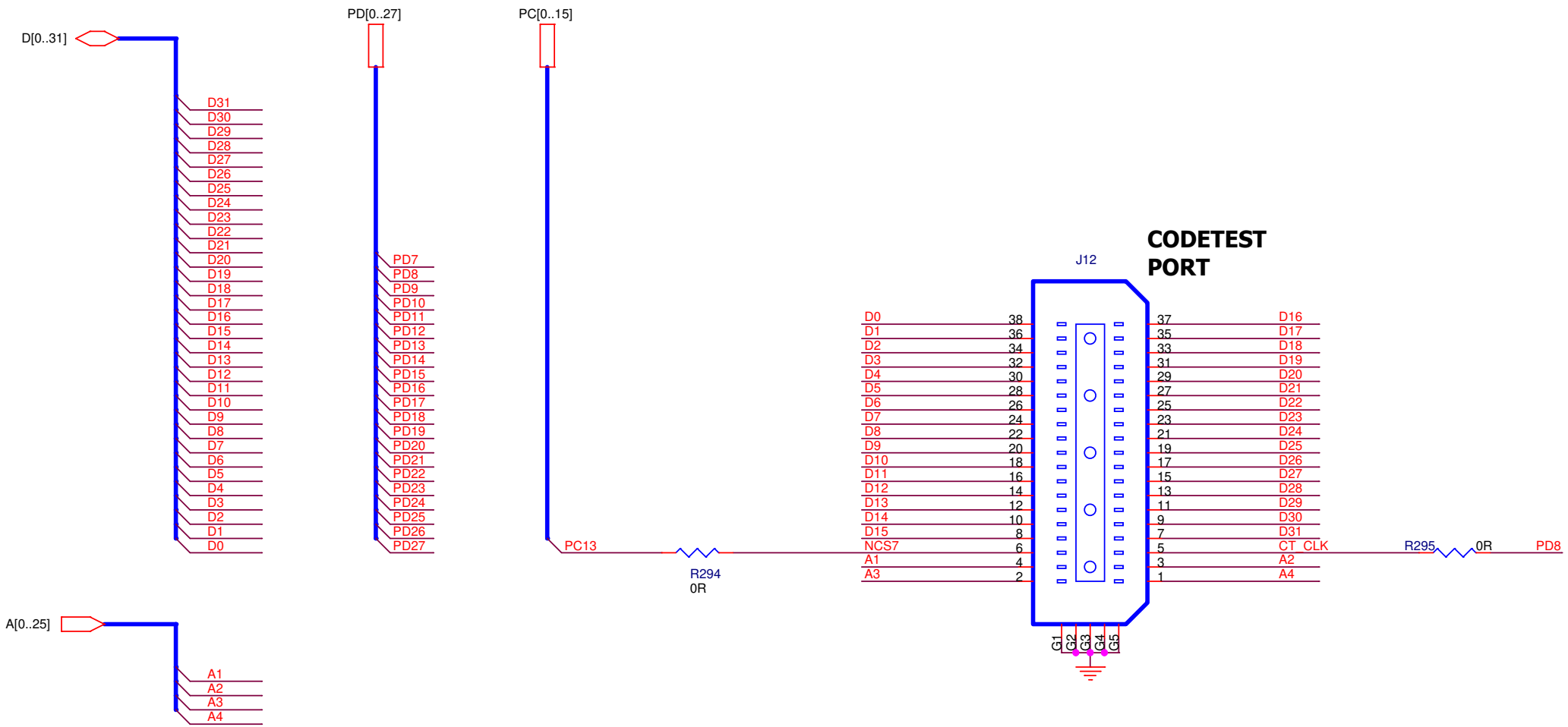

Monday, March 21, 2005

ATMEL ROUSSET		A01 01-3-05-106		ELX	23/02/05	JPG	23/02/05
AT91RM9200-EK		A INIT EDIT		MDZ	04/01/05	JPG	06/01/05
ETM - ICE - TEST		REV MODIF.		DES.	DATE	VER.	DATE
SCALE 1/1		REV. 1/1		63SC04226		A01	SHEET 3/9

This agreement is our property. Reproduction and publication without our written authorization shall expose offender to legal proceedings.

EBI SDRAM INTERFACE

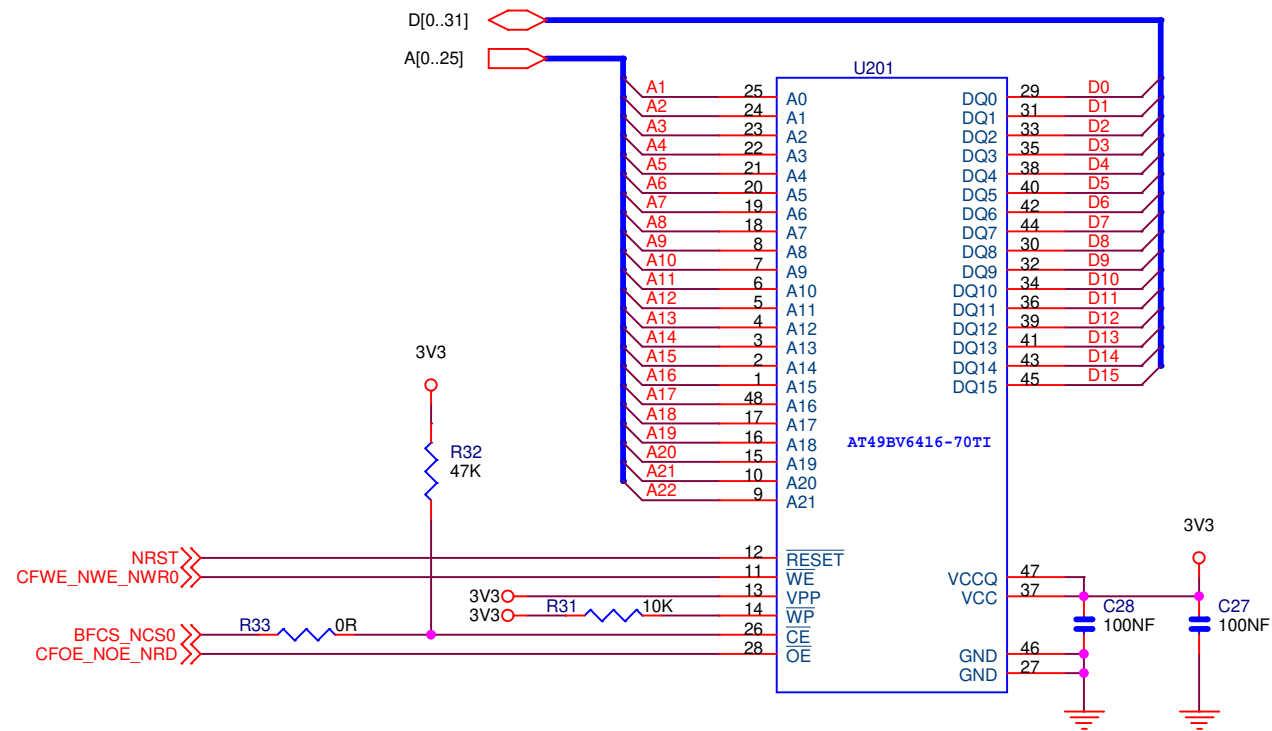
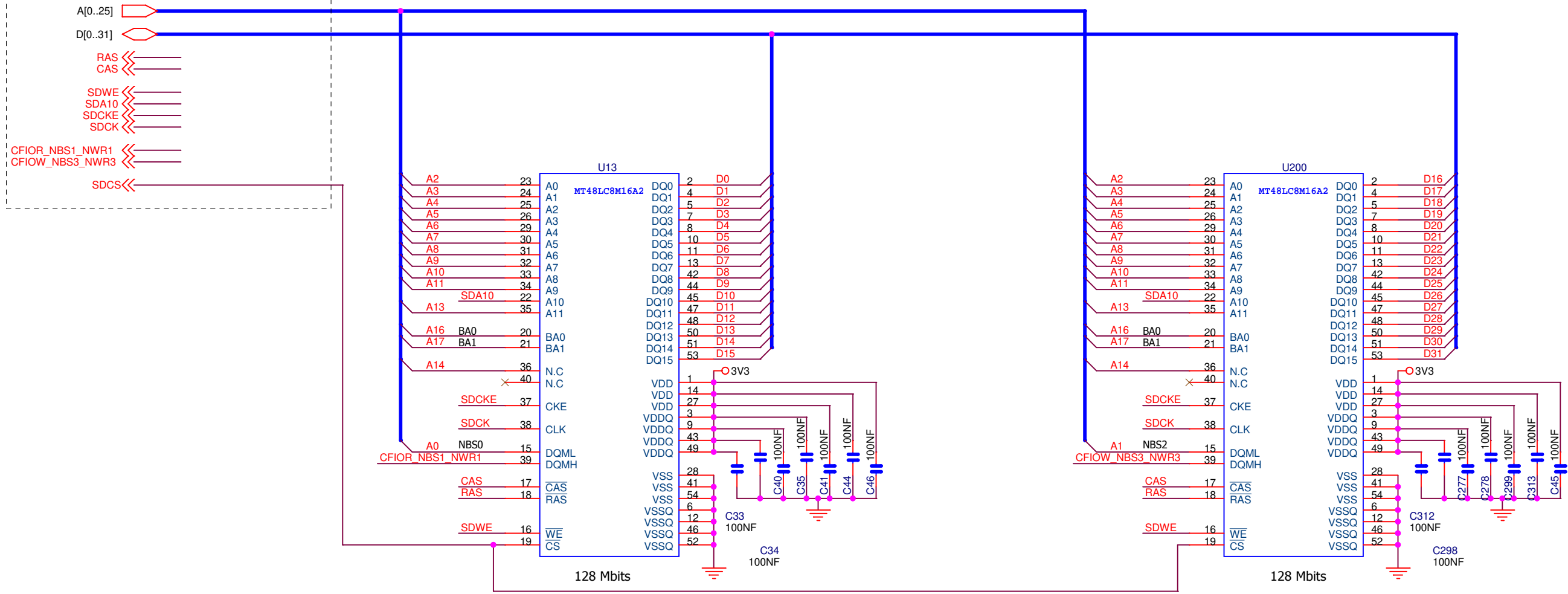

Monday, March 21, 2005

ATMEL ROUSSET					
A01	101-3-05-108	ELX	23/02/05	JPG	23/02/05
A	INIT EDIT	MDZ	04/01/05	JPG	06/01/05
REV	MODIF.	DES.	DATE	VER.	DATE
SCALE 1/1				REV.	SHEET 4/9
AT91RM9200-EK				63SC042261 A01	
SDRAM & FLASH					

This agreement is our property. Reproduction and publication without our written authorization shall expose offender to legal proceedings.

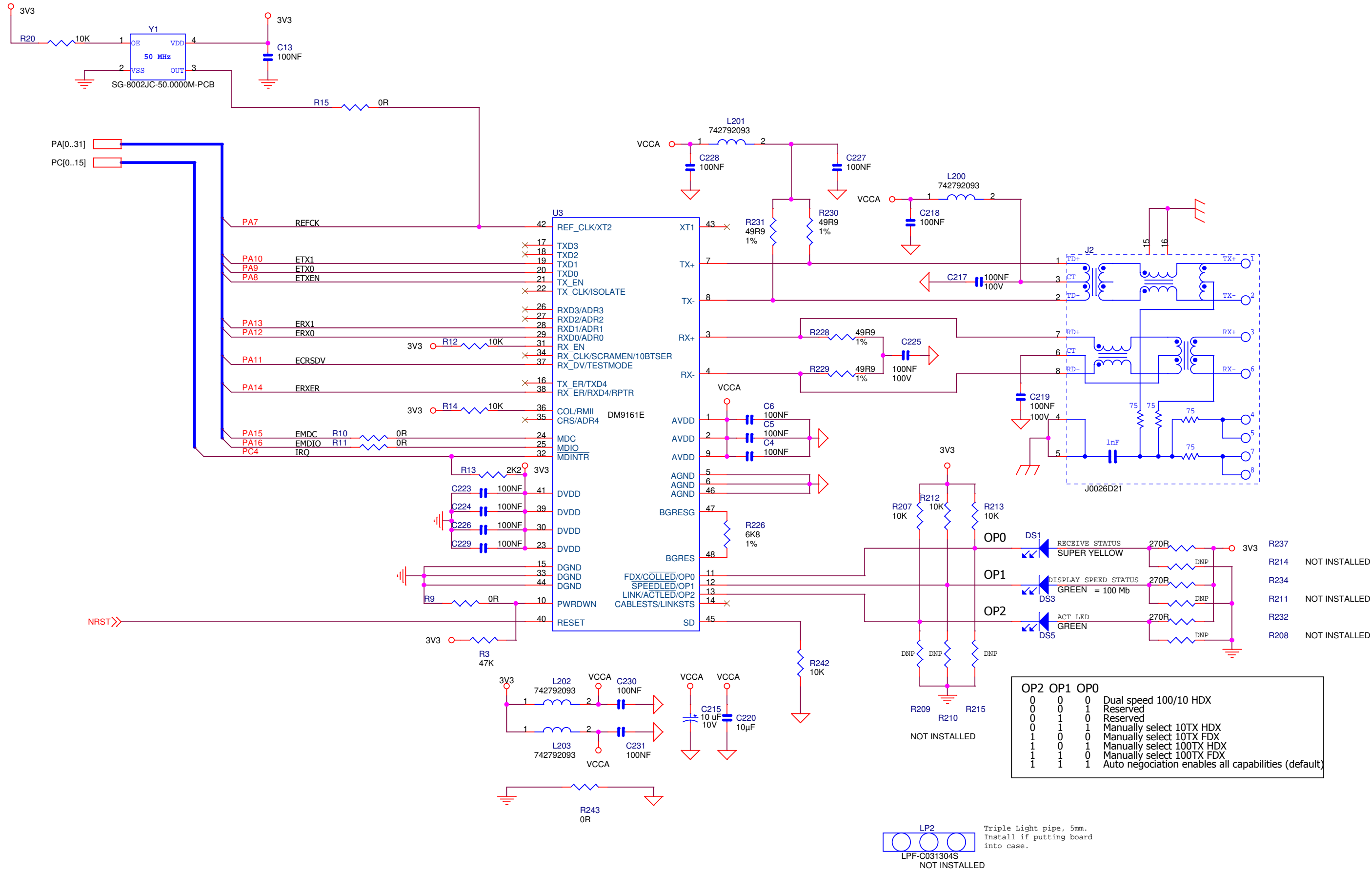

OP2	OP1	OP0	Description
0	0	0	Dual speed 100/10 HDX
0	0	1	Reserved
0	1	0	Reserved
0	1	1	Manually select 10TX HDX
1	0	0	Manually select 10TX FDX
1	0	1	Manually select 100TX HDX
1	1	0	Manually select 100TX FDX
1	1	1	Auto negotiation enables all capabilities (default)

LP2 Triple Light pipe, 5mm.
Install if putting board into case.
LPF-C031304S NOT INSTALLED

Monday, March 21, 2005

AT91RM9200-EK		SCALE 1/1	REV. SHEET		
ETHERNET		63SC04226 A01		5/9	

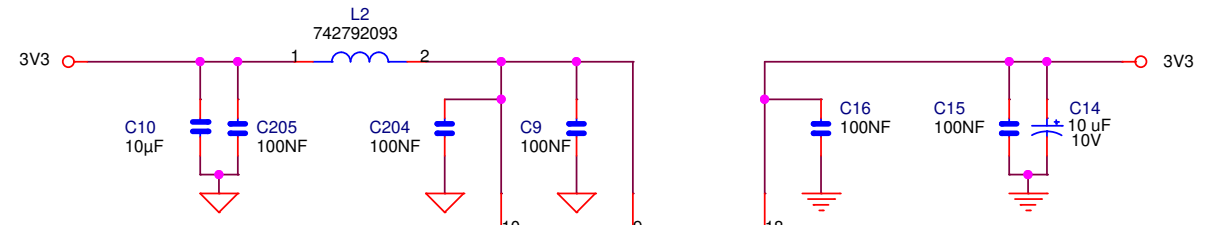

LINE OUT

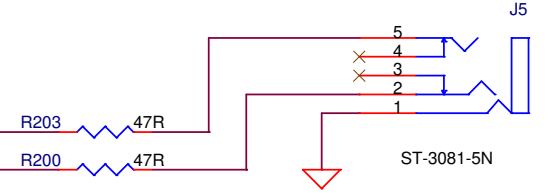

DAC3550A

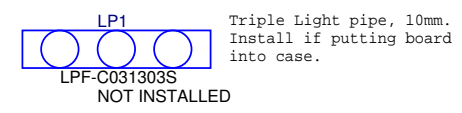
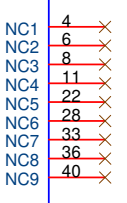
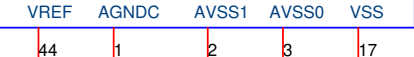
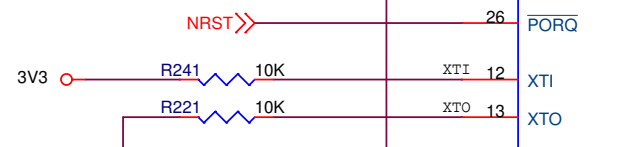
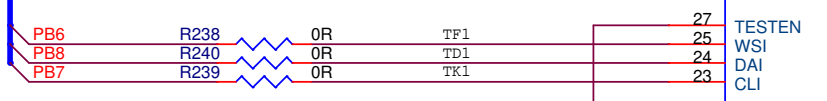
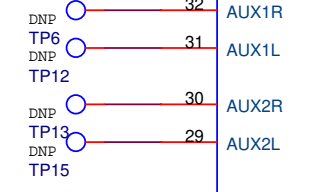
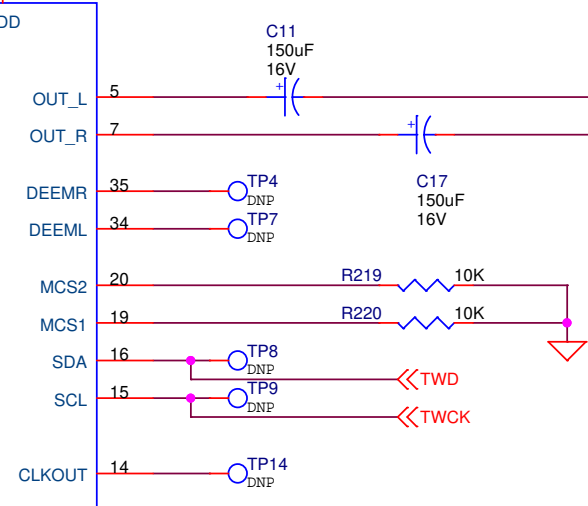
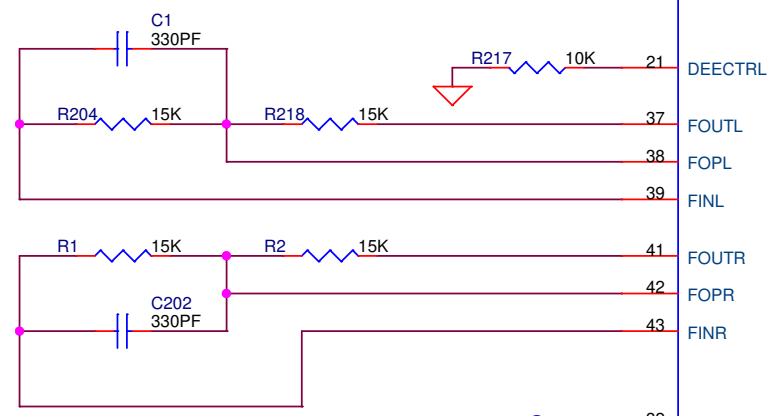

Triple Light pipe, 10mm.
Install if putting board
into case.

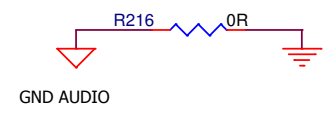
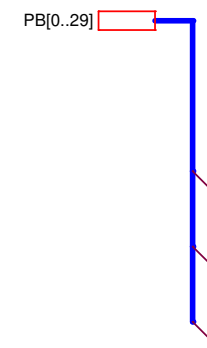
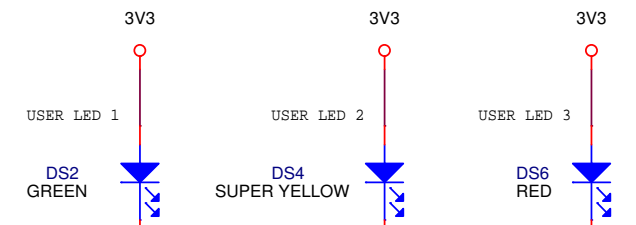

Monday, March 21, 2005

ATMEL ROUSSET		A01 101-3-05-106		ELX	23/02/05	JPG	23/02/05
AT91RM9200-EK		A INIT EDIT		MDZ	04/01/05	JPG	06/01/05
I2S STEREO DAC		REV MODIF.		DES.	DATE	VER.	DATE
SCALE 1/1		REV. SHEET		63SC042261A01		6/9	

This agreement is our property. Reproduction and publication without our written authorization shall expose offender to legal proceedings.