



Chipsmall Limited consists of a professional team with an average of over 10 year of expertise in the distribution of electronic components. Based in Hongkong, we have already established firm and mutual-benefit business relationships with customers from,Europe,America and south Asia,supplying obsolete and hard-to-find components to meet their specific needs.

With the principle of “Quality Parts,Customers Priority,Honest Operation,and Considerate Service”,our business mainly focus on the distribution of electronic components. Line cards we deal with include Microchip,ALPS,ROHM,Xilinx,Pulse,ON,Everlight and Freescale. Main products comprise IC,Modules,Potentiometer,IC Socket,Relay,Connector.Our parts cover such applications as commercial,industrial, and automotives areas.

We are looking forward to setting up business relationship with you and hope to provide you with the best service and solution. Let us make a better world for our industry!



Contact us

Tel: +86-755-8981 8866 Fax: +86-755-8427 6832

Email & Skype: info@chipsmall.com Web: www.chipsmall.com

Address: A1208, Overseas Decoration Building, #122 Zhenhua RD., Futian, Shenzhen, China



Features

- Contactless Power Supply
- Contactless Read/Write Data Transmission
- Radio Frequency f_{RF} from 100 kHz to 150 kHz
- Basic Mode or Extended Mode
- Compatible with T5557, ATA5567
- Replacement for e5551/T5551 in Most Common Operation Modes
- Configurable for ISO/IEC 11784/785 Compatibility
- Total 363 Bits EEPROM Memory: 11 Blocks (32 Bits + 1 Lock Bit)
- High Q-antenna Tolerance Due to Build in Options
- Adaptable to Different Applications: Access Control, Animal ID and Waste Management
- On-chip Trimmed Antenna Capacitor
- Pad Options
 - ATA5577M1
 - 100 μm \times 100 μm for Wire Bonding or Flip Chip
 - ATA5577M2
 - 200 μm \times 400 μm for Direct Coil Bonding

1. Description

The ATA5577 is a contactless read/write **identification IC** (IDIC[®]) for applications in the 125-kHz or 134-kHz frequency band. A single coil connected to the chip serves as the IC's power supply and bi-directional communication interface. The antenna and chip together form a transponder or tag.

The on-chip 363-bit EEPROM (11 blocks with 33 bits each) can be read and written block-wise from a base station (reader).

Data is transmitted from the IDIC (uplink) using load modulation. This is achieved by damping the RF field with a resistive load between the two terminals Coil 1 and Coil 2. The IC receives and decodes serial base station commands (downlink), which are encoded as 100% amplitude modulated (OOK) pulse-interval-encoded bit streams.

A complete datasheet with further technical data is available on request. Please contact your local sales office.



**Read/Write LF
RFID IDIC
100 to 150 kHz**

ATA5577

Summary

NOTE: This is a summary document. The complete document is available. For more information, please contact your local Atmel sales office.

4967DS-RFID-10/08



2. Compatibility

The ATA5577 is designed to be compatible with the T5557/ATA5567. The structure of the configuration register is identical. The two modes, Basic mode and Extended mode, are also available. The ATA5577 is able to replace the e5551/T5551 in most common operation modes. In all applications, the correct functionality of the replacements must be evaluated and proved.

For further details, refer to Atmel®'s web site for product-relevant application notes.

3. System Block Diagram

Figure 3-1. RFID System Using ATA5577 Tag

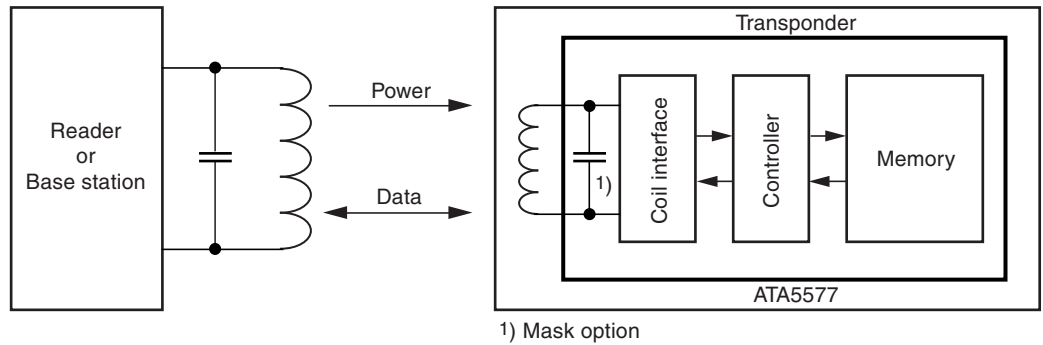

4. ATA5577 - Functional Blocks

Figure 4-1. Block Diagram

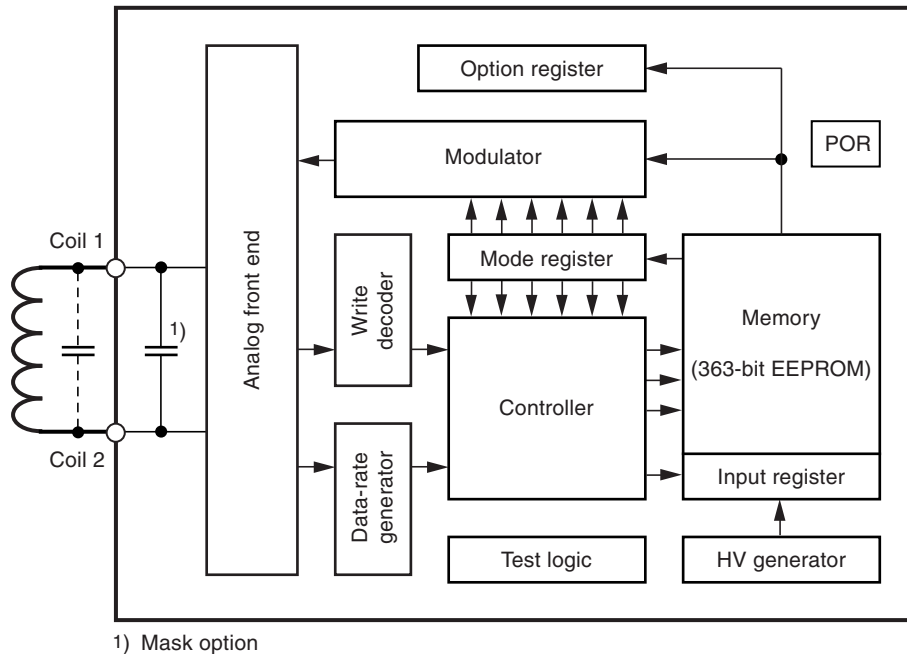

4.1 Analog Front End (AFE)

The AFE includes all circuits that are directly connected to the coil terminals. It generates the IC's power supply and handles the bi-directional data communication with the reader. It consists of the following blocks:

- Rectifier to generate a DC supply voltage from the AC coil voltage
- Clock extractor
- Switchable load between Coil 1 and Coil 2 for data transmission from the tag to the reader
- Field-gap detector for data transmission from the base station to the tag
- ESD-protection circuitry

4.2 Data-rate Generator

The data rate is binary programmable to operate at any even-numbered data rate between RF/2 and RF/128 or to any of the fixed Basic mode data rates (RF/8, RF/16, RF/32, RF/40, RF/50, RF/64, RF/100 and RF/128).

4.3 Write Decoder

The write decoder detects the write gaps and verifies the validity of the data stream according to the Atmel e555x downlink protocol (pulse interval encoding).

4.4 HV Generator

This on-chip charge pump circuit generates the high voltage required to program the EEPROM.

4.5 DC Supply

Power is externally supplied to the IDIC via the two coil connections. The IC rectifies and regulates this RF source and uses it to generate its supply voltage.

4.6 Power-On Reset (POR)

The power-on reset circuit blocks the voltage supply to the IDIC until an acceptable voltage threshold has been reached.

4.7 Clock Extraction

The clock extraction circuit uses the external RF signal as its internal clock source.

4.8 Controller

The control logic module executes the following functions:

- Load mode register with configuration data from EEPROM block 0 after power-on and during reading
- Load option register with the settings for the analog front end stored in EEPROM page 1 block 3 after power-on and during reading
- Control all EEPROM memory read/write access and data protection
- Handles the downlink command decoding detecting protocol violations and error conditions

4.9 Mode Register

The mode register maintains a readable shadow copy of the configuration data held in block 0 of the EEPROM. It is continually refreshed during read mode and (re-)loaded after every POR event or reset command. On delivery, the mode register is pre-programmed with default values (see full version of the datasheet).

4.10 Modulator

The modulator encodes the serialized EEPROM data for transmission to a tag reader or base station. Several types of modulation are available including Manchester, bi-phase, FSK, PSK, and NRZ.

4.11 Memory

Figure 4-2. Memory Map

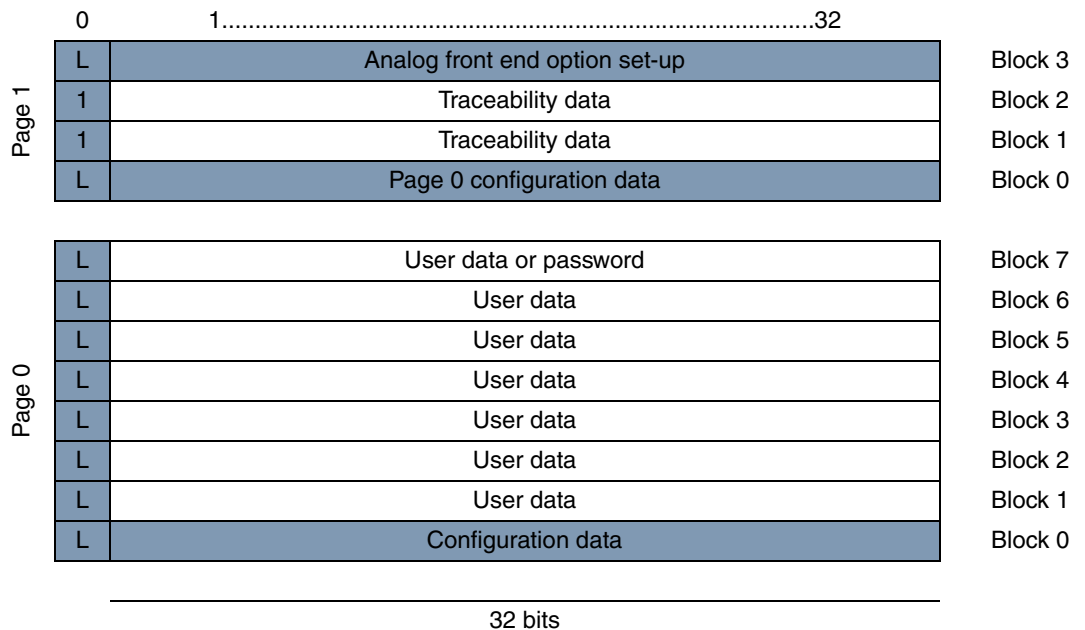

The memory is a 363-bit EEPROM, which is arranged in 11 blocks of 33 bits each. Each block includes a single *Lock* bit, which is responsible for write-protecting the associated block. Programming takes place on a block basis, so a complete block (including lock bit) can be programmed with a single command. The memory is subdivided into two page areas. Page 0 contains 8 blocks and page 1 contains 4 blocks. All 33 bits of a block, including the lock bit, are programmed simultaneously.

Block 0 of page 0 contains the mode/configuration data, which is not transmitted during regular read operations. Addressing block 0 will always affect block 0 of page 0 regardless of the page selector. Block 7 of page 0 may be used as a write-protection password.

Block 3 of page 1 contains the option register, which is not transmitted during regular-read operation.

Bit 0 of every block is the lock bit for that block. Once locked, the block (including the lock bit itself) is not re-programmable via the RF field.

Blocks 1 and 2 of page 1 contain traceability data and are transmitted with the modulation parameters defined in the configuration register after the opcode “11” is issued by the reader. The traceability data blocks are programmed and locked by Atmel.

5. Absolute Maximum Ratings

Stresses beyond those listed under “Absolute Maximum Ratings” may cause permanent damage to the device. This is a stress rating only and functional operation of the device at these or any other conditions beyond those indicated in the operational sections of this specification is not implied. Exposure to absolute maximum rating conditions for extended periods may affect device reliability.

Parameters	Symbol	Value	Unit
Maximum DC current into Coil1/Coil2	I_{coil}	20 (TBD)	mA
Maximum AC current into Coil1/Coil2, $f = 125$ kHz	$I_{\text{coil p}}$	20 (TBD)	mA
Power dissipation (die) (free-air condition, time of application: 1s)	P_{tot}	100 (TBD)	mW
Electrostatic discharge maximum to ANSI/ESD-STM5.1-2001 standard (HBM)	V_{max}	2000 (TBD)	V
Operating ambient temperature range	T_{amb}	-40 to +85	°C
Storage temperature range (data retention reduced)	T_{stg}	-40 to +150	°C

6. Electrical Characteristics

$T_{amb} = +25^{\circ}\text{C}$; $f_{coil} = 125\text{ kHz}$; unless otherwise specified

No.	Parameters	Test Conditions	Symbol	Min.	Typ.	Max.	Unit	Type*
1	RF frequency range		f_{RF}	100	125	150	kHz	
2.1	Supply current (without current consumed by the external LC tank circuit)	$T_{amb} = 25^{\circ}\text{C}^{(1)}$	I_{DD}		1.5	TBD	μA	T
2.2		Read - full temperature range			2	TBD	μA	Q
2.3		Programming - full temperature range			25	TBD	μA	Q
3.1	Coil voltage (AC supply)	POR threshold (50-mV hysteresis)	$V_{coil\ pp}$	TBD	3.6	TBD	V	Q
3.2		Read mode and write command ⁽²⁾		6		V_{clamp}	V	Q
3.3		Program EEPROM ⁽²⁾		8		V_{clamp}	V	Q
4	Start-up time	$V_{coil\ pp} = 6\text{V}$	$t_{startup}$		2.5	TBD	ms	Q
5.1	Clamp voltage (depends on settings in option register)	3-mA current into Coil1/Coil2	$V_{pp\ clamp\ lo}$	TBD	11	TBD	V	Q
5.2			$V_{pp\ clamp\ med}$	TBD	13	TBD	V	Q
5.3			$V_{pp\ clamp\ hi}$	TBD	17	TBD	V	T
5.4		20-mA current into Coil1/Coil2	$V_{pp\ clamp\ med}$	TBD	15	TBD	V	T
6.1	Modulation parameters (depends on settings in option register)	3-mA current into Coil1/Coil2 and modulation ON	$V_{pp\ mod\ lo}$	TBD	3	TBD	V	T
6.2			$V_{pp\ mod\ med}$	TBD	5	TBD	V	Q
6.3			$V_{pp\ mod\ hi}$	TBD	7	TBD	V	Q
6.4		20 mA current into Coil1/Coil2 and modulation ON	$V_{pp\ mod\ med}$	TBD	7.5	TBD	V	T
6.5	Thermal stability		$V_{mod\ lo}/T_{amb}$		-1		mV/ $^{\circ}\text{C}$	Q
7.1	Clock detection level (depends on settings in option register)	$V_{coil\ pp} = 8\text{V}$	$V_{clkdet\ lo}$	TBD	250	TBD	mV	Q
7.2			$V_{clkdet\ med}$	TBD	550	TBD	mV	T
7.3			$V_{clkdet\ hi}$	TBD	800	TBD	mV	Q
7.4	Gap detection level (depends on settings in option register)	$V_{coil\ pp} = 8\text{V}$	$V_{gapdet\ lo}$	TBD	250	TBD	mV	Q
7.5			$V_{gapdet\ med}$	TBD	550	TBD	mV	T
7.6			$V_{gapdet\ hi}$	TBD	850	TBD	mV	Q
8	Programming time	From last command gap to re-enter read mode (64 + 648 internal clocks)	T_{prog}	5	5.7	6	ms	T
9	Endurance	Erase all/Write all ⁽³⁾	n_{cycle}	100000			Cycles	Q

*) Type means: T: directly or indirectly tested during production; Q: guaranteed based on initial product qualification data

Notes: 1. I_{DD} measurement set-up $R = 100\text{k}\Omega$; $V_{CLK} = V_{coil} = 3\text{V}$; EEPROM programmed to 00 ... 000 (erase all); chip in modulation defeat. $I_{DD} = (V_{OUTmax} - V_{CLK}) / R$

2. Current into Coil1/Coil2 is limited to 10 mA.

3. Since EEPROM performance is influenced by assembly processes, Atmel confirms the parameters for DOW (tested die on uncut wafer) delivery.

6. Electrical Characteristics (Continued)

$T_{amb} = +25^{\circ}\text{C}$; $f_{coil} = 125\text{ kHz}$; unless otherwise specified

No.	Parameters	Test Conditions	Symbol	Min.	Typ.	Max.	Unit	Type*
10.1	Data retention	Top = 55°C ⁽³⁾	$t_{retention}$	10	20	50	Years	Q
10.2		Top = 150°C ⁽³⁾	$t_{retention}$	96			hrs	T
10.3		Top = 250°C ⁽³⁾	$t_{retention}$	24			hrs	Q
11.1	Resonance capacitor	Mask option $V_{coil\ pp} = 1\text{ V}$	C_r	320	330	340	pF	T
11.2				242	250	258		
11.3				TBD	130	TBD		
11.4				TBD	75	TBD		
11.5				TBD	10	TBD	Q	
12.1	Micromodule capacitor parameters	Capacitance tolerance T_{amb}	C_r	320	330	340	pF	T
12.2		Temperature coefficient	TBD	TBD	TBD	TBD	TBD	TBD

*) Type means: T: directly or indirectly tested during production; Q: guaranteed based on initial product qualification data

Notes: 1. I_{DD} measurement set-up $R = 100\text{ k}\Omega$; $V_{CLK} = V_{coil} = 3\text{ V}$; EEPROM programmed to 00 ... 000 (erase all); chip in modulation defeat. $I_{DD} = (V_{OUTmax} - V_{CLK}) / R$

2. Current into Coil1/Coil2 is limited to 10 mA.

3. Since EEPROM performance is influenced by assembly processes, Atmel confirms the parameters for DOW (tested die on uncut wafer) delivery.

7. Revision History

Please note that the following page numbers referred to in this section refer to the specific revision mentioned, not to this document.

Revision No.	History
4967DS-RFID-10/08	<ul style="list-style-type: none"> Features on page 1 changed
4967CS-RFID-01/08	<ul style="list-style-type: none"> Features on page 1 changed Section 2 "Compatibility" on page 2 changed Section 4.9 "Mode Register" on page 4 changed
4967BS-RFID-09/07	<ul style="list-style-type: none"> Put datasheet in a new template Section 4.2 "Data-rate Generator" on page 3 changed Figure 4-2 "Memory Map" on page 5 changed Section 6 "Electrical Characteristics" numbers 2.1, 2.2 and 2.3 on page 6 changed



Headquarters

Atmel Corporation
2325 Orchard Parkway
San Jose, CA 95131
USA
Tel: 1(408) 441-0311
Fax: 1(408) 487-2600

International

Atmel Asia
Room 1219
Chinachem Golden Plaza
77 Mody Road Tsimshatsui
East Kowloon
Hong Kong
Tel: (852) 2721-9778
Fax: (852) 2722-1369

Atmel Europe
Le Krebs
8, Rue Jean-Pierre Timbaud
BP 309
78054
Saint-Quentin-en-Yvelines Cedex
France
Tel: (33) 1-30-60-70-00
Fax: (33) 1-30-60-71-11

Atmel Japan
9F, Tonetsu Shinkawa Bldg.
1-24-8 Shinkawa
Chuo-ku, Tokyo 104-0033
Japan
Tel: (81) 3-3523-3551
Fax: (81) 3-3523-7581

Product Contact

Web Site
www.atmel.com

Technical Support
rfid@atmel.com

Sales Contact
www.atmel.com/contacts

Literature Requests
www.atmel.com/literature

Disclaimer: The information in this document is provided in connection with Atmel products. No license, express or implied, by estoppel or otherwise, to any intellectual property right is granted by this document or in connection with the sale of Atmel products. **EXCEPT AS SET FORTH IN ATMEL'S TERMS AND CONDITIONS OF SALE LOCATED ON ATMEL'S WEB SITE, ATMEL ASSUMES NO LIABILITY WHATSOEVER AND DISCLAIMS ANY EXPRESS, IMPLIED OR STATUTORY WARRANTY RELATING TO ITS PRODUCTS INCLUDING, BUT NOT LIMITED TO, THE IMPLIED WARRANTY OF MERCHANTABILITY, FITNESS FOR A PARTICULAR PURPOSE, OR NON-INFRINGEMENT. IN NO EVENT SHALL ATMEL BE LIABLE FOR ANY DIRECT, INDIRECT, CONSEQUENTIAL, PUNITIVE, SPECIAL OR INCIDENTAL DAMAGES (INCLUDING, WITHOUT LIMITATION, DAMAGES FOR LOSS OF PROFITS, BUSINESS INTERRUPTION, OR LOSS OF INFORMATION) ARISING OUT OF THE USE OR INABILITY TO USE THIS DOCUMENT, EVEN IF ATMEL HAS BEEN ADVISED OF THE POSSIBILITY OF SUCH DAMAGES.** Atmel makes no representations or warranties with respect to the accuracy or completeness of the contents of this document and reserves the right to make changes to specifications and product descriptions at any time without notice. Atmel does not make any commitment to update the information contained herein. Unless specifically provided otherwise, Atmel products are not suitable for, and shall not be used in, automotive applications. Atmel's products are not intended, authorized, or warranted for use as components in applications intended to support or sustain life.

© 2008 Atmel Corporation. All rights reserved. Atmel®, logo and combinations thereof, IDIC® and others are registered trademarks or trademarks of Atmel Corporation or its subsidiaries. Other terms and product names may be trademarks of others.