



Chipsmall Limited consists of a professional team with an average of over 10 year of expertise in the distribution of electronic components. Based in Hongkong, we have already established firm and mutual-benefit business relationships with customers from,Europe,America and south Asia,supplying obsolete and hard-to-find components to meet their specific needs.

With the principle of “Quality Parts,Customers Priority,Honest Operation,and Considerate Service”,our business mainly focus on the distribution of electronic components. Line cards we deal with include Microchip,ALPS,ROHM,Xilinx,Pulse,ON,Everlight and Freescale. Main products comprise IC,Modules,Potentiometer,IC Socket,Relay,Connector.Our parts cover such applications as commercial,industrial, and automotives areas.

We are looking forward to setting up business relationship with you and hope to provide you with the best service and solution. Let us make a better world for our industry!



## Contact us

Tel: +86-755-8981 8866 Fax: +86-755-8427 6832

Email & Skype: info@chipsmall.com Web: www.chipsmall.com

Address: A1208, Overseas Decoration Building, #122 Zhenhua RD., Futian, Shenzhen, China



## Features

- High FSK sensitivity:  $-105.5\text{dBm}$  at 20Kbit/s/ $-109\text{dBm}$  at 2.4Kbit/s (433.92MHz)
- High ASK sensitivity:  $-111.5\text{dBm}$  at 10Kbit/s/ $-116\text{dBm}$  at 2.4Kbit/s (100% ASK, carrier level 433.92MHz)
- Low supply current: 10.5mA in RX and TX mode (3V/TX with 5dBm/433.92MHz)
- Data rate 1 to 20Kbit/s Manchester FSK, 1 to 10Kbit/s Manchester ASK
- ASK/FSK receiver uses a low IF architecture with high selectivity, blocking and low intermodulation (typical 3dB blocking 55.5dBC at  $\pm 750\text{kHz}$ /60.5dBC at  $\pm 1.5\text{MHz}$  and 67dBC at  $\pm 10\text{MHz}$ , system I1dBCP =  $-30\text{dBm}$ /system IIP3 =  $-20\text{dBm}$ )
- Wide bandwidth AGC to handle large outband blockers above the system I1dBCP
- 226kHz IF (intermediate frequency) with 30dB image rejection and 220kHz system bandwidth to support TPM transmitters using Atmel® ATA5756/ATA5757 transmitters with standard crystals
- Transmitter uses closed loop FSK modulation with fractional-N synthesizer with high PLL bandwidth and an excellent isolation between PLL and PA
- Tolerances of XTAL compensated by fractional-N synthesizer with 800Hz RF resolution
- Integrated RX/TX-switch, single-ended RF input and output
- RSSI (received signal strength indicator)
- Communication to microcontroller with SPI interface working at 500kBit/s maximum
- Configurable self polling and RX/TX protocol handling with FIFO-RAM buffering of received and transmitted data
- 1 push button input and 1 wake-up input are active in power-down mode
- Integrated XTAL capacitors
- PA efficiency: up to 38% (433.92MHz/10dBm/3V)
- Low In-band sensitivity change of typically  $\pm 2.0\text{dB}$  within  $\pm 75\text{kHz}$  center frequency change in the complete temperature and supply voltage range

- Fully integrated PLL with low phase noise VCO, PLL loop filter and full support of multi-channel operation with arbitrary channel distance due to fractional-N synthesizer
- Sophisticated threshold control and quasi-peak detector circuit in the data slicer
- 433.92MHz, and 315MHz without external VCO and PLL components
- Efficient XTO start-up circuit ( $> -1.5k\Omega$  worst case start impedance)
- Changing of modulation type ASK/FSK and data rate without component changes to allow different modulation schemes in TPM and RKE
- Minimal external circuitry requirements for complete system solution
- Adjustable output power: 0 to 10dBm adjusted and stabilized with external resistor, programmable output power with 0.5dB steps with internal resistor
- Clock and interrupt generation for microcontroller
- ESD protection at all pins ( $\pm 2.5kV$  HBM,  $\pm 200V$  MM,  $\pm 500V$  FCDM)
- Supply voltage range: 2.15V to 3.6V or 4.4V to 5.25V
- Typical power-down current  $< 10nA$
- Temperature range:  $-40^{\circ}C$  to  $+105^{\circ}C$
- Small 7mm  $\times$  7mm QFN48 package

## Applications

---

- Automotive keyless entry and passive entry go (handsfree car access)
- Tire pressure monitoring systems
- Remote control systems
- Alarm and telemetering systems
- Energy metering
- Home automation

## Benefits

---

- No SAW device needed in key fob designs to meet automotive specifications
- Low system cost due to very high system integration level
- Only one crystal needed in system
- Less demanding specification for the microcontroller due to handling of power-down mode, delivering of clock and complete handling of receive/transmit protocol and polling
- Single-ended design with high isolation of PLL/VCO from PA and the power supply allows a loop antenna in the key fob to surround the whole application
- Integration of tire pressure monitoring, passive entry and remote keyless entry

# 1. General Description

The Atmel® ATA5823/ATA5824 is a highly integrated UHF ASK/FSK multi-channel half-duplex transceiver with low power consumption supplied in a small 7mm × 7mm QFN48 package. The receive part is built as a fully integrated low-IF receiver, whereas direct PLL modulation with the fractional-N synthesizer is used for FSK transmission and switching of the power amplifier for ASK transmission.

The device supports data rates of 1Kbit/s to 20Kbit/s (FSK) and 1Kbit/s to 10Kbit/s (ASK) in Manchester, Bi-phase and other codes in transparent mode. The Atmel ATA5824 can be used in the 433MHz to 435MHz band and the Atmel ATA5823 in the 313MHz to 316MHz band. The very high system integration level results in few numbers of external components needed.

Due to its blocking and selectivity performance, together with a typical narrow-band key-fob loop antenna with 15dB to 20dB loss, a bulky blocking SAW is not needed in the key fob application. Additionally, the building blocks needed for a typical RKE and access control system on both sides, the base and the mobile stations, are fully integrated.

Its digital control logic with self polling and protocol generation provides a fast challenge response system without using a high-performance microcontroller. Therefore, the Atmel ATA5823/ATA5824 contains a FIFO buffer RAM and can compose and receive the physical messages themselves. This provides more time for the microcontroller to carry out other functions such as calculating crypto algorithms, composing the logical messages and controlling other devices. Due to that, a standard 4-/8-bit microcontroller without special periphery and clocked with the delivered CLK output of about 4.5MHz is sufficient to control the communication link. This is especially valid for passive entry go and access control systems, where within less than 100 ms several communication responses with arbitration of the communication partner have to be handled. It is hence possible to design bi-directional RKE and passive entry go systems with a fast challenge response crypto function and prevention against relay attacks.

Figure 1-1. System Block Diagram

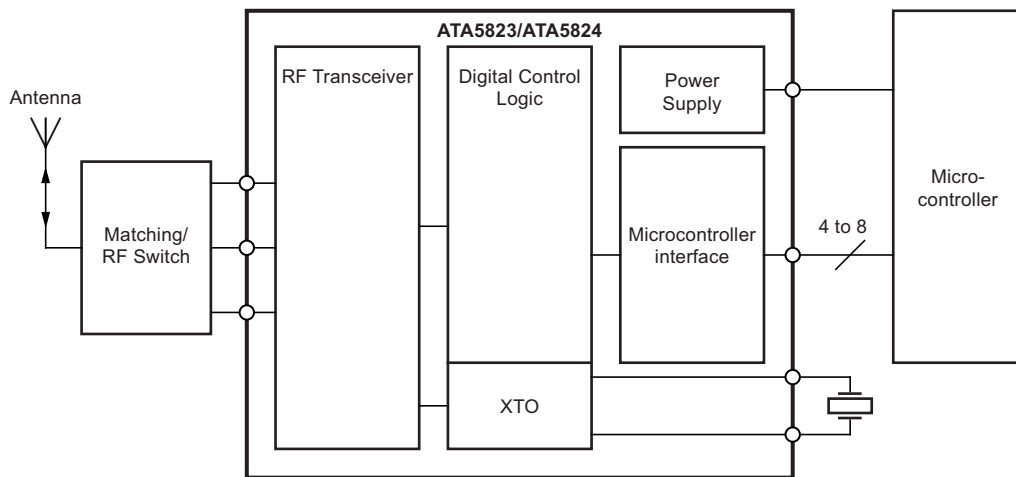

## 2. Pin Configuration

Figure 2-1. Pinning QFN48

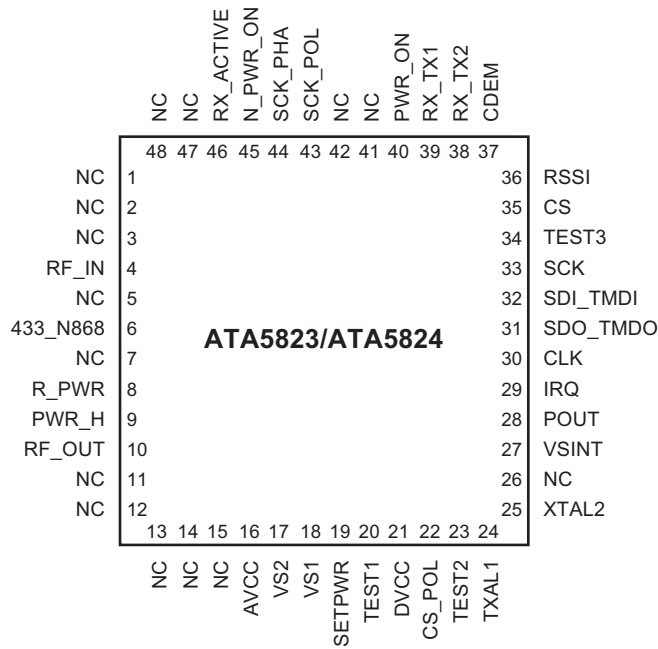

Table 2-1. Pin Description

Pin	Symbol	Function
1	NC	Not connected
2	NC	Not connected
3	NC	Not connected
4	RF_IN	RF input
5	NC	Not connected
6	433_N868	Selects RF input/output frequency range
7	NC	Not connected
8	R_PWR	Resistor to adjust output power
9	PWR_H	Pin to select output power
10	RF_OUT	RF output
11	NC	Not connected
12	NC	Not connected
13	NC	Not connected
14	NC	Not connected
15	NC	Not connected
16	AVCC	Blocking of the analog voltage supply
17	VS2	Power supply input for voltage range 4.4V to 5.6V
18	VS1	Power supply input for voltage range 2.15V to 3.6V
19	SETPWR	Internal Programmable Resistor to adjust output power
20	TEST1	Test input, at GND during operation
21	DVCC	Blocking of the digital voltage supply

**Table 2-1. Pin Description (Continued)**

Pin	Symbol	Function
22	CS_POL	Select polarity of pin CS
23	TEST2	Test input, at GND during operation
24	XTAL1	Reference crystal
25	XTAL2	Reference crystal
26	NC	Not connected
27	VSINT	Microcontroller interface supply voltage
28	POUT	Programmable output
29	IRQ	Interrupt request
30	CLK	Clock output to connect a microcontroller
31	SDO_TMDO	Serial data out/transparent mode data out
32	SDI_TMDI	Serial data in/transparent mode data in
33	SCK	Serial clock
34	TEST3	Test output open during operation
35	CS	Chip select for serial interface
36	RSSI	Output of the RSSI amplifier
37	CDEM	Capacitor to adjust the lower cut-off frequency data filter
38	RX_TX2	Has to be connected GND
39	RX_TX1	Switch pin to decouple LNA in TX mode (RKE mode)
40	PWR_ON	Input to switch on the system (active high)
41	NC	Not connected
42	NC	Not connected
43	SCK_POL	Polarity of the serial clock
44	SCK_PHA	Phase of the serial clock
45	N_PWR_ON	Keyboard input (can also be used to switch on the system, active low)
46	RX_ACTIVE	Indicates RX operation mode
47	NC	Not connected
48	NC	Not connected
	GND	Ground/Backplane (exposed die pad)

Figure 2-2. Block Diagram

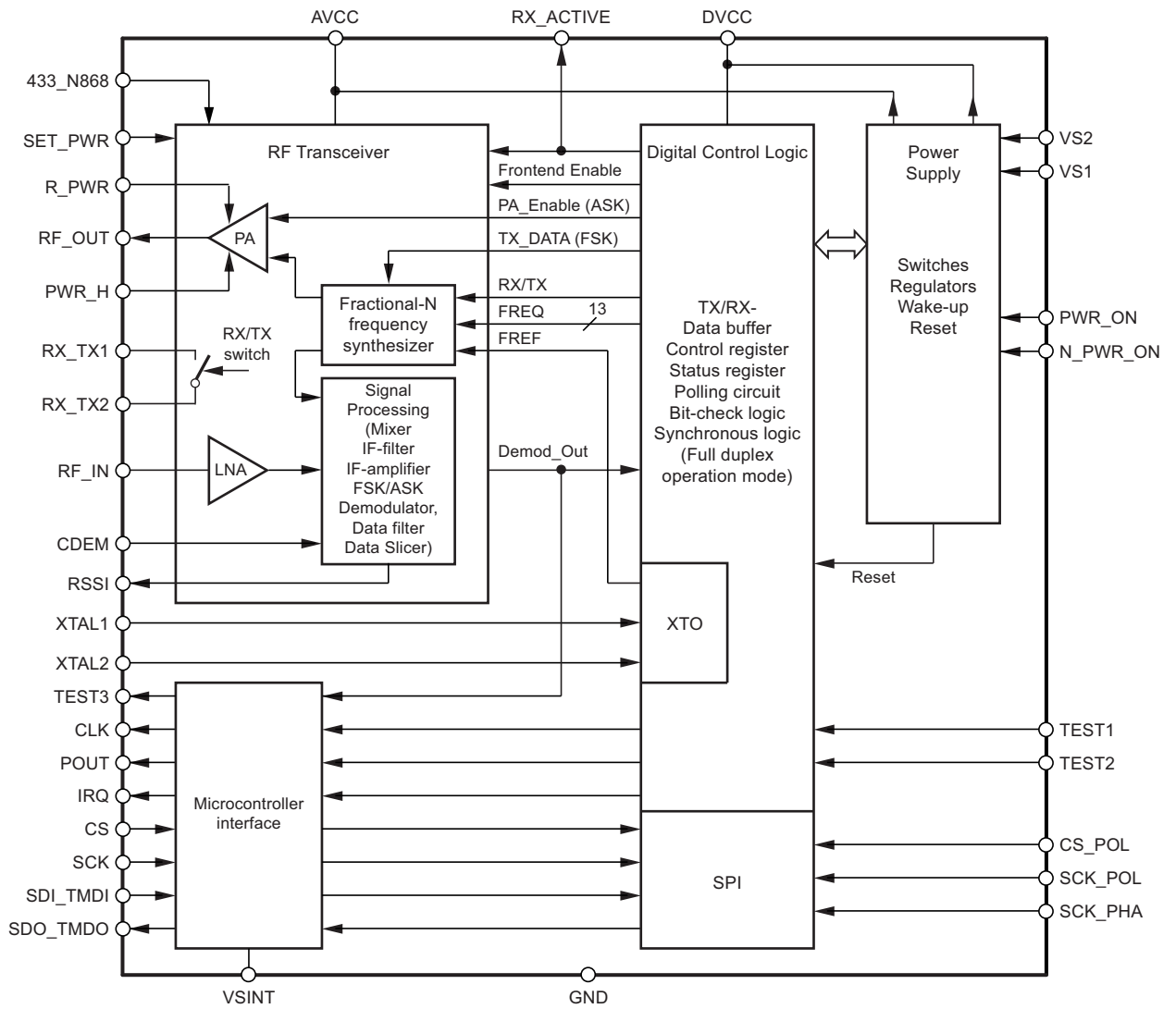

### 3. Typical Key Fob Application for Bi-directional RKE

Figure 3-1. Typical Key Fob Application for Bi-directional RKE with 5dBm TX Power, 433.92MHz

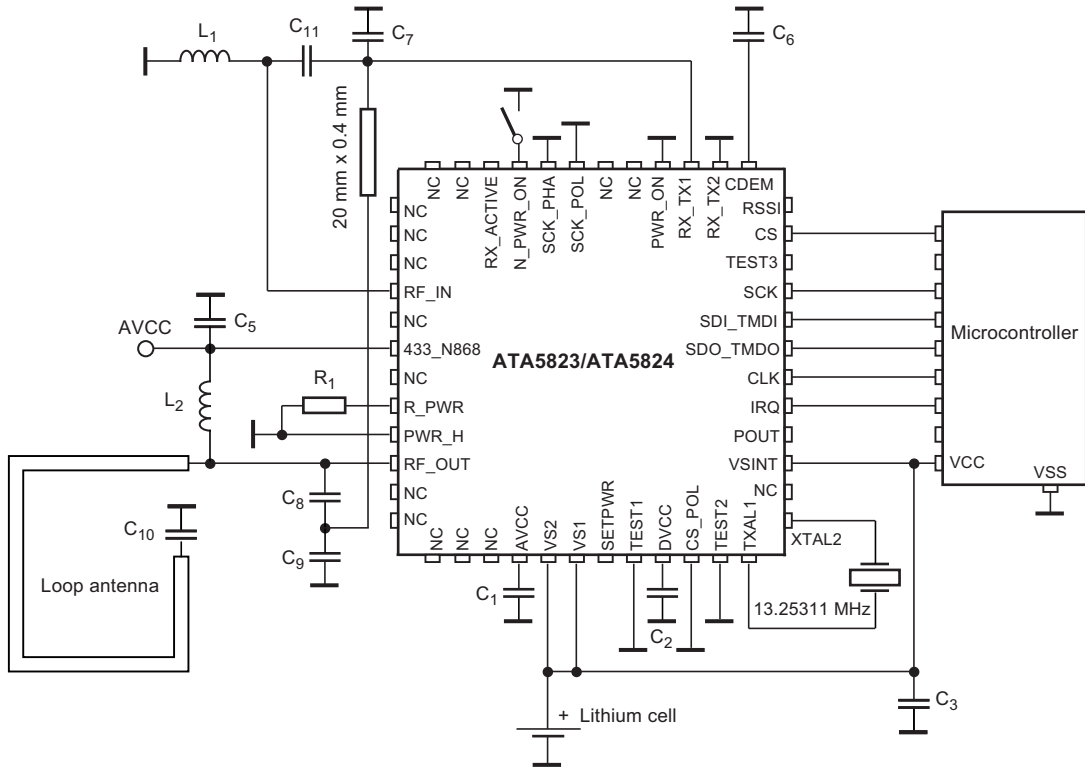

Figure 3-1 shows a typical 433.92MHz RKE key fob application. The external components are 10 capacitors, 1 resistor, 2 inductors and a crystal.  $C_1$  to  $C_3$  are 68nF voltage supply blocking capacitors.  $C_5$  is a 10nF supply blocking capacitor.  $C_6$  is a 15nF fixed capacitor used for the internal quasi-peak detector and for the high-pass frequency of the data filter.  $C_7$  to  $C_{11}$  are RF matching capacitors in the range of 1pF to 33pF.  $L_1$  is a matching inductor of about 5.6nH to 56nH.  $L_2$  is a feed inductor of about 120nH. A load capacitor of 9pF for the crystal is integrated.  $R_1$  is typically 22k $\Omega$  and sets the output power to about 5.5dBm. The loop antenna's quality factor is somewhat reduced by this application due to the quality factor of  $L_2$  and the RX/TX switch. On the other hand, this lower quality factor is necessary to have a robust design with a bandwidth that is wide enough for production tolerances. Due to the single-ended and ground-referenced design, the loop antenna can be a free-form wire around the application as it is usually employed in RKE unidirectional systems. The Atmel<sup>®</sup> ATA5823/ATA5824 provides sufficient isolation and robust pulling behavior of internal circuits from the supply voltage as well as an integrated VCO inductor to allow this. Since the efficiency of a loop antenna is proportional to the square of the surrounded area, it is beneficial to have a large loop around the application board with a lower quality factor to relax the tolerance specification of the RF matching components and to get a high antenna efficiency in spite of their lower quality factor.



## 4. Typical Car Application for Bi-directional RKE

Figure 4-1. Typical Car Application for Bi-directional RKE with 10dBm TX Power, 433.92MHz

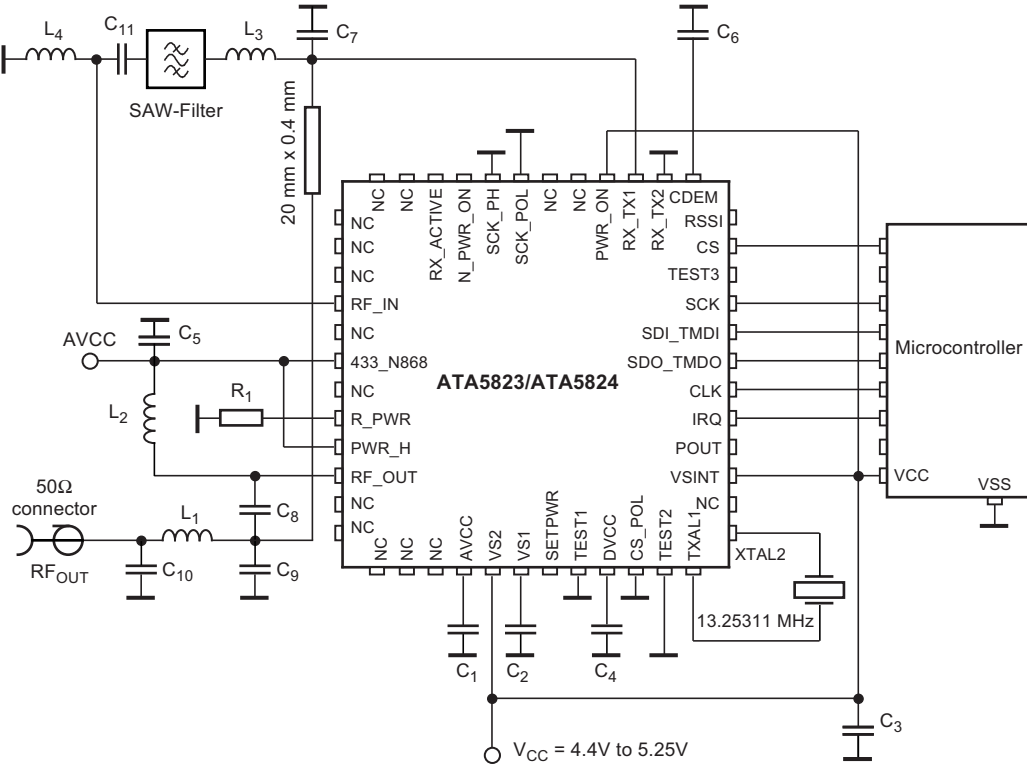

Figure 4-1 shows a typical 433.92MHz  $V_{CC} = 4.4V$  to  $5.25V$  RKE car application. The external components are 11 capacitors, 1 resistor, 4 inductors, a SAW filter and a crystal.  $C_1$ ,  $C_3$  and  $C_4$  are 68nF voltage supply blocking capacitors.  $C_2$  is a 2.2 $\mu$ F supply blocking capacitor for the internal voltage regulator.  $C_5$  is a 10nF supply blocking capacitor.  $C_6$  is a 15nF fixed capacitor used for the internal quasi-peak detector and for the high-pass frequency of the data filter.  $C_7$  to  $C_{11}$  are RF matching capacitors in the range of 1pF to 33pF.  $L_2$  to  $L_4$  are matching inductors of about 5.6nH to 56nH. A load capacitor for the crystal of 9pF is integrated.  $R_1$  is typically 22k $\Omega$  and sets the output power at  $RF_{OUT}$  to about 10dBm. Since a quarter wave or PCB antenna, which has high efficiency and wideband operation, is typically used here, it is recommended to use a SAW filter to achieve high sensitivity in case of powerful out-of-band blockers.  $L_1$ ,  $C_{10}$  and  $C_9$  together form a low-pass filter, which is needed to filter out the harmonics in the transmitted signal to meet regulations.

## 5. RF Transceiver in Half-duplex Mode

According to [Figure 2-2 on page 6](#), the RF transceiver consists of an LNA (Low-Noise Amplifier), PA (Power Amplifier), RX/TX switch, fractional-N frequency synthesizer and the signal processing part with mixer, IF filter, IF amplifier with analog RSSI, FSK/ASK demodulator, data filter and data slicer.

In receive mode the LNA pre-amplifies the received signal which is converted down to 226kHz intermediate frequency (IF), filtered and amplified before it is fed into an FSK/ASK demodulator, data filter and data slicer. The RSSI (Received Signal Strength Indicator) signal and the raw digital output signal of the demodulator are available at the pins RSSI and on TEST3 (open drain output). The demodulated data signal Demod\_Out is fed into the digital control logic where it is evaluated and buffered as described in section [“Digital Control Logic” on page 32](#).

In transmit mode the fractional-N frequency synthesizer generates the TX frequency which is fed into the PA. In ASK mode the PA is modulated by the signal PA\_Enable. In FSK mode the PA is enabled and the signal TX\_DATA (FSK) modulates the fractional-N frequency synthesizer. The frequency deviation is digitally controlled and internally fixed to about  $\pm 19.5\text{kHz}$  (see [Table 6-1 on page 25](#) for exact values). The transmit data can also be buffered as described in section [“Digital Control Logic” on page 32](#). A lock detector within the synthesizer ensures that the transmission will only start if the synthesizer is locked.

In half-duplex mode the RX/TX switch can be used to combine the LNA input and the PA output to a single antenna with a minimum of losses.

Transparent modes without buffering of RX and TX data are also available to allow protocols and coding schemes other than the internal supported Manchester encoding, like PWM and pulse position coding.

### 5.1 Low-IF Receiver

The receive path consists of a fully integrated low-IF receiver. It fulfills the sensitivity, blocking, selectivity, supply voltage and supply current specification needed to manufacture an automotive key fob for RKE and PEG systems without the use of a SAW blocking filter (see [Figure 3-1 on page 7](#)). The receiver can be connected to the roof antenna in the car when using an additional blocking SAW front-end filter as shown in [Figure 4-1 on page 8](#).

At 433.92MHz the receiver has a typical system noise figure of 6.5dB, a system I1dB<sub>CP</sub> of  $-30\text{dBm}$  and a system IIP3 of  $-20\text{dBm}$ . The signal path is linear for disturbers up to the I1dB<sub>CP</sub> and there is hence no AGC or switching of the LNA needed to achieve a better blocking performance. This receiver uses an IF of about 226kHz (see [Section 14. “Electrical Characteristics: General” on page 61](#) number 2.10 for exact values), the typical image rejection is 30dB and the typical 3dB system bandwidth is 220kHz ( $f_{\text{IF}} = 226\text{kHz} \pm 110\text{kHz}$ ,  $f_{\text{lo\_IF}} = 116\text{kHz}$  and  $f_{\text{hi\_IF}} = 336\text{kHz}$ ). The demodulator needs a signal to noise ratio of 8dB for 20Kbit/s Manchester with  $\pm 19.5\text{kHz}$  frequency deviation in FSK mode, thus, the resulting sensitivity at 433.92MHz is typically  $-105.5\text{dBm}$ .

Due to the low phase noise and spurious of the synthesizer in receive mode<sup>(1)</sup> together with the eighth order integrated IF filter the receiver has a better selectivity and blocking performance than more complex double superhet receivers, without using external components and without numerous spurious receiving frequencies.

Note: 1.  $-120\text{dBC/Hz}$  at  $\pm 1\text{MHz}$  and  $-72\text{dBC}$  at  $\pm f_{\text{XTO}}$  at 433.92MHz

A low-IF architecture is also less sensitive to second-order intermodulation (IIP2) than direct conversion receivers where every pulse or amplitude modulated signal (especially the signals from TDMA systems like GSM) demodulates to the receiving signal band at second-order non-linearities.

## 5.2 Input Matching at RF\_IN

The measured input impedances as well as the values of a parallel equivalent circuit of these impedances can be seen in [Table 5-1](#). The highest sensitivity is achieved with power matching of these impedances to the source impedance of 50Ω.

**Table 5-1. Measured Input Impedances of the RF\_IN Pin**

$f_{RF}/\text{MHz}$	$Z_{in}(\text{RF\_IN})$	$R_{in_p}/C_{in_p}$
315	$(44-j233)\Omega$	$1278\Omega/2.1\text{pF}$
433.92	$(32-j169)\Omega$	$925\Omega/2.1\text{pF}$

The matching of the LNA Input to 50Ω was done with the circuit according to [Figure 5-1](#) and with the values of the matching elements given in [Table 5-2](#). The reflection coefficients were always  $\leq -10\text{dB}$ . Note that value changes of  $C_1$  and  $L_1$  may be necessary to compensate individual board layout parasitics. The measured typical FSK and ASK Manchester code sensitivities with a Bit Error Rate (BER) of  $10^{-3}$  are shown in [Table 5-3 on page 10](#) and [Table 5-4 on page 10](#). These measurements were done with multilayer inductors having quality factors according to [Table 5-2](#), resulting in estimated matching losses of 0.8dB at 315MHz and 0.8dB at 433.92MHz. These losses can be estimated when calculating the parallel equivalent resistance of the inductor with  $R_{loss} = 2 \times \pi \times f \times L \times Q_L$  and the matching loss with  $10 \log(1+R_{in_p}/R_{loss})$ .

With an ideal inductor, for example, the sensitivity at 433.92MHz/FSK/20Kbit/s/  $\pm 19.5\text{kHz}$ /Manchester can be improved from  $-105.5\text{dBm}$  to  $-106.7\text{dBm}$ . The sensitivity also depends on the values in the registers of the control logic which examines the incoming data stream. The examination limits must be programmed in control registers 5 and 6. The measurements in [Table 5-3](#) and [Table 5-4 on page 10](#) are based on the values of registers 5 and 6 according to [Table 11-3 on page 55](#).

**Figure 5-1. Input Matching to 50Ω**

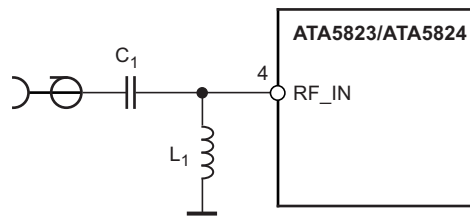

**Table 5-2. Input Matching to 50Ω**

$f_{RF}/\text{MHz}$	$C_1/\text{pF}$	$L_1/\text{nH}$	$Q_{L1}$
315	2.4	47	65
433.92	1.8	27	67

**Table 5-3. Measured Typical Sensitivity 433.92MHz, FSK,  $\pm 19.5\text{kHz}$ , Manchester, BER =  $10^{-3}$**

RF Frequency	BR_Range_0 1.0Kbit/s	BR_Range_0 2.4Kbit/s	BR_Range_1 5.0Kbit/s	BR_Range_2 10Kbit/s	BR_Range_3 20Kbit/s
315MHz	$-109.5\text{dBm}$	$-110.0\text{dBm}$	$-109.0\text{dBm}$	$-107.5\text{dBm}$	$-106.5\text{dBm}$
433.92MHz	$-108.5\text{dBm}$	$-109.0\text{dBm}$	$-108.0\text{dBm}$	$-106.5\text{dBm}$	$-105.5\text{dBm}$

**Table 5-4. Measured Typical Sensitivity 433.92 MHz, 100% ASK, Manchester, BER =  $10^{-3}$**

RF Frequency	BR_Range_0 1.0Kbit/s	BR_Range_0 2.4Kbit/s	BR_Range_1 5.0Kbit/s	BR_Range_2 10Kbit/s
315MHz	$-117.0\text{dBm}$	$-117.0\text{dBm}$	$-114.5\text{dBm}$	$-112.5\text{dBm}$
433.92MHz	$-116.0\text{dBm}$	$-116.0\text{dBm}$	$-113.5\text{dBm}$	$-111.5\text{dBm}$

### 5.3 Sensitivity versus Supply Voltage, Temperature and Frequency Offset

To calculate the behavior of a transmission system it is important to know the reduction of the sensitivity due to several influences. The most important are frequency offset due to crystal oscillator (XTO) and crystal frequency (XTAL) errors, temperature and supply voltage dependency of the noise figure and IF filter bandwidth of the receiver. Figure 5-2 shows the typical sensitivity at 433.92MHz/FSK/20Kbit/s/±19.5kHz/Manchester versus the frequency offset between transmitter and receiver at  $T_{amb} = -40^{\circ}\text{C}$ ,  $+25^{\circ}\text{C}$  and  $+105^{\circ}\text{C}$  and supply voltage  $V_S = V_{S1} = V_{S2} = 2.15\text{V}$ ,  $3.0\text{V}$  and  $3.6\text{V}$ .

**Figure 5-2. Measured Sensitivity 433.92MHz/FSK/20Kbit/s/±19.5kHz/Manchester versus Frequency Offset, Temperature and Supply Voltage**

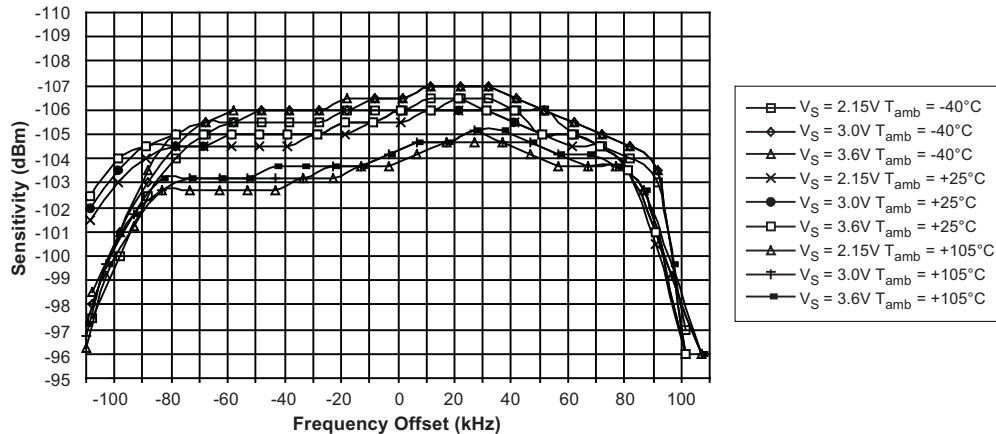

As can be seen in Figure 5-2 on page 11 the supply voltage has almost no influence on the sensitivity. The temperature has an influence of about  $+1.5/-0.7\text{dB}$  and a frequency offset of  $\pm 85\text{kHz}$  also influences by about  $\pm 1\text{dB}$ . All these influences, combined with the sensitivity of a typical IC ( $-105.5\text{dBm}$ ), are then within a range of  $-102.5\text{dBm}$  and  $-107\text{dBm}$  overtemperature, supply voltage and frequency offset. The integrated IF filter has an additional production tolerance of  $\pm 10\text{kHz}$ , hence, a frequency offset between the receiver and the transmitter of  $\pm 75\text{kHz}$  can be accepted for XTAL and XTO tolerances.

Note: For the demodulator used in the Atmel ATA5823/ATA5824, the tolerable frequency offset does not change with the data frequency, hence, the value of  $\pm 75\text{kHz}$  is valid for  $1\text{Kbit/s}$  to  $20\text{Kbit/s}$ .

This small sensitivity change over supply voltage, frequency offset and temperature is very unusual in such a receiver. It is achieved by an internal, very fast and automatic frequency correction in the FSK demodulator after the IF filter, which leads to a higher system margin. This frequency correction tracks the input frequency very quickly, if however, the input frequency makes a larger step (e.g., if the system changes between different communication partners), the receiver has to be restarted. This can be done by switching back to IDLE mode and then again to RX mode. For that purpose, an automatic mode is also available. This automatic mode switches to IDLE mode and back into RX mode every time a bit error occurs (see section “Digital Control Logic” on page 32).

### 5.4 Frequency Accuracy of the Crystals in Bi-directional RKE/PEG

The XTO is an amplitude regulated Pierce type oscillator with integrated load capacitors. The initial tolerances (due to the frequency tolerance of the XTAL, the integrated capacitors on XTAL1, XTAL2 and the XTO’s initial transconductance  $g_m$ ) can be compensated to a value within  $\pm 0.5\text{ppm}$  by measuring the CLK output frequency and tuning of  $f_{RF}$  by programming the control registers 2 and 3 (see Table 9-7 on page 34 and Table 9-10 on page 35). The XTO then has a remaining influence of less than  $\pm 2\text{ppm}$  overtemperature and supply voltage due to the bandgap controlled  $g_m$  of the XTO. Thus only  $2.5\text{ppm}$  add to the frequency stability of the used crystals overtemperature and aging.

The needed frequency stability of the used crystals **overtemperature and aging** is hence  $\pm 75\text{kHz}/433.92\text{MHz} - 2 \times \pm 2.5\text{ppm} = \pm 167.84\text{ppm}$  for  $433.92\text{MHz}$ . Thus, the used crystals in receiver and transmitter each need to be better than  $\pm 83.9\text{ppm}$  for  $433.92\text{MHz}$ .

## 5.5 Frequency Accuracy of the Crystals in a Combined RKE/PEG and TPM System

In a tire pressure measurement system working at 433.92MHz and using a TPM transmitter Atmel® ATA5757 and a transceiver Atmel ATA5824 as a receiver, the higher frequency tolerances and the tolerance of the frequency deviation of this transmitter has to be considered.

In the TPM transmitter the crystal has an frequency error overtemperature  $-40^{\circ}\text{C}$  to  $+125^{\circ}\text{C}$ , aging and tolerance of  $\pm 80\text{ppm}$  ( $\pm 34.7\text{kHz}$  at 433.92MHz). The tolerances of the XTO, the capacitors used for FSK-Modulation and the stray capacitors, causing an additional frequency error of  $\pm 30\text{ppm}$  ( $\pm 13\text{kHz}$  at 433.92MHz). The frequency deviation of such a transmitter varies between  $\pm 16\text{kHz}$  and  $\pm 24\text{kHz}$ , since a higher frequency deviation is equivalent to an frequency error, this has to be considered as an additional  $\pm 24\text{kHz} - \pm 19.5\text{kHz} = \pm 4.5\text{kHz}$  frequency tolerance. All tolerances added, these transmitters have a worst case frequency offset of  $\pm 52.2\text{kHz}$ .

For the transceiver in the car a tolerance of  $\pm 75\text{kHz} - \pm 52.2\text{kHz} = \pm 22.8\text{kHz}$  ( $\pm 52.5\text{ppm}$ ) remains. The needed frequency stability of the used crystals **overtemperature and aging** is  $\pm 52.5\text{ppm} - \pm 2.5\text{ppm} = \pm 50\text{ppm}$ . The aging of such a crystal is  $\pm 10\text{ppm}$  leaving reasonable  $\pm 40\text{ppm}$  for the temperature dependency of the crystal frequency in the car.

Since the transceiver in the car is able to receive these TPM transmitter signals with high frequency offsets, the component specification in the key can be largely relaxed.

This system calculation is based on worst case tolerances of all the components, this leads in practice to a system with margin.

For a 315MHz TPM system using a TPM transmitter Atmel ATA5756 and a transceiver Atmel ATA5823 as receiver the same calculation must be done, but since the RF frequency is lower, every ppm of crystal tolerances results in less frequency offset and either the system can have higher tolerances or a higher margin there.

## 5.6 RX Supply Current versus Temperature and Supply Voltage

Table 5-5 shows the typical supply current at 433.92MHz of the transceiver in RX mode versus supply voltage and temperature with  $V_S = V_{S1} = V_{S2}$ . As can be seen the supply current at  $V_S = 2.15\text{V}$  and  $T_{\text{amb}} = -40^{\circ}\text{C}$  is less than at  $V_S = 3\text{V}/T_{\text{amb}} = 25^{\circ}$  which helps to enlarge the battery lifetime within a key fob application because this is also the operation point where a lithium cell has the worst performance. The typical supply current at 315MHz in RX mode is about the same as for 433.92MHz.

**Table 5-5. Measured 433.92MHz Receive Supply Current in FSK mode**

$V_S = V_{S1} = V_{S2}$	2.15V	3.0V	3.6V
$T_{\text{amb}} = -40^{\circ}\text{C}$	8.2mA	8.8mA	9.2mA
$T_{\text{amb}} = 25^{\circ}\text{C}$	9.7mA	10.3mA	10.8mA
$T_{\text{amb}} = 105^{\circ}\text{C}$	11.2mA	11.9mA	12.4mA

## 5.7 Blocking, Selectivity

As can be seen in [Figure 5-3](#), [Figure 5-4](#) and [Figure 5-5 on page 13](#), the receiver can receive signals 3dB higher than the sensitivity level in presence of large blockers of  $-44.5\text{dBm}/-36.0\text{dBm}$  with small frequency offsets of  $\pm 1/\pm 10\text{MHz}$ .

[Figure 5-3](#) and [Figure 5-4 on page 13](#) shows the close-in and narrow-band blocking and [Figure 5-5 on page 13](#) the wide-band blocking characteristic. The measurements were done with a useful signal of  $433.92\text{MHz}/\text{FSK}/20\text{Kbit/s}/\pm 19.5\text{kHz}/\text{Manchester}$  with a level of  $-105.5\text{dBm} + 3\text{dB} = -102.5\text{dBm}$  which is 3dB above the sensitivity level. The figures show by how much a continuous wave signal can be larger than  $-102.5\text{dBm}$  until the BER is higher than  $10^{-3}$ . The measurements were done at the  $50\Omega$  input according to [Figure 5-1 on page 10](#). At 1MHz, for example, the blocker can be 58dBC higher than  $-102.5\text{dBm}$  which is  $-102.5\text{dBm} + 58\text{dBC} = -44.5\text{dBm}$ . These blocking figures, together with the good intermodulation performance, avoid the additional need of a SAW filter in the key fob application.

**Figure 5-3. Close In 3dB Blocking Characteristic and Image Response at 433.92MHz**

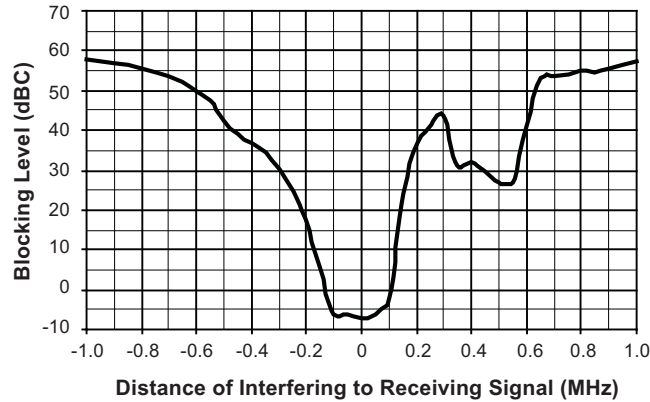

**Figure 5-4. Narrow Band 3dB Blocking Characteristic at 433.92MHz**

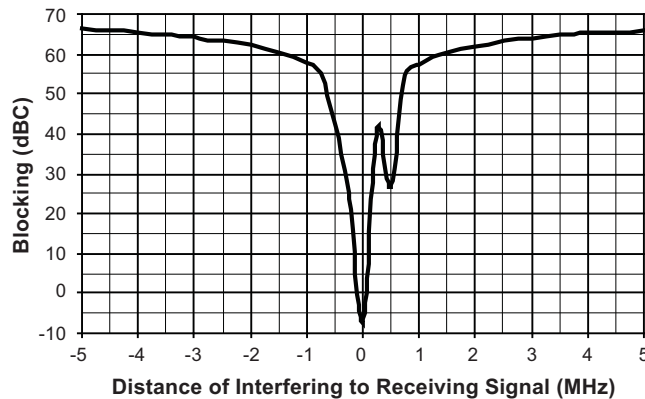

**Figure 5-5. Wide Band 3dB Blocking Characteristic at 433.92MHz**

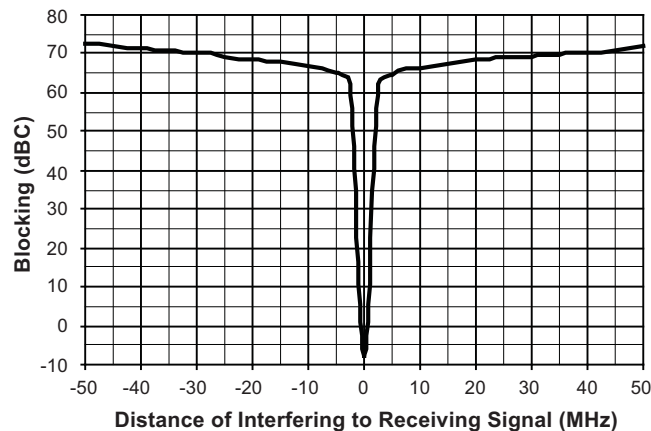

Table 5-6 shows the blocking performance measured relative to  $-102.5\text{dBm}$  for some frequencies. Note that sometimes the blocking is measured relative to the sensitivity level  $-105.5\text{dBm}$  (denoted dBS) instead of the carrier  $-102.5\text{dBm}$  (denoted dBC).

**Table 5-6. Blocking 3 dB Above Sensitivity Level with BER <math>10^{-3}</math>**

Frequency Offset	Blocker Level	Blocking
+0.75MHz	$-47.5\text{dBm}$	55.0dBC/58.0dBS
-0.75MHz	$-47.5\text{dBm}$	55.0dBC/58.0dBS
+1.0MHz	$-44.5\text{dBm}$	58.0dBC/61.0dBS
-1.0MHz	$-44.5\text{dBm}$	58.0dBC/61.0dBS
+1.5MHz	$-42.0\text{dBm}$	60.5dBC/63.5dBS
-1.5MHz	$-42.0\text{dBm}$	60.5dBC/63.5dBS
+10MHz	$-35.5\text{dBm}$	67.0dBC/70.0dBS
-10MHz	$-35.5\text{dBm}$	67.0dBC/70.0dBS

The Atmel® ATA5823/ATA5824 can also receive FSK and ASK modulated signals if they are much higher than the I1dBCP. It can typically receive useful signals at  $+10\text{dBm}$ . This is often referred to as the nonlinear dynamic range which is the maximum to minimum receiving signal which is  $115.5\text{dB}$  for  $433.92\text{MHz/FSK/20Kbit/s}/\pm 19.5\text{kHz/Manchester}$ . This value is useful if two transceivers have to communicate and are very close to each other.

In a keyless entry system there is another blocking characteristic that has to be considered. A keyless entry system has a typical service range of about  $30\text{m}$  with a receiver sensitivity of about  $-106\text{dBm}$  to  $-109\text{dBm}$ . In some cases, large blockers limit this service range, and it is important to know how large this blockers can be until the system doesn't work anymore and the user has to use its key. With a recommended sensitivity of about  $-85\text{dBm}$ , the system works just around the car. Figure 5-6 and Figure 5-7 on page 15 show the blocking performance in this important case with a useful signal of  $-85\text{dBm}$   $433.92\text{MHz/FSK/20Kbit/s}/\pm 19.5\text{kHz/Manchester}$ .

As can be seen the system works even with blockers above the compression point. This is due to a wide bandwidth automatic gain control that begins to work if blockers above the compression point are at the antenna input and increasing the current in the LNA/Mixer to get a better compression point needed to handle these large blockers.

**Figure 5-6.  $\pm 2.5\text{MHz}$  Blocking Characteristic for  $-85\text{dBm}$  Useful Signal at  $433.92\text{MHz}$**

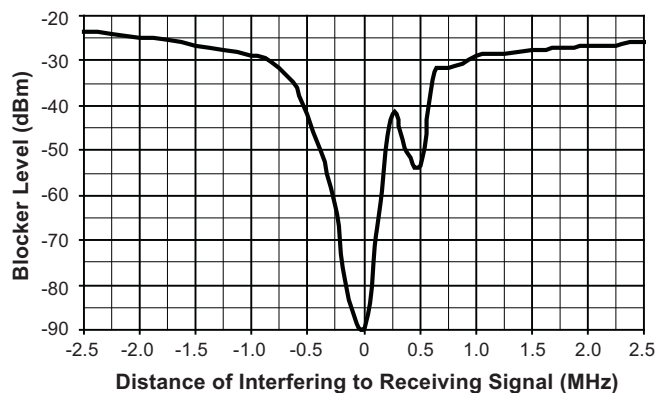
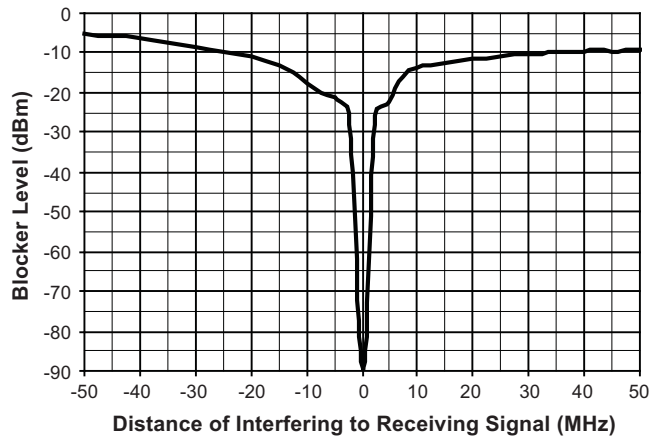

Figure 5-7.  $\pm 50$ MHz Blocking Characteristic for  $-85$ dBm Useful Signal at 433.92MHz



This high blocking performance makes it even possible for some applications using quarter wave whip antennas to use a simple LC band-pass filter instead of a SAW filter in the receiver. When designing such a LC filter, take into account that the 3dB blocking at  $433.92\text{MHz}/2 = 216.96\text{MHz}$  is 42dBC and at  $433.92\text{MHz}/3 = 144.64\text{MHz}$  is 47dBC. And especially that at  $3 \times (433.92\text{MHz} + 226\text{kHz}) + 226\text{kHz} = 1302.664\text{MHz}$  the receiver has a second LO harmonic receiving frequency with only 17dBC blocking.

## 5.8 Inband Disturbance, Data Filter, Quasi-peak Detector, Data Slicer

If a disturbing signal falls into the received band, or a blocker is not a continuous wave, the performance of a receiver strongly depends on the circuits after the IF filter. Hence the demodulator, data filter and data slicer are important in that case.

The data filter of the Atmel<sup>®</sup> ATA5823/ATA5824 implies a quasi-peak detector. This results in a good suppression of above mentioned disturbers and exhibits a good carrier to noise performance. The required ratio of useful signal to disturbing signal, at a BER of  $10^{-3}$  is less than 12dB in ASK mode and less than 3dB (BR\_Range\_0 ... BR\_Range\_2) and 6dB (BR\_Range\_3) in FSK mode. Due to the many different possible waveforms these numbers are measured for signal as well as for disturbers with peak amplitude values. Note that these values are worst case values and are valid for any type of modulation and modulating frequency of the disturbing signal as well as the receiving signal. For many combinations, lower carrier to disturbing signal ratios are needed.

## 5.9 TEST3 Output

The internal raw output signal of the demodulator Demod\_Out is available at pin TEST3. TEST3 is an open drain output and must be connected to a pull-up resistor if it is used (typically  $100\text{k}\Omega$ ), otherwise no signal is present at that pin. This signal is mainly used for debugging purposes during the setup of a new application, since the received data signal can be seen there without any digital processing.



## 5.10 RSSI Output

The output voltage of the pin RSSI is an analog voltage, proportional to the input power level. Using the RSSI output signal, the signal strength of different transmitters can be distinguished. The usable dynamic range of the RSSI amplifier is 70dB, the input power range  $P_{RF\_IN}$  is  $-115\text{dBm}$  to  $-45\text{dBm}$  and the gain is  $8\text{mV/dB}$ . Figure 5-8 on page 16 shows the RSSI characteristic of a typical device at  $433.92\text{MHz}$  with  $V_{S1} = V_{S2} = 2.15\text{V}$  to  $3.6\text{V}$  and  $T_{amb} = -40^{\circ}\text{C}$  to  $+105^{\circ}\text{C}$  with a matched input according to Table 5-2 on page 10 and Figure 5-1 on page 10. At  $315\text{MHz}$  about  $1\text{dB}$  less signal level is needed for the same RSSI results.

Figure 5-8. Typical RSSI Characteristic at  $433.92\text{MHz}$  versus Temperature and Supply Voltage

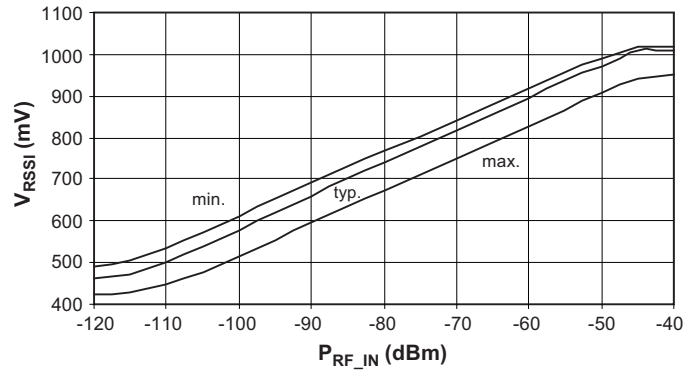

## 5.11 Frequency Synthesizer and Channel Selection

The synthesizer is a fully integrated fractional-N design with internal loop filters for receive and transmit mode. The XTO frequency  $f_{XTO}$  is the reference frequency FREF for the synthesizer. The bits FR0 to FR12 in control registers 2 and 3 (see Table 9-7 on page 34 and Table 9-10 on page 35) are used to adjust the deviation of  $f_{XTO}$ . In half-duplex transmit mode, at  $433.92\text{MHz}$ , the carrier has a phase noise of  $-111\text{dBC/Hz}$  at  $1\text{MHz}$  and spurious at FREF of  $-70\text{dBC}$  with a high PLL loop bandwidth allowing the direct modulation of the carrier with  $20\text{Kbit/s}$  Manchester data. Due to the closed loop modulation, any spurious caused by this modulation are effectively filtered out as can be seen in Figure 5-11 on page 18. In RX mode the synthesizer has a phase noise of  $-120\text{dBC/Hz}$  at  $1\text{MHz}$  and spurious of  $-72\text{dBC}$ .

The initial tolerances of the crystal oscillator due to crystal frequency tolerances, internal capacitor tolerances and the parasitics of the board have to be compensated at manufacturing setup with control registers 2 and 3 as can be seen in Table 6-1 on page 25. The other control words for the synthesizer needed for ASK, FSK and receive/transmit switching are calculated internally. The RF (Radio Frequency) resolution is equal to the XTO frequency divided by 16384 which is  $777.1\text{Hz}$  at  $315.0\text{MHz}$  and  $808.9\text{Hz}$  at  $433.92\text{MHz}$ .

The frequency control word FREQ in control registers 2 and 3 can be programmed in the range of 1000 to 6900, hence every frequency within the  $433\text{MHz}$  ISM bands can be programmed as receive and as transmit frequency and the position of channels within these ISM bands can be chosen arbitrarily (see Table 6-1 on page 25).

Care must be taken regarding the harmonics of the CLK output signal as well as to the harmonics produced by a microprocessor clocked with it, since these harmonics can disturb the reception of signals. In a single channel system using  $\text{FREQ} = 3803$  to  $4053$  ensures that harmonics of this signal, do not disturb the receive mode.

## 5.12 FSK/ASK Transmission

Due to the fast modulation capability of the synthesizer and the high resolution, the carrier can be internally FSK modulated which simplifies the application of the transceiver. The deviation of the transmitted signal is  $\pm 24$  digital frequency steps of the synthesizer which is equal to  $\pm 18.65\text{kHz}$  for 315MHz and  $\pm 19.41\text{kHz}$  for 433.92MHz.

Due to closed loop modulation with PLL filtering, the modulated spectrum is very clean, meeting ETSI and CEPT regulations when using a simple LC filter for the power amplifier harmonics as it is shown in Figure 4-1. In ASK mode the frequency is internally connected to the center of the FSK transmission and the power amplifier is switched on and off to perform the modulation. Figure 5-9 to Figure 5-11 on page 18 show the spectrum of the FSK modulation with pseudo-random data with 20Kbit/s/ $\pm 19.41\text{kHz}$ /Manchester and 5dBm output power.

**Figure 5-9. FSK-modulated TX Spectrum (433.92MHz/20Kbit/s/ $\pm 19.41\text{kHz}$ /Manchester Code)**

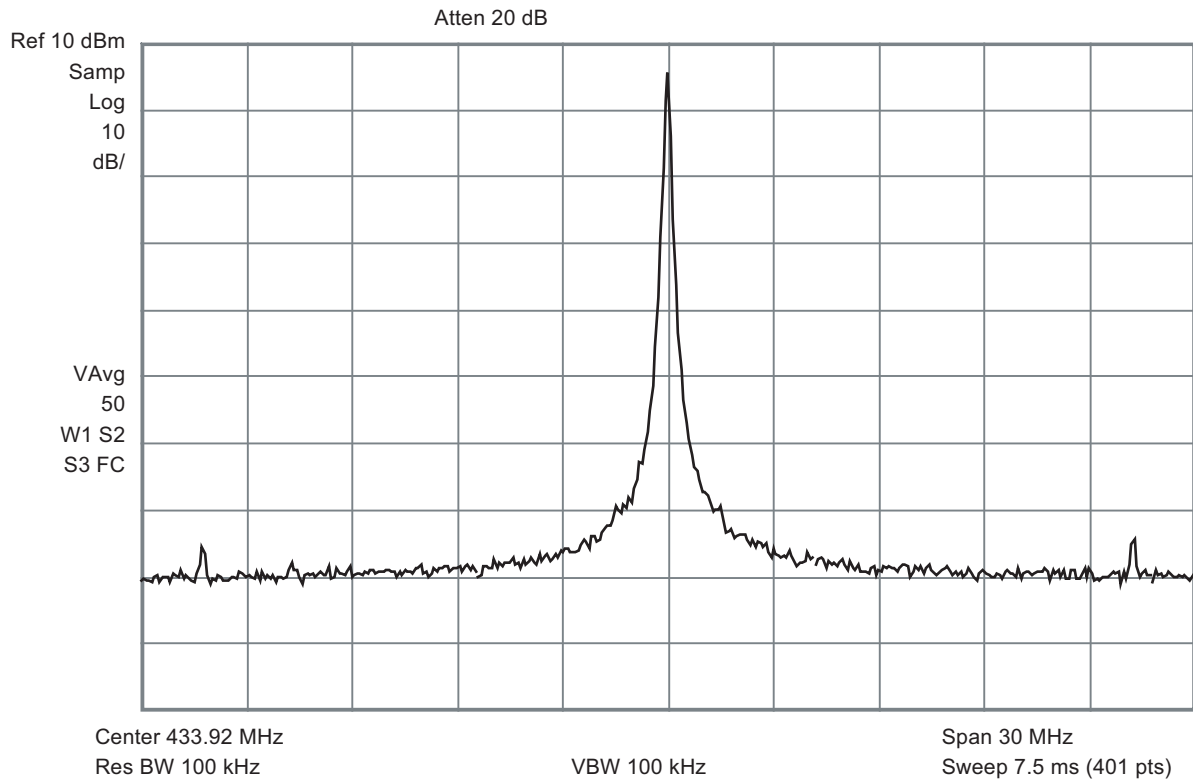

**Figure 5-10. Unmodulated TX Spectrum 433.92MHz - 19.41kHz ( $f_{FSK\_L}$ )**

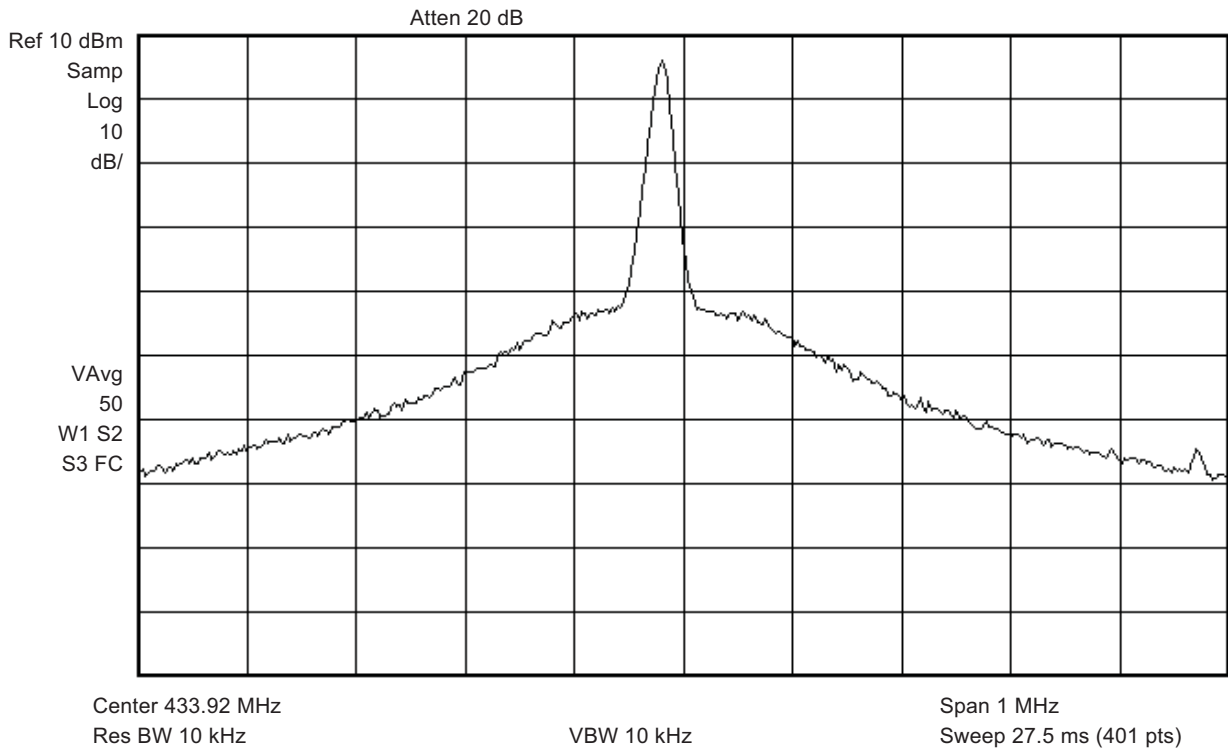

**Figure 5-11. FSK-modulated TX Spectrum (433.92MHz/20Kbit/s/±19.41kHz/Manchester Code)**

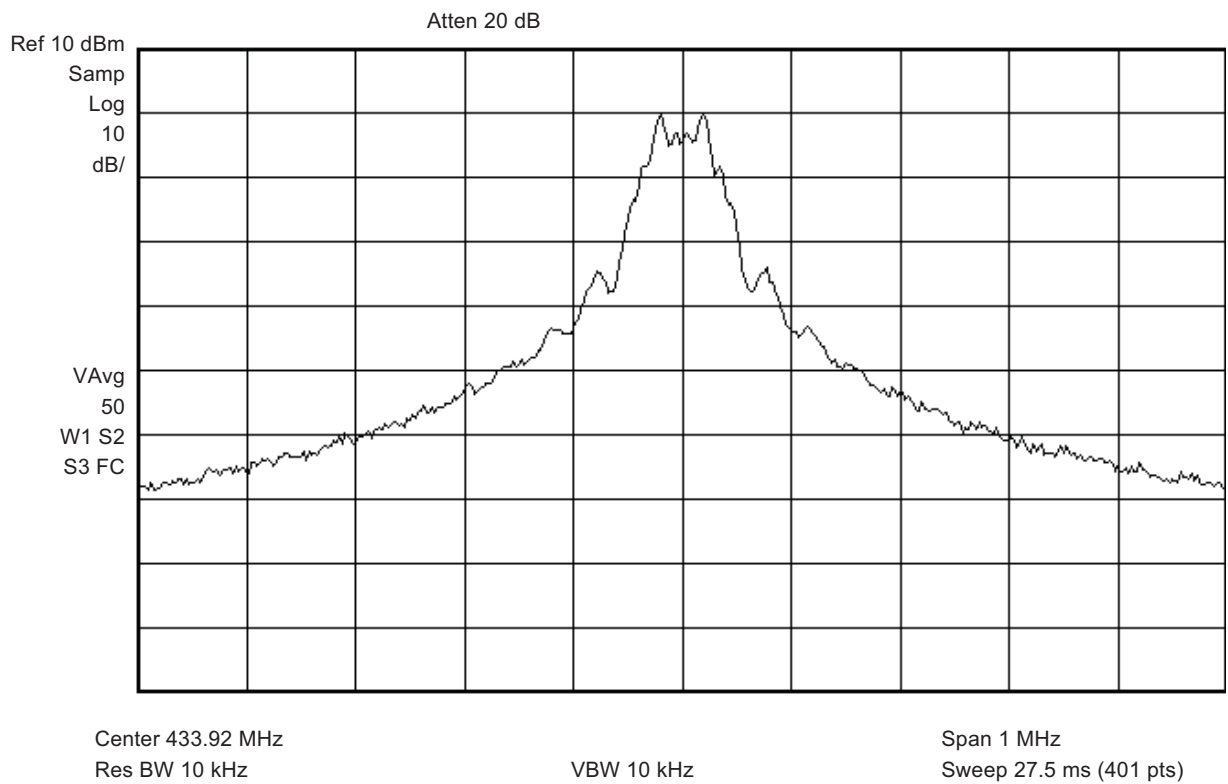

## 5.13 Output Power Setting and PA Matching at RF\_OUT

The Power Amplifier (PA) is a single-ended open collector stage which delivers a current pulse which is nearly independent of supply voltage, temperature and tolerances due to band-gap stabilization. Resistor  $R_1$  (see [Figure 5-12 on page 20](#)) sets a reference current which controls the current in the PA. A higher resistor value results in a lower reference current, a lower output power and a lower current consumption of the PA. The usable range of  $R_1$  is 15k $\Omega$  to 56k $\Omega$ . The PWR\_H pin switches the output power range between about 0dBm to 5dBm (PWR\_H = GND) and 5dBm to 10dBm (PWR\_H = AVCC) by multiplying this reference current with a factor 1 (PWR\_H = GND) and 2.5 (PWR\_H = AVCC) which corresponds to about 5dB more output power.

If the PA is switched off in TX mode, the current consumption without output stage and with  $V_{S1} = V_{S2} = 3V$ ,  $T_{amb} = 25^\circ C$  is typically 6.95mA for 315MHz and 433.92MHz.

The maximum output power is achieved with optimum load resistances  $R_{Lopt}$  according to [Table 5-7 on page 20](#). The compensation of the 1.0pF output capacitance of the RF\_OUT pin will be achieved by absorbing it into the matching network, consisting of  $L_1$ ,  $C_1$ ,  $C_3$  as shown in [Figure 5-12 on page 20](#). There must be also a low resistive DC path to AVCC to deliver the DC current of the power amplifier's last stage. The matching of the PA output was done with the circuit according to [Figure 5-12 on page 20](#) with the values in [Table 5-7](#). Note that value changes of these elements may be necessary to compensate individual board layout parasitics.

Example:

According to [Table 5-7 on page 20](#), with a frequency of 433.92MHz and output power of 11dBm, the overall current consumption is typically 17.8mA. Hence the PA needs 17.8mA - 6.95mA = 10.85mA in this mode which corresponds to an overall power amplifier efficiency of the PA of  $(10^{(11dBm/10)} \times 1mW)/(3V \times 10.85mA) \times 100\% = 38.6\%$  in this case.

Using a higher resistor in this example of  $R_1 = 1.091 \times 22k\Omega = 24k\Omega$  results in 9.1% less current in the PA of 10.85mA/1.091 = 9.95mA and  $10 \times \log(1.091) = 0.38dB$  less output power if using a new load resistance of  $300\Omega \times 1.091 = 327\Omega$ . The resulting output power is then 11dBm - 0.38dB = 10.6dBm and the overall current consumption is 6.95mA + 9.95mA = 16.9mA.

The values of [Table 5-7 on page 20](#) were measured with standard multi-layer chip inductors with quality factors Q according to [Table 5-7 on page 20](#).

Looking to the 433.92MHz/11dBm case with the quality factor of  $Q_{L1} = 43$  the loss in this inductor  $L_1$  is estimated with the parallel equivalent resistance of the inductor  $R_{loss} = 2 \times \pi \times f \times L_1 \times Q_{L1}$  and the matching loss with  $10 \log(1 + R_{Lopt}/R_{loss})$  which is equal to 0.32dB losses in this inductor. Taking this into account the PA efficiency is then 42% instead of 38.6%.

Be aware that the high power mode (PWR\_H = AVCC) can only be used with a supply voltage higher than 2.7V, whereas the low power mode (PWR\_H = GND) can be used down to 2.15V as can be seen in the section "[Electrical Characteristics: General](#)" on page 61.

The supply blocking capacitor  $C_2$  (10nF) in [Figure 5-12 on page 20](#) has to be placed close to the matching network because of the RF current flowing through it.

An internal programmable resistor SETPWR is programmable with the control register 8, described in [Table 9-25 on page 39](#). It can be used in conjunction with an external resistor to adjust the output power by connection it. To do that the output power should be adjusted with an external resistor about 50% lower than needed for the target output power and reduced with the programmable resistor during production test until the target power is as close as possible to the target. For example, if using 433.92MHz at 5dBm, a resistor of 12k instead of 24k is used and values of PWSET between 25 and 29 can be used to achieve an output power within 5dBm  $\pm 0.5dB$  over production. Note that this resistor is temperature stable but has tolerances of  $\pm 20\%$  and introduces, therefore, additional output power tolerances, it is recommended to adjust output power during the production test if using the SETPWR resistor.

**Figure 5-12. Power Setting and Output Matching**

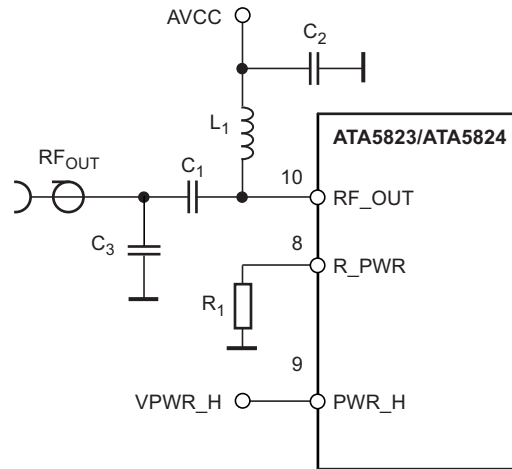

**Table 5-7. Measured Output Power and Current Consumption with  $V_{S1} = V_{S2} = 3V$ ,  $T_{amb} = 25^{\circ}C$**

Frequency (MHz)	TX Current (mA)	Output Power (dBm)	R1 (k $\Omega$ )	VPWR_H	$R_{Lopt}$ ( $\Omega$ )	$L_1$ (nH)	$Q_{L1}$	$C_1$ (pF)	$C_3$ (pF)
315	8.5	0.4	56	0	2500	82	28	1.5	0
315	10.5	5.7	27	0	920	68	32	2.2	0
315	16.7	10.5	27	AVCC	350	56	35	3.9	0
433.92	8.6	0.1	56	0	2300	56	40	0.75	0
433.92	11.2	6.2	22	0	890	47	38	1.5	0
433.92	17.8	11	22	AVCC	300	33	43	2.7	0

## 5.14 Output Power and TX Supply Current versus Supply Voltage and Temperature

Table 5-8 shows the measurement of the output power for a typical device with  $V_{S1} = V_{S2} = V_S$  in the 433.92MHz and 6.2dBm case versus temperature and supply voltage measured according to Figure 5-12 on page 20 with components according to Table 5-7 on page 20. As opposed to the receiver sensitivity the supply voltage has here the major impact on output power variations because of the large signal behavior of a power amplifier. Thus a 5V system using the internal voltage regulator shows much less variation than a 2.15V to 3.6V battery system because the AVCC supply voltage is  $3.25V \pm 0.25V$  for a 5V system.

The reason is that the amplitude at the output RF\_OUT with optimum load resistance is  $AVCC - 0.4V$  and the power is proportional to  $(AVCC - 0.4V)^2$  if the load impedance is not changed. This means that the theoretical output power reduction if reducing the supply voltage from 3.0V to 2.15V is  $10 \log ((3V - 0.4V)^2 / (2.15V - 0.4V)^2) = 3.4dB$ . Table 5-8 shows that principle behavior in the measurements. This is not the same case for higher voltages, since here, increasing the supply voltage from 3V to 3.6V should theoretical increase the power by 1.8dB, but only 0.9dB in the measurements shows that the amplitude does not increase with the supply voltage because the load impedance is optimized for 3V and the output amplitude stays more constant because of the current source nature of the output.

**Table 5-8. Measured Output Power and Supply Current at 433.92MHz, PWR\_H = GND**

$V_S = V_{S1} = V_{S2}$	2.15V	3.0V	3.6V
$T_{amb} = -40^{\circ}\text{C}$	9.25mA 3.2dBm	10.19mA 5.5dBm	10.78mA 6.2dBm
$T_{amb} = +25^{\circ}\text{C}$	10.2mA 3.4dBm	11.19mA 6.2dBm	11.79mA 7.1dBm
$T_{amb} = +105^{\circ}\text{C}$	10.9mA 3.0dBm	12.02mA 5.4dBm	12.73mA 6.3dBm

Table 5-9 shows the relative changes of the output power of a typical device compared to 3.0V/25°C. As can be seen, a temperature change to -40°C as well as to +105°C reduces the power by less than 1dB due to the band-gap regulated output current. Measurements of all the cases in Table 5-7 on page 20 overtemperature and supply voltage have shown about the same relative behavior as shown in Table 5-9.

**Table 5-9. Measurements of Typical Output Power Relative to 3V/25°C**

$V_S = V_{S1} = V_{S2}$	2.15V	3.0V	3.6V
$T_{amb} = -40^{\circ}\text{C}$	-3.0dB	-0.7dB	0dB
$T_{amb} = +25^{\circ}\text{C}$	-2.8dB	0dB	+0.9dB
$T_{amb} = +105^{\circ}\text{C}$	-3.2dB	-0.8dB	+0.1dB

## 5.15 RX/TX Switch

The RX/TX switch decouples the LNA from the PA in TX mode, and directs the received power to the LNA in RX mode. To do this, it has a low impedance to GND in TX mode and a high impedance to GND in RX mode. The pin 38 (RX\_TX2) must always be connected to GND in the application. To design a proper RX/TX decoupling a linear simulation tool for radio frequency design together with the measured device impedances of Table 5-1 on page 10, Table 5-7 on page 20, Table 5-10 on page 21 and Table 5-11 on page 22 should be used. The exact element values have to be found on board. Figure 5-13 on page 21 shows an approximate equivalent circuit of the switch. The principal switching operation is described here according to the application of Figure 3-1 on page 7. The application of Figure 4-1 on page 8 works similarly.

**Table 5-10. Impedance of the RX/TX Switch RX\_TX2 Shorted to GND**

Frequency	Z(RX_TX1) TX mode	Z(RX_TX1) RX mode
315MHz	$(4.8 + j3.2)\Omega$	$(11.3 - j214)\Omega$
433.92MHz	$(4.5 + j4.3)\Omega$	$(10.3 - j153)\Omega$

**Figure 5-13. Equivalent Circuit of the Switch**

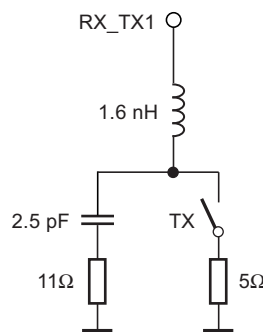

## 5.16 Matching Network in TX Mode

In TX mode the 20mm long and 0.4mm wide transmission line which is much shorter than  $\lambda/4$  is approximately switched in parallel to the capacitor  $C_9$  to GND. The antenna connection between  $C_8$  and  $C_9$  has an impedance of about  $50\Omega$  looking from the transmission line into the loop antenna with pin RF\_OUT,  $L_2$ ,  $C_{10}$ ,  $C_8$  and  $C_9$  connected (using a  $C_9$  without the added 7.6pF capacitor as discussed later). The transmission line can be approximated with a 16nH inductor in series with a  $1.5\Omega$  resistor, the closed switch can be approximated according to Table 5-10 with the series connection of 1.6nH and  $5\Omega$  in this mode. To have a parallel resonant high impedance circuit with little RF power going into it looking, from the loop antenna into the transmission line a capacitor of about 7.6pF to GND is needed at the beginning of the transmission line (this capacitor is later absorbed into  $C_9$ , which is then higher as needed for  $50\Omega$  transformation). To keep the  $50\Omega$  impedance in RX mode at the end of this transmission line  $C_7$  has to be also about 7.6pF. This reduces the TX power by about 0.5dB at 433.92MHz compared to the case where the LNA path is completely disconnected.

## 5.17 Matching Network in RX Mode

In RX mode the RF\_OUT pin has a high impedance of about  $7k\Omega$  in parallel with 1.0pF at 433.92MHz as can be seen in Table 5-11 on page 22. This together with the losses of the inductor  $L_2$  with 120nH and  $Q_{L2} = 25$  gives about  $3.7k\Omega$  loss impedance at RF\_OUT. Since the optimum load impedance in TX mode for the power amplifier at RF\_OUT is  $890\Omega$  the loss associated with the inductor  $L_2$  and the RF\_OUT pin can be estimated to be  $10 \times \log(1 + 890/3700) = 0.95\text{dB}$  compared to the optimum matched loop antenna without  $L_2$  and RF\_OUT. The switch represents, in this mode at 433.92MHz, about an inductor of 1.6nH in series with the parallel connection of 2.5pF and  $2.0k\Omega$ . Since the impedance level at pin RX\_TX1 in RX mode is about  $50\Omega$  there is only a negligible damping of the received signal by about 0.1dB. When matching the LNA to the loop antenna the transmission line and the 7.6pF part of  $C_9$  has to be taken into account when choosing the values of  $C_{11}$  and  $L_1$  so that the impedance seen from the loop antenna into the transmission line with the 7.6pF capacitor connected is  $50\Omega$ .

Since the loop antenna in RX mode is loaded by the LNA input impedance the loaded Q of the loop antenna is lowered by about a factor of 2 in RX mode hence the antenna bandwidth is higher than in TX mode.

Table 5-11. Impedance RF\_OUT Pin in RX mode

Frequency	Z(RF_OUT)RX	$R_p//C_p$
315MHz	$36\Omega - j 502\Omega$	$7k\Omega//1.0\text{pF}$
433.92MHz	$19\Omega - j 366\Omega$	$7k\Omega//1.0\text{pF}$

Note that if matching to  $50\Omega$ , like in Figure 4-1 on page 8, a high Q wire wound inductor with a  $Q > 70$  should be used for  $L_2$  to minimize its contribution to RX losses which will otherwise be dominant. The RX and TX losses will be in the range of 1.0dB there.

## 6. XTO

The XTO is an amplitude regulated Pierce oscillator type with integrated load capacitances ( $2 \times 18\text{pF}$  with a tolerance of  $\pm 17\%$ ) hence  $C_{L\text{min}} = 7.4\text{pF}$  and  $C_{L\text{max}} = 10.6\text{pF}$ . The XTO oscillation frequency  $f_{\text{XTO}}$  is the reference frequency FREF for the fractional-N synthesizer. When designing the system in terms of receiving and transmitting frequency offset the accuracy of the crystal and XTO have to be considered.

The synthesizer can adjust the local oscillator frequency for the initial frequency error in  $f_{\text{XTO}}$ . This is done at nominal supply voltage and temperature with the control registers 2 and 3 (see [Table 9-7 on page 34](#) and [Table 9-10 on page 35](#)). The remaining local oscillator tolerance at nominal supply voltage and temperature is then  $< \pm 0.5\text{ppm}$ . The XTO's gm has very low influence of less than  $\pm 2\text{ppm}$  on the frequency at nominal supply voltage and temperature.

In a single channel system less than  $\pm 150\text{ppm}$  should be corrected to avoid that harmonics of the CLK output disturb the receive mode. If the CLK is not used, or carefully layouted on the application PCB (as needed for multi channel systems), more than  $\pm 150\text{ppm}$  can be compensated.

The additional XTO pulling is only  $\pm 2\text{ppm}$ , overtemperature and supply voltage. The XTAL versus temperature and its aging is then the main source of frequency error in the local oscillator.

The XTO frequency depends on XTAL properties and the load capacitances  $C_{L1,2}$  at pin XTAL1 and XTAL2. The pulling of  $f_{\text{XTO}}$  from the nominal  $f_{\text{XTAL}}$  is calculated using the following formula

$$P = \frac{C_m}{2} \times \frac{C_{LN} - C_L}{(C_0 + C_{LN}) \times (C_0 + C_L)} \times 10^6 \text{ ppm.}$$

$C_m$  is the crystal's motional,  $C_0$  the shunt and  $C_{LN}$  the nominal load capacitance of the XTAL found in its datasheet.  $C_L$  is the total actual load capacitance of the crystal in the circuit and consists of  $C_{L1}$  and  $C_{L2}$  in series connection.

**Figure 6-1. XTAL with Load Capacitances**

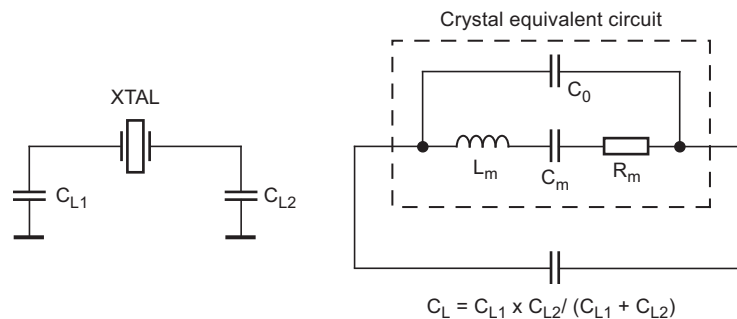

With  $C_m \leq 14\text{fF}$ ,  $C_0 \geq 1.5\text{pF}$ ,  $C_{LN} = 9\text{pF}$  and  $C_L = 7.4\text{pF}$  to  $10.6\text{pF}$  the pulling amounts to  $P \leq \pm 100\text{ppm}$  and with  $C_m \leq 7\text{fF}$ ,  $C_0 \geq 1.5\text{pF}$ ,  $C_{LN} = 9\text{pF}$  and  $C_L = 7.4\text{pF}$  to  $10.6\text{pF}$  the pulling is  $P \leq \pm 50\text{ppm}$ .

Since typical crystals have less than  $\pm 50\text{ppm}$  tolerance at  $25^\circ\text{C}$ , the compensation is not critical and can, in both cases, be done with the  $\pm 150\text{ppm}$ .

$C_0$  of the XTAL has to be lower than  $C_{L\text{min}}/2 = 3.7\text{pF}$  for a Pierce oscillator type in order to not enter the steep region of pulling versus load capacitance where there is a risk of an unstable oscillation.

To ensure proper start-up behavior the small signal gain, and thus the negative resistance provided by this XTO at start is very large. For example oscillation starts up, even in worst case, with a crystal series resistance of  $1.5\text{k}\Omega$  at  $C_0 \leq 2.2\text{pF}$  with this XTO. The negative resistance is approximately given by

$$\text{Re}\{Z_{\text{XTOcore}}\} = \text{Re}\left\{\frac{Z_1 \times Z_3 + Z_2 \times Z_3 + Z_1 \times Z_2 \times Z_3 \times g_m}{Z_1 + Z_2 + Z_3 + Z_1 \times Z_2 \times g_m}\right\}$$

with  $Z_1, Z_2$  as complex impedances at pin XTAL1 and XTAL2 hence

$$Z_1 = -j/(2 \times \pi \times f_{\text{XTO}} \times C_{L1}) + 5\Omega \text{ and } Z_2 = -j/(2 \times \pi \times f_{\text{XTO}} \times C_{L2}) + 5\Omega.$$

$Z_3$  consists of crystals  $C_0$  in parallel with an internal  $110\text{k}\Omega$  resistor hence

$$Z_3 = -j/(2 \times \pi \times f_{\text{XTO}} \times C_0) / 110\text{k}\Omega, g_m \text{ is the internal transconductance between XTAL1 and XTAL2 with typically } 19\text{ms at } 25^\circ\text{C}.$$



With  $f_{XTO} = 13.5\text{MHz}$ ,  $g_m = 19\text{ms}$ ,  $C_L = 9\text{pF}$ ,  $C_0 = 2.2\text{pF}$  this results in a negative resistance of about  $2\text{k}\Omega$ . The worst case for technological, supply voltage and temperature variations is then for  $C_0 \leq 2.2\text{pF}$  always higher than  $1.5\text{k}\Omega$ .

Due to the large gain at start, the XTO is able to meet a very low start-up time. The oscillation start-up time can be estimated with the time constant  $\tau$ .

$$\tau = \frac{2}{4 \times \pi^2 \times f_m^2 \times C_m \times (\text{Re}(Z_{XTO\text{core}}) + R_m)}$$

After  $10\tau$  to  $20\tau$ , an amplitude detector detects the oscillation amplitude and sets XTO\_OK to High if the amplitude is large enough. This activates the CLK output if CLK\_ON and CLK\_EN in control register 3 are High (see [Table 9-12 on page 35](#)). Note that the necessary conditions of the DVCC voltage also have to be fulfilled (see [Figure 6-2 on page 24](#) and [Figure 7-1 on page 27](#)).

To save current in IDLE and Sleep mode, the load capacitors partially are switched off in this modes with  $S_1$  and  $S_2$  seen in [Figure 6-2 on page 24](#).

It is recommended to use a crystal with  $C_m = 3.0\text{fF}$  to  $7.0\text{fF}$ ,  $C_{LN} = 9\text{pF}$ ,  $R_m < 120\Omega$  and  $C_0 = 1.0\text{pF}$  to  $2.2\text{pF}$ .

Lower values of  $C_m$  can be used, this increases slightly the start-up time. Lower values of  $C_0$  or higher values of  $C_m$  (up to  $15\text{fF}$ ) can also be used, this has only little influence to pulling.

**Figure 6-2. XTO Block Diagram**

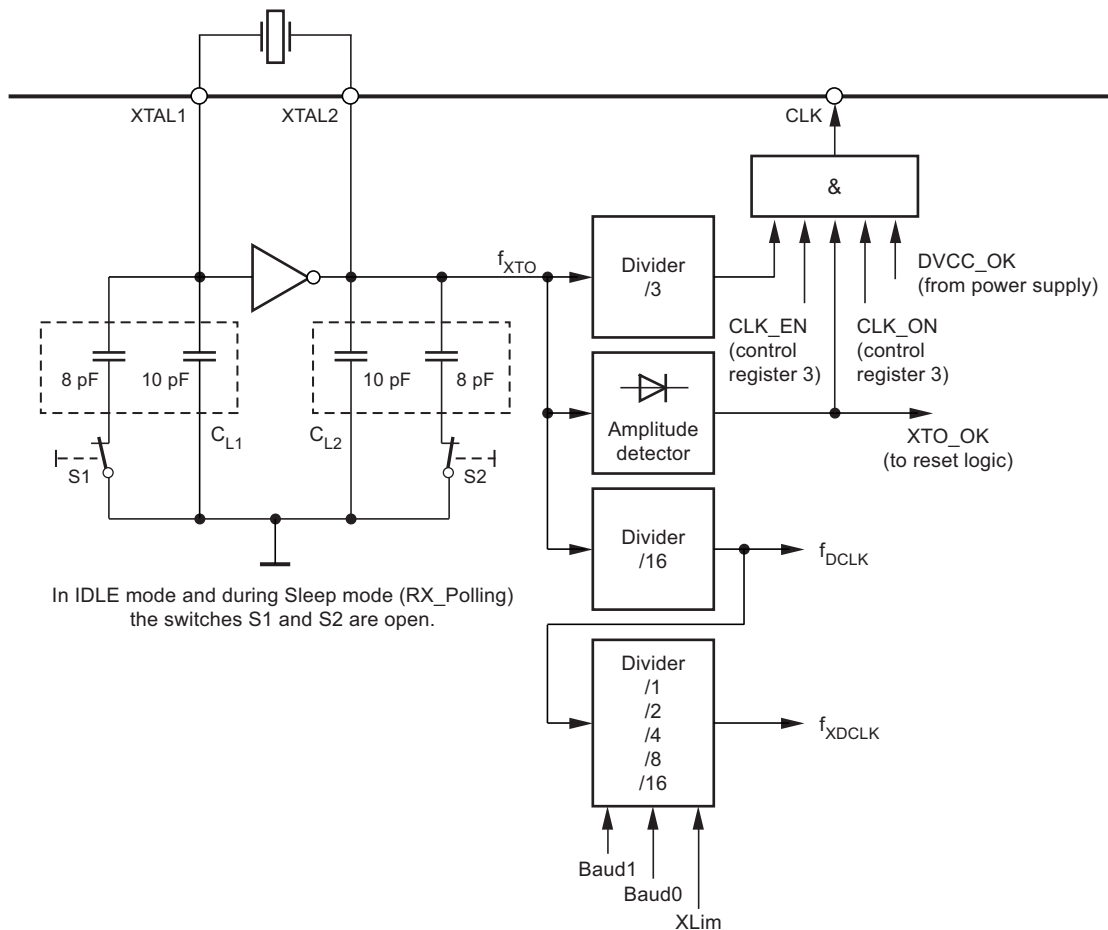

To find the right values used in the control registers 2 and 3 (see [Table 9-7 on page 34](#) and [Table 9-10 on page 35](#)) the relationship between  $f_{XTO}$  and the  $f_{RF}$  is shown in [Table 6-1](#). To determine the right content, the frequency at pin CLK, as well as the output frequency at RF\_OUT in ASK mode can be measured, than the FREQ value can be calculated according to [Table 6-1](#) so that  $f_{RF}$  is exactly the desired radio frequency.

**Table 6-1. Calculation of  $f_{RF}$**

Frequency (MHz)	Pin 6 433_N868	CREG1 Bit(4) FS	$f_{XTO}$ (MHz)	$f_{RF} = f_{TX\_ASK} = f_{RX}$	$f_{TX\_FSK\_L} = f_{TX\_FSK\_L(FD)}$	$f_{TX\_FSK\_H}$	$f_{TX\_FSK\_H(FD)}$	Frequency Resolution
315.0	AVCC	1	12.73193	$f_{XTO} \times \left( 24,5 + \frac{FREQ + 24,5}{16384} \right)$	$f_{RF} - 18.65\text{kHz}$	$f_{RF} + 18.65\text{ kHz}$	$f_{RF} + 208.23\text{kHz}$	777.1Hz
433.92	AVCC	0	13.25311	$f_{XTO} \times \left( 32,5 + \frac{FREQ + 24,5}{16384} \right)$	$f_{RF} - 19.41\text{kHz}$	$f_{RF} + 19.41\text{kHz}$	$f_{RF} + 203.74\text{kHz}$	808.9Hz

The variable FREQ depends on the bit PLL\_MODE in control register 1 and the parameter FREQ2 and FREQ3, which are defined by the bits FR0 to FR12 in control register 2 and 3 and is calculated as follows:

$$FREQ = FREQ2 + FREQ3$$

Care must be taken with the harmonics of the CLK output signal  $f_{CLK}$ , as well as to the harmonics produced by an microprocessor clocked with it, since these harmonics can disturb the reception of signals if they get to the RF input. In a single channel system the use of FREQ = 3803 to 4053 ensures that harmonics of this signal do not disturb the receive mode. In a multichannel system the CLK signal can either be not used or carefully layouted on the application PCB. The supply voltage of the microcontroller must also be carefully blocked in a multichannel system.

## 6.1 Pin CLK

Pin CLK is an output to clock a connected microcontroller. The clock frequency  $f_{CLK}$  is calculated as follows:

$$f_{CLK} = \frac{f_{XTO}}{3}$$

The signal at CLK output has a nominal 50% duty cycle.

If the bit CLK\_EN in control register 3 is set to 0, the clock is disabled permanently.

If the bit CLK\_EN is set to 1 and bit CLK\_ON (control register 3) is set to 0, the clock is disabled as well. If bit CLK\_ON is set to 1 and thus the clock is enabled if the Bit-check is ok (RX, RX Polling, FD mode (Slave)), an event on pin N\_PWR\_ON occurs or the bit Power\_On in the status register is 1.

**Figure 6-3. Clock Timing**

