



Chipsmall Limited consists of a professional team with an average of over 10 year of expertise in the distribution of electronic components. Based in Hongkong, we have already established firm and mutual-benefit business relationships with customers from,Europe,America and south Asia,supplying obsolete and hard-to-find components to meet their specific needs.

With the principle of “Quality Parts,Customers Priority,Honest Operation,and Considerate Service”,our business mainly focus on the distribution of electronic components. Line cards we deal with include Microchip,ALPS,ROHM,Xilinx,Pulse,ON,Everlight and Freescale. Main products comprise IC,Modules,Potentiometer,IC Socket,Relay,Connector.Our parts cover such applications as commercial,industrial, and automotives areas.

We are looking forward to setting up business relationship with you and hope to provide you with the best service and solution. Let us make a better world for our industry!



Contact us

Tel: +86-755-8981 8866 Fax: +86-755-8427 6832

Email & Skype: info@chipsmall.com Web: www.chipsmall.com

Address: A1208, Overseas Decoration Building, #122 Zhenhua RD., Futian, Shenzhen, China



Features

- Full-duplex Operation Mode without Duplex Frequency Offset to Prevent the Relay Attack against Passive Entry Go (PEG) Systems
- High FSK Sensitivity: -105.5 dBm at 20 Kbit/s/-109 dBm at 2.4 Kbit/s (433.92 MHz)
- High ASK Sensitivity: -111.5 dBm at 10 Kbit/s/-116 dBm at 2.4 Kbit/s (100% ASK, Carrier Level 433.92 MHz)
- Low Supply Current: 10.5 mA in RX and TX Mode (3V/TX with 5 dBm/433.92 MHz)
- Data Rate 1 to 20 Kbit/s Manchester FSK, 1 to 10 Kbit/s Manchester ASK
- ASK/FSK Receiver Uses a Low IF Architecture with High Selectivity, Blocking and Low Intermodulation (Typical 3 dB Blocking 55.5 dBC at ± 750 kHz/60.5 dBC at ± 1.5 MHz and 67 dBC at ± 10 MHz, System I1dBCP = -30 dBm/System IIP3 = -20 dBm)
- Wide Bandwidth AGC to Handle Large Outband Blockers above the System I1dBCP
- 226 kHz IF (Intermediate Frequency) with 30 dB Image Rejection and 220 kHz System Bandwidth to Support TPM Transmitters using ATA5756/ATA5757 Transmitters with Standard Crystals
- Transmitter Uses Closed Loop FSK Modulation with Fractional-N Synthesizer with High PLL Bandwidth and an Excellent Isolation between PLL and PA
- Tolerances of XTAL Compensated by Fractional-N Synthesizer with 800 Hz RF Resolution
- Integrated RX/TX-Switch, Single-ended RF Input and Output
- RSSI (Received Signal Strength Indicator)
- Communication to Microcontroller with SPI Interface Working at 500 kBit/s Maximum
- Configurable Self Polling and RX/TX Protocol Handling with FIFO-RAM Buffering of Received and Transmitted Data
- 1 Push Button Input and 1 Wake-up Input are Active in Power-down Mode
- Integrated XTAL Capacitors
- PA Efficiency: up to 38% (433.92 MHz/10 dBm/3V)
- Low In-band Sensitivity Change of Typically ± 2.0 dB within ± 75 kHz Center Frequency Change in the Complete Temperature and Supply Voltage Range
- Fully Integrated PLL with Low Phase Noise VCO, PLL Loop Filter and full support of multi-channel operation with arbitrary Channel distance due to Fractional-N Synthesizer
- Sophisticated Threshold Control and Quasi-peak Detector Circuit in the Data Slicer
- 433.92 MHz, 868.3 MHz and 315 MHz without External VCO and PLL Components
- Efficient XTO Start-up Circuit (> -1.5 k Ω Worst Case Start Impedance)
- Changing of Modulation Type ASK/FSK and Data Rate without Component Changes to Allow Different Modulation Schemes in TPM and RKE
- Minimal External Circuitry Requirements for Complete System Solution
- Adjustable Output Power: 0 to 10 dBm Adjusted and Stabilized with External Resistor, Programmable Output Power with 0.5dB Steps with Internal Resistor
- Clock and Interrupt Generation for Microcontroller
- ESD Protection at all Pins (± 2.5 kV HBM, ± 200 V MM, ± 500 V FCDM)
- Supply Voltage Range: 2.15V to 3.6V or 4.4V to 5.25V
- Typical Power-down Current < 10 nA
- Temperature Range: -40°C to +105°C
- Small 7 mm \times 7 mm QFN48 Package



UHF ASK/FSK Transceiver

ATA5823
ATA5824





Applications

- **Automotive Keyless Entry and Passive Entry Go (Handsfree Car Access)**
- **Tire Pressure Monitoring Systems**
- **Remote Control Systems**
- **Alarm and Telemetering Systems**
- **Energy Metering**
- **Home Automation**

Benefits

- **No SAW Device Needed in Key Fob Designs to Meet Automotive Specifications**
- **Low System Cost Due to Very High System Integration Level**
- **Only One Crystal Needed in System**
- **Less Demanding Specification for the Microcontroller Due to Handling of Power-down Mode, Delivering of Clock and Complete Handling of Receive/Transmit Protocol and Polling**
- **Single-ended Design with High Isolation of PLL/VCO from PA and the Power Supply Allows a Loop Antenna in the Key Fob to Surround the Whole Application**
- **Prevention against Relay Attack with Full-duplex Operation Mode**
- **Integration of Tire Pressure Monitoring, Passive Entry and Remote Keyless Entry**

1. General Description

The ATA5823/ATA5824 is a highly integrated UHF ASK/FSK multi-channel half-duplex and full-duplex transceiver with low power consumption supplied in a small 7 mm × 7 mm QFN48 package. The receive part is built as a fully integrated low-IF receiver, whereas direct PLL modulation with the fractional-N synthesizer is used for FSK transmission and switching of the power amplifier for ASK transmission. The additional full-duplex mode makes relay attacks much more difficult, since the attacker has to receive and transmit signals on the same frequency at the same time.

The device supports data rates of 1 Kbit/s to 20 Kbit/s (FSK) and 1 Kbit/s to 10 Kbit/s (ASK) in Manchester, Bi-phase and other codes in transparent mode. The ATA5824 can be used in the 433 MHz to 435 MHz band and the 867 MHz to 870 MHz band, the ATA5823 in the 313 MHz to 316 MHz band. The very high system integration level results in few numbers of external components needed.

Due to its blocking and selectivity performance, together with a typical narrow-band key-fob loop antenna with 15 dB to 20 dB loss, a bulky blocking SAW is not needed in the key fob application. Additionally, the building blocks needed for a typical RKE and access control system on both sides, the base and the mobile stations, are fully integrated.

Its digital control logic with self polling and protocol generation provides a fast challenge response system without using a high-performance microcontroller. Therefore, the ATA5823/ATA5824 contains a FIFO buffer RAM and can compose and receive the physical messages themselves. This provides more time for the microcontroller to carry out other functions such as calculating crypto algorithms, composing the logical messages and controlling other devices. Due to that, a standard 4-/8-bit microcontroller without special periphery and clocked with the delivered CLK output of about 4.5 MHz is sufficient to control the communication link. This is especially valid for passive entry go and access control systems, where within less than 100 ms several communication responses with arbitration of the communication partner have to be handled. It is hence possible to design bi-directional RKE and passive entry go systems with a fast challenge response crypto function and prevention against relay attacks.

Figure 1-1. System Block Diagram

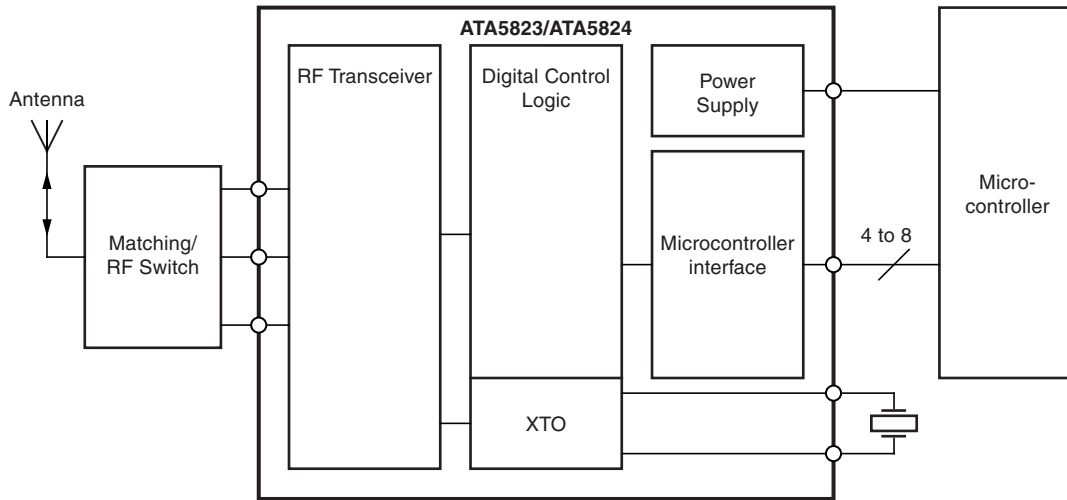

2. Pin Configuration

Figure 2-1. Pinning QFN48

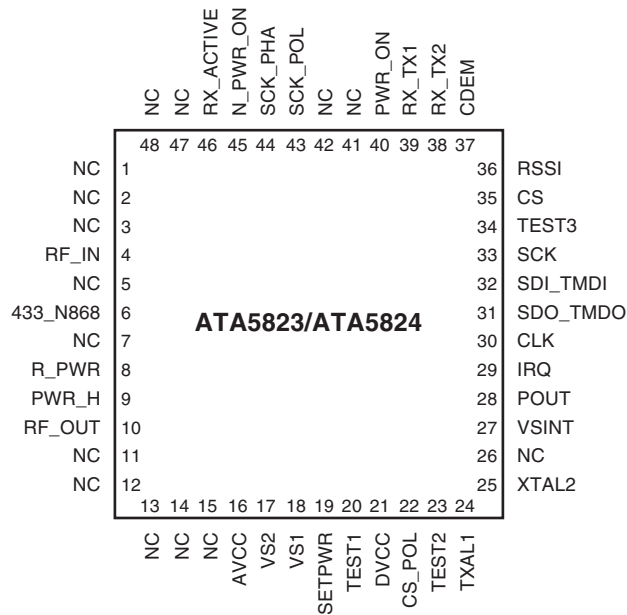

Table 2-1. Pin Description

Pin	Symbol	Function
1	NC	Not connected
2	NC	Not connected
3	NC	Not connected
4	RF_IN	RF input
5	NC	Not connected
6	433_N868	Selects RF input/output frequency range
7	NC	Not connected
8	R_PWR	Resistor to adjust output power
9	PWR_H	Pin to select output power
10	RF_OUT	RF output
11	NC	Not connected
12	NC	Not connected
13	NC	Not connected
14	NC	Not connected
15	NC	Not connected
16	AVCC	Blocking of the analog voltage supply
17	VS2	Power supply input for voltage range 4.4V to 5.6V
18	VS1	Power supply input for voltage range 2.15V to 3.6V
19	SETPWR	Internal Programmable Resistor to adjust output power
20	TEST1	Test input, at GND during operation
21	DVCC	Blocking of the digital voltage supply
22	CS_POL	Select polarity of pin CS
23	TEST2	Test input, at GND during operation
24	XTAL1	Reference crystal
25	XTAL2	Reference crystal
26	NC	Not connected
27	VSINT	Microcontroller interface supply voltage
28	POUT	Programmable output
29	IRQ	Interrupt request
30	CLK	Clock output to connect a microcontroller
31	SDO_TMDO	Serial data out/transparent mode data out
32	SDI_TMDI	Serial data in/transparent mode data in
33	SCK	Serial clock
34	TEST3	Test output open during operation
35	CS	Chip select for serial interface
36	RSSI	Output of the RSSI amplifier
37	CDEM	Capacitor to adjust the lower cut-off frequency data filter
38	RX_TX2	Has to be connected GND
39	RX_TX1	Switch pin to decouple LNA in TX mode (RKE mode)
40	PWR_ON	Input to switch on the system (active high)
41	NC	Not connected

Table 2-1. Pin Description (Continued)

Pin	Symbol	Function
42	NC	Not connected
43	SCK_POL	Polarity of the serial clock
44	SCK_PHA	Phase of the serial clock
45	N_PWR_ON	Keyboard input (can also be used to switch on the system, active low)
46	RX_ACTIVE	Indicates RX operation mode
47	NC	Not connected
48	NC	Not connected
	GND	Ground/Backplane (exposed die pad)

Figure 2-2. Block Diagram

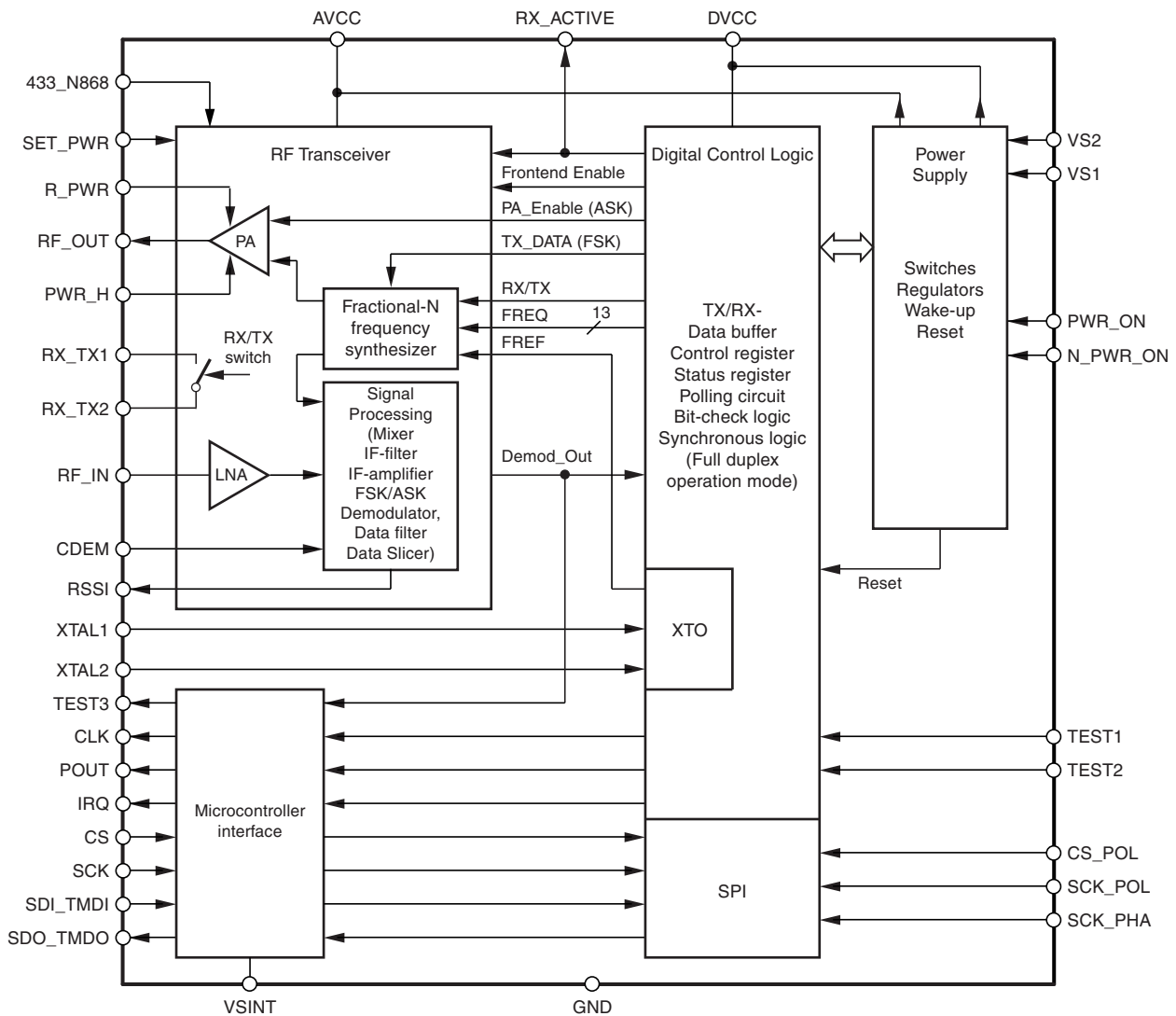

3. Typical Key Fob Application for Bi-directional RKE

Figure 3-1. Typical Key Fob Application for Bi-directional RKE with 5 dBm TX Power, 433.92 MHz

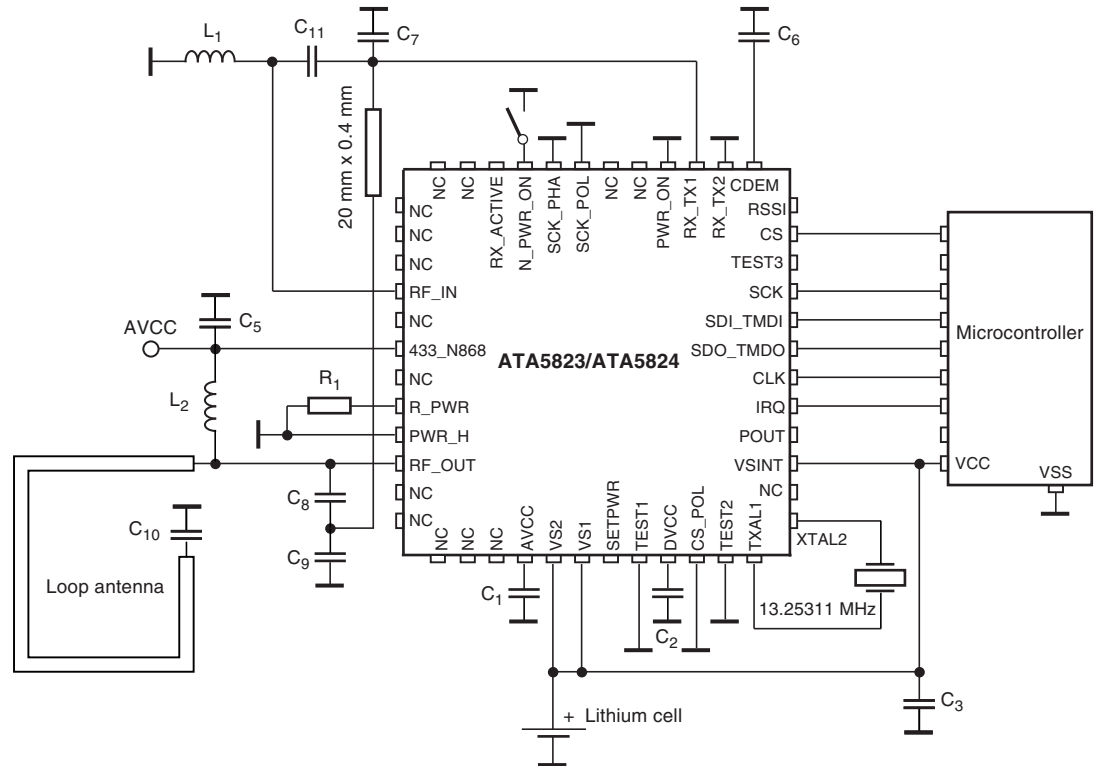

Figure 3-1 shows a typical 433.92 MHz RKE key fob application. The external components are 10 capacitors, 1 resistor, 2 inductors and a crystal. C_1 to C_3 are 68 nF voltage supply blocking capacitors. C_5 is a 10 nF supply blocking capacitor. C_6 is a 15 nF fixed capacitor used for the internal quasi-peak detector and for the high-pass frequency of the data filter. C_7 to C_{11} are RF matching capacitors in the range of 1 pF to 33 pF. L_1 is a matching inductor of about 5.6 nH to 56 nH. L_2 is a feed inductor of about 120 nH. A load capacitor of 9 pF for the crystal is integrated. R_1 is typically 22 k Ω and sets the output power to about 5.5 dBm. The loop antenna's quality factor is somewhat reduced by this application due to the quality factor of L_2 and the RX/TX switch. On the other hand, this lower quality factor is necessary to have a robust design with a bandwidth that is wide enough for production tolerances. Due to the single-ended and ground-referenced design, the loop antenna can be a free-form wire around the application as it is usually employed in RKE unidirectional systems. The ATA5823/ATA5824 provides sufficient isolation and robust pulling behavior of internal circuits from the supply voltage as well as an integrated VCO inductor to allow this. Since the efficiency of a loop antenna is proportional to the square of the surrounded area, it is beneficial to have a large loop around the application board with a lower quality factor to relax the tolerance specification of the RF matching components and to get a high antenna efficiency in spite of their lower quality factor.

4. Typical Car Application for Bi-directional RKE

Figure 4-1. Typical Car Application for Bi-directional RKE with 10 dBm TX Power, 433.92 MHz

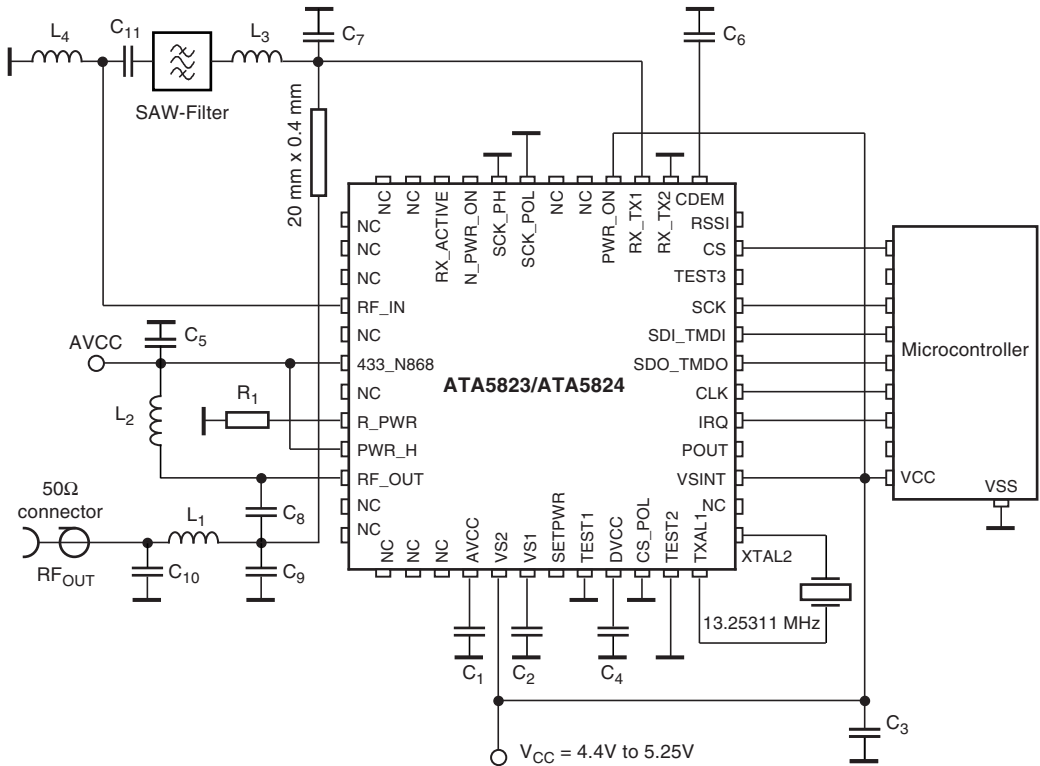

Figure 4-1 shows a typical 433.92 MHz $V_{CC} = 4.4\text{V}$ to 5.25V RKE car application. The external components are 11 capacitors, 1 resistor, 4 inductors, a SAW filter and a crystal. C_1 , C_3 and C_4 are 68 nF voltage supply blocking capacitors. C_2 is a 2.2 μF supply blocking capacitor for the internal voltage regulator. C_5 is a 10 nF supply blocking capacitor. C_6 is a 15 nF fixed capacitor used for the internal quasi-peak detector and for the high-pass frequency of the data filter. C_7 to C_{11} are RF matching capacitors in the range of 1 pF to 33 pF. L_2 to L_4 are matching inductors of about 5.6 nH to 56 nH. A load capacitor for the crystal of 9 pF is integrated. R_1 is typically 22 k Ω and sets the output power at RF_{OUT} to about 10 dBm. Since a quarter wave or PCB antenna, which has high efficiency and wideband operation, is typically used here, it is recommended to use a SAW filter to achieve high sensitivity in case of powerful out-of-band blockers. L_1 , C_{10} and C_9 together form a low-pass filter, which is needed to filter out the harmonics in the transmitted signal to meet regulations.

5. Typical Key Fob Application for Full-duplex PEG

Figure 5-1. Typical Key Fob Application for Full-duplex PEG, 433.92 MHz

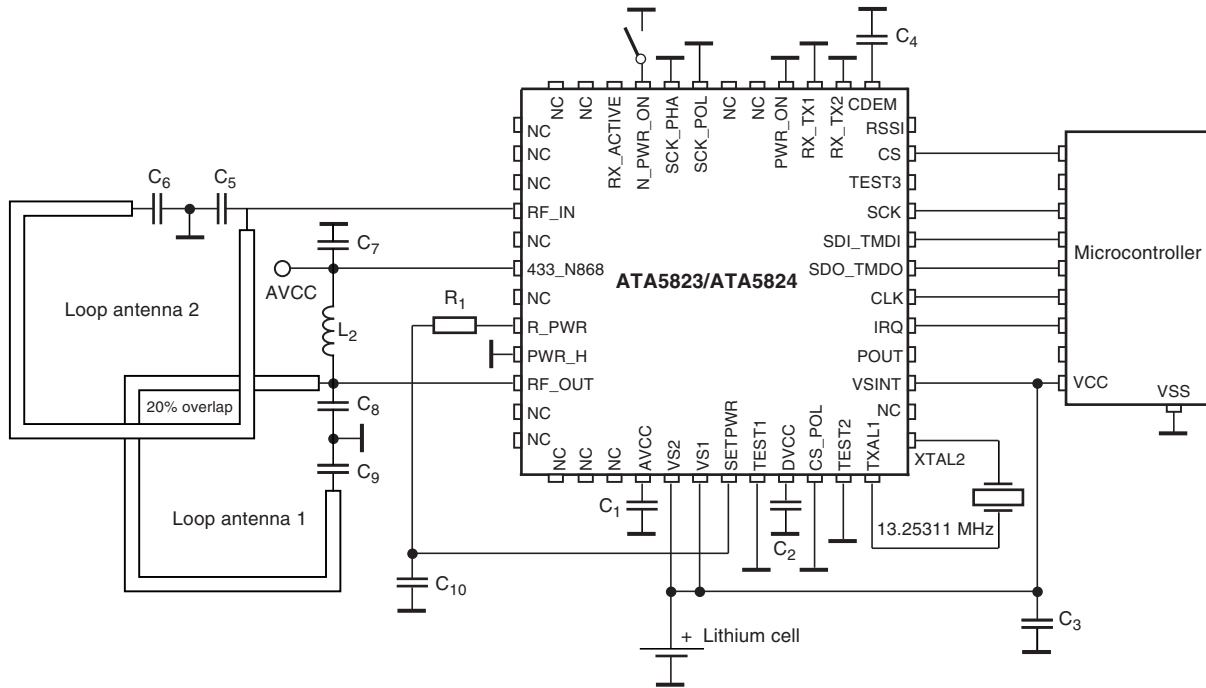

Figure 5-1 shows a typical 433.92 MHz PEG key fob application. The external components are 10 capacitors, 1 resistor, 1 inductor and a crystal. C_1 to C_3 are 68 nF voltage supply blocking capacitors. C_7 is a 10 nF supply blocking capacitor. C_4 is a 15 nF fixed capacitor used for the internal quasi-peak detector and for the high-pass frequency of the data filter. C_5 , C_6 , C_8 and C_9 are RF matching capacitors in the range of 1 pF to 33 pF. L_2 is a feed inductor of about 120 nH. C_{10} is a 10 nF capacitor which is necessary to prevent that signals couple into the pin R_PWR, causing amplitude modulation of the output power and a spurious rise of the transmitted signal. R_1 and C_{10} should be placed close to the R_PWR pin. A load capacitor of 9 pF for the crystal is integrated. R_1 is typically 22 k Ω and SETPWR is programmed to get an output power of -7 dBm in full-duplex mode and 5 dBm in half-duplex mode. The quality factor of the loop antenna 1 is only reduced by the quality factor of L_2 , the tolerances of C_9 and C_8 are thus important. The quality factor of the loop antenna 2 is reduced to half due to the loading with the input impedance of RF_IN. With well designed loop antennas and the correct degree of overlapping, the isolation between RF_OUT and RF_IN is about 28 dB and the coupled output power from RF_OUT to RF_IN is about -35 dBm. The decoupling of two loop antennas situated close to each other is due to the effect that the magnetic flux from the part of loop antenna 1 that does not overlap and that of the overlapping part has an opposite direction. Depending on the relative position between the two antennas, a decoupling of 28 dB is achievable. Due to additional capacitive coupling between the loops the position of the components C_5 , C_6 and C_8 , C_9 are also important. The receive Sensitivity in full-duplex mode is reduced from -106 dBm without coupled RF-Power at RF_IN to -96 dBm with -35 dBm coupled RF power at RF_IN.

6. Typical Car Application for Full-duplex PEG

Figure 6-1. Typical Car Application for Full-duplex PEG, 433.92 MHz

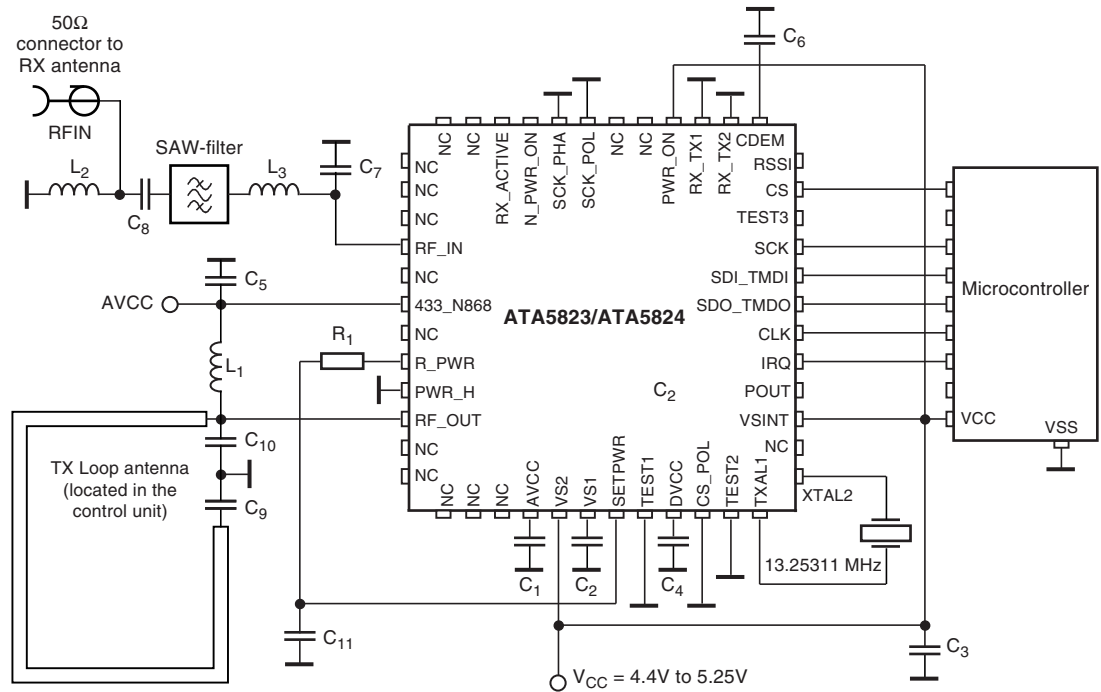

Figure 6-1 shows a typical 433.92 MHz $V_{CC} = 4.4V$ to $5.25V$ PEG car application. The external components are 11 capacitors, 1 resistor, 3 inductors, a SAW Filter and a crystal. C_1 , C_3 and C_4 are 68 nF voltage supply blocking capacitors. C_2 is a 2.2 μF supply blocking capacitors for the internal voltage regulator. C_5 is a 10 nF supply blocking capacitor. C_6 is a 15 nF fixed capacitor used for the internal quasi-peak detector and for the high-pass frequency of the data filter. C_7 to C_{10} are RF matching capacitors in the range of 1 pF to 33 pF. L_1 is a feed inductor of about 120 nH, L_2 and L_3 are matching inductors to match the RX-antenna to the SAW and the SAW to RF_IN. A load capacitor of 9 pF for the crystal is integrated. C_{11} is a 10 nF capacitor which is necessary to prevent that signals couple into the pin R_PWR, causing amplitude modulation of the output power and a spurious rise of the transmitted signal. R_1 and C_{11} should be placed close to the R_PWR pin. R_1 is typically 22 k Ω and SETPWR is programmed to get an output power of 0 dBm in full-duplex mode and 5 dBm in half-duplex mode. The quality factor of the TX-loop antenna is only reduced by the quality factor of L_1 , the tolerances of C_9 and C_{10} are thus important. Since the 2 Antennas are located at different places the isolation between RF_OUT and RF_IN is about 45 dB and the coupled output power from RF_OUT to RF_IN is about -45 dBm. The receive Sensitivity in full-duplex mode is reduced from -106 dBm without coupled RF power at RF_IN to -102 dBm with -45 dBm coupled RF power at RF_IN. The use of SAW filters in the full-duplex system is unsuitable due to the high group delay which desensitize the receiver.

7. RF Transceiver in Half-duplex Mode

According to [Figure 2-2 on page 5](#), the RF transceiver consists of an LNA (Low-Noise Amplifier), PA (Power Amplifier), RX/TX switch, fractional-N frequency synthesizer and the signal processing part with mixer, IF filter, IF amplifier with analog RSSI, FSK/ASK demodulator, data filter and data slicer.

In receive mode the LNA pre-amplifies the received signal which is converted down to 226 kHz intermediate frequency (IF), filtered and amplified before it is fed into an FSK/ASK demodulator, data filter and data slicer. The RSSI (Received Signal Strength Indicator) signal and the raw digital output signal of the demodulator are available at the pins RSSI and on TEST3 (open drain output). The demodulated data signal Demod_Out is fed into the digital control logic where it is evaluated and buffered as described in section [“Digital Control Logic” on page 35](#).

In transmit mode the fractional-N frequency synthesizer generates the TX frequency which is fed into the PA. In ASK mode the PA is modulated by the signal PA_Enable. In FSK mode the PA is enabled and the signal TX_DATA (FSK) modulates the fractional-N frequency synthesizer. The frequency deviation is digitally controlled and internally fixed to about ± 19.5 kHz (see [Table 9-1 on page 30](#) for exact values). The transmit data can also be buffered as described in section [“Digital Control Logic” on page 35](#). A lock detector within the synthesizer ensures that the transmission will only start if the synthesizer is locked.

In half-duplex mode the RX/TX switch can be used to combine the LNA input and the PA output to a single antenna with a minimum of losses. In full-duplex mode more isolation between receive and transmit antenna is needed, therefore two antennas have to be used.

Transparent modes without buffering of RX and TX data are also available to allow protocols and coding schemes other than the internal supported Manchester encoding, like PWM and pulse position coding.

7.1 Low-IF Receiver

The receive path consists of a fully integrated low-IF receiver. It fulfills the sensitivity, blocking, selectivity, supply voltage and supply current specification needed to manufacture an automotive key fob for RKE and PEG systems without the use of a SAW blocking filter (see [Figure 3-1 on page 6](#) and [Figure 5-1 on page 8](#)). The receiver can be connected to the roof antenna in the car when using an additional blocking SAW front-end filter as shown in [Figure 4-1 on page 7](#).

At 433.92 MHz the receiver has a typical system noise figure of 6.5 dB, a system I1dBCP of -30 dBm and a system IIP3 of -20 dBm. The signal path is linear for disturbers up to the I1dBCP and there is hence no AGC or switching of the LNA needed to achieve a better blocking performance. This receiver uses an IF of about 226 kHz (see table “Electrical Characteristics” number 2.10 for exact values), the typical image rejection is 30 dB and the typical 3 dB system bandwidth is 220 kHz ($f_{IF} = 226$ kHz ± 110 kHz, $f_{lo_IF} = 116$ kHz and $f_{hi_IF} = 336$ kHz). The demodulator needs a signal to noise ratio of 8 dB for 20 Kbit/s Manchester with ± 19.5 kHz frequency deviation in FSK mode, thus, the resulting sensitivity at 433.92 MHz is typically -105.5 dBm.

Due to the low phase noise and spurious of the synthesizer in receive mode⁽¹⁾ together with the eighth order integrated IF filter the receiver has a better selectivity and blocking performance than more complex double superhet receivers, without using external components and without numerous spurious receiving frequencies.

Note: 1. -120 dBC/Hz at ± 1 MHz and -72 dBC at $\pm f_{XTO}$ at 433.92 MHz

A low-IF architecture is also less sensitive to second-order intermodulation (IIP2) than direct conversion receivers where every pulse or amplitude modulated signal (especially the signals from TDMA systems like GSM) demodulates to the receiving signal band at second-order non-linearities.

7.2 Input Matching at RF_IN

The measured input impedances as well as the values of a parallel equivalent circuit of these impedances can be seen in [Table 7-1](#). The highest sensitivity is achieved with power matching of these impedances to the source impedance of 50Ω.

Table 7-1. Measured Input Impedances of the RF_IN Pin

f_{RF}/MHz	$Z_{in}(\text{RF_IN})$	R_{in_p}/C_{in_p}
315	$(44-j233)\Omega$	$1278\Omega/2.1\text{ pF}$
433.92	$(32-j169)\Omega$	$925\Omega/2.1\text{ pF}$
868.3	$(21-j78)\Omega$	$311\Omega/2.2\text{ pF}$

The matching of the LNA Input to 50Ω was done with the circuit according to [Figure 7-1](#) and with the values of the matching elements given in [Table 7-2](#). The reflection coefficients were always $\leq -10\text{ dB}$. Note that value changes of C_1 and L_1 may be necessary to compensate individual board layout parasitics. The measured typical FSK and ASK Manchester code sensitivities with a Bit Error Rate (BER) of 10^{-3} are shown in [Table 7-3 on page 12](#) and [Table 7-4 on page 12](#). These measurements were done with multilayer inductors having quality factors according to [Table 7-2](#), resulting in estimated matching losses of 0.8 dB at 315 MHz, 0.8 dB at 433.92 MHz and 0.7 dB at 868.3 MHz. These losses can be estimated when calculating the parallel equivalent resistance of the inductor with $R_{loss} = 2 \times \pi \times f \times L \times Q_L$ and the matching loss with $10 \log(1 + R_{in_p}/R_{loss})$.

With an ideal inductor, for example, the sensitivity at 433.92 MHz/FSK/20 Kbit/s/ $\pm 19.5\text{ kHz}$ /Manchester can be improved from -105.5 dBm to -106.7 dBm . The sensitivity also depends on the values in the registers of the control logic which examines the incoming data stream. The examination limits must be programmed in control registers 5 and 6. The measurements in [Table 7-3](#) and [Table 7-4 on page 12](#) are based on the values of registers 5 and 6 according to [Table 14-3 on page 60](#).

Figure 7-1. Input Matching to 50Ω

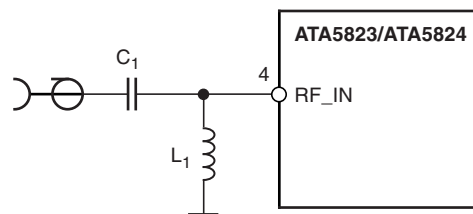

Table 7-2. Input Matching to 50Ω

f_{RF}/MHz	C_1/pF	L_1/nH	Q_{L1}
315	2.4	47	65
433.92	1.8	27	67
868.3	1.2	6.8	50

Table 7-3. Measured Typical Sensitivity 433.92 MHz, FSK, ± 19.5 kHz, Manchester, BER = 10^{-3}

RF Frequency	BR_Range_0 1.0 Kbit/s	BR_Range_0 2.4 Kbit/s	BR_Range_1 5.0 Kbit/s	BR_Range_2 10 Kbit/s	BR_Range_3 20 Kbit/s
315 MHz	-109.5 dBm	-110.0 dBm	-109.0 dBm	-107.5 dBm	-106.5 dBm
433.92 MHz	-108.5 dBm	-109.0 dBm	-108.0 dBm	-106.5 dBm	-105.5 dBm
868.3 MHz	-105.5 dBm	-106.5 dBm	-105.5 dBm	-103.5 dBm	-103.0 dBm

Table 7-4. Measured Typical Sensitivity 433.92 MHz, 100% ASK, Manchester, BER = 10^{-3}

RF Frequency	BR_Range_0 1.0 Kbit/s	BR_Range_0 2.4 Kbit/s	BR_Range_1 5.0 Kbit/s	BR_Range_2 10 Kbit/s
315 MHz	-117.0 dBm	-117.0 dBm	-114.5 dBm	-112.5 dBm
433.92 MHz	-116.0 dBm	-116.0 dBm	-113.5 dBm	-111.5 dBm
868.3 MHz	-113.0 dBm	-113.0 dBm	-111.5 dBm	-109.0 dBm

7.3 Sensitivity versus Supply Voltage, Temperature and Frequency Offset

To calculate the behavior of a transmission system it is important to know the reduction of the sensitivity due to several influences. The most important are frequency offset due to crystal oscillator (XTO) and crystal frequency (XTAL) errors, temperature and supply voltage dependency of the noise figure and IF filter bandwidth of the receiver. Figure 7-2 shows the typical sensitivity at 433.92 MHz/FSK/20 Kbit/s/ ± 19.5 kHz/Manchester versus the frequency offset between transmitter and receiver at $T_{amb} = -40^\circ\text{C}$, $+25^\circ\text{C}$ and $+105^\circ\text{C}$ and supply voltage $V_S = V_{S1} = V_{S2} = 2.15\text{V}$, 3.0V and 3.6V .

Figure 7-2. Measured Sensitivity 433.92 MHz/FSK/20 Kbit/s/ ± 19.5 kHz/Manchester versus Frequency Offset, Temperature and Supply Voltage

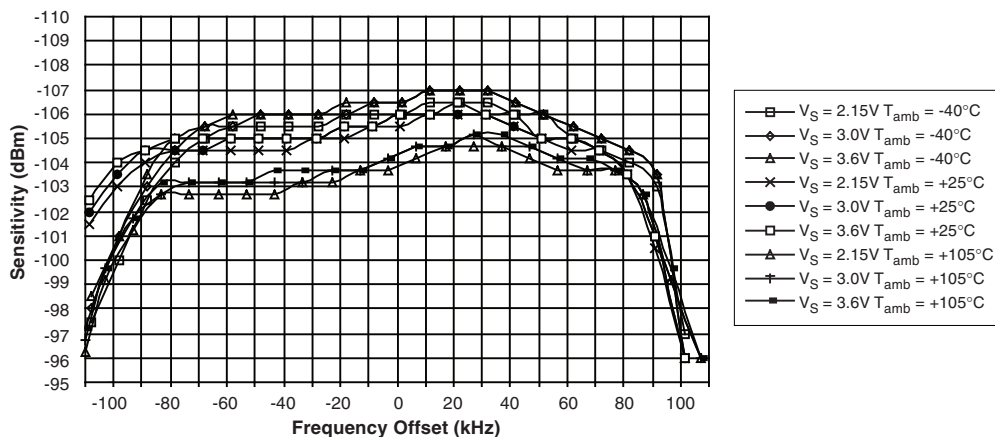

As can be seen in [Figure 7-2 on page 12](#) the supply voltage has almost no influence on the sensitivity. The temperature has an influence of about +1.5/-0.7 dB and a frequency offset of ± 85 kHz also influences by about ± 1 dB. All these influences, combined with the sensitivity of a typical IC (-105.5dBm), are then within a range of -102.5 dBm and -107 dBm overtemperature, supply voltage and frequency offset. The integrated IF filter has an additional production tolerance of ± 10 kHz, hence, a frequency offset between the receiver and the transmitter of ± 75 kHz can be accepted for XTAL and XTO tolerances.

Note: For the demodulator used in the ATA5823/ATA5824, the tolerable frequency offset does not change with the data frequency, hence, the value of ± 75 kHz is valid for 1 Kbit/s to 20 Kbit/s.

This small sensitivity change over supply voltage, frequency offset and temperature is very unusual in such a receiver. It is achieved by an internal, very fast and automatic frequency correction in the FSK demodulator after the IF filter, which leads to a higher system margin. This frequency correction tracks the input frequency very quickly, if however, the input frequency makes a larger step (e.g., if the system changes between different communication partners), the receiver has to be restarted. This can be done by switching back to IDLE mode and then again to RX mode. For that purpose, an automatic mode is also available. This automatic mode switches to IDLE mode and back into RX mode every time a bit error occurs (see section [“Digital Control Logic” on page 35](#)).

7.4 Frequency Accuracy of the Crystals in Bi-directional RKE/PEG

The XTO is an amplitude regulated Pierce type oscillator with integrated load capacitors. The initial tolerances (due to the frequency tolerance of the XTAL, the integrated capacitors on XTAL1, XTAL2 and the XTO's initial transconductance gm) can be compensated to a value within ± 0.5 ppm by measuring the CLK output frequency and tuning of f_{RF} by programming the control registers 2 and 3 (see [Table 12-7 on page 38](#) and [Table 12-10 on page 39](#)). The XTO then has a remaining influence of less than ± 2 ppm overtemperature and supply voltage due to the band-gap controlled gm of the XTO. Thus only 2.5 ppm add to the frequency stability of the used crystals overtemperature and aging.

The needed frequency stability of the used crystals **overtemperature and aging** is hence ± 75 kHz/433.92 MHz - $2 \times \pm 2.5$ ppm = ± 167.84 ppm for 433.92 MHz and ± 75 kHz/868.3 MHz - $2 \times \pm 2.5$ ppm = ± 81.4 ppm for 868.3 MHz. Thus, the used crystals in receiver and transmitter each need to be better than ± 83.9 ppm for 433.92 MHz and ± 40.7 ppm for 868.3 MHz.

7.5 Frequency Accuracy of the Crystals in a Combined RKE/PEG and TPM System

In a tire pressure measurement system working at 433.92 MHz and using a TPM transmitter ATA5757 and a transceiver ATA5824 as a receiver, the higher frequency tolerances and the tolerance of the frequency deviation of this transmitter has to be considered.

In the TPM transmitter the crystal has an frequency error overtemperature -40°C to +125°C, aging and tolerance of ± 80 ppm (± 34.7 kHz at 433.92 MHz). The tolerances of the XTO, the capacitors used for FSK-Modulation and the stray capacitors, causing an additional frequency error of ± 30 ppm (± 13 kHz at 433.92 MHz). The frequency deviation of such a transmitter varies between ± 16 kHz and ± 24 kHz, since a higher frequency deviation is equivalent to an frequency error, this has to be considered as an additional ± 24 kHz - ± 19.5 kHz = ± 4.5 kHz frequency tolerance. All tolerances added, these transmitters have a worst case frequency offset of ± 52.2 kHz.

For the transceiver in the car a tolerance of $\pm 75 \text{ kHz} - \pm 52.2 \text{ kHz} = \pm 22.8 \text{ kHz}$ ($\pm 52.5 \text{ ppm}$) remains. The needed frequency stability of the used crystals **overtemperature and aging** is $\pm 52.5 \text{ ppm} - \pm 2.5 \text{ ppm} = \pm 50 \text{ ppm}$. The aging of such a crystal is $\pm 10 \text{ ppm}$ leaving reasonable $\pm 40 \text{ ppm}$ for the temperature dependency of the crystal frequency in the car.

Since the transceiver in the car is able to receive these TPM transmitter signals with high frequency offsets, the component specification in the key can be largely relaxed.

This system calculation is based on worst case tolerances of all the components, this leads in practice to a system with margin.

For a 315 MHz TPM system using a TPM transmitter ATA5756 and a transceiver ATA5823 as receiver the same calculation must be done, but since the RF frequency is lower, every ppm of crystal tolerances results in less frequency offset and either the system can have higher tolerances or a higher margin there.

For 868 MHz it is not possible to use the transceiver ATA5824 in a combined RKE/PEG and TPM system since all the tolerances double because of the higher RF frequency.

7.6 RX Supply Current versus Temperature and Supply Voltage

Table 7-5 shows the typical supply current at 433.92 MHz of the transceiver in RX mode versus supply voltage and temperature with $V_S = V_{S1} = V_{S2}$. As can be seen the supply current at $V_S = 2.15\text{V}$ and $T_{\text{amb}} = -40^\circ\text{C}$ is less than at $V_S = 3\text{V}/T_{\text{amb}} = 25^\circ$ which helps to enlarge the battery lifetime within a key fob application because this is also the operation point where a lithium cell has the worst performance. The typical supply current at 315 MHz or 868.3 MHz in RX mode is about the same as for 433.92 MHz.

Table 7-5. Measured 433.92 MHz Receive Supply Current in FSK mode

$V_S = V_{S1} = V_{S2}$	2.15V	3.0V	3.6V
$T_{\text{amb}} = -40^\circ\text{C}$	8.2 mA	8.8 mA	9.2 mA
$T_{\text{amb}} = 25^\circ\text{C}$	9.7 mA	10.3 mA	10.8 mA
$T_{\text{amb}} = 105^\circ\text{C}$	11.2 mA	11.9 mA	12.4 mA

7.7 Blocking, Selectivity

As can be seen in Figure 7-3, Figure 7-4 and Figure 7-5 on page 15, the receiver can receive signals 3 dB higher than the sensitivity level in presence of large blockers of $-44.5 \text{ dBm}/-36.0 \text{ dBm}$ with small frequency offsets of $\pm 1/\pm 10 \text{ MHz}$.

Figure 7-3 and Figure 7-4 on page 15 shows the close-in and narrow-band blocking and Figure 7-5 on page 15 the wide-band blocking characteristic. The measurements were done with a useful signal of 433.92 MHz/FSK/20 Kbit/s/ $\pm 19.5 \text{ kHz}$ /Manchester with a level of $-105.5 \text{ dBm} + 3 \text{ dB} = -102.5 \text{ dBm}$ which is 3 dB above the sensitivity level. The figures show by how much a continuous wave signal can be larger than -102.5 dBm until the BER is higher than 10^{-3} . The measurements were done at the 50Ω input according to Figure 7-1 on page 11. At 1 MHz, for example, the blocker can be 58 dBC higher than -102.5 dBm which is $-102.5 \text{ dBm} + 58 \text{ dBC} = -44.5 \text{ dBm}$. These blocking figures, together with the good intermodulation performance, avoid the additional need of a SAW filter in the key fob application.

Figure 7-3. Close In 3 dB Blocking Characteristic and Image Response at 433.92 MHz

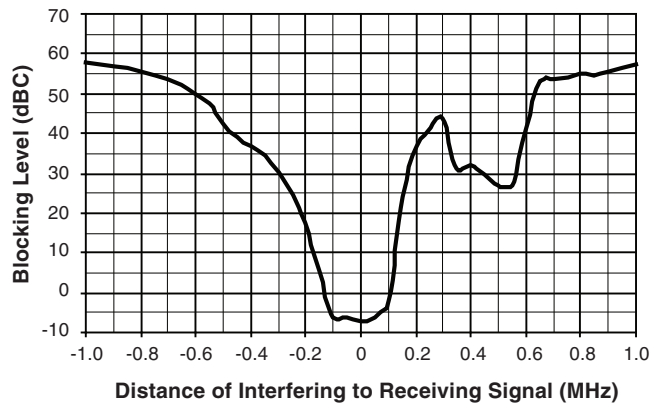

Figure 7-4. Narrow Band 3 dB Blocking Characteristic at 433.92 MHz

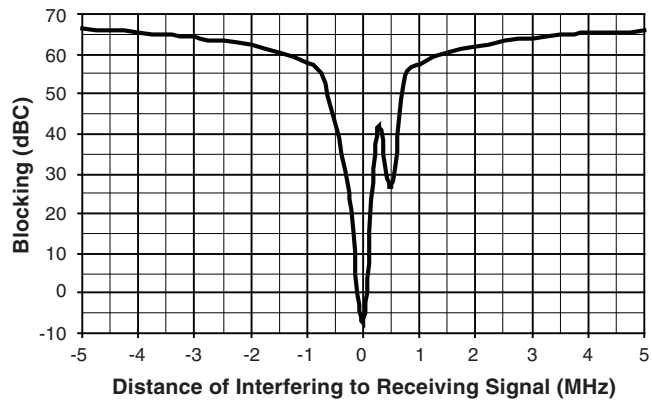

Figure 7-5. Wide Band 3 dB Blocking Characteristic at 433.92 MHz

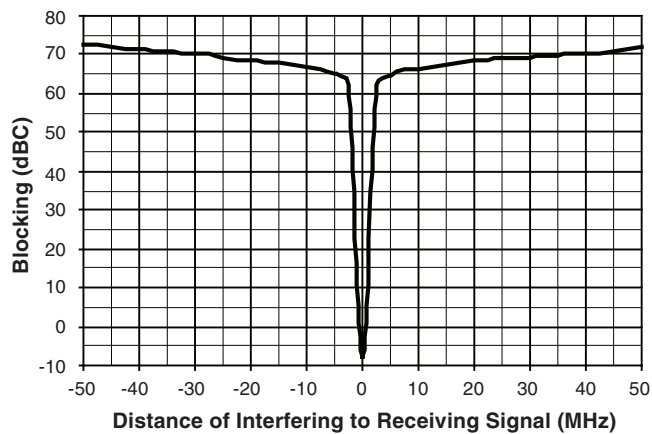

Table 7-6 shows the blocking performance measured relative to -102.5 dBm for some frequencies. Note that sometimes the blocking is measured relative to the sensitivity level -105.5 dBm (denoted dBS) instead of the carrier -102.5 dBm (denoted dBC).

Table 7-6. Blocking 3 dB Above Sensitivity Level with $BER < 10^{-3}$

Frequency Offset	Blocker Level	Blocking
+0.75 MHz	-47.5 dBm	55.0 dBC/58.0 dBS
-0.75 MHz	-47.5 dBm	55.0 dBC/58.0 dBS
+1.0 MHz	-44.5 dBm	58.0 dBC/61.0 dBS
-1.0 MHz	-44.5 dBm	58.0 dBC/61.0 dBS
+1.5 MHz	-42.0 dBm	60.5 dBC/63.5 dBS
-1.5 MHz	-42.0 dBm	60.5 dBC/63.5 dBS
+10 MHz	-35.5 dBm	67.0 dBC/70.0 dBS
-10 MHz	-35.5 dBm	67.0 dBC/70.0 dBS

The ATA5823/ATA5824 can also receive FSK and ASK modulated signals if they are much higher than the I1dBCP. It can typically receive useful signals at $+10$ dBm. This is often referred to as the nonlinear dynamic range which is the maximum to minimum receiving signal which is 115.5 dB for 433.92 MHz/FSK/20 Kbit/s/ ± 19.5 kHz/ Manchester. This value is useful if two transceivers have to communicate and are very close to each other.

In a keyless entry system there is another blocking characteristic that has to be considered. A keyless entry system has a typical service range of about 30 m with a receiver sensitivity of about -106 dBm to -109 dBm. In some cases, large blockers limit this service range, and it is important to know how large this blockers can be until the system doesn't work anymore and the user has to use its key. With a recommended sensitivity of about -85 dBm, the system works just around the car. Figure 7-6 and Figure 7-7 on page 17 show the blocking performance in this important case with a useful signal of -85 dBm 433.92 MHz/FSK/20 Kbit/s/ ± 19.5 kHz/ Manchester.

As can be seen the system works even with blockers above the compression point. This is due to a wide bandwidth automatic gain control that begins to work if blockers above the compression point are at the antenna input and increasing the current in the LNA/Mixer to get a better compression point needed to handle these large blockers.

Figure 7-6. ± 2.5 MHz Blocking Characteristic for -85 dBm Useful Signal at 433.92 MHz

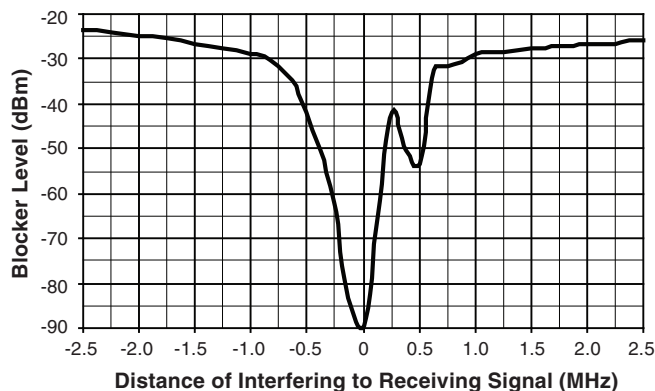
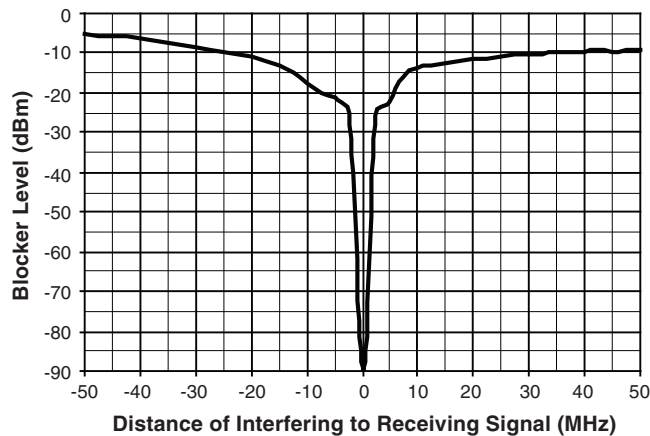

Figure 7-7. ±50 MHz Blocking Characteristic for –85 dBm Useful Signal at 433.92 MHz

This high blocking performance makes it even possible for some applications using quarter wave whip antennas to use a simple LC band-pass filter instead of a SAW filter in the receiver. When designing such a LC filter, take into account that the 3 dB blocking at $433.92 \text{ MHz}/2 = 216.96 \text{ MHz}$ is 42 dBC and at $433.92 \text{ MHz}/3 = 144.64 \text{ MHz}$ is 47 dBC and at $2 \times (433.92 \text{ MHz} + 226 \text{ kHz}) + -226 \text{ kHz} = 868.066 \text{ MHz}/868.518 \text{ MHz}$ is 50 dBC. And especially that at $3 \times (433.92 \text{ MHz} + 226 \text{ kHz}) + 226 \text{ kHz} = 1302.664 \text{ MHz}$ the receiver has a second LO harmonic receiving frequency with only 17 dBC blocking.

7.8 Inband Disturbors, Data Filter, Quasi-peak Detector, Data Slicer

If a disturbing signal falls into the received band, or a blocker is not a continuous wave, the performance of a receiver strongly depends on the circuits after the IF filter. Hence the demodulator, data filter and data slicer are important in that case.

The data filter of the ATA5823/ATA5824 implies a quasi-peak detector. This results in a good suppression of above mentioned disturbors and exhibits a good carrier to noise performance. The required ratio of useful signal to disturbing signal, at a BER of 10^{-3} is less than 12 dB in ASK mode and less than 3 dB (BR_Range_0 ... BR_Range_2) and 6 dB (BR_Range_3) in FSK mode. Due to the many different possible waveforms these numbers are measured for signal as well as for disturbors with peak amplitude values. Note that these values are worst case values and are valid for any type of modulation and modulating frequency of the disturbing signal as well as the receiving signal. For many combinations, lower carrier to disturbing signal ratios are needed.

7.9 TEST3 Output

The internal raw output signal of the demodulator Demod_Out is available at pin TEST3. TEST3 is an open drain output and must be connected to a pull-up resistor if it is used (typically 100 kΩ), otherwise no signal is present at that pin. This signal is mainly used for debugging purposes during the setup of a new application, since the received data signal can be seen there without any digital processing.

7.10 RSSI Output

The output voltage of the pin RSSI is an analog voltage, proportional to the input power level. Using the RSSI output signal, the signal strength of different transmitters can be distinguished. The usable dynamic range of the RSSI amplifier is 70 dB, the input power range P_{RFIN} is -115 dBm to -45 dBm and the gain is 8 mV/dB. [Figure 7-8 on page 18](#) shows the RSSI characteristic of a typical device at 433.92 MHz with $V_{S1} = V_{S2} = 2.15V$ to $3.6V$ and $T_{amb} = -40^{\circ}C$ to $+105^{\circ}C$ with a matched input according to [Table 7-2 on page 12](#) and [Figure 7-1 on page 11](#). At 868.3 MHz about 2.7 dB more signal level and at 315 MHz about 1 dB less signal level is needed for the same RSSI results.

Figure 7-8. Typical RSSI Characteristic at 433.92 MHz versus Temperature and Supply Voltage

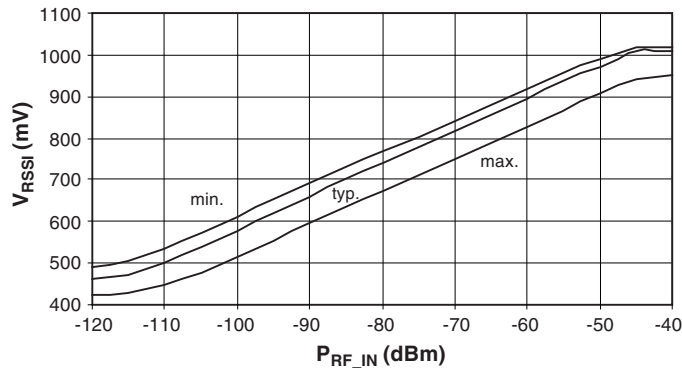

7.11 Frequency Synthesizer and Channel Selection

The synthesizer is a fully integrated fractional-N design with internal loop filters for receive and transmit mode. The XTO frequency f_{XTO} is the reference frequency FREF for the synthesizer. The bits FR0 to FR12 in control registers 2 and 3 (see [Table 12-7 on page 38](#) and [Table 12-10 on page 39](#)) are used to adjust the deviation of f_{XTO} . In half-duplex transmit mode, at 433.92 MHz, the carrier has a phase noise of -111 dBc/Hz at 1 MHz and spurious at FREF of -70 dBc with a high PLL loop bandwidth allowing the direct modulation of the carrier with 20 Kbit/s Manchester data. Due to the closed loop modulation, any spurious caused by this modulation are effectively filtered out as can be seen in [Figure 7-11 on page 20](#). In RX mode the synthesizer has a phase noise of -120 dBc/Hz at 1 MHz and spurious of -72 dBc.

The initial tolerances of the crystal oscillator due to crystal frequency tolerances, internal capacitor tolerances and the parasitics of the board have to be compensated at manufacturing setup with control registers 2 and 3 as can be seen in [Table 9-1 on page 30](#). The other control words for the synthesizer needed for ASK, FSK and receive/transmit switching are calculated internally. The RF (Radio Frequency) resolution is equal to the XTO frequency divided by 16384 which is 777.1 Hz at 315.0 MHz, 808.9 Hz at 433.92 MHz and 818.59 Hz at 868.3 MHz.

The frequency control word FREQ in control registers 2 and 3 can be programmed in the range of 1000 to 6900, hence every frequency within the 433 MHz and 868 MHz ISM bands can be programmed as receive and as transmit frequency and the position of channels within these ISM bands can be chosen arbitrarily (see [Table 9-1 on page 30](#)).

Care must be taken regarding the harmonics of the CLK output signal as well as to the harmonics produced by a microprocessor clocked with it, since these harmonics can disturb the reception of signals. In a single channel system using $FREQ = 3803$ to 4053 ensures that harmonics of this signal, do not disturb the receive mode.

7.12 FSK/ASK Transmission

Due to the fast modulation capability of the synthesizer and the high resolution, the carrier can be internally FSK modulated which simplifies the application of the transceiver. The deviation of the transmitted signal is ± 24 digital frequency steps of the synthesizer which is equal to ± 18.65 kHz for 315 MHz, ± 19.41 kHz for 433.92 MHz and ± 19.64 kHz for 868.3 MHz.

Due to closed loop modulation with PLL filtering, the modulated spectrum is very clean, meeting ETSI and CEPT regulations when using a simple LC filter for the power amplifier harmonics as it is shown in [Figure 4-1](#). In ASK mode the frequency is internally connected to the center of the FSK transmission and the power amplifier is switched on and off to perform the modulation.

[Figure 7-9](#) to [Figure 7-11](#) on [page 20](#) show the spectrum of the FSK modulation with pseudo-random data with 20 Kbit/s/ ± 19.41 kHz/Manchester and 5 dBm output power.

Figure 7-9. FSK-modulated TX Spectrum (433.92 MHz/20 Kbit/s/ ± 19.41 kHz/Manchester Code)

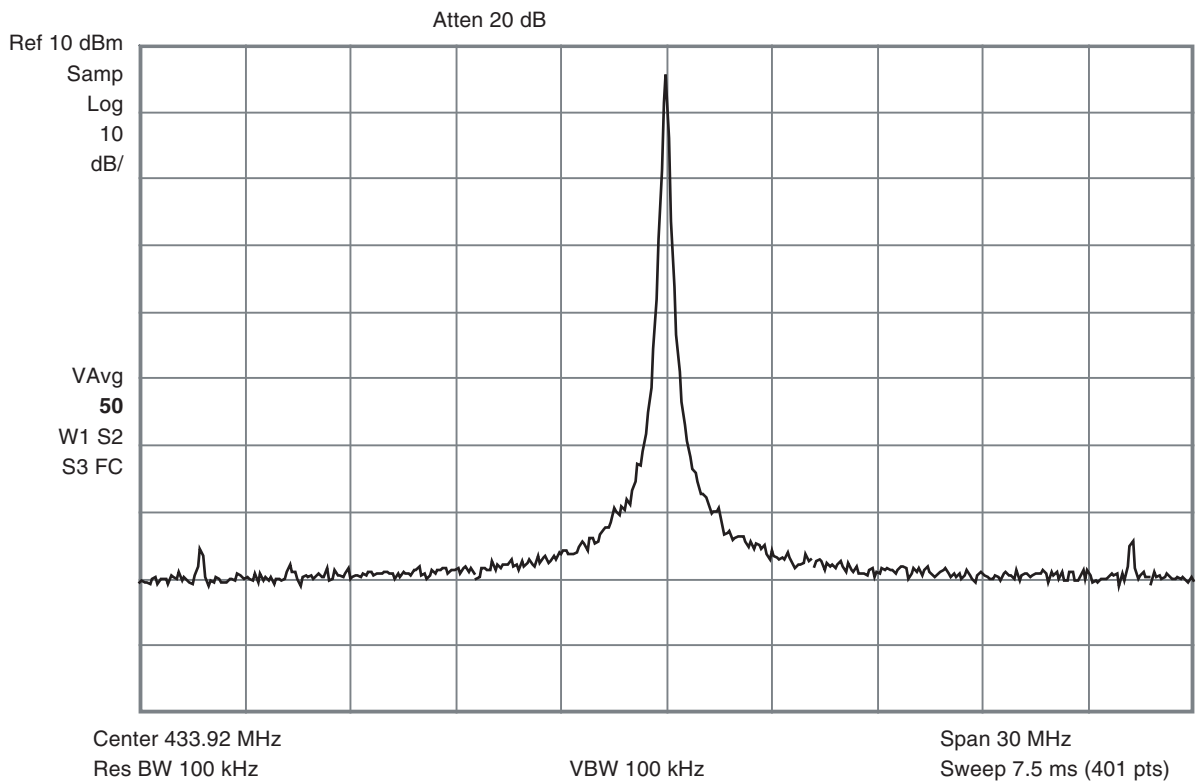

Figure 7-10. Unmodulated TX Spectrum 433.92 MHz - 19.41 kHz (f_{FSK_L})

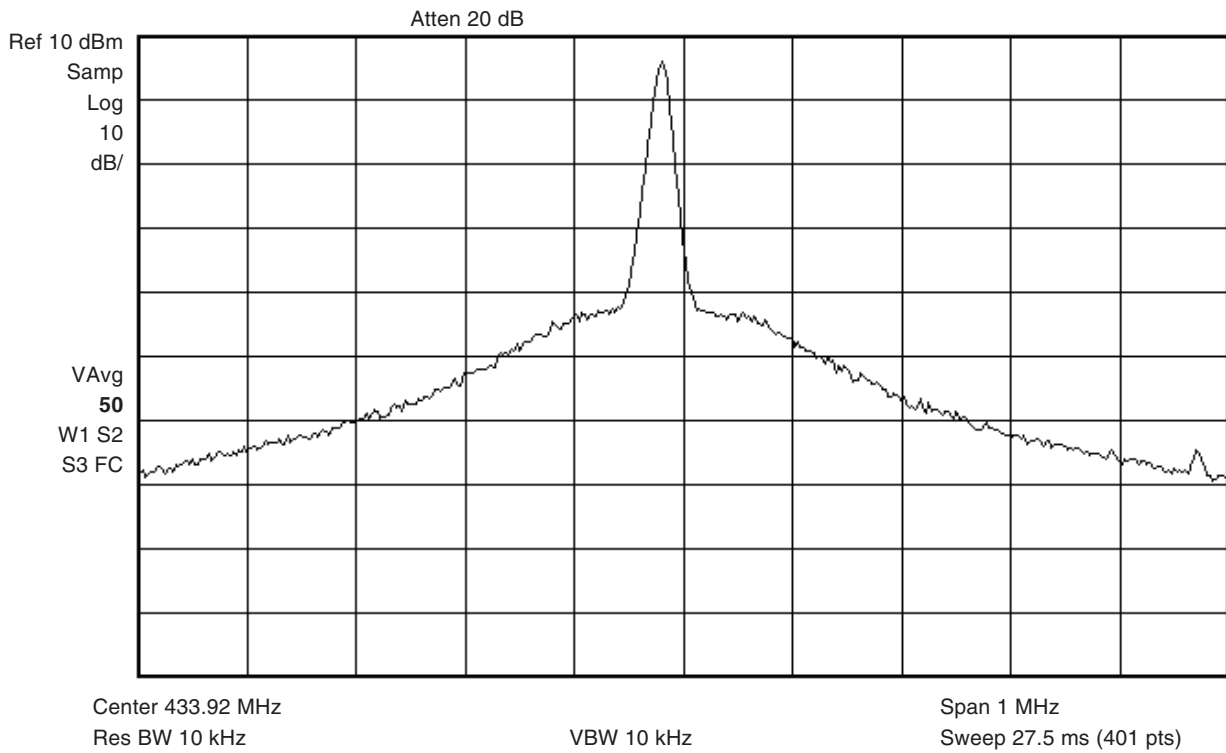
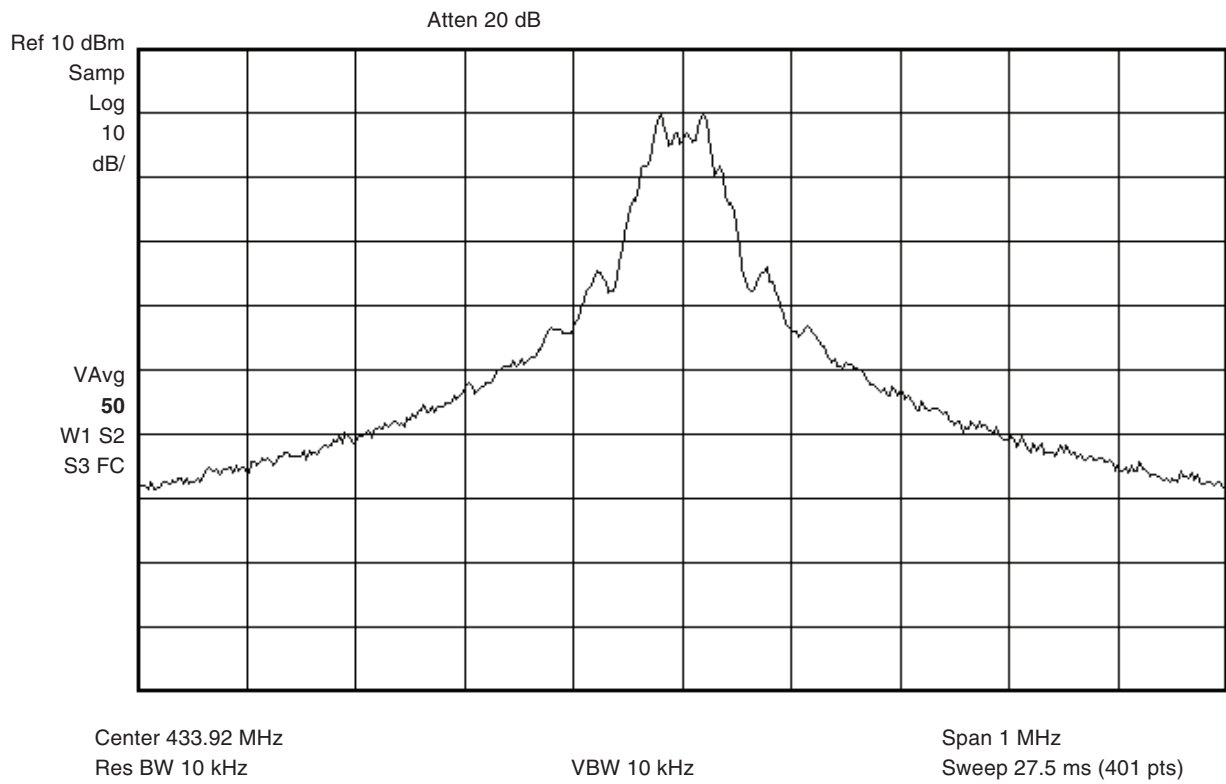

Figure 7-11. FSK-modulated TX Spectrum (433.92 MHz/20 Kbit/s/ \pm 19.41 kHz/Manchester Code)



7.13 Output Power Setting and PA Matching at RF_OUT

The Power Amplifier (PA) is a single-ended open collector stage which delivers a current pulse which is nearly independent of supply voltage, temperature and tolerances due to band-gap stabilization. Resistor R_1 (see [Figure 7-12 on page 22](#)) sets a reference current which controls the current in the PA. A higher resistor value results in a lower reference current, a lower output power and a lower current consumption of the PA. The usable range of R_1 is 15 k Ω to 56 k Ω . The PWR_H pin switches the output power range between about 0 dBm to 5 dBm (PWR_H = GND) and 5 dBm to 10 dBm (PWR_H = AVCC) by multiplying this reference current with a factor 1 (PWR_H = GND) and 2.5 (PWR_H = AVCC) which corresponds to about 5 dB more output power.

If the PA is switched off in TX mode, the current consumption without output stage and with $V_{S1} = V_{S2} = 3V$, $T_{amb} = 25^\circ C$ is typically 6.5 mA for 868.3 MHz and 6.95 mA for 315 MHz and 433.92 MHz.

The maximum output power is achieved with optimum load resistances R_{Lopt} according to [Table 7-7 on page 22](#). The compensation of the 1.0 pF output capacitance of the RF_OUT pin will be achieved by absorbing it into the matching network, consisting of L_1 , C_1 , C_3 as shown in [Figure 7-12 on page 22](#). There must be also a low resistive DC path to AVCC to deliver the DC current of the power amplifier's last stage. The matching of the PA output was done with the circuit according to [Figure 7-12 on page 22](#) with the values in [Table 7-7](#). Note that value changes of these elements may be necessary to compensate individual board layout parasitics.

Example:

According to [Table 7-7 on page 22](#), with a frequency of 433.92 MHz and output power of 11 dBm, the overall current consumption is typically 17.8 mA. Hence the PA needs 17.8 mA - 6.95 mA = 10.85 mA in this mode which corresponds to an overall power amplifier efficiency of the PA of $(10^{(11dBm/10)} \times 1 \text{ mW}) / (3V \times 10.85 \text{ mA}) \times 100\% = 38.6\%$ in this case.

Using a higher resistor in this example of $R1 = 1.091 \times 22 \text{ k}\Omega = 24 \text{ k}\Omega$ results in 9.1% less current in the PA of 10.85 mA/1.091 = 9.95 mA and $10 \times \log(1.091) = 0.38 \text{ dB}$ less output power if using a new load resistance of $300\Omega \times 1.091 = 327\Omega$. The resulting output power is then 11 dBm - 0.38 dB = 10.6 dBm and the overall current consumption is 6.95 mA + 9.95 mA = 16.9 mA.

The values of [Table 7-7 on page 22](#) were measured with standard multi-layer chip inductors with quality factors Q according to [Table 7-7 on page 22](#).

Looking to the 433.92 MHz/11 dBm case with the quality factor of $Q_{L1} = 43$ the loss in this inductor L_1 is estimated with the parallel equivalent resistance of the inductor $R_{loss} = 2 \times \pi \times f \times L1 \times Q_{L1}$ and the matching loss with $10 \log(1 + R_{Lopt}/R_{loss})$ which is equal to 0.32 dB losses in this inductor. Taking this into account the PA efficiency is then 42% instead of 38.6%.

Be aware that the high power mode (PWR_H = AVCC) can only be used with a supply voltage higher than 2.7V, whereas the low power mode (PWR_H = GND) can be used down to 2.15V as can be seen in the section [“Electrical Characteristics: General” on page 72](#).

The supply blocking capacitor C_2 (10 nF) in [Figure 7-12 on page 22](#) has to be placed close to the matching network because of the RF current flowing through it.

An internal programmable resistor SETPWR is programmable with the control register 8, described in [Table 12-25 on page 43](#). It can be used in conjunction with an external resistor to adjust the output power by connection it like in the application [Figure 5-1 on page 8](#) or [Figure 6-1 on page 9](#). To do that the output power should be adjusted with an external resistor about 50% lower than needed for the target output power and reduced with the programmable resistor during production test until the target power is as close as possible to the target. For example, if using 433.92 MHz at 5 dBm, a resistor of 12k instead of 24k is used and values of PWSET between 25 and 29 can be used to achieve an output power within 5 dBm ± 0.5 dB over production. In full-duplex mode this internal resistor is used to reduce the output power for full-duplex operation versus the power in half-duplex operation. Note that this resistor is temperature stable but has tolerances of $\pm 20\%$ and introduces, therefore, additional output power tolerances, it is recommended to adjust output power during the production test if using the SETPWR resistor.

Figure 7-12. Power Setting and Output Matching

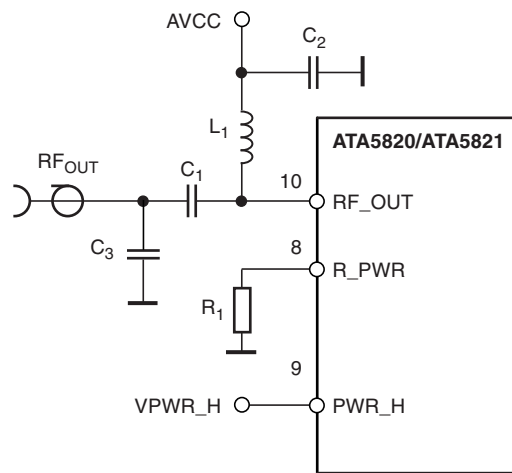

Table 7-7. Measured Output Power and Current Consumption with $V_{S1} = V_{S2} = 3V$, $T_{amb} = 25^{\circ}C$

Frequency (MHz)	TX Current (mA)	Output Power (dBm)	R1 (k Ω)	VPWR_H	R _{Lopt} (Ω)	L ₁ (nH)	Q _{L1}	C ₁ (pF)	C ₃ (pF)
315	8.5	0.4	56	0	2500	82	28	1.5	0
315	10.5	5.7	27	0	920	68	32	2.2	0
315	16.7	10.5	27	AVCC	350	56	35	3.9	0
433.92	8.6	0.1	56	0	2300	56	40	0.75	0
433.92	11.2	6.2	22	0	890	47	38	1.5	0
433.92	17.8	11	22	AVCC	300	33	43	2.7	0
868.3	9.3	-0.3	33	0	1170	12	58	1.0	3.3
868.3	11.5	5.4	15	0	471	15	54	1.0	0
868.3	16.3	9.5	22	AVCC	245	10	57	1.5	0

7.14 Output Power and TX Supply Current versus Supply Voltage and Temperature

Table 7-8 shows the measurement of the output power for a typical device with $V_{S1} = V_{S2} = V_S$ in the 433.92 MHz and 6.2 dBm case versus temperature and supply voltage measured according to Figure 7-12 on page 22 with components according to Table 7-7 on page 22. As opposed to the receiver sensitivity the supply voltage has here the major impact on output power variations because of the large signal behavior of a power amplifier. Thus a 5V system using the internal voltage regulator shows much less variation than a 2.15V to 3.6V battery system because the AVCC supply voltage is $3.25V \pm 0.25V$ for a 5V system.

The reason is that the amplitude at the output RF_OUT with optimum load resistance is $AVCC - 0.4V$ and the power is proportional to $(AVCC - 0.4V)^2$ if the load impedance is not changed. This means that the theoretical output power reduction if reducing the supply voltage from 3.0V to 2.15V is $10 \log \left(\frac{(3V - 0.4V)^2}{(2.15V - 0.4V)^2} \right) = 3.4 \text{ dB}$. Table 7-8 shows that principle behavior in the measurements. This is not the same case for higher voltages, since here, increasing the supply voltage from 3V to 3.6V should theoretical increase the power by 1.8 dB, but only 0.9 dB in the measurements shows that the amplitude does not increase with the supply voltage because the load impedance is optimized for 3V and the output amplitude stays more constant because of the current source nature of the output.

Table 7-8. Measured Output Power and Supply Current at 433.92 MHz, PWR_H = GND

$V_S = V_{S1} = V_{S2}$	2.15V	3.0V	3.6V
$T_{amb} = -40^\circ\text{C}$	9.25 mA 3.2 dBm	10.19 mA 5.5 dBm	10.78 mA 6.2 dBm
$T_{amb} = +25^\circ\text{C}$	10.2 mA 3.4 dBm	11.19 mA 6.2 dBm	11.79 mA 7.1 dBm
$T_{amb} = +105^\circ\text{C}$	10.9 mA 3.0 dBm	12.02 mA 5.4 dBm	12.73 mA 6.3 dBm

Table 7-9 shows the relative changes of the output power of a typical device compared to 3.0V/25°C. As can be seen, a temperature change to -40°C as well as to $+105^\circ\text{C}$ reduces the power by less than 1 dB due to the band-gap regulated output current. Measurements of all the cases in Table 7-7 on page 22 overtemperature and supply voltage have shown about the same relative behavior as shown in Table 7-9.

Table 7-9. Measurements of Typical Output Power Relative to 3 V/25°C

$V_S = V_{S1} = V_{S2}$	2.15V	3.0V	3.6V
$T_{amb} = -40^\circ\text{C}$	-3.0 dB	-0.7 dB	0 dB
$T_{amb} = +25^\circ\text{C}$	-2.8 dB	0 dB	+0.9 dB
$T_{amb} = +105^\circ\text{C}$	-3.2 dB	-0.8 dB	+0.1 dB

7.15 RX/TX Switch

The RX/TX switch decouples the LNA from the PA in TX mode, and directs the received power to the LNA in RX mode. To do this, it has a low impedance to GND in TX mode and a high impedance to GND in RX mode. The pin 38 (RX_TX2) must always be connected to GND in the application. To design a proper RX/TX decoupling a linear simulation tool for radio frequency design together with the measured device impedances of [Table 7-1 on page 11](#), [Table 7-7 on page 22](#), [Table 7-10 on page 24](#) and [Table 7-11 on page 25](#) should be used. The exact element values have to be found on board. [Figure 7-13 on page 24](#) shows an approximate equivalent circuit of the switch. The principal switching operation is described here according to the application of [Figure 3-1 on page 6](#). The application of [Figure 4-1 on page 7](#) works similarly.

Table 7-10. Impedance of the RX/TX Switch RX_TX2 Shorted to GND

Frequency	Z(RX_TX1) TX mode	Z(RX_TX1) RX mode
315 MHz	$(4.8 + j3.2)\Omega$	$(11.3 - j214)\Omega$
433.92 MHz	$(4.5 + j4.3)\Omega$	$(10.3 - j153)\Omega$
868.3 MHz	$(5 + j9)\Omega$	$(8.9 - j73)\Omega$

Figure 7-13. Equivalent Circuit of the Switch

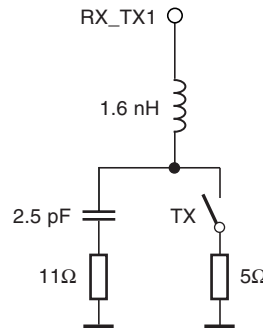

7.16 Matching Network in TX Mode

In TX mode the 20 mm long and 0.4 mm wide transmission line which is much shorter than $\lambda/4$ is approximately switched in parallel to the capacitor C_9 to GND. The antenna connection between C_8 and C_9 has an impedance of about 50Ω looking from the transmission line into the loop antenna with pin RF_OUT, L_2 , C_{10} , C_8 and C_9 connected (using a C_9 without the added 7.6 pF capacitor as discussed later). The transmission line can be approximated with a 16 nH inductor in series with a 1.5Ω resistor, the closed switch can be approximated according to [Table 7-10](#) with the series connection of 1.6 nH and 5Ω in this mode. To have a parallel resonant high impedance circuit with little RF power going into it looking, from the loop antenna into the transmission line a capacitor of about 7.6 pF to GND is needed at the beginning of the transmission line (this capacitor is later absorbed into C_9 , which is then higher as needed for 50Ω transformation). To keep the 50Ω impedance in RX mode at the end of this transmission line C_7 has to be also about 7.6 pF. This reduces the TX power by about 0.5 dB at 433.92 MHz compared to the case where the LNA path is completely disconnected.

7.17 Matching Network in RX Mode

In RX mode the RF_OUT pin has a high impedance of about 7 k Ω in parallel with 1.0 pF at 433.92 MHz as can be seen in [Table 7-11 on page 25](#). This together with the losses of the inductor L_2 with 120 nH and $Q_{L_2} = 25$ gives about 3.7 k Ω loss impedance at RF_OUT. Since the optimum load impedance in TX mode for the power amplifier at RF_OUT is 890 Ω the loss associated with the inductor L_2 and the RF_OUT pin can be estimated to be $10 \times \log(1 + 890/3700) = 0.95$ dB compared to the optimum matched loop antenna without L_2 and RF_OUT. The switch represents, in this mode at 433.92 MHz, about an inductor of 1.6 nH in series with the parallel connection of 2.5 pF and 2.0 k Ω . Since the impedance level at pin RX_TX1 in RX mode is about 50 Ω there is only a negligible damping of the received signal by about 0.1 dB. When matching the LNA to the loop antenna the transmission line and the 7.6 pF part of C_9 has to be taken into account when choosing the values of C_{11} and L_1 so that the impedance seen from the loop antenna into the transmission line with the 7.6 pF capacitor connected is 50 Ω .

Since the loop antenna in RX mode is loaded by the LNA input impedance the loaded Q of the loop antenna is lowered by about a factor of 2 in RX mode hence the antenna bandwidth is higher than in TX mode.

Table 7-11. Impedance RF_OUT Pin in RX mode

Frequency	Z(RF_OUT)RX	R _p /C _p
315 MHz	36 Ω -j 502 Ω	7 k Ω / 1.0 pF
433.92 MHz	19 Ω -j 366 Ω	7 k Ω / 1.0 pF
868.3 MHz	2.8 Ω -j 141 Ω	7 k Ω / 1.3 pF

Note that if matching to 50 Ω , like in [Figure 4-1 on page 7](#), a high Q wire wound inductor with a $Q > 70$ should be used for L_2 to minimize its contribution to RX losses which will otherwise be dominant. The RX and TX losses will be in the range of 1.0 dB there.

8. RF Transceiver in Full-duplex Mode

The full-duplex mode of the ATA5823/ATA5824 is intended to be used for the purpose of security against a so called relay attack in passive entry systems. A property of such a passive entry system is that the user has not to push a key fob button like in a keyless entry system. If the user approaches to the door of the car it will wake up the key (in most cases with a low frequency 125 kHz signal) and the communication between the key and the car starts without interaction of the user and afterwards the door opens.

Due to this new feature of the system there is a new possibility of entering a car without permission. One can trigger this communication, take the 125 kHz signal from the car, remodulate it on another carrier and transmit it over a much longer distance than intended by the system. Then receive this signal and remodulate it onto the 125 kHz carrier and retransmit this signal close to the user having the key fob with permission for the car. Such a system is called an RF-Relay and therefore this kind of attack is called relay attack. The high frequency signals of the ATA5823/ATA5824 could be treated the same way if only a half-duplex mode is used within a passive entry system. If using half-duplex RF transceivers, the attacker can switch the direction of the relay with a transmit power detector.