



Chipsmall Limited consists of a professional team with an average of over 10 year of expertise in the distribution of electronic components. Based in Hongkong, we have already established firm and mutual-benefit business relationships with customers from,Europe,America and south Asia,supplying obsolete and hard-to-find components to meet their specific needs.

With the principle of “Quality Parts,Customers Priority,Honest Operation,and Considerate Service”,our business mainly focus on the distribution of electronic components. Line cards we deal with include Microchip,ALPS,ROHM,Xilinx,Pulse,ON,Everlight and Freescale. Main products comprise IC,Modules,Potentiometer,IC Socket,Relay,Connector.Our parts cover such applications as commercial,industrial, and automotives areas.

We are looking forward to setting up business relationship with you and hope to provide you with the best service and solution. Let us make a better world for our industry!



Contact us

Tel: +86-755-8981 8866 Fax: +86-755-8427 6832

Email & Skype: info@chipsmall.com Web: www.chipsmall.com

Address: A1208, Overseas Decoration Building, #122 Zhenhua RD., Futian, Shenzhen, China



Features

- Temperature and Voltage Compensated Frequency (Fully Integrated Oscillator)
- Warning Indication of Lamp Failure by Means of Frequency Doubling
- Voltage Dependence of the Indicator Lamps also Compensated for Lamp Failure
- Relay Output with High Current Capability and Low Saturation Voltage
- Frequency Doubling only During Direction Mode
- Temperature Compensated Threshold for Lamp Failure Detection
- Overvoltage and Undervoltage Shut Down of the Relay Outputs
- Quiescent Current $I \leq 10 \mu\text{A}$ (Switches Open)
- EMI Protection According to ISO TR 7637/1, Test Level 4 (Exclusive Load Dump)
- Reversed Battery Protection by Means of a Serial Resistor and Relay Coil Connected
- Load Dump Protection 80 V with External Protection Components
- 12 V/24 V Application
- Package: SO16

Electrostatic sensitive device.

Observe precautions for handling.



Description

The integrated circuit ATA6140 is used in relay-controlled automotive flashers. With two output stages, each side of the vehicle is controlled separately. A left and a right direction indicator input with only a small control current makes switch contacts for small loads possible. The separate hazard warning input simplifies the construction of the hazard switch. Lamp outage is indicated by frequency doubling during direction mode. Thanks to the extreme low current consumption the ATA6140 can be connected to the battery directly.

Figure 1. Block Diagram

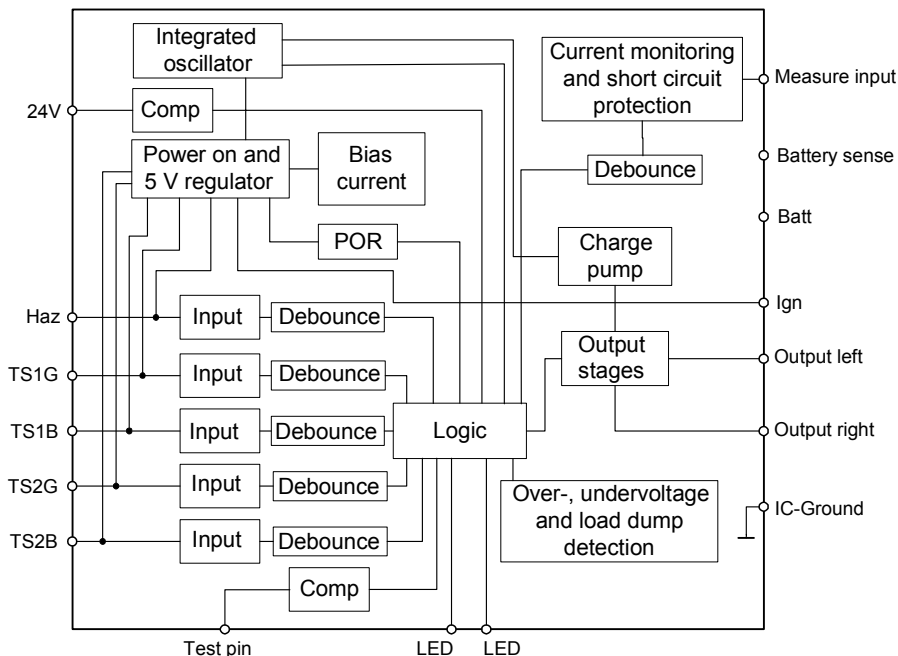

Two-relay Flasher

ATA6140

Pin Configuration

Figure 2. Pinning SO16

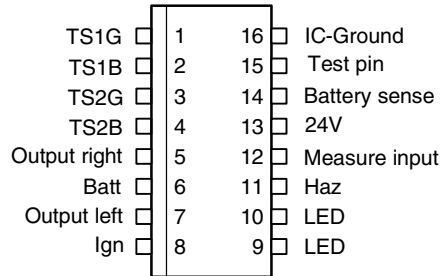

Pin Description

Pin	Symbol	Function
1	TS1G	Input left ground
2	TS1B	Input left battery
3	TS2G	Input right ground
4	TS2B	Input right battery
5	Output right	Output right
6	Batt	Battery force
7	Output left	Output left
8	Ign	Ignition
9	LED	LED outage left
10	LED	LED outage right
11	Haz	Input hazard
12	Measure input	Measure input
13	24V	24 V version
14	Battery sense	Battery sense
15	Test pin	Test pin
16	IC-Ground	IC ground

Absolute Maximum Ratings

Stresses beyond those listed under “Absolute Maximum Ratings” may cause permanent damage to the device. This is a stress rating only and functional operation of the device at these or any other conditions beyond those indicated in the operational sections of this specification is not implied. Exposure to absolute maximum rating conditions for extended periods may affect device reliability.

Parameters	Symbol	Value	Unit
Supply voltage, pin 6	V_{VS}	6 to 40	V
Ambient temperature range	T_{amb}	-40 to +105	°C
Junction temperature range	T_j	-40 to +150	°C
Storage temperature range	T_{stg}	-55 to +150	°C

Thermal Resistance

Parameters	Symbol	Value	Unit
Maximum thermal resistance SO16	R_{thJA}	110	K/W

Operating Range

Parameters	Symbol	Value	Unit
Supply voltage, pin 6	V_{VS}	6 to 24	V
Supply voltage, pin 6 (24 V version, pin 13 to GND)	V_{VS}	18 to 33	V

Noise and Surge Immunity

Parameters	Test Conditions	Value
Conducted interferences ⁽¹⁾	ISO 7637-1	Level 4
ESD (Human Body Model)	MIL-STD-883D Method 3015.7 ⁽²⁾	2 kV
	MIL-STD-883D Method 3015.7 (pin 12 and pin 14)	1 kV
ESD FCDM (Field induced Charge Device Model)	ESD - S. 5.3	500 V

- Note:
- At both outputs a relay of minimum 130 Ω should be added (for details see application circuits Figure 4 on page 7 to Figure 11 on page 11).
 - Exclusive pin 12 and pin 14.

Electrical Characteristics

No.	Parameters	Test Conditions	Pin	Symbol	Min.	Typ.	Max.	Unit	Type*
1	Supply Voltage Range								
1.1	Supply voltage		6	V_{VS}	8		16	V	C
1.1	Supply voltage (24 V version)		6	V_{VS}	18		33	V	C
2	Current Consumption								
2.1	Quiescent current (V_S)	$V_{VS} < 16$ V switches open	6	I_{VS}			10	μ A	A
2.1	Quiescent current (V_S , 24 V version)	$V_{VS} < 33$ V switches open	6	I_{VS}			20	μ A	A
2.2	Supply current (V_S)	$V_{VS} < 16$ V	6	I_{VS}			6	mA	A
2.2	Supply current (V_S , 24 V version)	$V_{VS} < 33$ V	6	I_{VS}			8	mA	A
3	Under and Overvoltage Detection								
3.1	Undervoltage detection threshold		6	V_{VU}	6		8	V	A
3.2	Undervoltage detection delay time			t_{dUV}	2.5		10	ms	A
3.3	Overvoltage detection threshold		6	V_{VO}	18		22	V	A
3.3	Overvoltage detection threshold (24 V version)	Disabled in 24 V version (pin 13 to GND)	6	V_{VO}				V	A
4	Relay Outputs								
4.1	Current output right		5	I_{I5}			170	mA	A
4.2	Current output left		7	I_{I7}			170	mA	A
4.3	Saturation voltage right	170 mA at 23°C	5	V_{SATR}			1	V	A
4.4	Saturation voltage left	170 mA at 23°C	7	V_{SATL}			1	V	A
4.5	Leakage current right		5	I_{LEAKR}			3	μ A	A
4.5	Leakage current right (24 V version)		5	I_{LEAKR}			6	μ A	A
4.6	Leakage current left		7	I_{LEAKL}			3	μ A	A
4.6	Leakage current left (24 V version)		7	I_{LEAKL}			6	μ A	A
4.7	Start delay time right		5	T_{DR}	10		40	ms	A
4.8	Start delay time left		7	T_{DL}	10		40	ms	A
5	Control Signal Thresholds								
5.1	Frequency doubling	$V_S = 9$ V	12	V_{THFD9}	42	45	48	mV	A
5.2	Frequency doubling	$V_S = 15$ V	12	V_{THFD15}	50	53	57	mV	A
5.2	Frequency doubling (24 V version)	$V_S = 24$ V	12	V_{THFD24}		65		mV	A
5.3	Short circuit detection	$V_S = 13.5$ V	12	V_{THSC}	425	475	525	mV	B

*) Type means: A = 100% tested, B = 100% correlation tested, C = Characterized on samples, D = Design parameter

Electrical Characteristics (Continued)

No.	Parameters	Test Conditions	Pin	Symbol	Min.	Typ.	Max.	Unit	Type*
5.3	Short circuit detection (24 V version)	$V_S = 24\text{ V}$	12	V_{THSC}		650		mV	B
5.4	Temperature coefficient	-40°C to +105°C	12	C_{TH}		30		μV/K	C
5.5	Input current	$V_S = 13.5\text{ V}$	12	I_{TH}			2	μA	A
5.5	Input current (24 V version)	$V_S = 24\text{ V}$	12	I_{TH}			4	μA	A
6	LED Inputs								
6.1	Threshold left	$V_S = 13.5\text{ V}$	9	V_{LEDL}	1		4.5	V	A
6.2	Threshold right	$V_S = 13.5\text{ V}$	10	V_{LEDR}	1		4.5	V	A
6.3	Pull-up resistor left		9	R_{LEDL}	10		75	kΩ	A
6.4	Pull-up resistor right		10	R_{LEDR}	10		75	kΩ	A
7	Timing								
7.1	Basic frequency	$1/f = 706\text{ ms}$		F_B	-10.5		+12	%	A
7.2	Bright period					50		%	A
7.3	Bright period in failure mode					40		%	A
7.4	Failure frequency			F_F			$2.2 \times F_B$		A

*) Type means: A = 100% tested, B = 100% correlation tested, C = Characterized on samples, D = Design parameter

Short Circuit or Overload Detection Delay

Direction mode:
100 ms during the first bright phase, 50 ms during all following bright phases

Hazard mode: 100 ms during all bright phases

In case of overload the relay output switches off (not stored)

Bulb Outage Detection

The detection of bulb outage takes place during the bright phase. There is a delay time of typically 128 ms before ATA6140 measures the bulb current with a debounce period of 5 ms. After this time the inrush current dropped significantly.

Application hint:

It has to be considered that a slow relay contact may shorten the inrush current decay time and too high current would be measured and falsely an outage may not be detected. If operated with low supply voltage (e.g., 8 V) the relay speed could be even slower.

Flasher Operating Mode

Ignition	Input Left Ground	Input Right Ground	Input Left Ignition	Input Right Ignition	Input Hazard	Left Lamps ⁽¹⁾	Right Lamps ⁽¹⁾	Frequency in Case of Lamp Failure ⁽¹⁾
Off	Open	Open	IC-Ground	IC-Ground	Open	x	x	x
Off	Ground	Open	IC-Ground	IC-Ground	Open	x	x	x
Off	Open	Ground	IC-Ground	IC-Ground	Open	x	x	x
Off	Open	Open	IC-Ground	IC-Ground	Ground	Flash	Flash	Normal
Off	Ground	Open	IC-Ground	IC-Ground	Ground	Flash	Flash	Normal
Off	Open	Ground	IC-Ground	IC-Ground	Ground	Flash	Flash	Normal
Off	Ground	Ground	IC-Ground	IC-Ground	Ground	Flash	Flash	Normal
Off	Ground	Ground	IC-Ground	IC-Ground	Open	x	x	x ⁽²⁾
On	Open	Open	IC-Ground	IC-Ground	Open	x	x	x
On	Ground	Open	IC-Ground	IC-Ground	Open	Flash	x	Double
On	Open	Ground	IC-Ground	IC-Ground	Open	x	Flash	Double
On	Open	Open	IC-Ground	IC-Ground	Ground	Flash	Flash	Normal
On	Ground	Open	IC-Ground	IC-Ground	Ground	Flash	Flash	Normal
On	Open	Ground	IC-Ground	IC-Ground	Ground	Flash	Flash	Normal
On	Ground	Ground	IC-Ground	IC-Ground	Ground	Flash	Flash	Normal
On	Ground	Ground	IC-Ground	IC-Ground	Open	Flash	Flash	Normal
Off	V _{BATT}	V _{BATT}	Open	Open	Open	x	x	x
Off	V _{BATT}	V _{BATT}	Ignition	Open	Open	x	x	x
Off	V _{BATT}	V _{BATT}	Open	Ignition	Open	x	x	x
Off	V _{BATT}	V _{BATT}	Open	Open	Ground	Flash	Flash	Normal
Off	V _{BATT}	V _{BATT}	Ignition	Open	Ground	Flash	Flash	Normal
Off	V _{BATT}	V _{BATT}	Open	Ignition	Ground	Flash	Flash	Normal
Off	V _{BATT}	V _{BATT}	Ignition	Ignition	Ground	Flash	Flash	Normal
Off	V _{BATT}	V _{BATT}	Ignition	Ignition	Open	x	x	x ⁽³⁾
On	V _{BATT}	V _{BATT}	Open	Open	Open	x	x	x
On	V _{BATT}	V _{BATT}	Ignition	Open	Open	Flash	x	Double
On	V _{BATT}	V _{BATT}	Open	Ignition	Open	x	Flash	Double
On	V _{BATT}	V _{BATT}	Open	Open	Ground	Flash	Flash	Normal
On	V _{BATT}	V _{BATT}	Ignition	Open	Ground	Flash	Flash	Normal
On	V _{BATT}	V _{BATT}	Open	Ignition	Ground	Flash	Flash	Normal
On	V _{BATT}	V _{BATT}	Ignition	Ignition	Ground	Flash	Flash	Normal
On	V _{BATT}	V _{BATT}	Ignition	Ignition	Open	Flash	Flash	Normal

Notes: 1. x = no flashing

2. If ignition is OFF, the input level cannot be sensed (the IC is in the sleep mode). For hazard mode use the input hazard.

3. For hazard mode use input hazard or switch to battery as shown in Figure 6 on page 8 and Figure 10 on page 10.

Diagrams

Figure 3. Timing Diagram

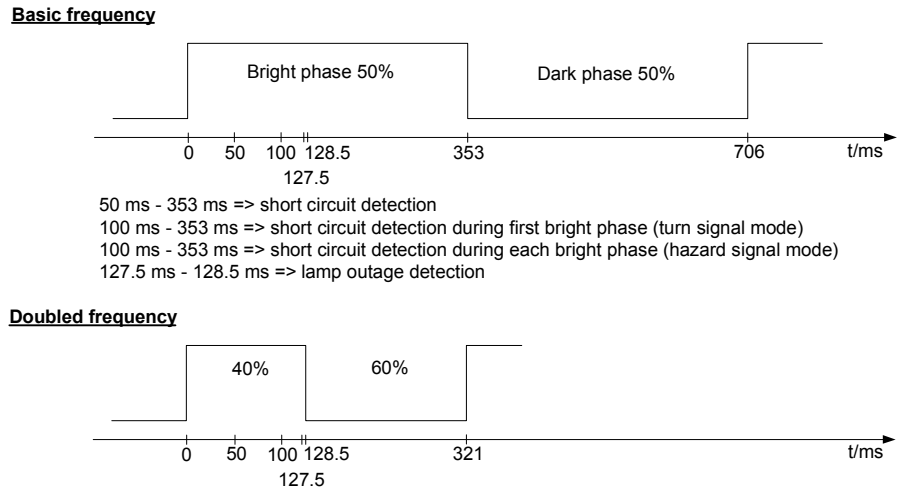

Figure 4. Application 1: 12 V Version, Turn Signal Switches to GND, Hazard Switch to GND

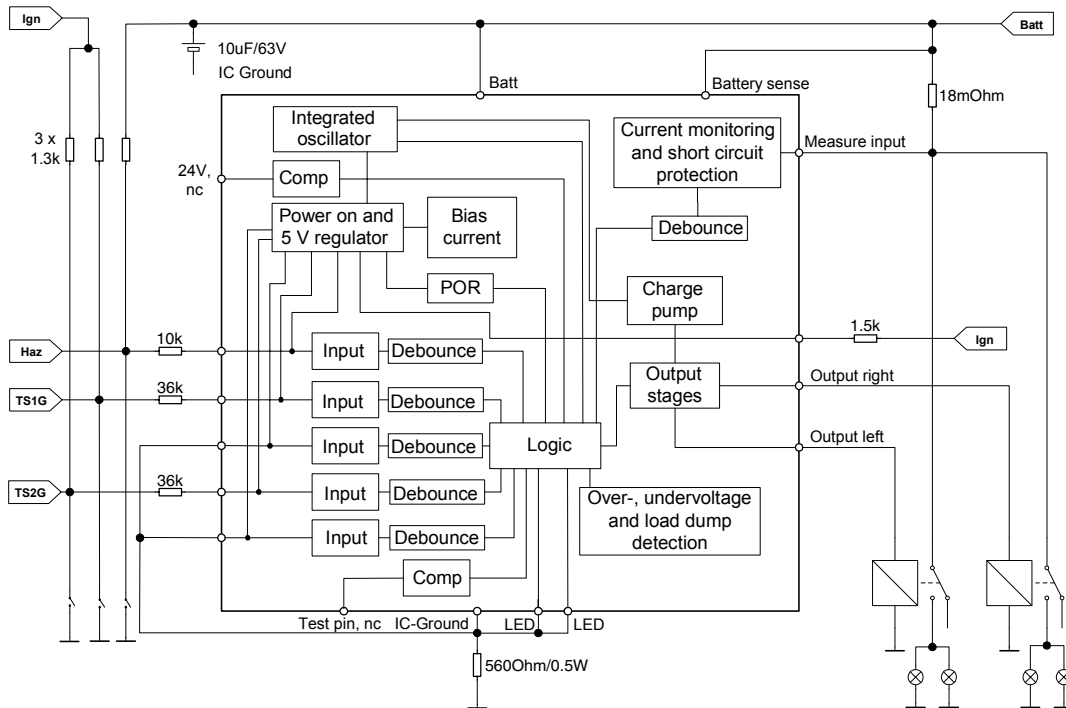

Figure 5. Application 2: 12 V Version, Turn Signal Switches to Ignition, Hazard Switch to GND

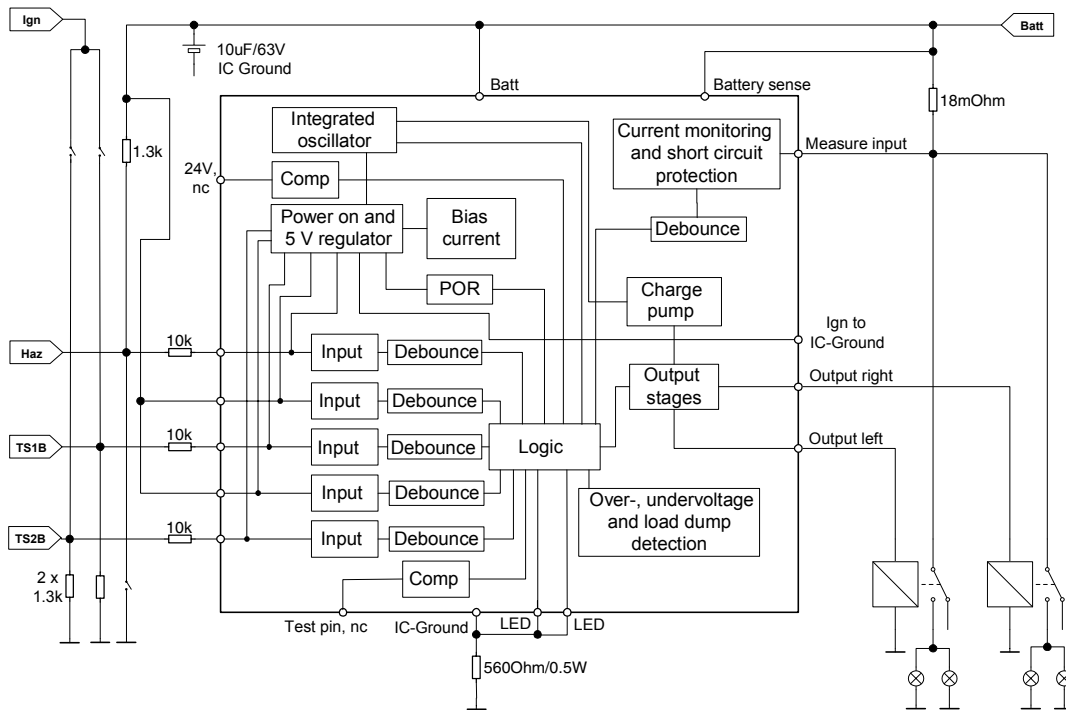

Figure 6. Application 3: 12 V Version, Turn Signal Switches to Ignition, Hazard Switch to Battery

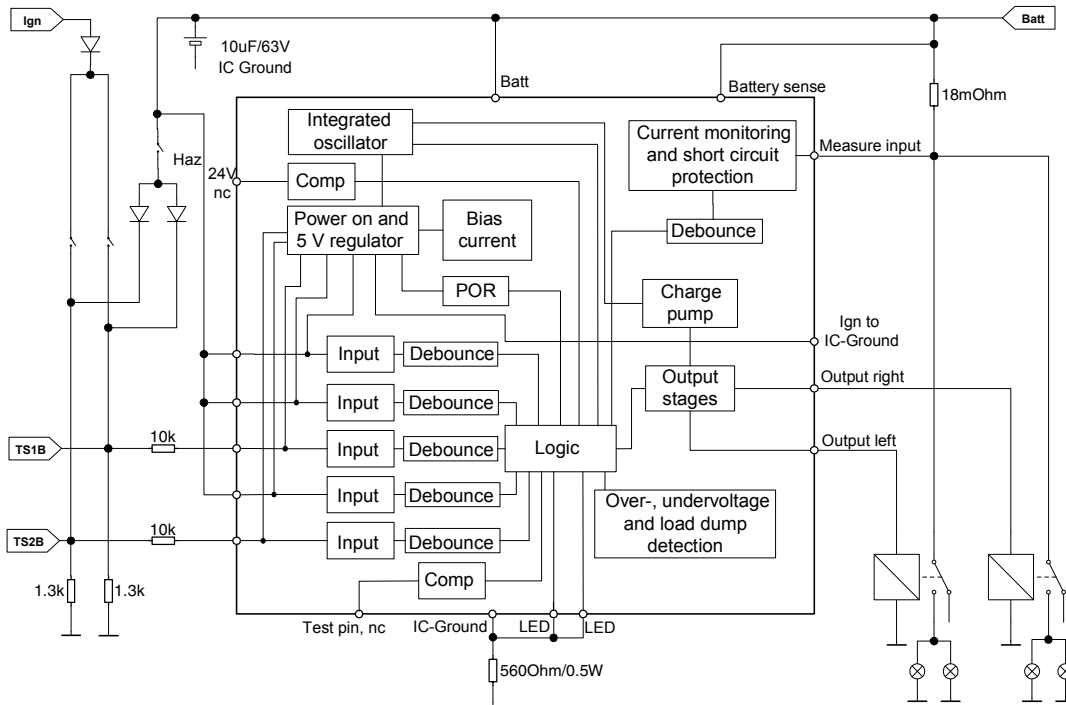

Figure 7. Application 4: 12 V Version, Turn Signal Switches to Ignition, Hazard Switch to GND, additional LED Outage

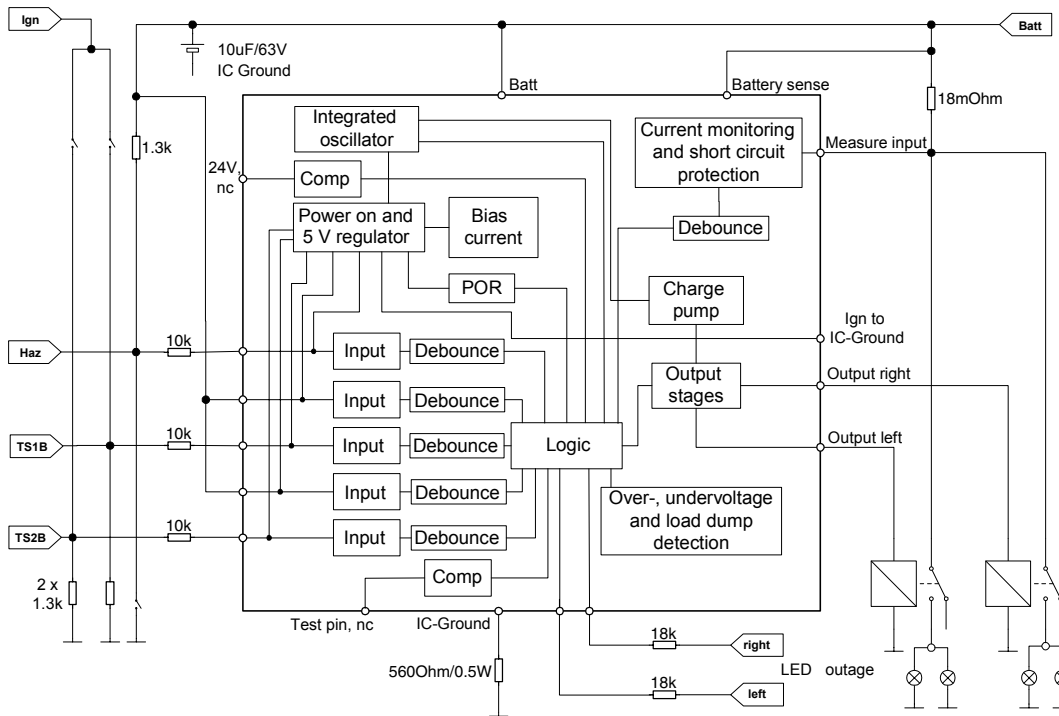

Figure 8. Application 1: 24 V Version, Turn Signal Switches to GND, Hazard Switch to GND

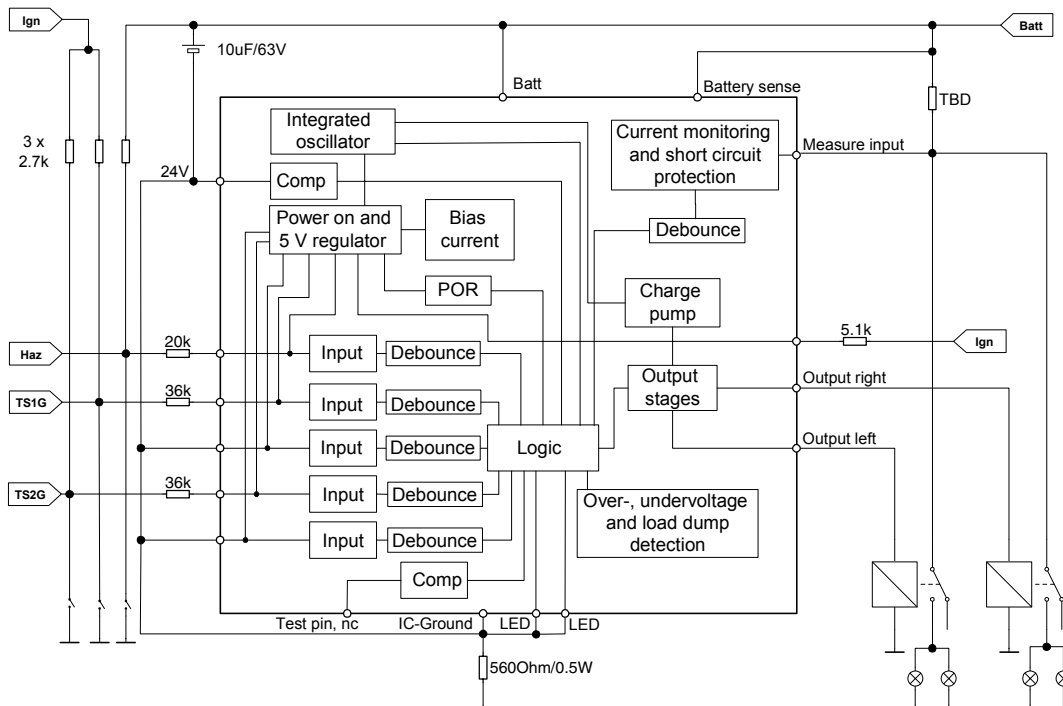

Figure 9. Application 2: 24 V Version, Turn Signal Switches to Ignition, Hazard Switch to GND

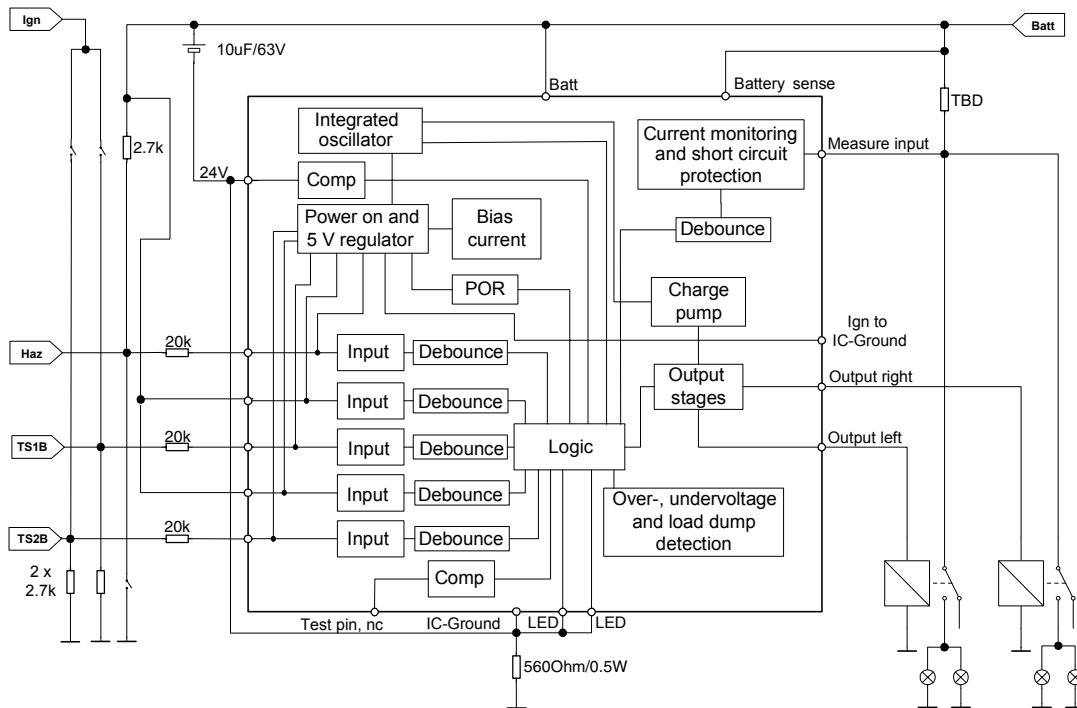

Figure 10. Application 3: 24 V Version, Turn Signal Switches to Ignition, Hazard Switch to Battery

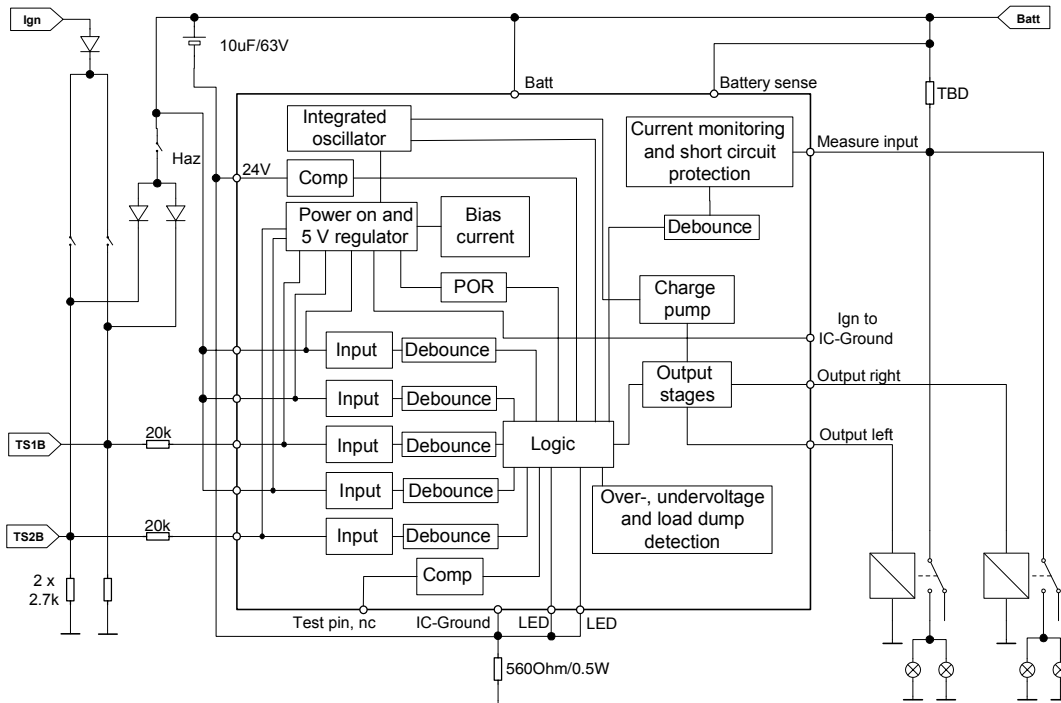
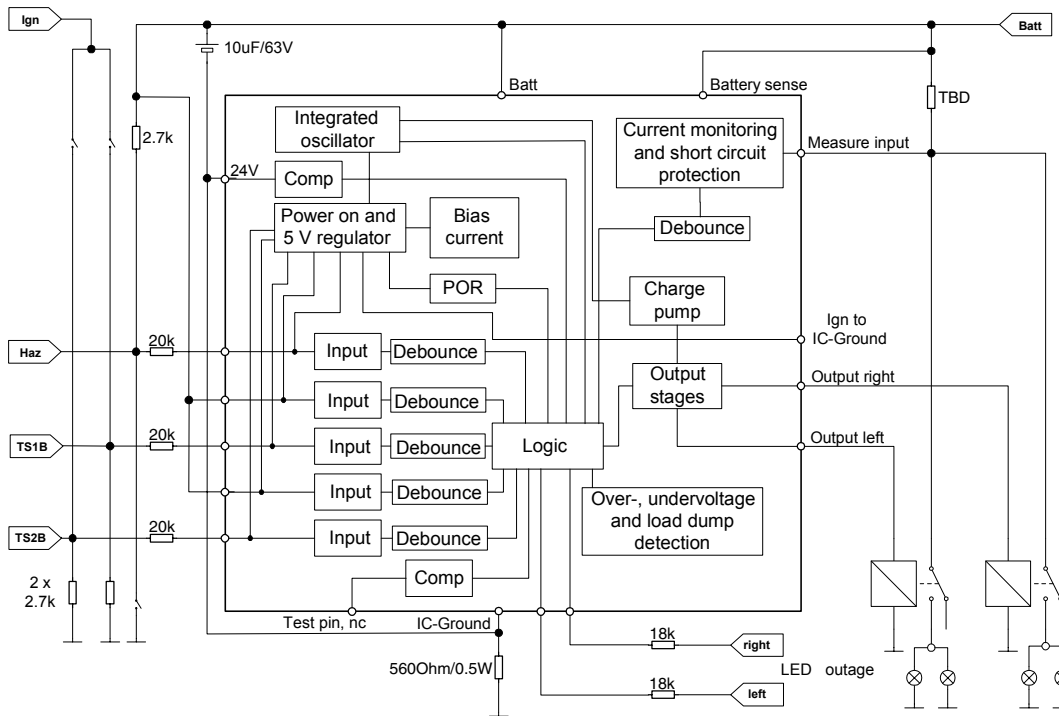

Figure 11. Application 4: 24 V Version, Turn Signal Switches to Ignition, Hazard Switch to GND, additional LED Outage



Ordering Information

Extended Type Number	Package	Remarks
ATA6140-TBQ	SO16	Taped and reeled

Package Information

Package SO16
Dimensions in mm

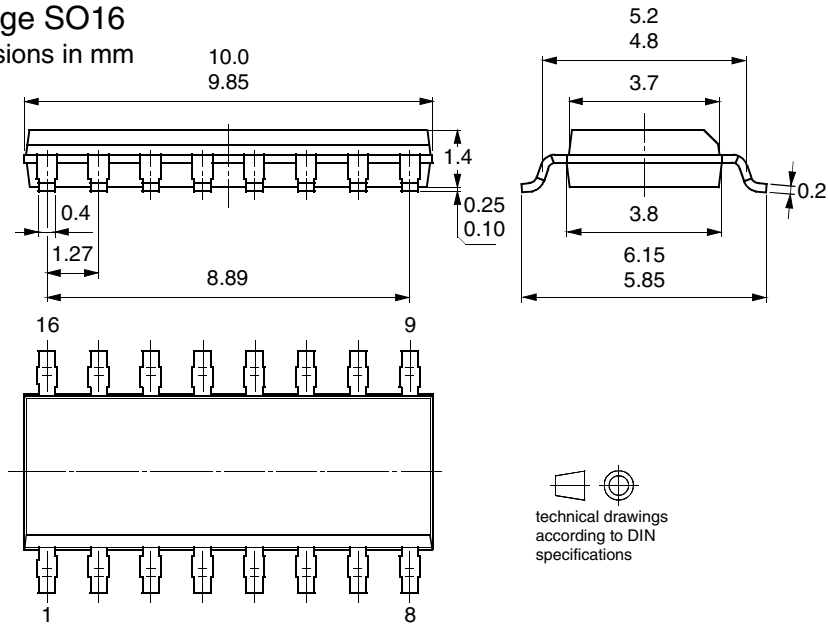



Atmel Corporation

2325 Orchard Parkway
San Jose, CA 95131, USA
Tel: 1(408) 441-0311
Fax: 1(408) 487-2600

Regional Headquarters

Europe

Atmel Sarl
Route des Arsenalux 41
Case Postale 80
CH-1705 Fribourg
Switzerland
Tel: (41) 26-426-5555
Fax: (41) 26-426-5500

Asia

Room 1219
Chinachem Golden Plaza
77 Mody Road Tsimshatsui
East Kowloon
Hong Kong
Tel: (852) 2721-9778
Fax: (852) 2722-1369

Japan

9F, Tonetsu Shinkawa Bldg.
1-24-8 Shinkawa
Chuo-ku, Tokyo 104-0033
Japan
Tel: (81) 3-3523-3551
Fax: (81) 3-3523-7581

Atmel Operations

Memory

2325 Orchard Parkway
San Jose, CA 95131, USA
Tel: 1(408) 441-0311
Fax: 1(408) 436-4314

Microcontrollers

2325 Orchard Parkway
San Jose, CA 95131, USA
Tel: 1(408) 441-0311
Fax: 1(408) 436-4314

La Chantrerie
BP 70602
44306 Nantes Cedex 3, France
Tel: (33) 2-40-18-18-18
Fax: (33) 2-40-18-19-60

ASIC/ASSP/Smart Cards

Zone Industrielle
13106 Rousset Cedex, France
Tel: (33) 4-42-53-60-00
Fax: (33) 4-42-53-60-01

1150 East Cheyenne Mtn. Blvd.
Colorado Springs, CO 80906, USA
Tel: 1(719) 576-3300
Fax: 1(719) 540-1759

Scottish Enterprise Technology Park
Maxwell Building
East Kilbride G75 0QR, Scotland
Tel: (44) 1355-803-000
Fax: (44) 1355-242-743

RF/Automotive

Theresienstrasse 2
Postfach 3535
74025 Heilbronn, Germany
Tel: (49) 71-31-67-0
Fax: (49) 71-31-67-2340

1150 East Cheyenne Mtn. Blvd.
Colorado Springs, CO 80906, USA
Tel: 1(719) 576-3300
Fax: 1(719) 540-1759

Biometrics/Imaging/Hi-Rel MPU/ High Speed Converters/RF Datacom

Avenue de Rochepleine
BP 123
38521 Saint-Egreve Cedex, France
Tel: (33) 4-76-58-30-00
Fax: (33) 4-76-58-34-80

Literature Requests

www.atmel.com/literature

Disclaimer: Atmel Corporation makes no warranty for the use of its products, other than those expressly contained in the Company's standard warranty which is detailed in Atmel's Terms and Conditions located on the Company's web site. The Company assumes no responsibility for any errors which may appear in this document, reserves the right to change devices or specifications detailed herein at any time without notice, and does not make any commitment to update the information contained herein. No licenses to patents or other intellectual property of Atmel are granted by the Company in connection with the sale of Atmel products, expressly or by implication. Atmel's products are not authorized for use as critical components in life support devices or systems.

© Atmel Corporation 2003. All rights reserved.

Atmel® and combinations thereof are the registered trademarks of Atmel Corporation or its subsidiaries.

Other terms and product names may be the trademarks of others.



Printed on recycled paper.

4560C-AUTO-10/03