



Chipsmall Limited consists of a professional team with an average of over 10 year of expertise in the distribution of electronic components. Based in Hongkong, we have already established firm and mutual-benefit business relationships with customers from,Europe,America and south Asia,supplying obsolete and hard-to-find components to meet their specific needs.

With the principle of “Quality Parts,Customers Priority,Honest Operation,and Considerate Service”,our business mainly focus on the distribution of electronic components. Line cards we deal with include Microchip,ALPS,ROHM,Xilinx,Pulse,ON,Everlight and Freescale. Main products comprise IC,Modules,Potentiometer,IC Socket,Relay,Connector.Our parts cover such applications as commercial,industrial, and automotives areas.

We are looking forward to setting up business relationship with you and hope to provide you with the best service and solution. Let us make a better world for our industry!



Contact us

Tel: +86-755-8981 8866 Fax: +86-755-8427 6832

Email & Skype: info@chipsmall.com Web: www.chipsmall.com

Address: A1208, Overseas Decoration Building, #122 Zhenhua RD., Futian, Shenzhen, China



AVR4018: Inertial Two (ATAVRSBIN2) Hardware User's Guide

Features

- Compatible with all Atmel® AVR® Xplain MCU boards
- Full nine-degree-of-freedom inertial sensing
- InvenSense three-axis MEMS gyroscope (IMU-3000™)
- Kionix® three-axis MEMS accelerometer (KXTF9)
- Honeywell three-axis electronic compass (HMC5883)
- All sensor drivers available within the Atmel AVR Software Framework
- Temperature sensing through IMU-3000

1 Introduction

The Atmel Sensors Xplained series of development boards and software are designed to be plug compatible with all Atmel Xplain MCU boards, providing a wide range of microcontroller performance depending on the application needs.

Atmel has partnered with leading suppliers of accelerometer, gyroscope, compass, pressure, and light sensors to provide a range of sensor boards that enable easy evaluation and development with a wide range of Atmel controller solutions.

To accelerate development with these sensor-based solutions, Atmel has worked with its partners to make the necessary sensor drivers available as part of the Atmel AVR Studio® development environment and the AVR Software Framework. The drivers are available directly from Atmel, and provide basic interface functionality with both raw data and calibrated engineering units outputs integrated into a standard API.

The Atmel Inertial Two Sensors Xplained development board delivers a full nine-degree-of-freedom sensor platform—combining an accelerometer, compass, gyroscope, and temperature sensing—that is ideal for developing motion sensing or user interface applications.



8-bit **AVR**[®]
Microcontrollers

Application Note

Rev. 8369A-AVR-01/11





2 Related items

2.1 Application notes

- Sensors Xplained – Software Users Guide (AVR4016)
- Sensors Xplained – Atmel Data Visualizer (AVR4017)
- Sensors Xplained – Sensor Top Board Design Notes (AVR4014)

3 Description

The Atmel Inertial Two Sensors Xplained development board provides full nine-degree-of-freedom sensing capability from a set of three integrated, three-axis inertial sensors. The sensors are connected via the I²C serial digital interface through a common header that is compatible with the full range of Atmel Xplain MCU boards. This sensor cluster is well suited for cell phones, handheld devices, computer peripherals, man-machine interfaces, virtual reality features, and game controllers.

The sensors described in the following sections are incorporated into this development board, and detailed explanations of their operation can be obtained from the relevant partner's component datasheets.

3.1 Three-axis gyroscope from InvenSense (IMU-3000)

The InvenSense IMU-3000 is a single-chip, digital-output, three-axis MEMS gyroscope IC and Digital Motion Processor™ hardware accelerator engine with a secondary I²C port that interfaces to the digital accelerometer to deliver a complete six-axis sensor fusion output to its primary I²C port. By providing an integrated sensor fusion output, the IMU-3000 offloads the intensive motion processing computation requirements from the host processor, reducing the need for frequent polling of the motion sensor output.

3.2 Three-axis accelerometer from Kionix (KXTF9-1026)

The Kionix KXTF9 is a three-axis ±2g, ±4g, or ±8g MEMS accelerometer with integrated orientation, tap/double tap, and activity detecting algorithms. An internal ASIC device packaged with the sense element provides signal conditioning and intelligent user programmable application algorithms. An I²C interface is used to communicate with the chip to configure and check updates to the orientation, Directional Tap™ detection, and activity monitoring algorithms.

3.3 Three-axis electronic compass from Honeywell (HMC5883L)

The Honeywell HMC5883L is a three-axis magnetic sensor that includes Honeywell's state-of-the-art, high-resolution, magneto-resistive sensors with automatic degaussing (demagnetizing) strap drivers, offset cancellation, and a 12-bit ADC for high-resolution earth field sensing. Utilizing Honeywell's anisotropic magneto-resistive (AMR) technology, the solid-state HMC5883L feature advanced, precision, in-axis sensitivity and linearity, and is designed to measure both the direction and the magnitude of the Earth's magnetic fields.

4 Hardware layout

Figure 4-1 shows the physical arrangement of the Inertial Two Sensors Xplained development board. Note that all three sensors have their X, Y, and Z axis aligned, and a symbol is provided to indicate their directional alignment.

Figure 4-1. Sensor arrangement.

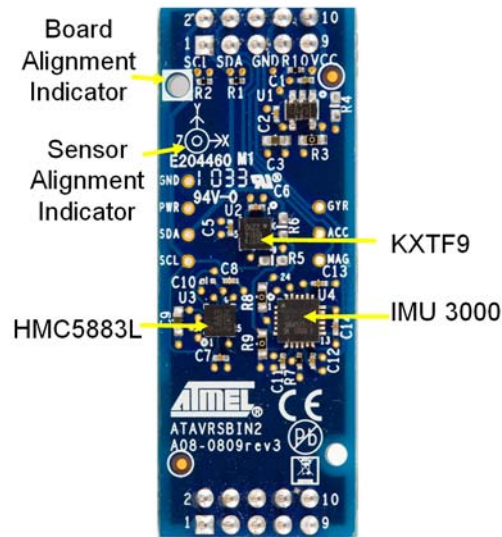

The Inertial Two Sensors Xplained development board must be attached to the correct headers on the Xplain MCU board to ensure proper operation. All the Sensors Xplained development boards attach to headers J1 and J2 on the MCU boards, and a board alignment indicator is printed on the board to aid correct alignment. As an example, Figure 4-2 shows the orientation of the similar Atmel Inertial One Sensors Xplained development board when attached to the Atmel UC3-L0 Xplained MCU board.

Figure 4-2. Correct board attachment orientation.

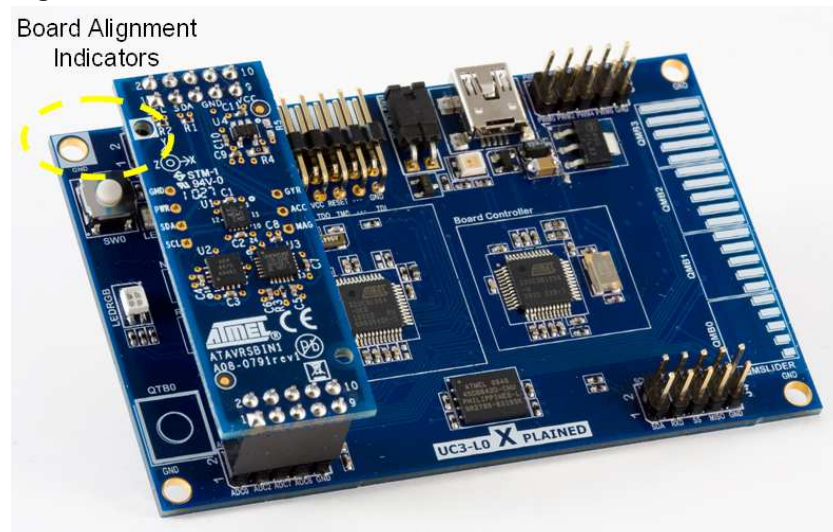

5 Schematic

Figure 5-1 shows the schematic for the Inertial Two Sensors Xplained development board, and Table 5-1 gives the I²C addresses for the three sensors.

NOTE

The I²C pull-up resistors are included on the Inertial Two Sensors Xplained board.

Figure 5-1. Inertial Two schematic.

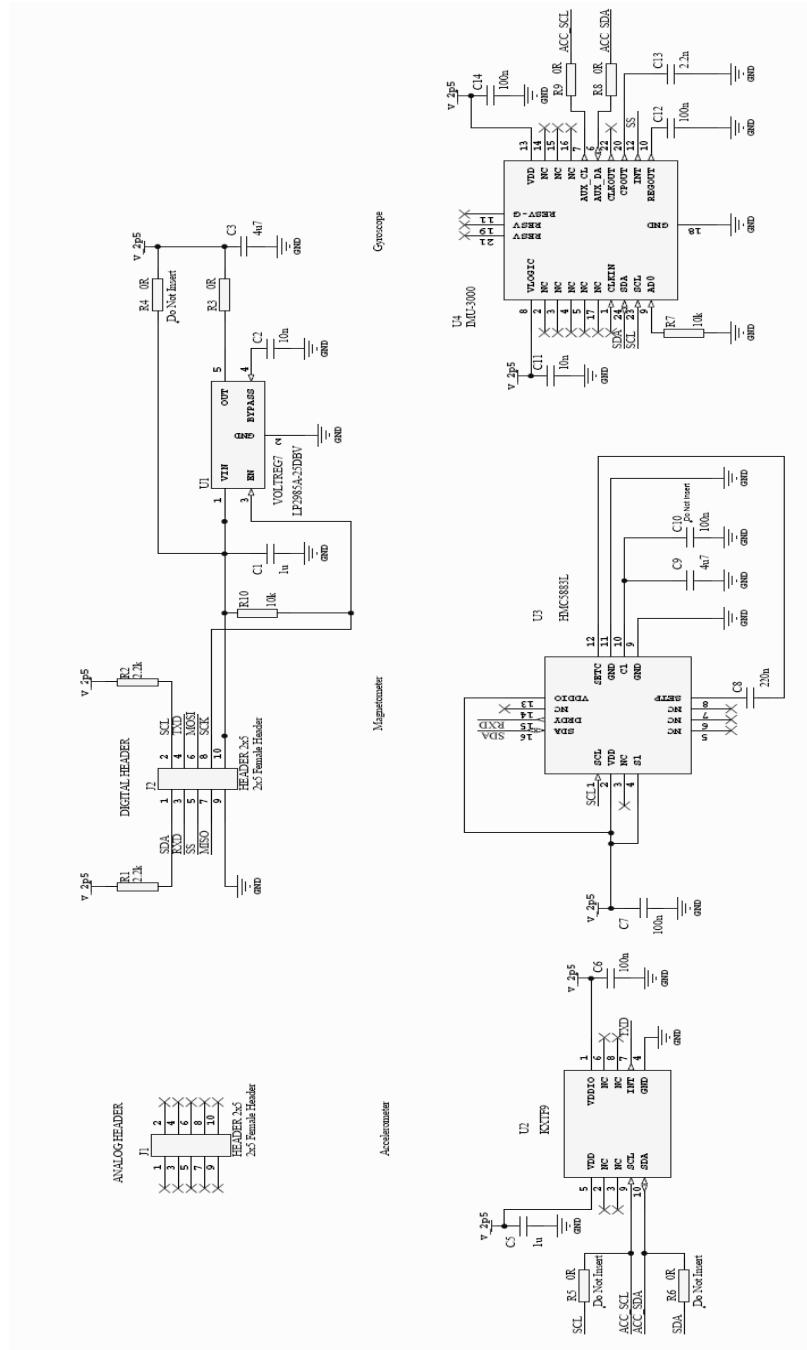

Table 5-1. Sensor I²C addresses.

Sensor	I ² C addresses
IMU-3000	0x68
KXTF9	0x0F
HMC5883L	0x1E

5.1 Circuit configuration options

A number of hardware options are available on the Inertial Two Sensors Xplained development board to allow investigation of the sensors' functioning. These options are described below.

5.1.1 Power supply options

The power supplied to the digital header on the Xplained series of sensor boards is nominally set to 3.3V. The Inertial Two Sensors Xplained development board has an onboard 2.5V regulator to supply power to all three sensors. The current from the regulator is supplied to the sensors through R3, a zero-ohm resistor. This resistor can be removed and replaced with a current monitor, if required, to investigate the sensor power consumption. If it is desired to bypass the onboard regulator, R3 can be removed and a zero-ohm resistor placed in position R4. This will now supply the sensors directly from the 3.3V Xplain MCU board supply.

5.1.2 Test points

A number of test points are available for use with an oscilloscope to investigate the functioning of the sensors. [Figure 5-2](#) shows the physical locations of the test points on the board.

Figure 5-2. Locations of test points.

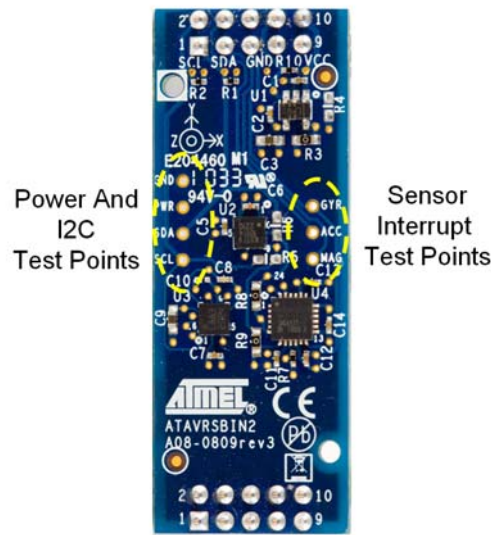



5.1.3 I²C options

In the as-shipped configuration, the KXTF9 accelerometer is connected to the auxiliary I²C bus that is controlled by the IMU-3000 gyroscope. The IMU-3000 will pass data from the primary I²C bus directly through to the KXTF9. This allows the Digital Motion Processor in the IMU-3000 to directly control the KXTF9. See the IMU-3000 datasheet for further details on this feature. If it is desired to connect the KXTF9 directly to the MCU I²C data bus, remove the two zero-ohm resistors, R8 and R9, and insert them into positions R5 and R6. This will then bypass the IMU-3000 and allow direct control of the KXTF9.

5.1.4 Regulator power control

In normal operation, the Regulator Enable input on the voltage regulator is pulled up by resistor R10. This pull-up is controlled by pin 8 on the J2 digital header, which is normally in high-impedance mode. If it is desired to power cycle the sensor board, switch pin 8 to ground. This will disable the regulator and turn off all the sensors.

EVALUATION BOARD/KIT IMPORTANT NOTICE

This evaluation board/kit is intended for use for **FURTHER ENGINEERING, DEVELOPMENT, DEMONSTRATION, OR EVALUATION PURPOSES ONLY**. It is not a finished product and may not (yet) comply with some or any technical or legal requirements that are applicable to finished products, including, without limitation, directives regarding electromagnetic compatibility, recycling (WEEE), FCC, CE or UL (except as may be otherwise noted on the board/kit). Atmel supplied this board/kit "AS IS," without any warranties, with all faults, at the buyer's and further users' sole risk. The user assumes all responsibility and liability for proper and safe handling of the goods. Further, the user indemnifies Atmel from all claims arising from the handling or use of the goods. Due to the open construction of the product, it is the user's responsibility to take any and all appropriate precautions with regard to electrostatic discharge and any other technical or legal concerns.

EXCEPT TO THE EXTENT OF THE INDEMNITY SET FORTH ABOVE, NEITHER USER NOR ATMEL SHALL BE LIABLE TO EACH OTHER FOR ANY INDIRECT, SPECIAL, INCIDENTAL, OR CONSEQUENTIAL DAMAGES.

No license is granted under any patent right or other intellectual property right of Atmel covering or relating to any machine, process, or combination in which such Atmel products or services might be or are used.

Mailing Address: Atmel Corporation, 2325 Orchard Parkway, San Jose, CA 95131





Atmel Corporation
2325 Orchard Parkway
San Jose, CA 95131
USA
Tel: (+1)(408) 441-0311
Fax: (+1)(408) 487-2600
www.atmel.com

Atmel Asia Limited
Unit 01-5 & 16, 19F
BEA Tower, Millennium City 5
418 Kwun Tong Road
Kwun Tong, Kowloon
HONG KONG
Tel: (+852) 2245-6100
Fax: (+852) 2722-1369

Atmel Munich GmbH
Business Campus
Parking 4
D-85748 Garching b. Munich
GERMANY
Tel: (+49) 89-31970-0
Fax: (+49) 89-3194621

Atmel Japan
9F, Tonetsu Shinkawa Bldg.
1-24-8 Shinkawa
Chou-ku, Tokyo 104-0033
JAPAN
Tel: (+81) 3523-3551
Fax: (+81) 3523-7581

© 2011 Atmel Corporation. All rights reserved. / Rev.: CORP072610

Atmel®, Atmel logo and combinations thereof, AVR®, AVR® logo, and others are registered trademarks or trademarks of Atmel Corporation or its subsidiaries. Other terms and product names may be trademarks of others.

Disclaimer: The information in this document is provided in connection with Atmel products. No license, express or implied, by estoppel or otherwise, to any intellectual property right is granted by this document or in connection with the sale of Atmel products. **EXCEPT AS SET FORTH IN THE ATMEL TERMS AND CONDITIONS OF SALES LOCATED ON THE ATMEL WEBSITE, ATMEL ASSUMES NO LIABILITY WHATSOEVER AND DISCLAIMS ANY EXPRESS, IMPLIED OR STATUTORY WARRANTY RELATING TO ITS PRODUCTS INCLUDING, BUT NOT LIMITED TO, THE IMPLIED WARRANTY OF MERCHANTABILITY, FITNESS FOR A PARTICULAR PURPOSE, OR NON-INFRINGEMENT. IN NO EVENT SHALL ATMEL BE LIABLE FOR ANY DIRECT, INDIRECT, CONSEQUENTIAL, PUNITIVE, SPECIAL OR INCIDENTAL DAMAGES (INCLUDING, WITHOUT LIMITATION, DAMAGES FOR LOSS AND PROFITS, BUSINESS INTERRUPTION, OR LOSS OF INFORMATION) ARISING OUT OF THE USE OR INABILITY TO USE THIS DOCUMENT, EVEN IF ATMEL HAS BEEN ADVISED OF THE POSSIBILITY OF SUCH DAMAGES.** Atmel makes no representations or warranties with respect to the accuracy or completeness of the contents of this document and reserves the right to make changes to specifications and product descriptions at any time without notice. Atmel does not make any commitment to update the information contained herein. Unless specifically provided otherwise, Atmel products are not suitable for, and shall not be used in, automotive applications. Atmel products are not intended, authorized, or warranted for use as components in applications intended to support or sustain life.