



Chipsmall Limited consists of a professional team with an average of over 10 year of expertise in the distribution of electronic components. Based in Hongkong, we have already established firm and mutual-benefit business relationships with customers from,Europe,America and south Asia,supplying obsolete and hard-to-find components to meet their specific needs.

With the principle of “Quality Parts,Customers Priority,Honest Operation,and Considerate Service”,our business mainly focus on the distribution of electronic components. Line cards we deal with include Microchip,ALPS,ROHM,Xilinx,Pulse,ON,Everlight and Freescale. Main products comprise IC,Modules,Potentiometer,IC Socket,Relay,Connector.Our parts cover such applications as commercial,industrial, and automotives areas.

We are looking forward to setting up business relationship with you and hope to provide you with the best service and solution. Let us make a better world for our industry!



Contact us

Tel: +86-755-8981 8866 Fax: +86-755-8427 6832

Email & Skype: info@chipsmall.com Web: www.chipsmall.com

Address: A1208, Overseas Decoration Building, #122 Zhenhua RD., Futian, Shenzhen, China



Features

- **Hardware**
 - Supports Programming for Atmel AT40K/AT40KAL and AT94KAL Series of SRAM-based Programmable System Level Integration (PSLI) Devices
 - Supports ISP (In-System Programming) for Atmel AT17 Series Configuration EEPROMs
 - Built-in Clock Source with GCLK/FCLK Jumper Settings
 - Supports Modular Docking Platform for the ATDH40D FPGA Daughter Boards
 - Runs Off Portable 9V DC Power Supply or External Power
 - Supports 5.0V or 3.3V Supply
 - Designed to Work with Atmel IDS 5.0 or Above
 - Downloading for AT40K/AT17 Devices Direct from PC Parallel Port
 - Can be Used to Support FPSLIC
- **System Contents**
 - ATDH2081
25-pin Parallel to 10-pin Header Adapter
 - ATDH40Dxxx
Package-specific Daughterboard (Variable)
 - ATDH40M
Programming Motherboard
 - Standard Parallel Cable (PC Parallel Port DB25), 10-pin Header Cable, 9V DC/200 mA, 2.1 mm Center Positive Power Supply

Description

The Atmel ATDH40M prototyping system allows designers to quickly and economically evaluate Atmel's family of AT40K/AT40KAL FPGA and AT94K Field Programmable System Level Integrated Circuit (FPSLIC™) devices and Atmel's AT17 FPGA configuration memory devices. The ATDH40M board connects to any x86 PC via parallel port through a 10-pin header cable to program the AT40K/AT40KAL FPGA/AT94K FPSLIC, or through a parallel port cable to program the AT17 FPGA Configuration EEPROMs. The motherboard interfaces with various daughter boards in order to program different package footprints (see Table 1).

Table 1. Daughter Board Support List

Part Number	Description
ATDH40D84	84-pin Plastic Lead Chip Carrier
ATDH40D100	100-pin Very Thin Quad Flat Pack
ATDH40D100R	100-pin Rectangular Quad Flat Pack
ATDH40D144	144-pin Thin Quad Flat Pack
ATDH40D160	160-pin Plastic Quad Flat Pack
ATDH40D208	208-pin Plastic Quad Flat Pack
ATDH40D240	240-pin Plastic Quad Flat Pack



Programmable System Level Integration Prototyping System

ATDH40M ATDH40DXXX



The AT40K/AT40KAL FPGA devices are pin-compatible in a given package footprint across the family. See Table 2 for compatibility listings. The 208PQFP, for example, will support all AT40K family members.

FPSLIC is pin-compatible with AT40K/AT40KAL device families and is supported by the ATDH40M Prototyping System.

Table 2. Part and Package Availability Showing User I/O Counts

Package	Ordering Code	AT40K05/ AT40K05AL/ AT94K05AL	AT40K10 AT40K10AL AT94K10AL	AT40K20/ AT40K20AL	AT40K40/ AT40K40AL AT94K40AL
PC84	AJ	62	62	62	62
VQ100	AQ	78	78	-	-
RQ100	RQ	78	78	77	-
TQ144	BQ	114	114	114	114
PQ160	CQ	128	130	130	-
PQ208	DQ	128	161	161	161
BG225 ⁽¹⁾	AG	-	192	192	192
PQ240	EQ	-	192	193	193
PQ304 ⁽¹⁾	FQ	-	-	256	256
BG352 ⁽¹⁾	BG	-	-	256	289
BG432 ⁽¹⁾	CG	-	-	-	352

Note: 1. Daughtercard not available for ATDH40M.

2. Not all devices are available in all package options. Please check appropriate datasheet for a list of valid part/package combinations.

Programming Setup

Figure 1 on page 3 is the board layout of the ATDH40M motherboard. Figure 2 shows the typical daughter board. To connect the two boards together, the daughter board fits on top of the motherboard by aligning the two arrows together. The two boards will only fit one way.

Programming the AT40K FPGA Device

When SW4 and SW5 are set to up, the PSLI device can be programmed by the PC parallel interface. The ATDH40M interfaces with the PC through the 10-pin header socket H1 located on the bottom right corner. Programming the FPGA is *not* possible by using the parallel port interface on the motherboard. Located below the header H1 are the mode-select dip-switches DIP-SW1. These control the mode settings for the PSLI device (switches M0, (M1), M2). The modes directly supported by the motherboard are only Slave Serial and Master Serial. Programming the AT40K FPGA from the PC can be achieved from the IDS desktop or by using the software *downld40.exe*. Both tools accept ASCII bitstream files generated by the IDS software (.BST).

Programming the AT17 Configuration Memory Device

When SW4 is set to down and SW5 is set to up, the AT17 FPGA configuration memory can be programmed by the parallel port interface located on the top left corner. Programming the AT17 FPGA Configuration EEPROM is *not* possible by using the 10-pin header H1. Programming the AT17 FPGA Configuration EEPROM from the PC can be achieved from the IDS desktop or by using the Configurator Programming System (CPS) software supplied by the IDS software. This software accepts the ASCII bitstream files (.BST) generated by IDS.

Programming the PSLI Device Using the AT17 Configuration Memory

When SW4 is set to up and SW5 is set to down, the AT17 Configurator can program the FPGA in Master Serial. To ensure reliable system power-up, set jumper JMP1 (located below the Configurator socket). The Configurator must be programmed prior to this setup.

Troubleshooting

1. Check that the motherboard is connected to the PC either through the parallel port or through the 10-pin header.
2. Check that the motherboard has power (SW1) and the power configuration switches SW2 and SW3 are correct.
3. Make sure programming configuration switches SW4 and SW5 are correct.
4. Verify that the daughter card is inserted correctly and that it receives power.
5. Verify that the PSLI device and/or the PSLI Configurator are placed in their sockets correctly.
6. Set the mode switches before downloading to the PSLI Device.
7. Set the GCLK/FCLK jumpers before verifying PSLI logic.

Technical Support

- Check each of the items listed in the troubleshooting section.
- Contact your local Atmel Representative or Distributor who provided the PSLI board for technical support.
- Contact your local Atmel FAE (available at most sales offices).
- Contact the Atmel PSLI technical support hotline at (408) 436-4119. Hours are Monday-Friday 9:00 a.m. – 6:00 p.m. PST.
- E-mail Atmel PSLI technical support at fpga@atmel.com.
- Fax inquiries to “FPGA Tech Support” at (408) 487-2637

ATDH40M Functional Schematics

Power Supply

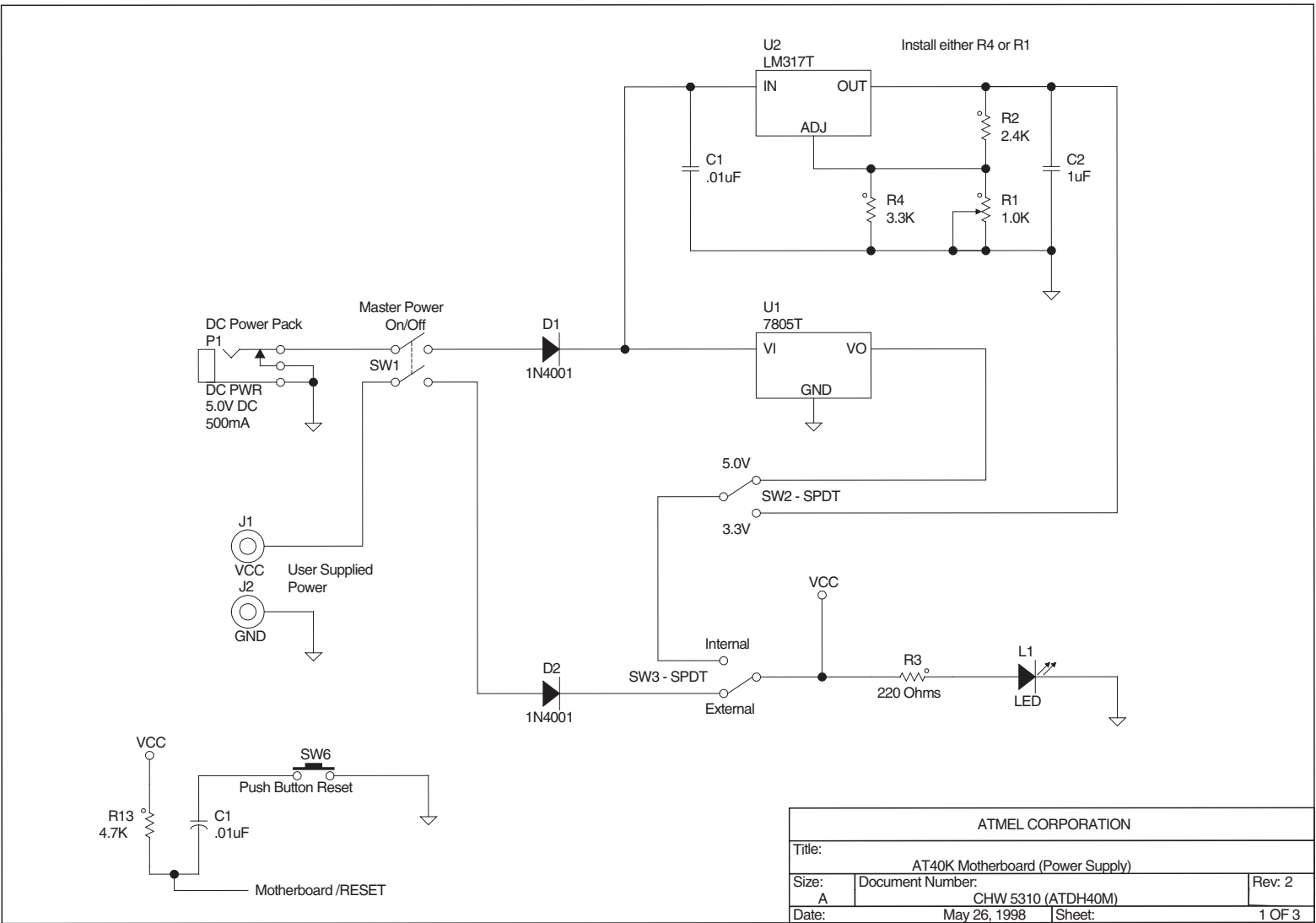

Note: The voltage regulators LM317T & 7805T allow to switch between 3.3V and 5V.

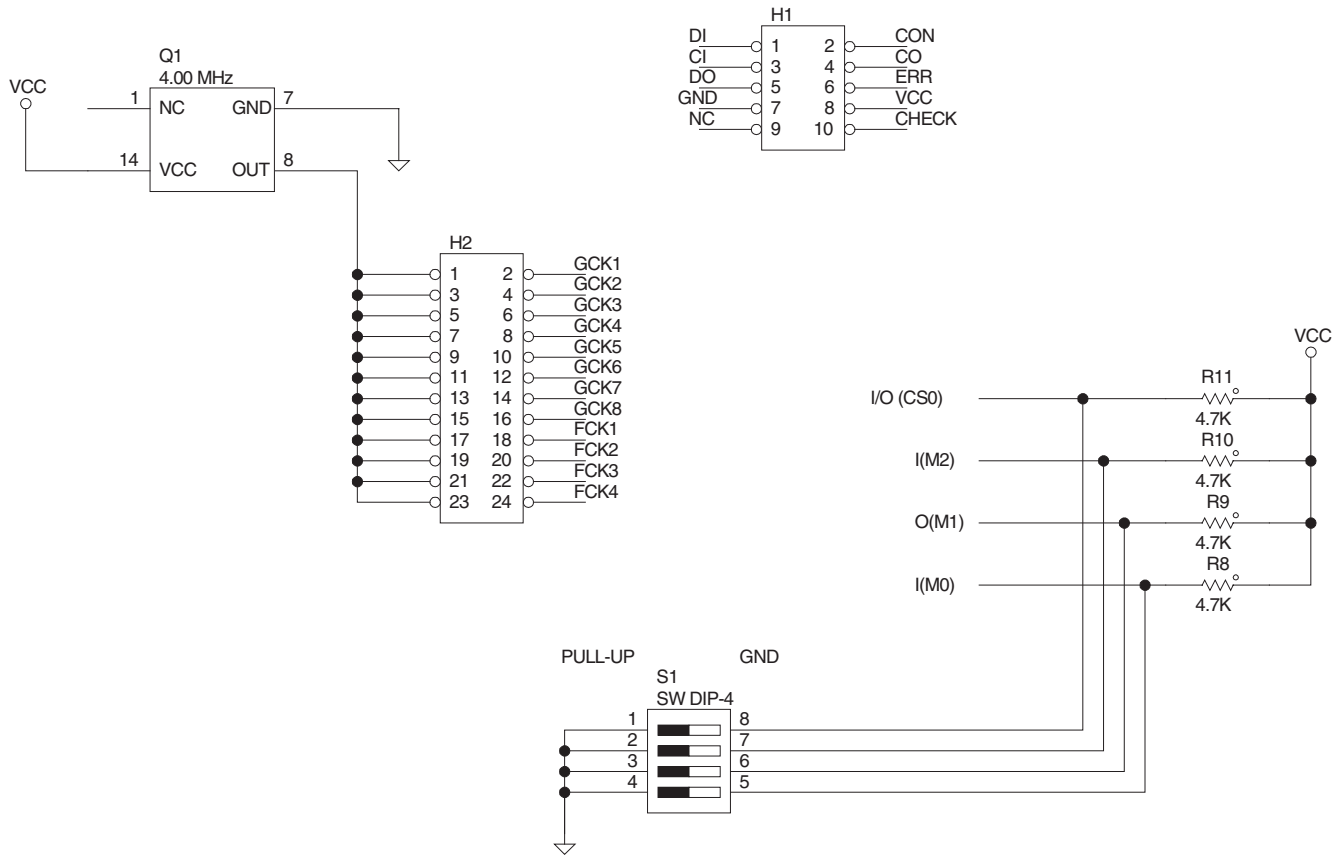

ATMEL CORPORATION		
Title: AT40K Motherboard (Mode and Clock Switches)		
Size: A	Document Number: CHW 5310 (ATDH40M)	Rev: 2
Date: May 26, 1998	Sheet:	2 OF 3

Note: The 12-pin header (H2) is used to connect the clocks with the jumpers. The DIP switch (S1) is used to set the different modes.

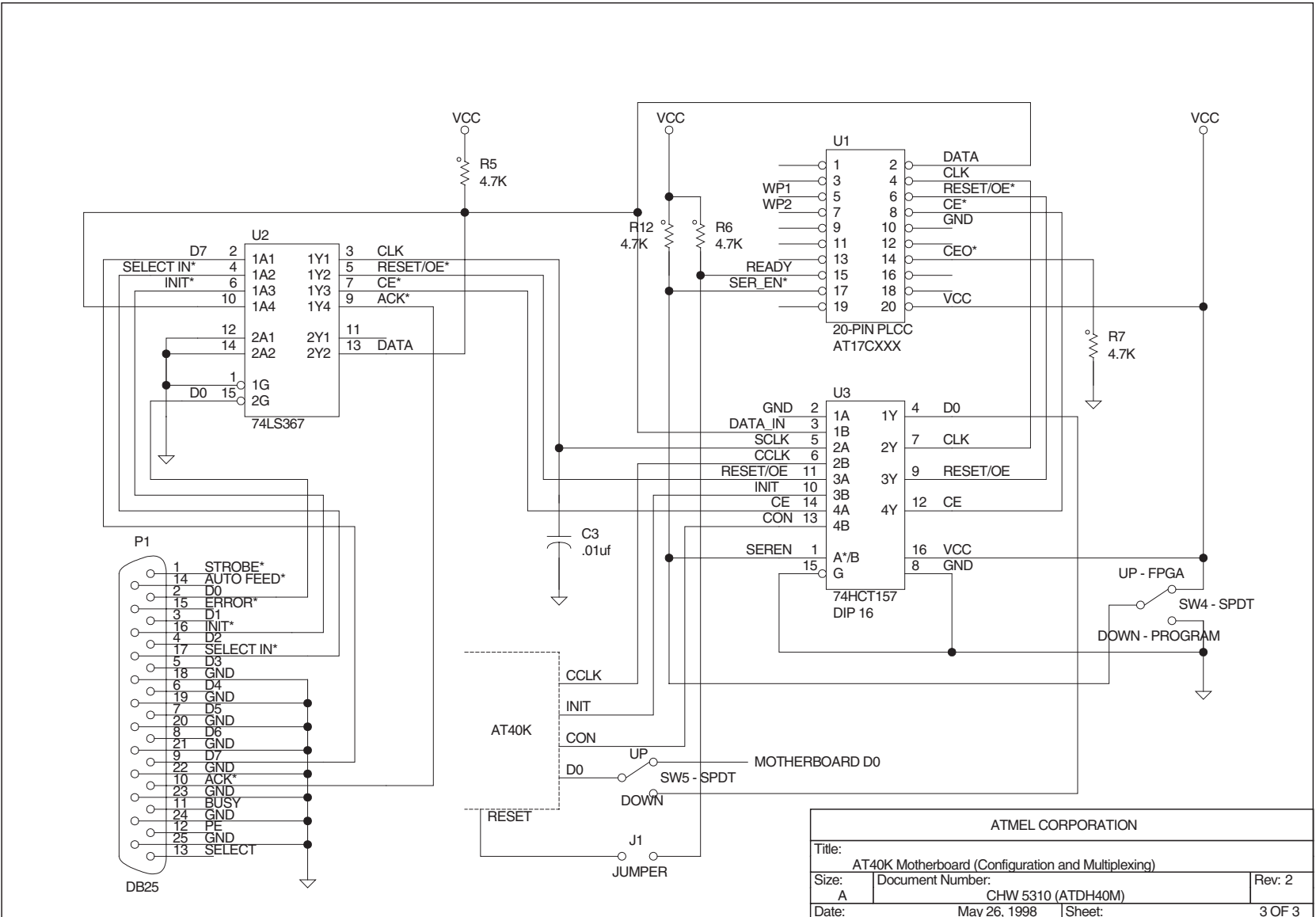

ATDH40M Layout Schematics
Configurator/Multiplexing/Buses

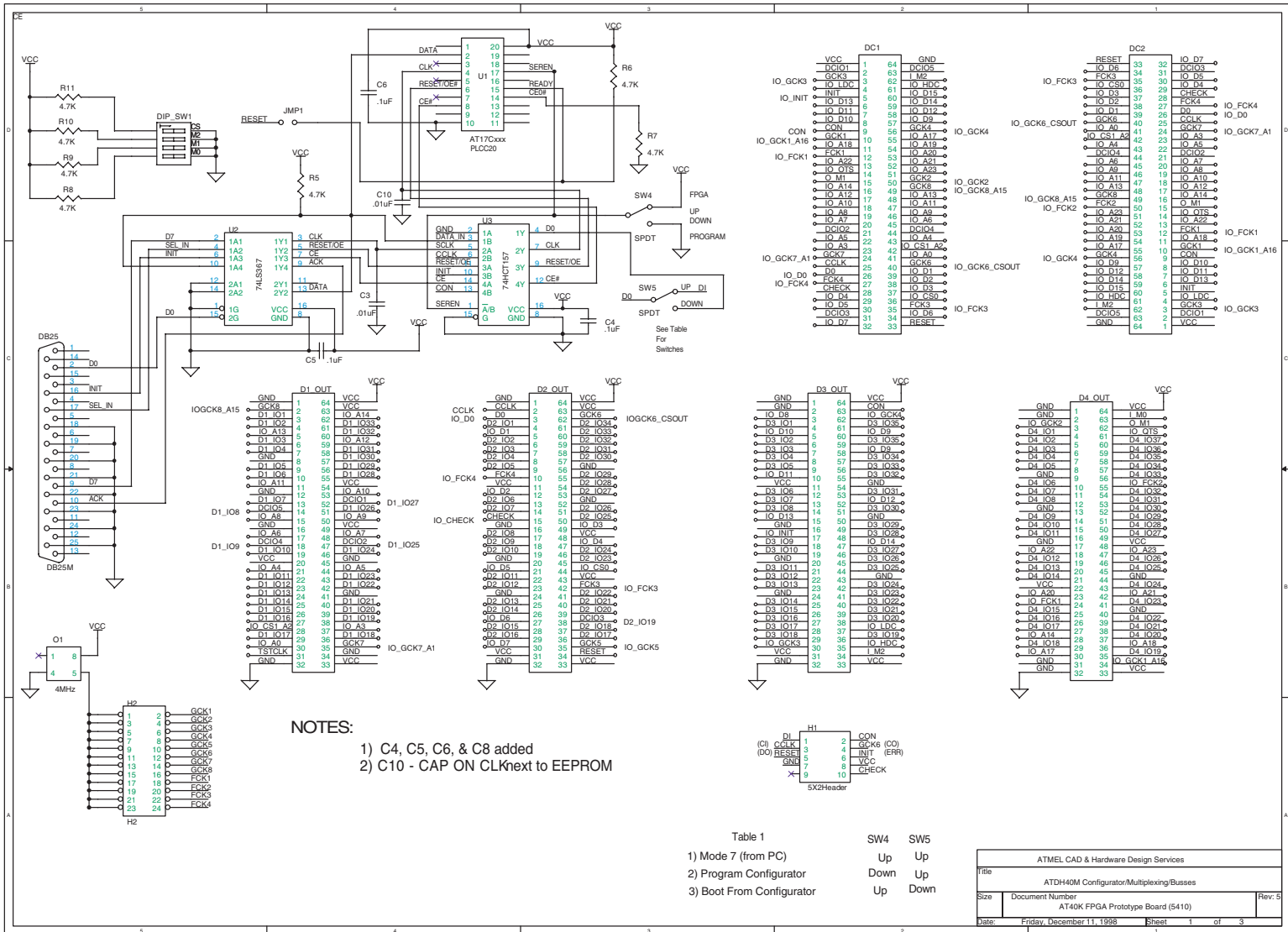

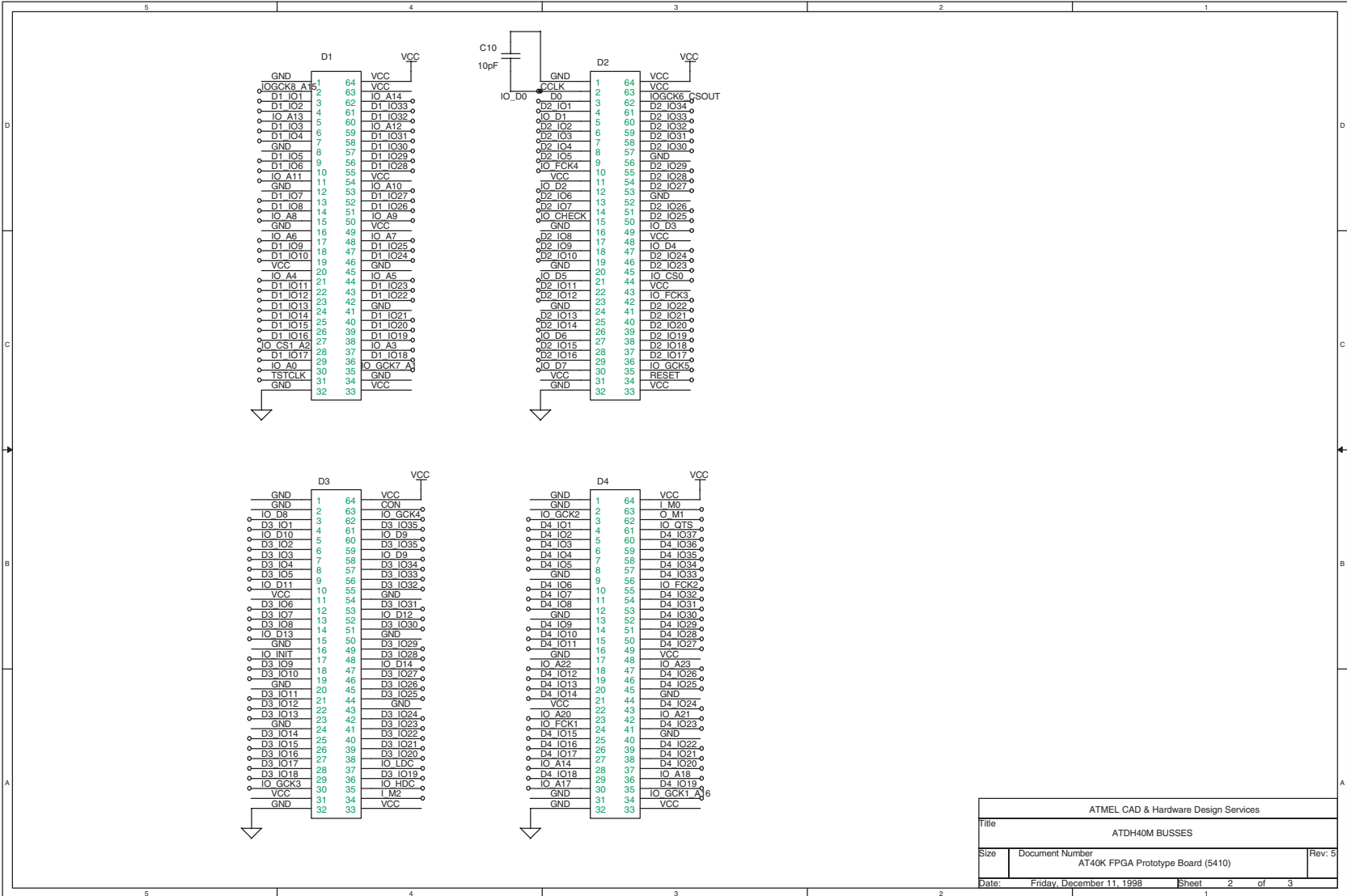

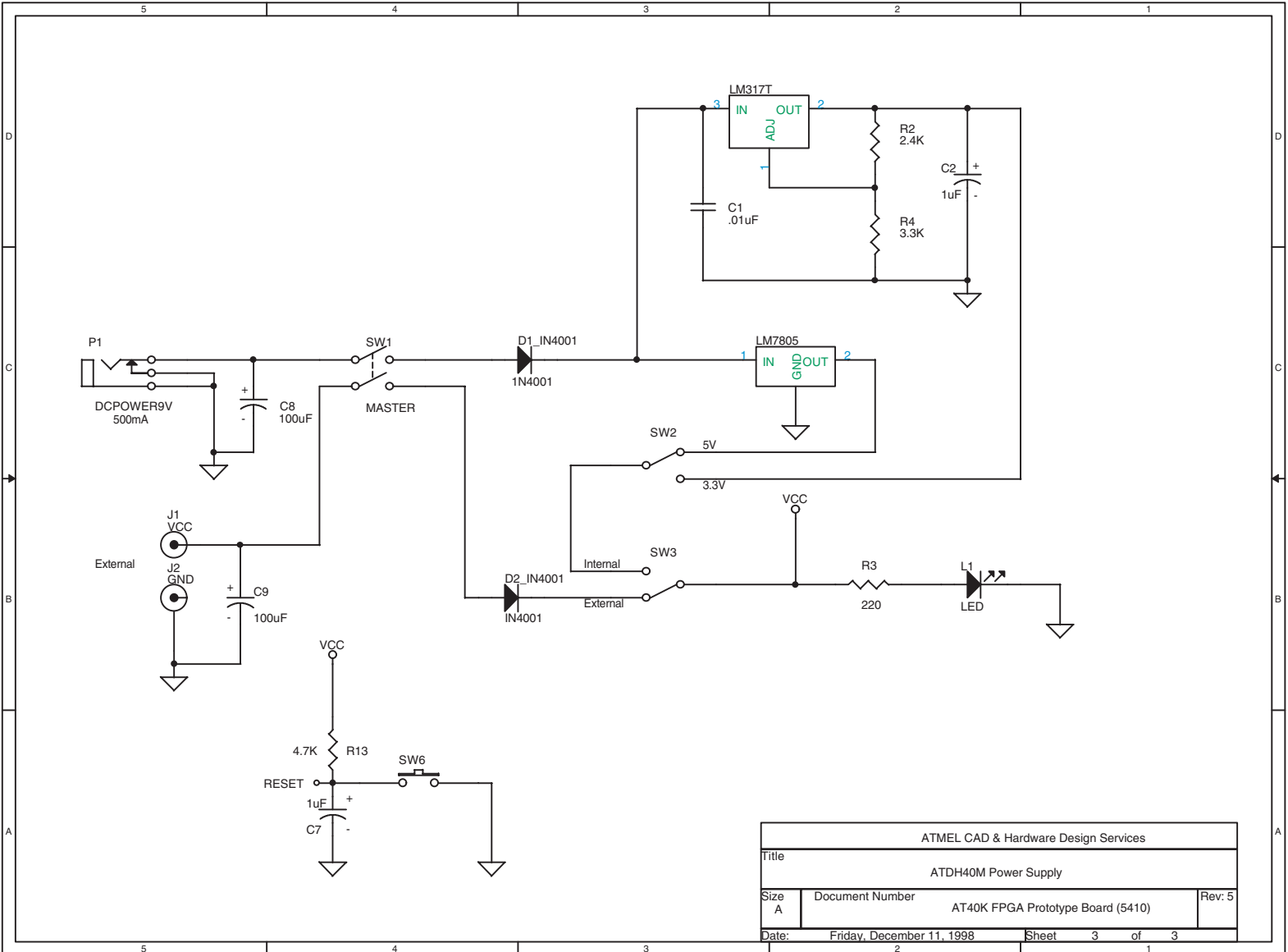

ATMEL CAD & Hardware Design Services		
Title		
ATDH40M Power Supply		
Size	Document Number	Rev: 5
A	AT40K FPGA Prototype Board (5410)	
Date:	Friday, December 11, 1998	Sheet 3 of 3
	2	1

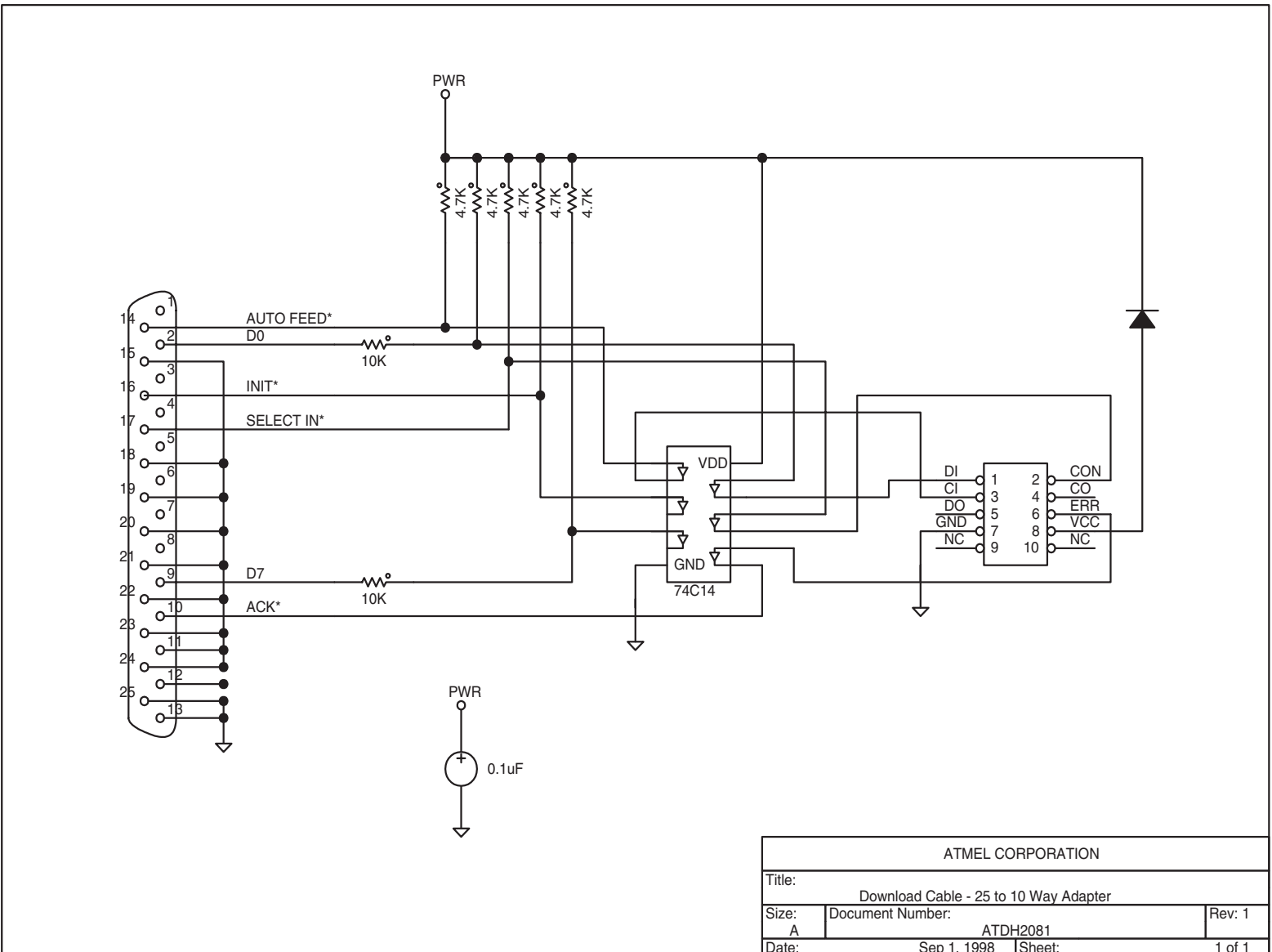

ATMEL CORPORATION		
Title: Download Cable - 25 to 10 Way Adapter		
Size: A	Document Number: ATDH2081	Rev: 1
Date: Sep 1, 1998	Sheet:	1 of 1



Atmel Headquarters

Corporate Headquarters
2325 Orchard Parkway
San Jose, CA 95131
TEL (408) 441-0311
FAX (408) 487-2600

Europe

Atmel U.K., Ltd.
Coliseum Business Centre
Riverside Way
Camberley, Surrey GU15 3YL
England
TEL (44) 1276-686-677
FAX (44) 1276-686-697

Asia

Atmel Asia, Ltd.
Room 1219
Chinachem Golden Plaza
77 Mody Road Tsimhatsui
East Kowloon
Hong Kong
TEL (852) 2721-9778
FAX (852) 2722-1369

Japan

Atmel Japan K.K.
9F, Tonetsu Shinkawa Bldg.
1-24-8 Shinkawa
Chuo-ku, Tokyo 104-0033
Japan
TEL (81) 3-3523-3551
FAX (81) 3-3523-7581

Atmel Operations

Atmel Colorado Springs
1150 E. Cheyenne Mtn. Blvd.
Colorado Springs, CO 80906
TEL (719) 576-3300
FAX (719) 540-1759

Atmel Rousset

Zone Industrielle
13106 Rousset Cedex
France
TEL (33) 4-4253-6000
FAX (33) 4-4253-6001

Atmel FPGA Hotline

1-(408) 436-4119

Atmel FPGA e-mail

fpga@atmel.com

FAQ

Available on web site

Fax-on-Demand

North America:
1-(800) 292-8635
International:
1-(408) 441-0732

e-mail

literature@atmel.com

Web Site

<http://www.atmel.com>

BBS

1-(408) 436-4309

© Atmel Corporation 2001.

Atmel Corporation makes no warranty for the use of its products, other than those expressly contained in the Company's standard warranty which is detailed in Atmel's Terms and Conditions located on the Company's web site. The Company assumes no responsibility for any errors which may appear in this document, reserves the right to change devices or specifications detailed herein at any time without notice, and does not make any commitment to update the information contained herein. No licenses to patents or other intellectual property of Atmel are granted by the Company in connection with the sale of Atmel products, expressly or by implication. Atmel's products are not authorized for use as critical components in life support devices or systems.

FPSLIC is the trademark of Atmel.

Other terms and product names may be trademarks of others.



Printed on recycled paper.

1402B-06/01/xM