



Chipsmall Limited consists of a professional team with an average of over 10 year of expertise in the distribution of electronic components. Based in Hongkong, we have already established firm and mutual-benefit business relationships with customers from,Europe,America and south Asia,supplying obsolete and hard-to-find components to meet their specific needs.

With the principle of “Quality Parts,Customers Priority,Honest Operation,and Considerate Service”,our business mainly focus on the distribution of electronic components. Line cards we deal with include Microchip,ALPS,ROHM,Xilinx,Pulse,ON,Everlight and Freescale. Main products comprise IC,Modules,Potentiometer,IC Socket,Relay,Connector.Our parts cover such applications as commercial,industrial, and automotives areas.

We are looking forward to setting up business relationship with you and hope to provide you with the best service and solution. Let us make a better world for our industry!



Contact us

Tel: +86-755-8981 8866 Fax: +86-755-8427 6832

Email & Skype: info@chipsmall.com Web: www.chipsmall.com

Address: A1208, Overseas Decoration Building, #122 Zhenhua RD., Futian, Shenzhen, China



All-in-one IC Solution for Active Antennas

DATASHEET

Features

- Highly integrated - All-in-one active antenna IC
- Integrated AGC for AM and FM
- Integrated driver for AM and FM pin diodes
- Integrated power supply regulator
- Integrated antenna sensor
- Separated AM LNA, AM buffer and FM amplifier
- High dynamic range for AM and FM
- Excellent noise performance
- High intercept point 3rd order for FM
- FM amplifier adjustable to various cable impedances
- High intercept point 2nd and 3rd order for AM
- Low noise output voltage
- Low power consumption
- Low output impedance AM
- Only small capacitor values necessary at AM AGC
- Large AM frequency range to cover DRM broadcast signals

1. Description

The Atmel® ATR4252C is a highly integrated high performance AM/FM antenna amplification IC with several features. The device has built-in AGC's for both AM and FM, antenna detection, a power supply regulator as well as additional pre-integrated peripherals.

The Atmel ATR4252C is based on BICMOS technology. The device is designed in particular for car application and is suitable for active antennas located in several positions on the car such as bumpers, windscreen, mirrors or windows.

Figure 1-1. Block Diagram

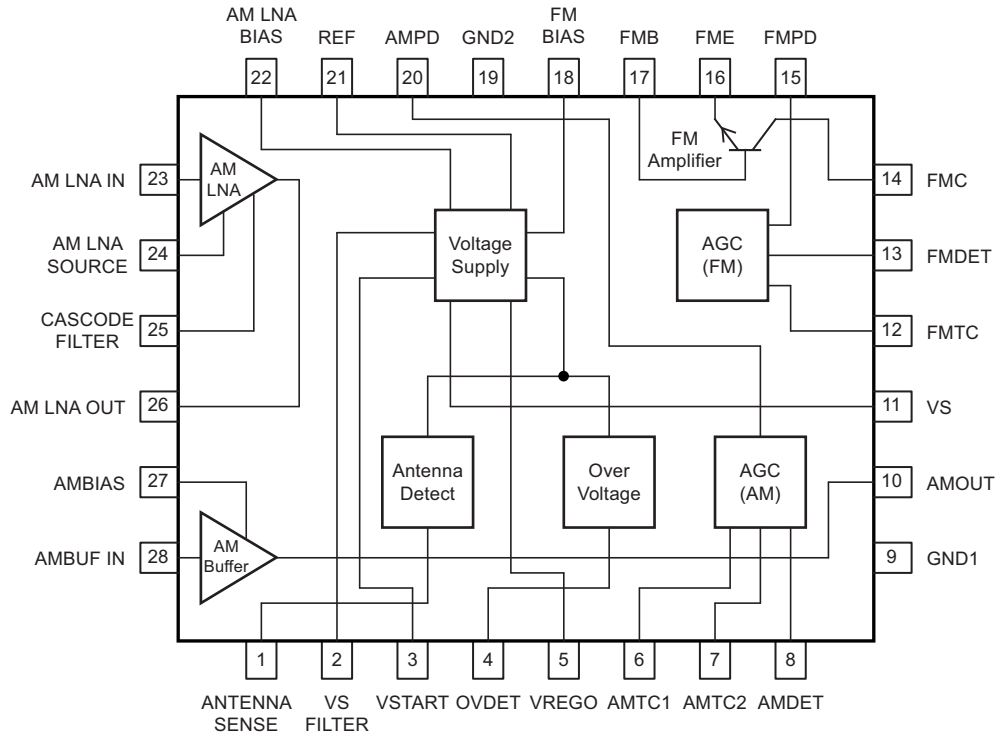

2. Pin Configuration

Figure 2-1. Pinning VQFN 4x5 / 28L

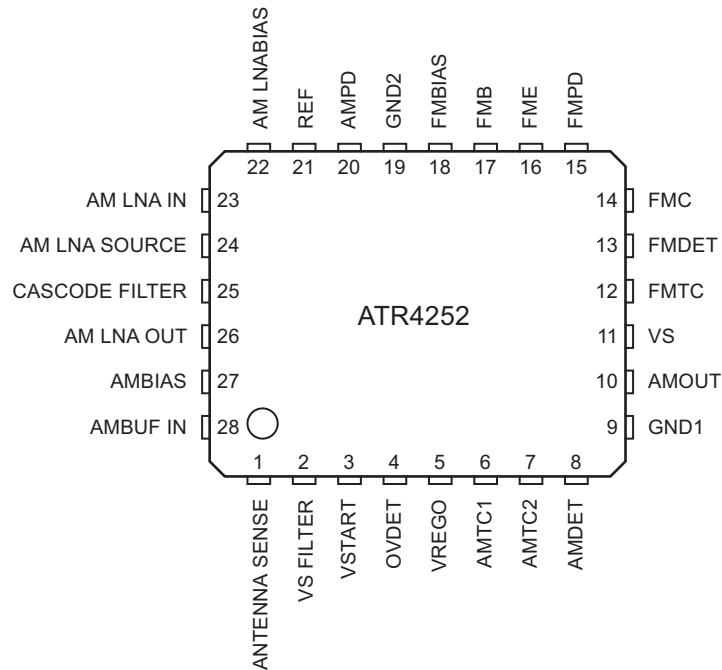

Table 2-1. Pin Description

Pin	Symbol	Function
1	ANTENNA SENSE	Antenna sense input
2	VS FILTER	Supply voltage filter input
3	VSTART	Comparator input of voltage detector
4	OVDET	Overvoltage detection input
5	VREGO	Output of voltage regulator
6	AMTC1	AM AGC time-constant capacitance 1
7	AMTC2	AM AGC time-constant capacitance 2
8	AMDET	Level detector input of AM-AGC
9	GND1	Ground AM
10	AMOUT	AM output, impedance matching
11	VS	Supply voltage
12	FMTC	FM AGC time constant
13	FMDET	Level detector input of FM-AGC
14	FMC	Collector of FM amplifier (NPN)
15	FMPD	FM AGC output for pin diode
16	FME	FM amplifier emitter (NPN)
17	FMB	FM amplifier base (NPN)
18	FMBIAS	Reference voltage 2.7V FM
19	GND2	Ground FM
20	AMPD	AM AGC output for pin diode

Table 2-1. Pin Description (Continued)

Pin	Symbol	Function
21	REF	Reference voltage 6V
22	AM LNA BIAS	Reference voltage for AM LNA IN
23	AM LNA IN	AM LNA input terminal
24	AM LNA SOURCE	AM LNA source terminal
25	CASCODE FILTER	AM Cascode filter terminal
26	AM LNA OUT	AM LNA output terminal
27	AMBIAS	Reference voltage for AMBUF IN
28	AMBUF IN	AM Buffer amplifier input, impedance matching
Paddle	GND	Ground paddle

3. Functional Description

The Atmel® ATR4252C is a highly integrated AM/FM antenna IC with lots of features and functions. In fact the most important feature is the impedance matching on both the antenna input and the cable. The Atmel ATR4252C compensates cable losses between the antenna (for example, windscreen, roof or bumper antennas) and the car radio, which is usually placed far away from the antenna.

AM means long wave (LW), medium wave (MW) and short wave (SW) frequency bands (150kHz to 30MHz) that are usually used for AM as well as for DRM transmissions, and FM means any of the world wide used frequency bands for FM radio broadcast (70MHz to 110MHz).

Two separate amplifier chains are used for AM and FM due to the different operation frequencies and requirements in the AM and FM band. This allows the use of separate antennas (e.g., windscreen antennas) for AM and FM. Of course, both amplifier chain inputs can also be connected to one antenna (e.g., roof antenna).

The AM amplifier chain is separated into two amplifiers. The first one is an LNA that is optimized for low noise figure and low input capacitance. The second amplifier (AM buffer) is optimized to drive a possibly long antenna cable with high parasitic capacitance. Both amplifiers have outstanding large signal performance. All input and output terminals of these two amplifiers are accessible from outside so they can be connected together according to the application needs. Additionally, a filter can be inserted between LNA output and buffer amplifier input.

For AM and FM amplifier chain, two separate automatic gain control (AGC) circuits have been integrated in order to avoid overdriving the amplifiers in large signal conditions. The two separate AGC loops prevent strong AM signals from blocking FM stations and vice versa.

The integrated PIN diode drivers reduce the external component cost and board space.

A voltage regulation stage is integrated in order to further reduce the external component costs. This stage provides overvoltage protection and current limitation. An external transistor is used as power driver for this stage.

3.1 AM Amplifier

Due to the long wavelength in AM bands, the antennas used for AM reception in automotive applications are short compared to the wavelength. Therefore, these antennas do not provide 50Ω output impedance, but have an output impedance of some pF. If these (passive) antennas are connected to the car radio by a long cable, the capacitive load of this cable (some 100pF) dramatically reduces the signal level at the tuner input.

In order to overcome this problem, Atmel ATR4252C provides two AM amplifiers, one LNA and one AM buffer amplifier. These two amplifiers can be used independently because all input/output terminals and bias inputs are externally accessible for the application.

The AM LNA has low input capacitance (12pF typically) to reduce the capacitive load at the antenna and provides a voltage gain of typically 9dB that can be varied from 0 to 15dB depending on external application.

The AM buffer amplifier has a very low input capacitance of typically 2.45pF and can also be connected directly to the car antenna if no additional gain is required. Due to the low output impedance of 8Ω , the buffer amplifier is perfectly suited to drive the capacitive load of long antenna cables. The voltage gain of this amplifier is close to 1 (0dB), but the insertion gain that is achieved when the buffer amplifier is inserted between antenna output and antenna cable may be much higher (up to 35dB). The actual value, of course, depends on antenna and cable capacitances.

The input of the buffer amplifier is connected by an external $4.7M\Omega$ resistor to the bias voltage in order to maintain high input impedance and low noise voltage.

AM tuners in car radios usually use PIN diode attenuators at their input. These PIN diode attenuators attenuate the signal by reducing the input impedance of the tuner. Therefore, a series resistor is used at the AM amplifier output in the standard application. This series resistor guarantees well-defined source impedance for the radio tuner and protects the output of the AM amplifier from short circuit by the PIN diode attenuator in the car radio.

3.2 AM AGC

The IC is equipped with an AM AGC capability to prevent overdriving of the amplifier in case the amplifier operates near strong signal sources, e.g., transmitters.

The AM amplifier output AMOUT is applied to a resistive voltage divider. This divided signal feeds the AGC level detector input pin AMDET. The rectified signal is compared against an internal reference. The threshold of the AGC can be adjusted by modification of the divider ratio of the external voltage divider. If the threshold is reached, the pin AMPD opens an internal transistor, which controls the pin diode current and limits the antenna signal to prevent an overdriving of the AM amplifier.

As the AM AGC has to react very slowly, large capacitors are usually needed for this time delay. To reduce the cost of the external components, a current control for the time delay is integrated, so that only small external capacitor values are needed.

The necessary driver for the external pin diode is already incorporated in the Atmel® ATR4252C IC, which reduces the BOM cost and the application size.

3.3 FM Amplifier

The FM amplifier is realized with a high performance single NPN transistor. This allows the use of an amplifier configuration, which is optimized for the desired requirements. For low cost application, the common emitter configuration provides good performance at reasonable BOM cost. For high end application, common base configuration with lossless transformer feedback provides high IP3 and low noise figure at reasonable current consumption. In both configurations, gain, input and output impedance can be adjusted by modification of external components.

The temperature compensated bias voltage (FMBIAS) for the base of the NPN transistor is derived from an integrated voltage reference. The bias current of the FM amplifier is defined by an external resistor.

3.4 FM AGC

The IC is equipped with an AGC capability to prevent overdriving of the amplifier in case the amplifier is operated at strong antenna signals, e.g., near transmitters. It is possible to realize an additional antenna amplifier path with integrated AGC and external RF transistor. The bandwidth of the integrated AGC circuit is 900MHz.

FM amplifier output FMC is connected to a capacitive voltage divider and the divided signal is applied to the AGC level detector at pin FMDET. This level detector input is optimized for low distortion. The rectified signal is compared against an internal reference. The threshold of the AGC can be adjusted by tuning the divider ratio of the external voltage divider. If the threshold is reached, pin FMPD opens an internal transistor, which controls the pin-diode current. By these means, the amplifier input signal is limited and therefore the FM amplifier is prevented from signal overdrive.

The necessary driver for the external pin diode is already incorporated in the Atmel ATR4252C IC, which reduces the BOM cost and the application size.

3.5 Supply Voltage Regulator

The driving voltage for an external power transistor is provided by an integrated regulator circuit.

An overvoltage protection circuit recognizes overvoltage condition and switches off the amplifier and AGC circuits in order to reduce current consumption and avoid thermal overload.

3.6 Antenna Sensor

In addition, an antenna sensor has been integrated in order to recognize if the antenna is properly connected to the amplifier module. If no antenna is detected, the amplifier and AGC circuits are switched off in order to signal this error via reduction of supply current consumption to the unit that provides and monitors the supply current for the antenna amplifier (e.g., the car radio).

4. Absolute Maximum Ratings

Stresses beyond those listed under “Absolute Maximum Ratings” may cause permanent damage to the device. This is a stress rating only and functional operation of the device at these or any other conditions beyond those indicated in the operational sections of this specification is not implied. Exposure to absolute maximum rating conditions for extended periods may affect device reliability.

Reference point is ground.

Parameters	Pin	Symbol	Min.	Max.	Unit
Supply voltage	11	V_S	-0.3	+12	V
Antenna sense current	1	ANTENNA SENSE	-500	+500	μ A
Comparator input current	3	VSTART	0	2	mA
Overvoltage detector	4	OVDET	-0.3	+3.3	V
Collector of FM amplifier	14	FMC	3	16	V
AM LNA input terminal	23	AM LNA IN	0	2	V
AM LNA output terminal	26	AM LNA OUT	7	12	V
Power dissipation		P_{tot}		1200	mW
Junction temperature		T_j		150	$^{\circ}$ C
Ambient temperature		T_{amb}	-40	+105	$^{\circ}$ C
Storage temperature		T_{stg}	-50	+150	$^{\circ}$ C
ESD HBM	all	V_{HBM}	-2	+2	kV

5. Thermal Resistance

Parameters	Symbol	Value	Unit
Junction ambient, soldered on PCB, dependent on PCB layout	R_{thJA}	40	K/W

6. Operating Range

Parameters	Test Conditions	Pin	Symbol	Min.	Typ.	Max.	Unit
Supply voltage	Normal operation	11	V_S	7.5	10	11	V
Supply voltage	No malfunction, performance may be reduced	11	V_S	7		11	V

7. Electrical Characteristics

See test circuit [Figure 8-2 on page 13](#), $V_S = 10V$, $T_{amb} = 25^\circ C$, unless otherwise specified

No.	Parameters	Test Conditions	Pin	Symbol	Min.	Typ.	Max.	Unit	Type*
1.1	Supply current	AGC OFF	VS, FMC, AM LNA OUT	Is		77		mA	B
		FMAGC ON	VS, FMC, AM LNA OUT	Is		85	95	mA	B
		Antenna sense error detected	VS, FMC, AM LNA OUT	Is	15	20	25	mA	A
		Over voltage	VS, FMC, AM LNA OUT	Is		12	14.9	mA	A
		$T_{amb} = -40$ to $+105^\circ C$; FMAGC ON	VS, FMC, AM LNA OUT	Is			99	mA	C
1.2	Reference voltage output	Includes an U_{be} -Drift	FM BIAS	V_{FMBIAS}	2.2	2.7	3.2	V	A
1.3	Output current of reference voltage		FM BIAS	I_{FMBIAS}	0		3	mA	B
1.4	Reference voltage output		AM BIAS	V_{AMBIAS}		0.32 V_S		V	A
1.5		1k Ω load resistor	REF	V_{REF}	5.7	6	6.3	V	A
1.6			AM LNA BIAS	$V_{AMLNABIAS}$		2.8		V	A
2	AM LNA+ Buffer⁽²⁾								
2.1	Input capacitance	f = 1MHz	AM LNA IN	$C_{AMLNAIN}$		12		pF	C
2.2	Input leakage current	$T_{amb} = 105^\circ C$	AM LNA IN	$I_{AMLNAIN}$			40	nA	C
2.3	Supply current AM- LNA		AM LNA OUT	$I_{AMLNAOUT}$		18		mA	A
2.4	Voltage gain	f = 1 MHz	AM/FM-OUT			9		dB	B
2.5	Input noise voltage	Buffer OUT, $R_{BIAS} = 4.7M\Omega$, B = 9kHz, f = 500kHz, f = 1MHz	Antenna Dummy Input	V_{N1}		-9		dB μ V	C
				V_{N2}		-12		dB μ V	C
2.7	Maximum operating frequency	3dB corner	AM/FM-OUT		30			MHz	C
2.8	OIP3 ⁽¹⁾	AM/FM Out; $f_{inp} = 1MHz + 1.1MHz$, $V_{out} = 110dB\mu V$, 1K 500pF load, $V_S = 10V$				144		dB μ V	C
		$V_S = 7.5V$				140		dB μ V	C
2.9	OIP2 ⁽¹⁾	AM/FM Out; $f_{inp} = 1MHz + 1.1MHz$, $V_{out} = 110dB\mu V$, 1K 500pF load, $V_S = 10V$				170		dB μ V	C
		$V_S = 7.5V$				157		dB μ V	C

*) Type means: A = 100% tested, B = 100% correlation tested, C = Characterized on samples, D = Design parameter

- Notes:
1. AGC loop deactivated (PIN diode removed)
 2. Measured with antenna dummy (see [Figure 8-3 on page 14](#)).
 3. Current defined by $R17 = 56\Omega$

7. Electrical Characteristics (Continued)

See test circuit [Figure 8-2 on page 13](#), $V_S = 10V$, $T_{amb} = 25^\circ C$, unless otherwise specified

No.	Parameters	Test Conditions	Pin	Symbol	Min.	Typ.	Max.	Unit	Type*
3 AM Buffer Amplifier ⁽²⁾									
3.1	Input capacitance	f = 1MHz	AM BUF IN	C_{AMIN}	2.2	2.45	2.7	pF	C
3.2	Input leakage current	$T_{amb} = 85^\circ C$	AM BUF IN				40	nA	C
3.3	Output resistance		AM OUT	R_{OUT}	6	8	10	Ω	C
3.4	Voltage gain	f = 1MHz			0.85	0.90	0.96		A
3.5	Output noise voltage	AMOUT, $R_{BIAS} = 4.7M\Omega$, B = 9kHz, 150kHz 200kHz 500kHz 1MHz	AM OUT	V_{NOISE}		-8 -9 -11 -12	-6 -7 -9 -10	dB μ V dB μ V dB μ V dB μ V	C
3.6	OIP3 ⁽¹⁾	AM/FM Out; $f_{inp} = 1MHz + 1.1MHz$, $V_{out} = 110dB\mu V$, 1K 500pF load, $V_S = 10V$					145	dB μ V	C
		$V_S = 7.5V$				142	dB μ V	C	
3.7	OIP2 ⁽¹⁾	AM/FM Out; $f_{inp} = 1MHz + 1.1MHz$, $V_{out} = 110dB\mu V$, 1K 500pF load, $V_S = 10V$					173	dB μ V	C
		$V_S = 7.5V$				162	dB μ V	C	
3.8	Maximum operating frequency	0.5dB corner	AM OUT		30			MHz	C
4 AM AGC									
4.1	Input resistance		AM DET	R_{AMDET}	40	50		k Ω	A
4.2	Input capacitance	f = 1MHz	AM DET	C_{AMDET}	2.6	3.2	3.8	pF	C
4.3	AGC input voltage threshold	f = 1MHz	AM DET	V_{AMth}	86	89	92	dB μ V	B
4.4	3dB corner frequency	AGC threshold increased by 3dB	AM PD		30			MHz	C
4.5	Saturation voltage	10mA	AM PD			VS - 1.9		V	B
4.6	Leakage current		AM PD				4	μ A	B
4.7	Maximum PIN Diode current	AGC active	AM PD		22	35		mA	A
4.8	Maximum AGC sink current	$V(AMTC1) = 2V$ R _{off}	AM PD	I_{AMSink}	-2.0	-1.7	-1.4	μ A	A
4.9	Transconductance of level detector	diamtc1 / duamdet	am det, am tc1	$\frac{di_{amtc}}{du_{amdet}}$		60		$\frac{\mu A}{V_{rms}}$	B
4.10	IP3 at level detector input	1MHz + 1.1MHz, 120dB μ V	AM DET		150	170		dB μ V	C

*) Type means: A = 100% tested, B = 100% correlation tested, C = Characterized on samples, D = Design parameter

- Notes:
1. AGC loop deactivated (PIN diode removed)
 2. Measured with antenna dummy (see [Figure 8-3 on page 14](#)).
 3. Current defined by R17 = 56 Ω

7. Electrical Characteristics (Continued)

See test circuit [Figure 8-2 on page 13](#), $V_S = 10V$, $T_{amb} = 25^\circ C$, unless otherwise specified

No.	Parameters	Test Conditions	Pin	Symbol	Min.	Typ.	Max.	Unit	Type*
5 FM Amplifier (see Figure 8-1 on page 12)									
5.1	Emitter voltage	$T = 25^\circ C$	FME		1.85	1.95	2.3	V	A
5.2	Emitter voltage	$T = -40^\circ C$ to $+105^\circ C$	FME		1.7		2.3	V	C
5.3	Supply current	Common base	FMC	I_{FMC}		29		mA	B
5.4	Supply current ⁽³⁾	Common emitter	FMC	I_{FMC}		35		mA	A
5.5	Maximum output voltage	$V_S = 10V$	FMC		12			V_{pp}	C
5.6	Input resistance	$f = 100MHz$	FM IN	R_{FMIN}		50		Ω	C
5.7	Maximum operating frequency	3dB corner, common emitter	FM OUT		450			MHz	C
5.8	Output resistance	$f = 100MHz$	FM OUT	R_{FMOUT}		50		Ω	C
5.9	Power gain	$f = 100MHz$, common base circuit (see Figure 8-2 on page 13)		G		5.2		dB	C
5.10	OIP3 at FMOUT	Common base circuit	FM OUT			145		dB μV	C
5.11	NF	Common base circuit				1.9		dB	C
5.12	Power gain	$f = 100MHz$, common emitter circuit (see Figure 8-1 on page 12)		G		13.5		dB	B
5.13	OIP3 at FMOUT	Common emitter circuit	FM OUT			140		dB μV	B
5.14	NF	Common emitter circuit	FM OUT			3.5		dB	C
6 FM AGC									
6.1	AGC input voltage threshold	FM range: $f = 100MHz$ Extended: $f = 900MHz$	FM DET	$V_{th1,100}$ $V_{th1,900}$	83 81	85 85	87 89	dB μV dB μV	B C
6.2	Saturation voltage	10mA	FMPD			$V_S - 1.9$		V	B
6.3	Leakage current		FMPD				1	μA	B
6.4	Maximum PIN Diode current	AGC active	FMPD		12	14		mA	A
6.5	Input resistance		FM DET	R_{FMDET}	17	21	25	k Ω	C
6.6	Input capacitance	$f = 100MHz$	FM DET	C_{FMDET}	1.5	1.75	2.0	pF	C
6.7	IP3 Pin 13 FM	100MHz + 105MHz, VFMDDET = 120dB μV	FM DET			150		dB μV	C
6.8	Current Pin FMTC	RFOff	FMTC	I_{FMTC}	-13	-9	-7.2	μA	C
6.9	Transconductance	dI_{FMTC} / dU_{FMDET}	FMTC FM DET	dI_{FMTC} / dU_{FMDET}	0.35	0.5	0.8	mA/V (rms)	B

*) Type means: A = 100% tested, B = 100% correlation tested, C = Characterized on samples, D = Design parameter

- Notes:
1. AGC loop deactivated (PIN diode removed)
 2. Measured with antenna dummy (see [Figure 8-3 on page 14](#)).
 3. Current defined by $R17 = 56\Omega$

7. Electrical Characteristics (Continued)

See test circuit [Figure 8-2 on page 13](#), $V_S = 10V$, $T_{amb} = 25^{\circ}C$, unless otherwise specified

No.	Parameters	Test Conditions	Pin	Symbol	Min.	Typ.	Max.	Unit	Type*
7 Voltage Regulator / Monitor									
7.1	Output voltage of regulator	Battery voltage $V_B = 14V$	VS		9.5	10	10.5	V	A
7.2	Ripple rejection of regulator	100Hz, $V_B > V_S + 1V$	VB, AM/FM-Out		40	50		dB	C
7.3	Threshold for over-voltage detection		OVDET		1.6		1.8	V	A
7.4	Hysteresis of over voltage detection		OVDET			4		%	C
8 Antenna Sensor									
8.1	Antenna monitor range	$R_{sense} = 22k\Omega$, antenna detected	ANT SENS		0 to 3		6 to 16	V	C

*) Type means: A = 100% tested, B = 100% correlation tested, C = Characterized on samples, D = Design parameter

- Notes:
1. AGC loop deactivated (PIN diode removed)
 2. Measured with antenna dummy (see [Figure 8-3 on page 14](#)).
 3. Current defined by $R17 = 56\Omega$

8. Test Circuits

Figure 8-1. Common Emitter Configuration

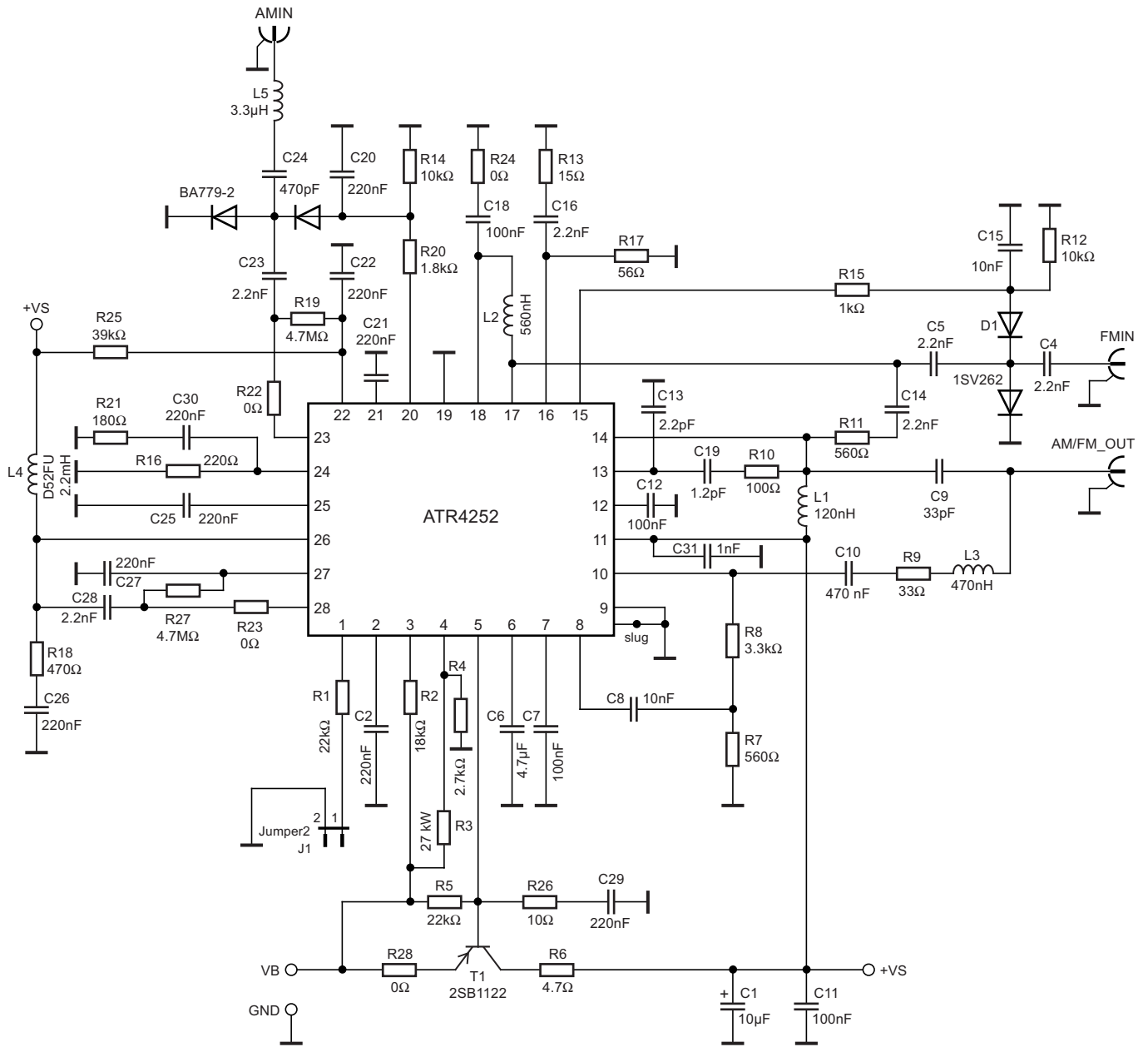

Figure 8-2. Common Base Configuration

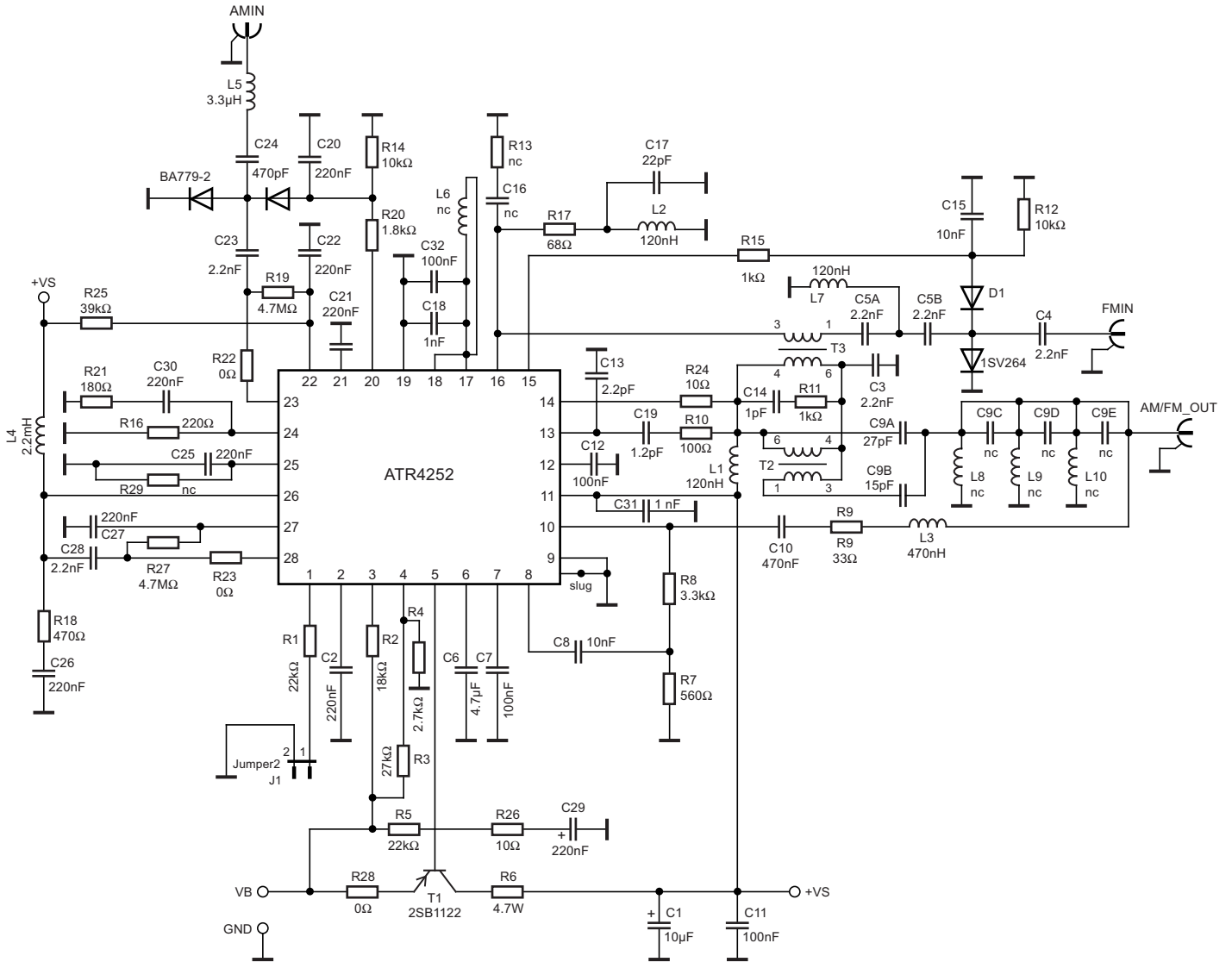

Figure 8-3. Antenna Dummy for Test Purposes

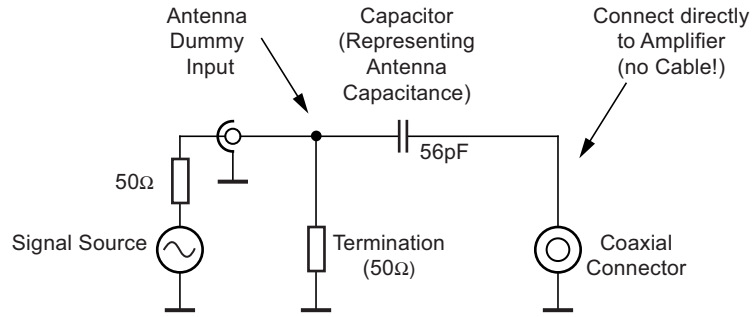
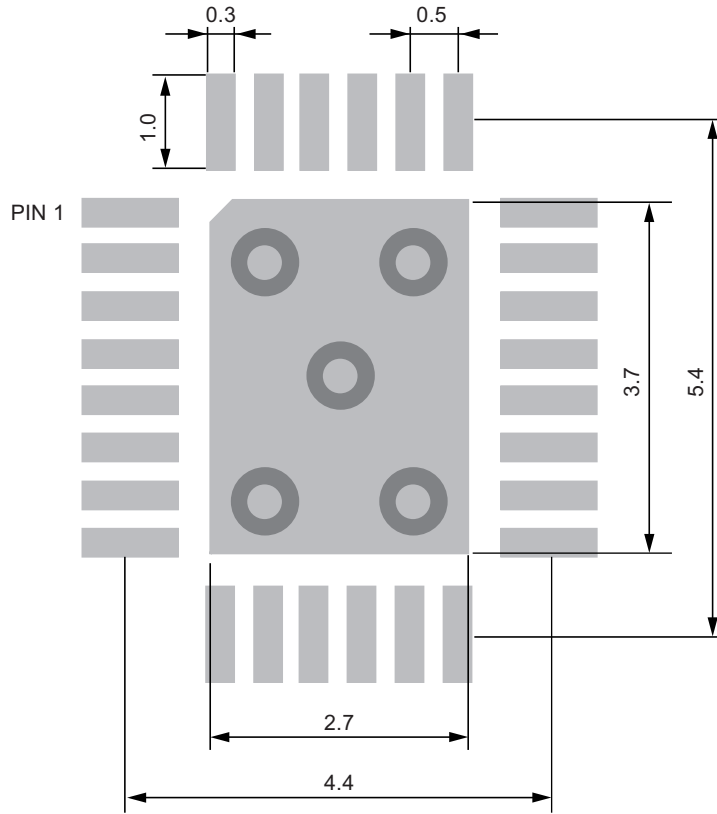

Figure 8-4. Recommended Footprint



9. Internal Cicutry

Table 9-1. Equivalent Pin Circuits (ESD Protection Circuits not Shown)

Pin	Symbol	Function
1	ANTENNA SENSE	
2, 13	VSFILTER; FMDET	
3	VSTART	
4	OVDET	
5	VREGO	
6, 12	AMTC1; FMTC	

Table 9-1. Equivalent Pin Circuits (ESD Protection Circuits not Shown) (Continued)



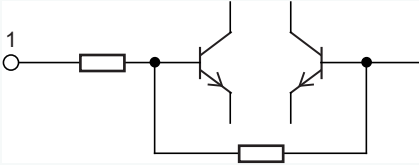
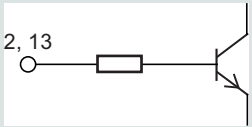
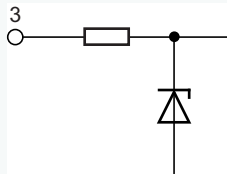
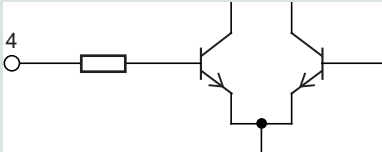
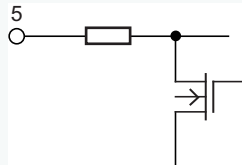
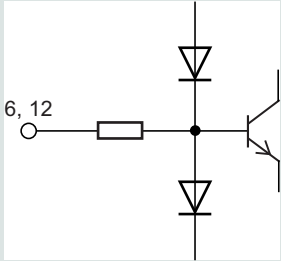

Pin	Symbol	Function
7	AMTC2	
8	AMDET	
9, 19	GND1, GND2	
10	AMOUT	
11	VS	
14, 26	FMC, AMLNAOUT	
15, 20	FMPD, AMPD	

Table 9-1. Equivalent Pin Circuits (ESD Protection Circuits not Shown) (Continued)

Pin	Symbol	Function
16, 18	FME, FMBIAS	
17	FMB	
21	REF	
22, 27	AMLNABIAS; AMBIAS	
23, 24, 28	AMLNAIN, AMLNASOURCE, AMBUFIN	
25	CASCODEFILTER	

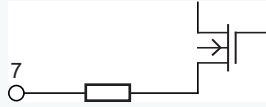
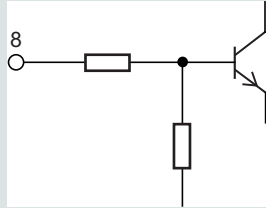
10. Ordering Information

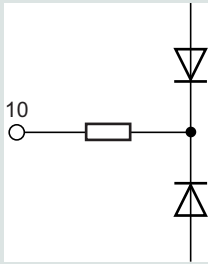
Extended Type Number	Package	Remarks	MOQ
ATR4252C-RAQW-1	VQFN 4x5 / 28L	Taped and reeled	6000 pieces

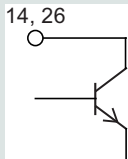
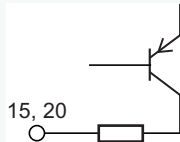
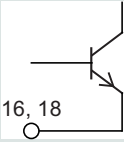
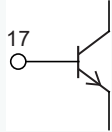
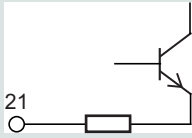
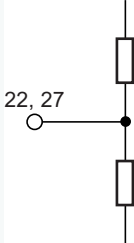
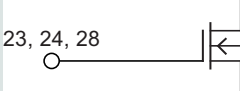
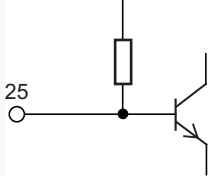
11. Package Information

technical drawings according to DIN specifications

Dimensions in mm

COMMON DIMENSIONS				
(Unit of Measure = mm)				
Symbol	MIN	NOM	MAX	NOTE
A	0.8	0.85	0.9	
A1	0	0.035	0.05	
A3	0.16	0.21	0.26	
D	3.9	4	4.1	
D2	2.5	2.6	2.7	
E	4.9	5	5.1	
E2	3.5	3.6	3.7	
L	0.35	0.4	0.45	
b	0.2	0.25	0.3	
e		0.5		

10/18/13

	TITLE	GPC	DRAWING NO.	REV.
Package Drawing Contact: packagedrawings@atmel.com	Package: VQFN_4x5_28L Exposed pad 2.6x3.6		6.543-5143.02-4	1

12. Revision History

Please note that the following page numbers referred to in this section refer to the specific revision mentioned, not to this document.

Revision No.	History
9264D-AUDR-11/14	• Section 10 "Ordering Information" on page 18 updated
9264C-AUDR-08/14	• Section 11 "Package Information" on page 18 updated
9264B-AUDR-01/14	• Section 11 "Package Information" on page 18 updated



Atmel Corporation 1600 Technology Drive, San Jose, CA 95110 USA T: (+1)(408) 441.0311 F: (+1)(408) 436.4200 | www.atmel.com

© 2014 Atmel Corporation. / Rev.: 9264D–AUDR–11/14

Atmel®, Atmel logo and combinations thereof, Enabling Unlimited Possibilities®, and others are registered trademarks or trademarks of Atmel Corporation in U.S. and other countries. Other terms and product names may be trademarks of others.

DISCLAIMER: The information in this document is provided in connection with Atmel products. No license, express or implied, by estoppel or otherwise, to any intellectual property right is granted by this document or in connection with the sale of Atmel products. EXCEPT AS SET FORTH IN THE ATMEL TERMS AND CONDITIONS OF SALES LOCATED ON THE ATMEL WEBSITE, ATMEL ASSUMES NO LIABILITY WHATSOEVER AND DISCLAIMS ANY EXPRESS, IMPLIED OR STATUTORY WARRANTY RELATING TO ITS PRODUCTS INCLUDING, BUT NOT LIMITED TO, THE IMPLIED WARRANTY OF MERCHANTABILITY, FITNESS FOR A PARTICULAR PURPOSE, OR NON-INFRINGEMENT. IN NO EVENT SHALL ATMEL BE LIABLE FOR ANY DIRECT, INDIRECT, CONSEQUENTIAL, PUNITIVE, SPECIAL OR INCIDENTAL DAMAGES (INCLUDING, WITHOUT LIMITATION, DAMAGES FOR LOSS AND PROFITS, BUSINESS INTERRUPTION, OR LOSS OF INFORMATION) ARISING OUT OF THE USE OR INABILITY TO USE THIS DOCUMENT, EVEN IF ATMEL HAS BEEN ADVISED OF THE POSSIBILITY OF SUCH DAMAGES. Atmel makes no representations or warranties with respect to the accuracy or completeness of the contents of this document and reserves the right to make changes to specifications and products descriptions at any time without notice. Atmel does not make any commitment to update the information contained herein. Unless specifically provided otherwise, Atmel products are not suitable for, and shall not be used in, automotive applications. Atmel products are not intended, authorized, or warranted for use as components in applications intended to support or sustain life.

SAFETY-CRITICAL, MILITARY, AND AUTOMOTIVE APPLICATIONS DISCLAIMER: Atmel products are not designed for and will not be used in connection with any applications where the failure of such products would reasonably be expected to result in significant personal injury or death ("Safety-Critical Applications") without an Atmel officer's specific written consent. Safety-Critical Applications include, without limitation, life support devices and systems, equipment or systems for the operation of nuclear facilities and weapons systems. Atmel products are not designed nor intended for use in military or aerospace applications or environments unless specifically designated by Atmel as military-grade. Atmel products are not designed nor intended for use in automotive applications unless specifically designated by Atmel as automotive-grade.