



Chipsmall Limited consists of a professional team with an average of over 10 year of expertise in the distribution of electronic components. Based in Hongkong, we have already established firm and mutual-benefit business relationships with customers from,Europe,America and south Asia,supplying obsolete and hard-to-find components to meet their specific needs.

With the principle of “Quality Parts,Customers Priority,Honest Operation,and Considerate Service”,our business mainly focus on the distribution of electronic components. Line cards we deal with include Microchip,ALPS,ROHM,Xilinx,Pulse,ON,Everlight and Freescale. Main products comprise IC,Modules,Potentiometer,IC Socket,Relay,Connector.Our parts cover such applications as commercial,industrial, and automotives areas.

We are looking forward to setting up business relationship with you and hope to provide you with the best service and solution. Let us make a better world for our industry!



## Contact us

Tel: +86-755-8981 8866 Fax: +86-755-8427 6832

Email & Skype: info@chipsmall.com Web: www.chipsmall.com

Address: A1208, Overseas Decoration Building, #122 Zhenhua RD., Futian, Shenzhen, China



## Single Element, Tooth Detecting Speed Sensor IC

### Features and Benefits

- Digital output representing target profile
- Single Hall element for twist-insensitive mounting and direction insensitive polarity
- True zero-speed operation
- Defined power-on state
- Air gap independent switchpoints
- Chopper stabilized
- Operation down to 3.3 V
- Factory programmable options:
  - Output polarity: low or high opposite tooth
  - Startup hysteresis: 40 G or 80 G
  - Threshold location: 30% or 50% from signal peak
  - Threshold update: single tooth (continuous) or four-tooth memory
- Fully synchronous digital logic with Scan Path and IDDQ testing

### Package: 4-pin SIP (suffix SG)



### Description

The ATS601LSG is a unique addition to the Allegro™ camshaft sensor IC family of products. As a single element, defined power-on state, sensor IC, it provides first falling edge detection, high running mode edge accuracy, and direction/orientation insensitivity over the full operating range of air gap, speed, and temperature. The ATS601LSG consists of an optimized Hall IC and a simple magnetic pellet configuration.

The single element Hall IC and magnetic pellet configuration switches in response to magnetic signals created by a ferromagnetic target. The IC contains a low bandwidth filter that increases the noise immunity and the signal-to-noise ratio of the sensor IC. Sophisticated digital circuit design eliminates the detrimental effects of target geometry discontinuity, magnet and system offsets, and thermal gradients. Signal processing is used to provide zero speed performance independent of air gap and also to dynamically adapt device performance to the typical operating conditions found in automotive applications, particularly camshaft sensing. The resulting output of the device is a digital representation of the ferromagnetic target profile.

A number of factory programmable options allow for performance optimization to meet specific application requirements.

The ATS601 is provided in a 4-pin SIP package (suffix SG) that is lead (Pb) free, with 100% matte tin leadframe plating.

### Functional Block Diagram

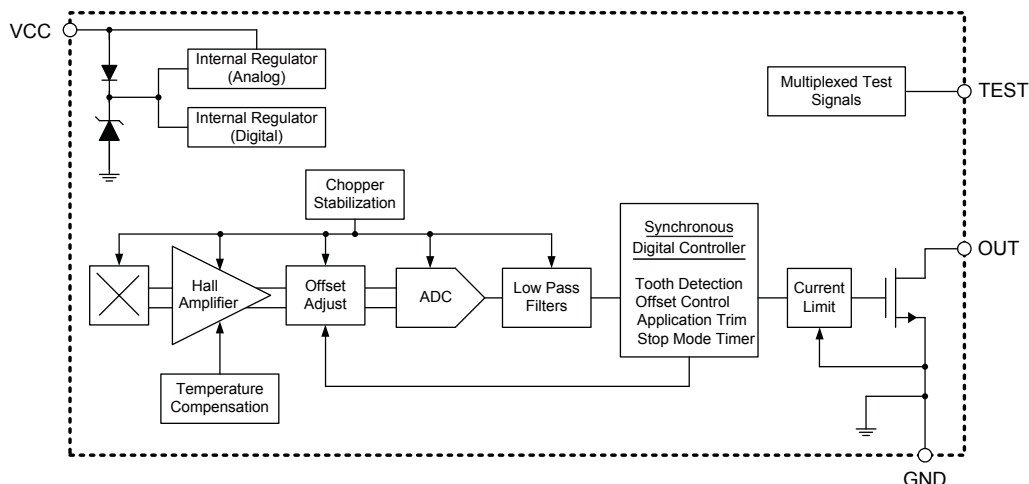

# ATS601

# Single Element, Tooth Detecting Speed Sensor IC

## Selection Guide

Part Number	Packing*
ATS601LSGTN-[A]-[AAM]-T	800 pieces per 13-in. reel



\*Contact Allegro™ for additional packing options.

### Configuration Options

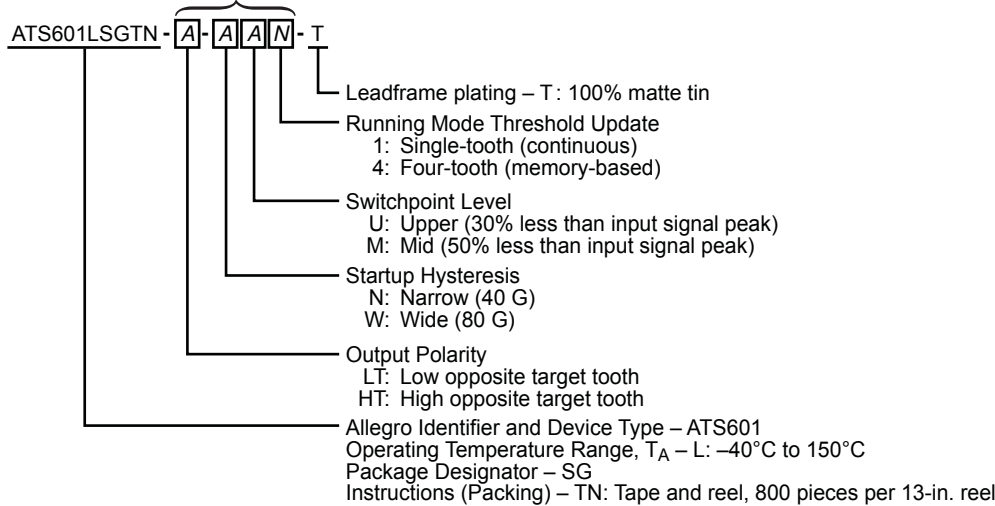

## Absolute Maximum Ratings

Characteristic	Symbol	Notes	Rating	Unit
Supply Voltage	$V_{CC}$		27	V
Reverse Supply Voltage	$V_{RCC}$		-18	V
Reverse Supply Current	$I_{RCC}$		-50	mA
Output Voltage	$V_{OUT}$		27	V
Reverse Output Voltage	$V_{ROUT}$	$R_{PU} > 1000 \Omega$	-0.5	V
Output Current	$I_{OUT}$	Internal current limiting is intended to protect the device from output short circuits, but is not intended for continuous operation.	25	mA
Reverse Output Current	$I_{ROUT}$	$V_{OUT} > -0.5 \text{ V}$ , $T_A = 25^{\circ}\text{C}$	-50	mA
Operating Ambient Temperature	$T_A$	L temperature range	-40 to 150	$^{\circ}\text{C}$
Maximum Junction Temperature	$T_{J(\text{max})}$		165	$^{\circ}\text{C}$
Storage Temperature	$T_{\text{stg}}$		-65 to 170	$^{\circ}\text{C}$

## Pin-out Diagram

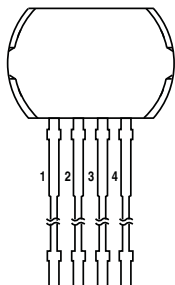

## Terminal List Table

Name	Number	Function
VCC	1	Supply voltage
OUT	2	Open drain output
TEST	3	Test pin (MUX)
GND	4	Ground





**OPERATING CHARACTERISTICS** Valid using Allegro reference target 8X, and  $V_{CC}$  and  $T_A$  within specification; unless otherwise specified

Characteristic	Symbol	Test Conditions	Min.	Typ. <sup>1</sup>	Max.	Unit <sup>2</sup>	
<b>Electrical Characteristics</b>							
Supply Voltage <sup>3</sup>	$V_{CC}$	Continuous operation, $T_J < T_J(\text{max})$	3.3	–	24	V	
Undervoltage Lockout <sup>4</sup>	$V_{CC(\text{UV})\text{rise}}$	Rising $V_{CC}$ (0 V → 5 V)	2.5	–	3.1	V	
	$V_{CC(\text{UV})\text{fall}}$	Falling $V_{CC}$ (5 V → 0 V)	2.4	–	3.0	V	
Supply Zener Clamp Voltage	$V_{Z\text{supply}}$	$I_{CC} = I_{CC(\text{max})} + 3 \text{ mA}$ ; $T_A = 25^\circ\text{C}$	27	–	–	V	
Reverse Supply Zener Clamp Voltage	$V_{RZ\text{supply}}$	$I_{CC} = -3 \text{ mA}$ , $T_A = 25^\circ\text{C}$	-18	–	–	V	
Supply Current	$I_{CC}$		4	–	10	mA	
<b>Power-On Characteristics</b>							
Power-On Time <sup>5</sup>	$t_{PO}$	$V_{CC} > V_{CC(\text{min})}$	–	–	1	ms	
Power-On State <sup>6</sup>	POS	Connected as in figure 1	–	High	–	V	
<b>Output Stage Characteristics</b>							
Output On Voltage	$V_{\text{OUT}(\text{SAT})}$	$I_{\text{OUT}} = 15 \text{ mA}$ , Output = On state ( $V_{\text{OUT}} = \text{Low}$ )	–	–	450	mV	
Output Zener Clamp Voltage	$V_{Z\text{output}}$	$I_{\text{OUT}} = 3 \text{ mA}$ , $T_A = 25^\circ\text{C}$	27	–	–	V	
Output Current Limit	$I_{\text{OUT}(\text{LIM})}$	Output = On state ( $V_{\text{OUT}} = \text{Low}$ )	25	–	80	mA	
Output Leakage Current	$I_{\text{OUT}(\text{OFF})}$	$V_{\text{OUT}} = 24 \text{ V}$ , Output = Off state ( $V_{\text{OUT}} = \text{High}$ )	–	–	10	$\mu\text{A}$	
Output Rise Time	$t_r$	Measured 10% to 90% of $V_{\text{OUT}}$ ; $R_{\text{PU}} = 1 \text{ k}\Omega$ , $C_L = 4.7 \text{ nF}$ , $V_{\text{PU}} = 5 \text{ V}$ ; see figure 2	–	10	–	$\mu\text{s}$	
Output Fall Time	$t_f$	Measured 90% to 10% of $V_{\text{OUT}}$ ; $R_{\text{PU}} = 1 \text{ k}\Omega$ , $C_L = 4.7 \text{ nF}$ , $V_{\text{PU}} = 5 \text{ V}$ ; see figure 2	3	6	10	$\mu\text{s}$	
Output Delay Time <sup>7</sup>	$t_d$	1 kHz sinusoidal input signal; see figure 3	–	50	–	$\mu\text{s}$	
<b>Performance Characteristics</b>							
Operational Air Gap Range <sup>8</sup>	AG	N option	Allegro 8X reference target	1.0	–	3.0	mm
		W option		0.5	–	2.5	mm
Magnetic Signal Range	$B_{\text{SIG}}$	N option	Peak to peak signal	60	–	1000	$G_{\text{PKPK}}$
		W option		120	–	1000	$G_{\text{PKPK}}$
Analog Signal Bandwidth	BW	Equivalent to -3 dB cutoff frequency	–	8	–	kHz	

Continued on the next page...

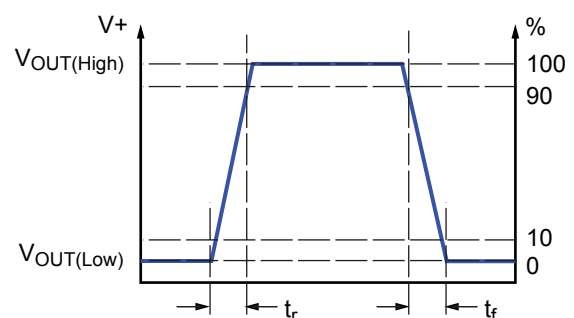
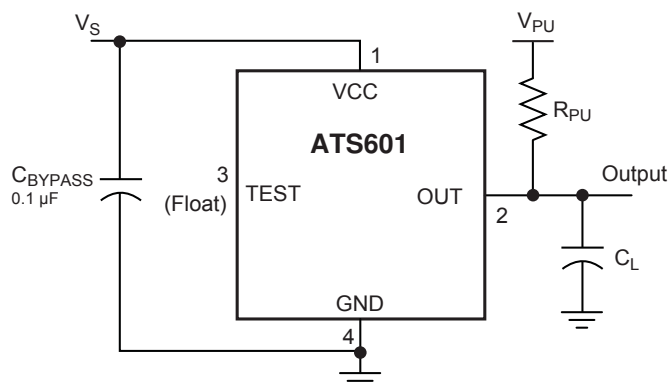

Figure 1. Typical application circuit

Figure 2. Output Rise Time and Output Fall Time

**OPERATING CHARACTERISTICS** (continued) Valid using Allegro reference target 8X, and  $V_{CC}$  and  $T_A$  within specification; unless otherwise specified

Characteristic	Symbol	Test Conditions	Min.	Typ. <sup>1</sup>	Max.	Unit <sup>2</sup>	
<b>Operating Mode Characteristics</b>							
Output Polarity	$V_{OUT}$	LT option	Opposite target tooth, connected as in figure 1	–	Low	–	V
		HT option		–	High	–	V
Startup Hysteresis	$B_{HYS(su)}$	N option	Amount of signal movement needed to generate first output edge	–	40	–	G
		W option		–	80	–	G
Threshold Update Memory	–	1 option	Number of target teeth (peaks) stored in memory for threshold update algorithm	–	1	–	tooth
		4 option		–	4	–	tooth
Running Mode Switchpoint	$B_{ST}$	U option	% of peak-to-peak, referenced to tooth signal, see figure 4	25	30	35	%
		M option		45	50	55	%
Running Mode Internal Hysteresis	$B_{HYS(m)}$	% of peak-to-peak signal	5	10	15	%	
Stop Mode Timer Period	$t_{SM}$	Timer interval to initiate Stop mode, no sensed magnetic edges	–	5	–	s	
Chopper Frequency	$f_C$		–	167	–	kHz	

<sup>1</sup>Typical values are at  $T_A = 25^\circ\text{C}$  and  $V_{CC} = 12\text{ V}$ . Performance may vary for individual units, within the specified maximum and minimum limits.

<sup>2</sup>1 G (gauss) = 0.1 mT (millitesla).

<sup>3</sup>Maximum voltage must be adjusted for power dissipation and junction temperature; see Power Derating section.

<sup>4</sup>Between  $V_{CC(\text{min})}$  and  $V_{CC(\text{UV})}$  output switching continues to occur but device performance is not guaranteed.

<sup>5</sup>Power-On Time consists of the time from when  $V_{CC}$  rises above  $V_{CC(\text{min})}$  until the earliest output edge is possible.

<sup>6</sup>Independent of output polarity option (HT or LT).

<sup>7</sup>Output Delay Time is the duration from when a crossing of the magnetic signal switchpoint,  $B_{ST}$ , occurs to when the electrical output signal,  $V_{OUT}$ , reaches 90% of  $V_{OUT(\text{high})}$ .

<sup>8</sup>Reduced minimum air gap with N option due to potential for extra switching on first tooth due to magnetic overshoot larger than startup hysteresis, characteristic of the Allegro 8X reference target. Device functions properly in Running mode down to 0.5 mm air gap.

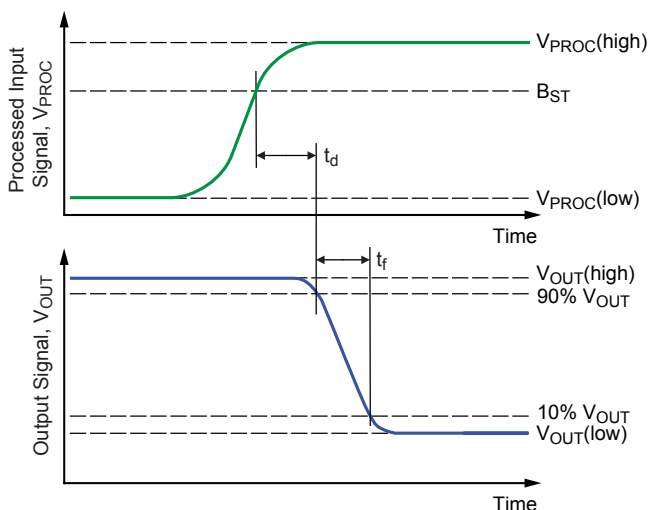

Figure 3. Output Delay Time and Output Fall Time

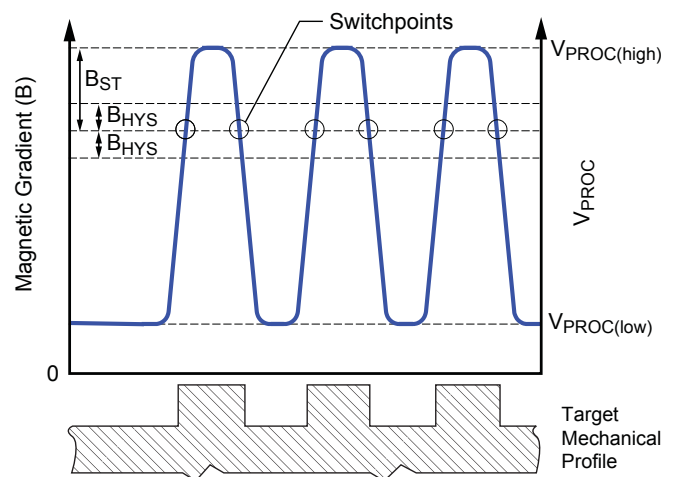

Figure 4. Running Mode Switchpoint and Internal Hysteresis

## Power Derating

**Thermal Characteristics** may require derating at maximum conditions, see Power Derating section

Characteristic	Symbol	Test Conditions*	Value	Unit
Package Thermal Resistance	$R_{\theta JA}$	Single layer PCB, with copper limited to solder pads	126	$^{\circ}\text{C}/\text{W}$
		Single layer PCB, with copper limited to solder pads and 3.57 in. <sup>2</sup> (23.03 cm <sup>2</sup> ) copper area each side	84	$^{\circ}\text{C}/\text{W}$

\*Additional thermal information available on the Allegro website

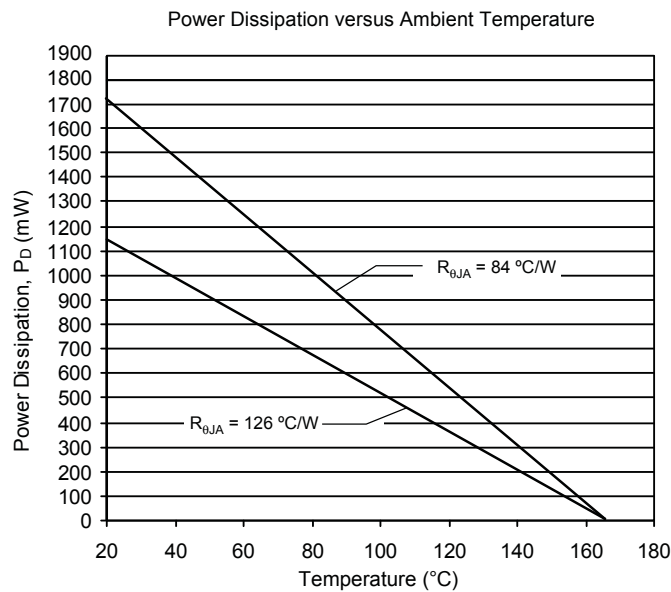
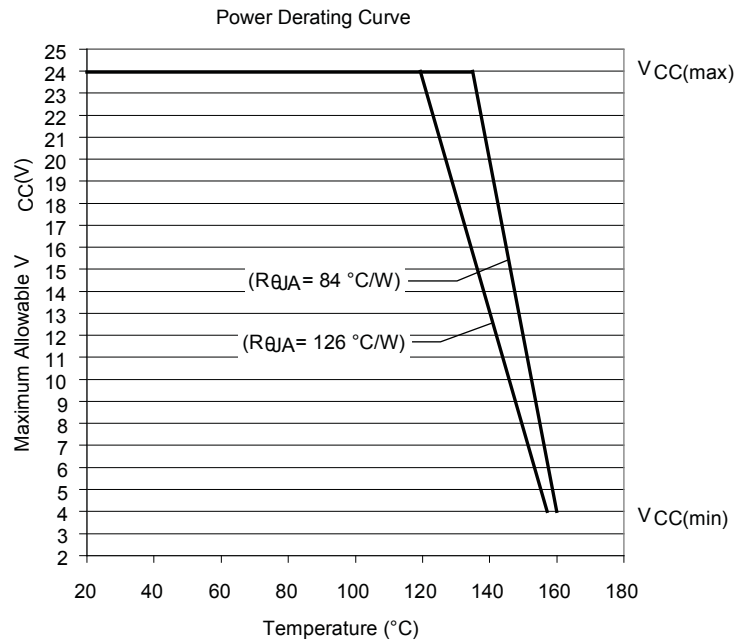

Characteristic Performance

Supply Current versus Ambient Temperature

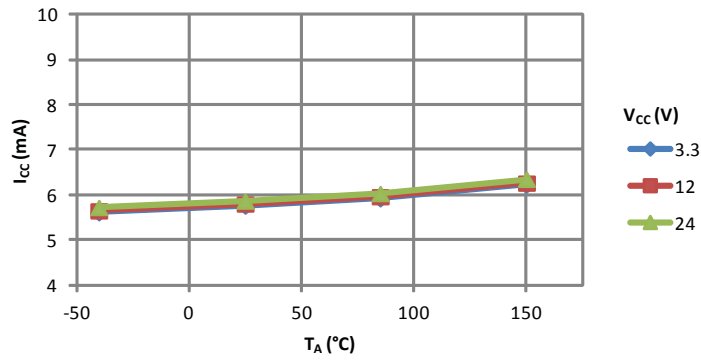

Output On Voltage versus Ambient Temperature

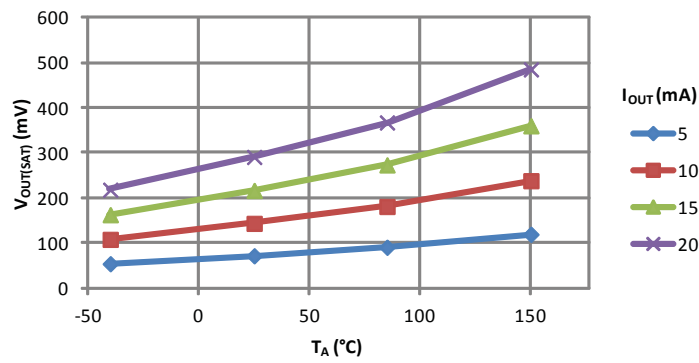

Output Fall Time versus Ambient Temperature

V<sub>PU</sub> = 5V, R<sub>PU</sub> = 1kΩ, C<sub>L</sub> = 4.7 nF

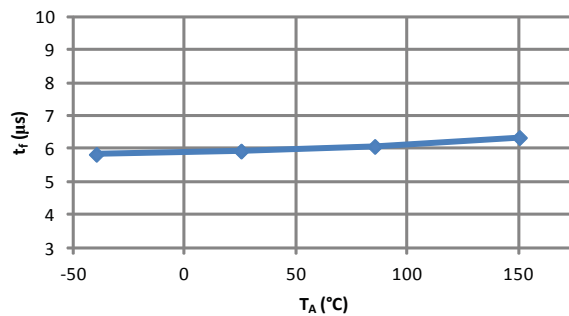

### Relative Timing Accuracy versus Air Gap

Rising Mechanical Edge, "U" Switchpoint Option  
1000 rpm, Relative to 0.5 mm Air Gap

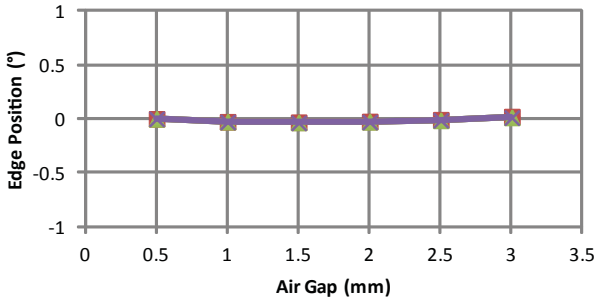

### Relative Timing Accuracy versus Air Gap

Rising Mechanical Edge, "M" Switchpoint Option  
1000 rpm, Relative to 0.5 mm Air Gap

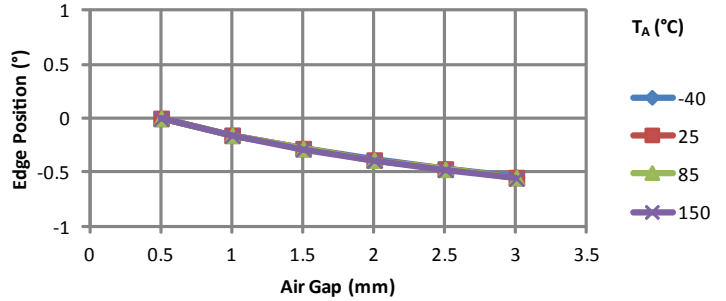

### Relative Timing Accuracy versus Air Gap

Falling Mechanical Edge, "U" Switchpoint Option  
1000 rpm, Relative to 0.5 mm Air Gap

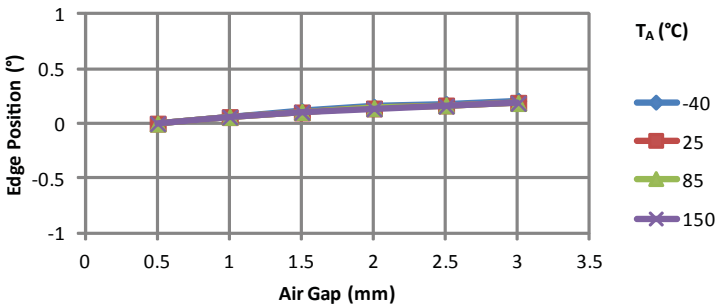

### Relative Timing Accuracy versus Air Gap

Falling Mechanical Edge, "M" Switchpoint Option  
1000 rpm, Relative to 0.5 mm Air Gap

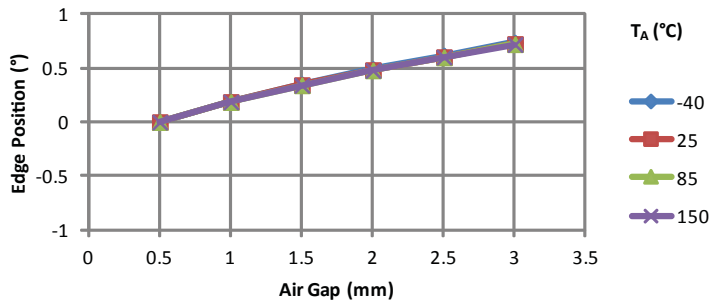

### Relative Timing Accuracy versus Speed

Rising Electrical Edge  
25°C, Relative to 100 rpm Gear Speed

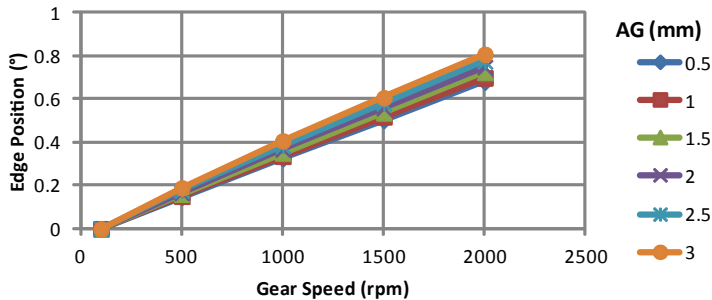

### Relative Timing Accuracy versus Speed

Falling Electrical Edge  
25°C, Relative to 100 rpm Gear Speed

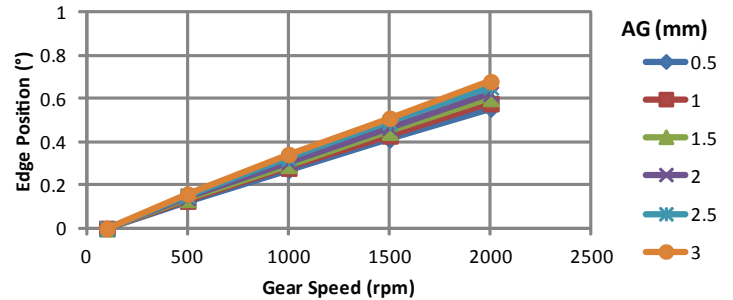



Reference Target Characteristics

REFERENCE TARGET 8X

Characteristic	Symbol	Test Conditions	Typ.	Units	Symbol Key
Outside Diameter	$D_o$	Outside diameter of target	120	mm	
Face Width	F	Breadth of tooth, with respect to branded face	6	mm	
Circular Tooth Length	t	Length of tooth, with respect to branded face; measured at $D_o$	23.6	mm	
Circular Valley Length	$t_v$	Length of valley, with respect to branded face; measured at $D_o$	23.6	mm	
Tooth Whole Depth	$h_t$		5	mm	
Material		CRS 1018	-	-	

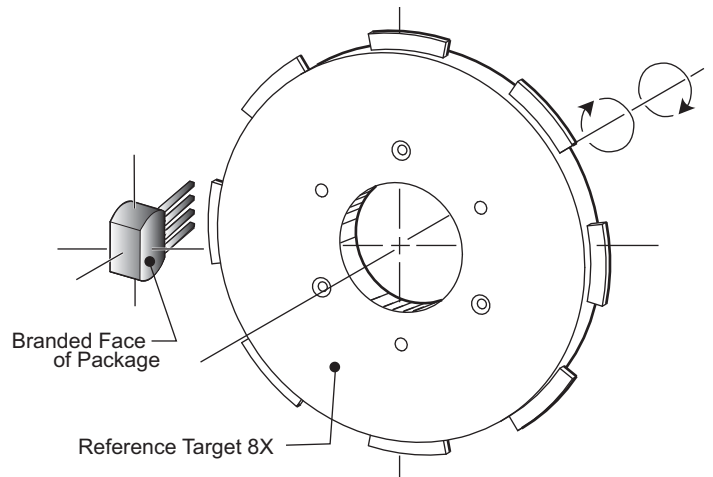

## Functional Description

### Sensing Technology

The ATS601LSG contains a single-chip Hall effect sensor IC, a 4-pin leadframe and a specially designed permanent magnet. The Hall IC supports a chopper stabilized Hall element that measures the magnetic gradient created by the passing of a ferromagnetic object. The difference in the magnetic field strength created by teeth and valleys allows the device to generate a digital output signal that is representative of the target features, independent of the direction of target rotation or rotational orientation of the sensor IC.

The ATS601LSG gear tooth sensor device contains a self-calibrating Hall effect IC that provides a Hall element, a temperature compensated amplifier, and offset cancellation circuitry. The IC also contains a voltage regulator that provides supply noise rejection over the operating voltage range. The Hall transducers and the electronics are integrated on the same silicon substrate by a proprietary BiCMOS process. Changes in temperature do not greatly affect this device due to the stable amplifier design and the offset rejection circuitry.

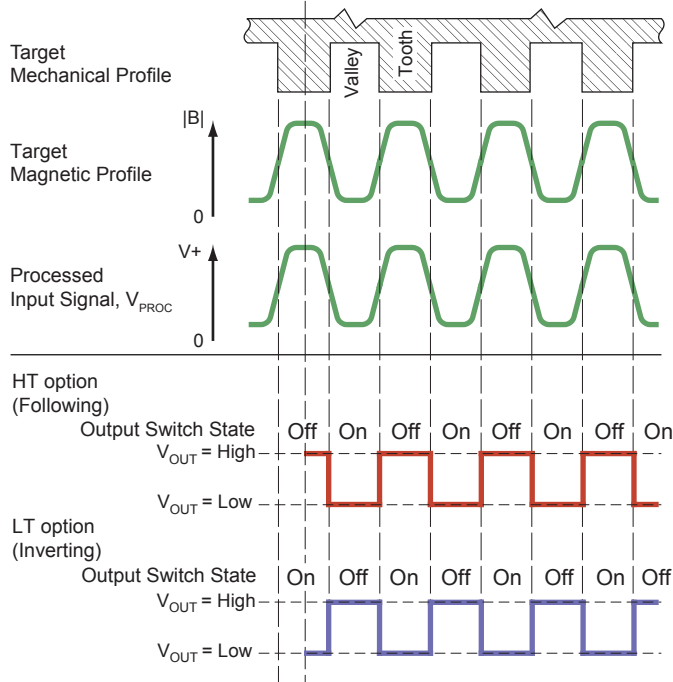

Figure 5. Output Polarity (when connected as shown in figure 1)

### Output Polarity

The polarity of the output is programmable to either be low opposite target teeth (LT option) or high opposite target teeth (HT option). See figure 5.

### Start-Up Detection

The ATS601LSG always powers-on in the high output state, independent of the polarity option (HT or LT) selected. The output will transition to the low state at the first mechanical edge corresponding to a high-to-low output transition. See figure 6.

### Threshold Update

The ATS601 has two programmable options for the threshold update used to establish running mode switching levels. With single-tooth update (1 option) the switching threshold for a tooth

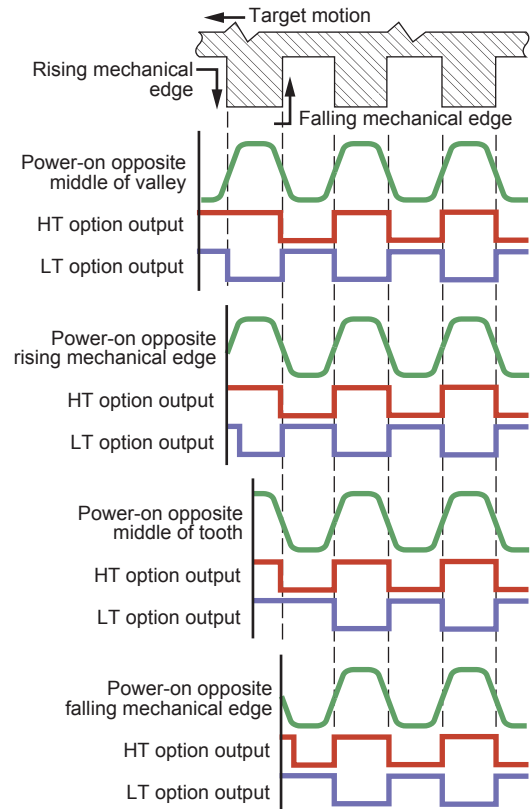

Figure 6. Start-up behavior (when connected as shown in figure 1)

is established based on the measured peak value of the previous tooth. This option can be used with any number of teeth-targets, and is comparable to the Continuous Update mode used on many Allegro sensor ICs.

With the four-tooth update (4 option), peak information from the last four teeth is stored in on-chip memory. Switching thresholds for the upcoming tooth are established based on the stored information from four teeth earlier. When used with four-tooth targets, this allows for optimized switchpoints based on the same tooth from the previous revolution of the target. The programmable threshold update results in improved output switching accuracy on targets with runout and tooth-to-tooth variation (including narrow valleys). With the four-tooth update option, during the first target rotation the device behaves the same as in single-tooth update while one rotation of target information is stored to memory. Similarly, if a direction change or other sudden magnetic signal change is detected, the device returns to single-tooth update mode and re-learns four target teeth before returning to four-tooth update mode.

### Switchpoints

The running mode switchpoints in the ATS601LSG are established dynamically as a percentage of the amplitude of the signal,  $V_{PROC}$ . There are two switchpoint ( $B_{ST}$ ) choices, selectable with the U or M options. The ATS601LSG uses a single switch-

ing threshold (operate and release point identical) with internal hysteresis.

The internal running mode hysteresis ( $B_{HYS(rm)}$ ) allows for high performance switching accuracy on both rising and falling edges while maintaining immunity to false switching on noise, vibration, backlash, or other transient events. Figure 7 demonstrates the function of this hysteresis when switching on an anomalous peak.

### Power Supply Protection

The ATS601LSG contains an on-chip regulator and can operate over a wide range of supply voltage levels. For applications using an unregulated power supply, transient protection may be added externally. For applications using a regulated supply line, EMI and RFI protection may still be required. Contact Allegro for information on EMC specification compliance.

When the supply voltage falls below the undervoltage lockout level,  $V_{CC(UV)fall}$ , the device switches to the Off ( $V_{OUT} = high$ ) state. The device remains in that state until the voltage level is restored to the  $V_{CC}$  operating range. Changes in the target magnetic profile have no effect until voltage is restored. This prevents false signals caused by undervoltage conditions from propagating to the output of the sensor IC.

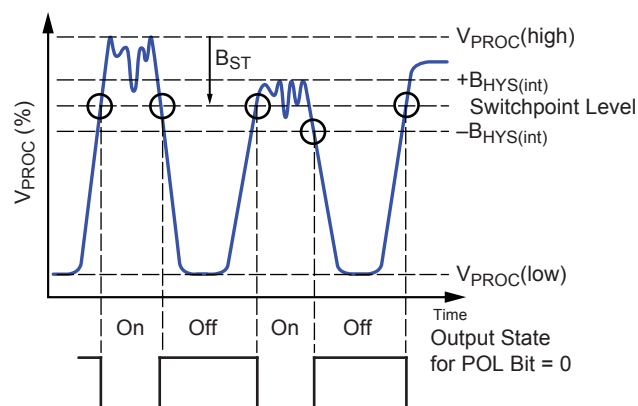

Figure 7. Switching on internal hysteresis

## **Operating Modes**

### *Startup Hysteresis Mode*

After power-on, a minimum amount of peak-to-peak magnetic movement is required before the ATS601 will begin generating output edges. This required signal movement threshold is referred to as the startup hysteresis. There are two programmable options for this startup hysteresis threshold. With narrow (N option) startup hysteresis, the device will switch to a farther air gap, but will have reduced immunity to magnetic overshoot, thus limiting its close air gap capability. With wide (W option) startup hysteresis, the device will have a reduced maximum air gap capability, but improved magnetic overshoot immunity. After the magnetic signal exceeds the startup hysteresis value for the first time, the device will transition to Calibration mode.

### *Calibration Mode*

In Calibration mode, the ATS601 uses threshold based switching with continuous update. This ensures that all teeth and valleys are captured correctly, but provides slightly reduced accuracy relative to Running mode. The device stays in Calibration mode long enough to correctly capture enough peaks to fill the Running mode threshold memory. This corresponds to three output edges with the single-tooth update (1 option) and nine edges with the four-tooth update (4 option). After Calibration mode is complete, the device transitions to Running mode.

### *Running Mode*

In Running mode the ATS601 uses threshold based switching with internal hysteresis described previously, in the Threshold Update and Switchpoints sections. The threshold update is intended to optimize output switching accuracy when used with common camshaft targets, including cases with runout and narrow target valleys.

### *Stop Mode*

The ATS601 has an internal timer that begins counting on each output edge. If the timer reaches  $t_{SM}$  before another output edge occurs, the device moves into Stop mode. Stop mode is the same as Startup Hysteresis mode, but with a hysteresis value determined as a percentage of the previously measured target amplitude. Stop mode ensures no missed or extra output edges, even during situations with large temperature drifts and no target rotation.

### *Watchdog*

The ATS601 has a peak detector continuously tracking the magnetic signal. If a sudden large signal change causes the sensor IC output to stop switching but the peak detector continues to detect valid signal movement, the watchdog will be fired. In case of a watchdog event, the sensor IC performs a self-reset and returns to the initial Startup Hysteresis mode to regain output switching.

Power Derating

Power Derating

The device must be operated below the maximum junction temperature of the device,  $T_J(\text{max})$ . Under certain combinations of peak conditions, reliable operation may require derating supplied power or improving the heat dissipation properties of the application. This section presents a procedure for correlating factors affecting operating  $T_J$ . (Thermal data is also available on the Allegro MicroSystems website.)

The Package Thermal Resistance,  $R_{\theta JA}$ , is a figure of merit summarizing the ability of the application and the device to dissipate heat from the junction (die), through all paths to the ambient air. Its primary component is the Effective Thermal Conductivity,  $K$ , of the printed circuit board, including adjacent devices and traces. Radiation from the die through the device case,  $R_{\theta JC}$ , is a relatively small component of  $R_{\theta JA}$ . Ambient air temperature,  $T_A$ , and air motion are significant external factors, damped by overmolding.

The effect of varying power levels (Power Dissipation,  $P_D$ ), can be estimated. The following formulas represent the fundamental relationships used to estimate  $T_J$ , at  $P_D$ .

$$P_D = V_{IN} \times I_{IN} \tag{1}$$

$$\Delta T = P_D \times R_{\theta JA} \tag{2}$$

$$T_J = T_A + \Delta T \tag{3}$$

For example, given common conditions such as:  $T_A = 25^\circ\text{C}$ ,  $V_{CC} = 12\text{ V}$ ,  $I_{CC} = 7\text{ mA}$ , and  $R_{\theta JA} = 126\text{ }^\circ\text{C/W}$ , then:

$$P_D = V_{CC} \times I_{CC} = 12\text{ V} \times 7\text{ mA} = 84\text{ mW}$$

$$\Delta T = P_D \times R_{\theta JA} = 84\text{ mW} \times 126\text{ }^\circ\text{C/W} = 10.6^\circ\text{C}$$

$$T_J = T_A + \Delta T = 25^\circ\text{C} + 10.6^\circ\text{C} = 35.6^\circ\text{C}$$

A worst-case estimate,  $P_D(\text{max})$ , represents the maximum allowable power level ( $V_{CC}(\text{max})$ ,  $I_{CC}(\text{max})$ ), without exceeding  $T_J(\text{max})$ , at a selected  $R_{\theta JA}$  and  $T_A$ .

*Example:* Reliability for  $V_{CC}$  at  $T_A = 150^\circ\text{C}$ , package SG, using single layer PCB.

Observe the worst-case ratings for the device, specifically:  $R_{\theta JA} = 126^\circ\text{C/W}$ ,  $T_J(\text{max}) = 165^\circ\text{C}$ ,  $V_{CC(\text{absmax})} = 24\text{ V}$ , and  $I_{CC} = 10\text{ mA}$ .

Calculate the maximum allowable power level,  $P_D(\text{max})$ . First, invert equation 3:

$$\Delta T(\text{max}) = T_J(\text{max}) - T_A = 165^\circ\text{C} - 150^\circ\text{C} = 15^\circ\text{C}$$

This provides the allowable increase to  $T_J$  resulting from internal power dissipation. Then, invert equation 2:

$$P_D(\text{max}) = \Delta T(\text{max}) \div R_{\theta JA} = 15^\circ\text{C} \div 126\text{ }^\circ\text{C/W} = 119\text{ mW}$$

Finally, invert equation 1 with respect to voltage:

$$V_{CC(\text{est})} = P_D(\text{max}) \div I_{CC} = 119\text{ mW} \div 10\text{ mA} = 11.9\text{ V}$$

The result indicates that, at  $T_A$ , the application and device can dissipate adequate amounts of heat at voltages  $\leq V_{CC(\text{est})}$ .

Compare  $V_{CC(\text{est})}$  to  $V_{CC(\text{max})}$ . If  $V_{CC(\text{est})} \leq V_{CC(\text{max})}$ , then reliable operation between  $V_{CC(\text{est})}$  and  $V_{CC(\text{max})}$  requires enhanced  $R_{\theta JA}$ . If  $V_{CC(\text{est})} \geq V_{CC(\text{max})}$ , then operation between  $V_{CC(\text{est})}$  and  $V_{CC(\text{max})}$  is reliable under these conditions.



## Package SG, 4-Pin SIP

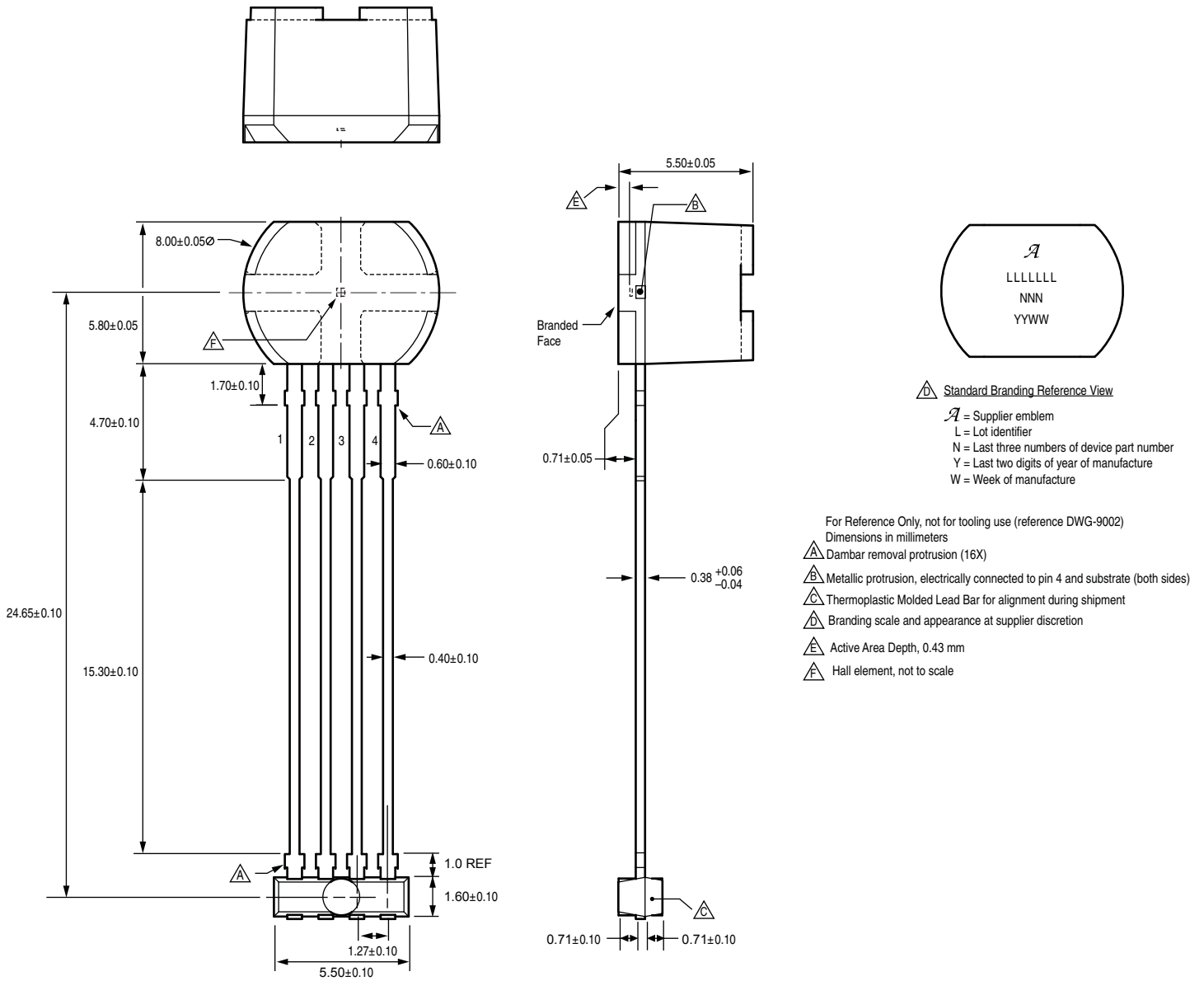

Copyright ©2013, Allegro MicroSystems, LLC

Allegro MicroSystems, LLC reserves the right to make, from time to time, such departures from the detail specifications as may be required to permit improvements in the performance, reliability, or manufacturability of its products. Before placing an order, the user is cautioned to verify that the information being relied upon is current.

Allegro's products are not to be used in any devices or systems, including but not limited to life support devices or systems, in which a failure of Allegro's product can reasonably be expected to cause bodily harm.

The information included herein is believed to be accurate and reliable. However, Allegro MicroSystems, LLC assumes no responsibility for its use; nor for any infringement of patents or other rights of third parties which may result from its use.

For the latest version of this document, visit our website:

[www.allegromicro.com](http://www.allegromicro.com)

