



Chipsmall Limited consists of a professional team with an average of over 10 year of expertise in the distribution of electronic components. Based in Hongkong, we have already established firm and mutual-benefit business relationships with customers from,Europe,America and south Asia,supplying obsolete and hard-to-find components to meet their specific needs.

With the principle of "Quality Parts,Customers Priority,Honest Operation,and Considerate Service",our business mainly focus on the distribution of electronic components. Line cards we deal with include Microchip,ALPS,ROHM,Xilinx,Pulse,ON,Everlight and Freescale. Main products comprise IC,Modules,Potentiometer,IC Socket,Relay,Connector.Our parts cover such applications as commercial,industrial, and automotives areas.

We are looking forward to setting up business relationship with you and hope to provide you with the best service and solution. Let us make a better world for our industry!



Contact us

Tel: +86-755-8981 8866 Fax: +86-755-8427 6832

Email & Skype: info@chipsmall.com Web: www.chipsmall.com

Address: A1208, Overseas Decoration Building, #122 Zhenhua RD., Futian, Shenzhen, China



***Two-Wire True Zero Speed Miniature Differential
Peak-Detecting Gear Tooth Sensor IC***

Not for New Design

These parts are in production but have been determined to be **NOT FOR NEW DESIGN**. This classification indicates that sale of this device is currently restricted to existing customer applications. The device should not be purchased for new design applications because obsolescence in the near future is probable. Samples are no longer available.

Date of status change: January 2, 2009

Recommended Substitutions:

NOTE: For detailed information on purchasing options, contact your local Allegro field applications engineer or sales representative.

Allegro MicroSystems, Inc. reserves the right to make, from time to time, revisions to the anticipated product life cycle plan for a product to accommodate changes in production capabilities, alternative product availabilities, or market demand. The information included herein is believed to be accurate and reliable. However, Allegro MicroSystems, Inc. assumes no responsibility for its use; nor for any infringements of patents or other rights of third parties which may result from its use.

Two-Wire True Zero Speed Miniature Differential Peak-Detecting Gear Tooth Sensor IC

Features and Benefits

- Fully optimized differential digital gear tooth sensor IC
- Single chip IC for high reliability
- Internal current regulator for 2-wire operation
- Small mechanical size (8 mm diameter x 5.5 mm depth)
- Air gap independent switchpoints
- Digital output representing gear profile
- Precise duty cycle signal over operating temperature range
- Large operating air gaps
- Automatic Gain Control (AGC)
- Automatic Offset Adjustment (AOA)

Continued on the next page...

Packages: 4 pin SIP (suffix SH)



Not to scale

Description

The components in speed sensing applications continue to diminish in size to meet spatial constraints and weight reduction requirements. As the geometries of gears become smaller, this can compromise the capabilities of a gear speed sensor. The ATS645 Hall-element-to-Hall-element spacing of only 1.5 mm makes this device uniquely capable of accommodating very fine-pitch gears. In addition, the ATS645 signal peak-detecting algorithm supports consistent switching at relatively large air gaps, where the peak-to-peak amplitude is small. These features make the ATS645 the ideal solution to detect the speed of fine-pitch targets such as those found in ABS (antilock braking) systems.

The ATS645 combines a Hall-effect sensing integrated circuit and rare earth pellet to provide a manufacturer-friendly solution for true zero-speed digital gear-tooth sensing in two-wire applications. The device consists of a single-shot molded plastic package that includes a samarium cobalt pellet, a pole piece, and a Hall-effect integrated circuit that has been optimized to the magnetic circuit. This small package can be easily assembled and used in conjunction with a wide variety of gear shapes and sizes.

Continued on the next page...

Functional Block Diagram

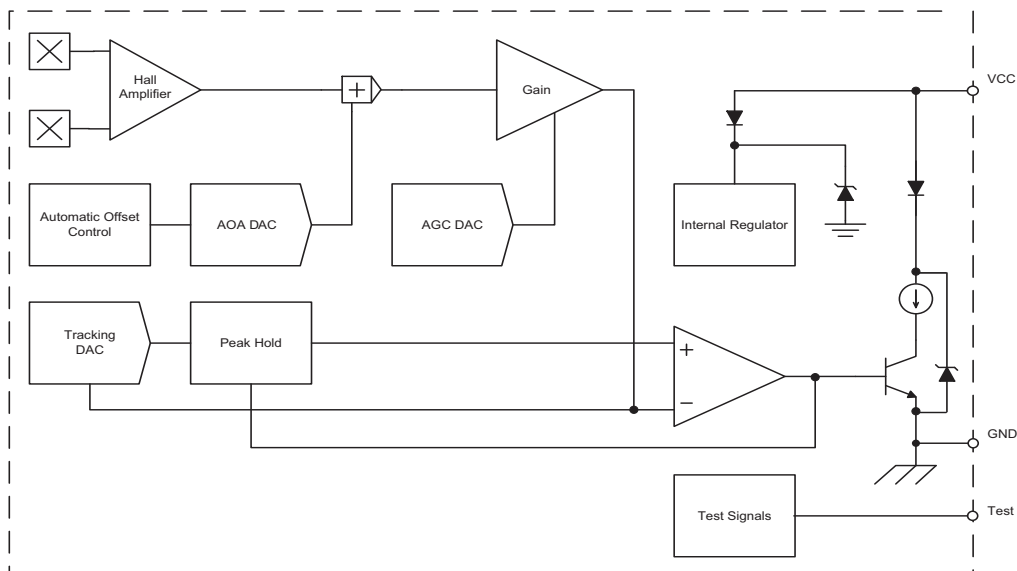

Features and Benefits (continued)

- True zero-speed operation
- Undervoltage lockout
- Wide operating voltage range
- Defined power-on state

Description (continued)

The integrated circuit incorporates a dual-element Hall effect circuit as well as signal processing that switches the output state in response to changes in the magnetic gradients created by ferromagnetic gear teeth. The circuitry contains a sophisticated digital circuit to eliminate magnet and system offsets and to achieve true zero speed operation (U.S. Patent 5,917,320). A-D and D-A converters are used to adjust the device gain at power-on and to allow switching independent of the breadth of the air gap.

The regulated current output is configured for two wire applications, requiring one less wire for operation than do switches with the more traditional open-collector output. The package is available in a lead (Pb) free version, with 100% matte tin leadframe plating.

Part Number	Packing*	I _{CC} Typical
ATS645LSHTN-I1-T	Tape and Reel 13-in. 800 pcs./reel	6.0 Low to 14.0 High mA
ATS645LSHTN-I2-T	Tape and Reel 13-in. 800 pcs./reel	7.0 Low to 14.0 High mA

*Contact Allegro for additional packing options. Some restrictions may apply to certain types of sales. Contact Allegro for details.



Absolute Maximum Ratings

Characteristic	Symbol	Notes	Rating	Units
Supply Voltage	V _{CC}		28	–
Reverse-Supply Voltage	V _{RCC}		–18	V
Operating Ambient Temperature	T _A	Range L	–40 to 150	°C
Maximum Junction Temperature	T _{J(max)}		165	°C
Storage Temperature	T _{stg}		–65 to 170	°C

Pin-out Diagram

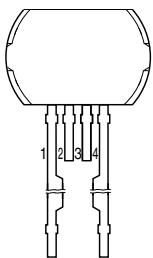

Terminal List

Name	Description	Number
VCC	Connects power supply to chip	1
NC	No connection	2
TEST	For Allegro use, float or tie to GND	3
GND	Ground terminal	4

OPERATING CHARACTERISTICS using reference target 60-0, T _A and V _{CC} within specification, unless otherwise noted						
CHARACTERISTIC	Symbol	Test Conditions	Min.	Typ. ¹	Max.	Units
ELECTRICAL CHARACTERISTICS						
Supply Voltage ²	V _{CC}	Operating; T _J < 165 °C	4.0	–	24	V
Undervoltage Lockout	V _{CC(UV)}	V _{CC} 0 → 5 V and 5 → 0 V	–	–	4.0	V
Supply Zener Clamp Voltage	V _Z	I _{CC} = I _{CC(max)} + 3 mA; T _A = 25°C	28	–	–	V
Supply Zener Current	I _Z	Test conditions only; V _Z = 28 V	–	–	I _{CC(max)} ⁺ 3 mA	mA
Supply Current	I _{CC(Low)}	ATS645LSH-I1	4.0	6	8.0	mA
		ATS645LSH-I2	5.9	7	8.4	mA
	I _{CC(High)}	ATS645LSH-I1	12.0	14.0	16.0	mA
		ATS645LSH-I2	11.8	14.0	16.8	mA
Supply Current Ratio	I _{CC(High)} / I _{CC(Low)}	Ratio of high current to low current	1.85	–	3.05	–
POWER-ON STATE CHARACTERISTICS						
Power-On State	POS	t > t _{PO}	–	I _{CC(High)}	–	–
Power-On Time ³	t _{PO}	Target gear speed < 100 rpm	–	1	2	ms
OUTPUT STAGE						
Output Slew Rate ⁴	dI/dt	R _{LOAD} = 100 Ω, C _{LOAD} = 10 pF	–	10	–	mA/μs

Continued on the next page.

OPERATING CHARACTERISTICS (continued) using reference target 60-0, T_A and V_{CC} within specification, unless otherwise noted						
Characteristic	Symbol	Test Conditions	Min.	Typ. ¹	Max.	Units
SWITCHPOINT CHARACTERISTICS						
Rotation Speed	S_{ROT}	Reference Target 60-0	0	–	8,000	rpm
Analog Signal Bandwidth	BW	Equivalent to $f - 3dB$	20	40	–	kHz
Operate Point	B_{OP}	Transitioning from $I_{CC(High)}$ to $I_{CC(Low)}$; positive peak referenced; $AG < AG_{MAX}$	–	120	–	mV
Release Point	B_{RP}	Transitioning from $I_{CC(Low)}$ to $I_{CC(High)}$; negative peak referenced; $AG < AG_{MAX}$	–	120	–	mV
CALIBRATION						
Initial Calibration	C_1	Quantity of rising output (current) edges required for accurate edge detection	–	–	3	Edge
DAC CHARACTERISTICS						
Allowable User-Induced Differential Offset		Output switching only; may not meet datasheet specifications	–60	–	60	G
FUNCTIONAL CHARACTERISTICS⁵						
Operational Air Gap Range ⁶	AG	ΔDC within specification	0.5	–	2.75	mm
Maximum Operational Air Gap Range	$AG_{OP(max)}$	Output switching (no missed edges); ΔDC not guaranteed	–	–	3	mm
Duty Cycle Variation ⁷	ΔDC	Wobble < 0.5mm; Typical value at $AG = 1.5$ mm, for max., min., AG within specification	43	53	63	%
Operating Magnetic Flux Density Differential ⁸	$B_{AG(p-p)}$	Operating within specification	30	–	1000	G
Minimum Operating Signal	$Sig_{OP(min)}$	Output switching (no missed edges); ΔDC not guaranteed	20	–	–	G

¹Typical values are at $T_A = 25^\circ C$ and $V_{CC} = 12$ V. Performance may vary for individual units, within the specified maximum and minimum limits.

²Maximum voltage must be adjusted for power dissipation and junction temperature; see *Power Derating* section.

³Power-On Time includes the time required to complete the internal automatic offset adjust. The DACs are then ready for peak acquisition.

⁴ dI is the difference between 10% of $I_{CC(Low)}$ and 90% of $I_{CC(High)}$, and dt is time period between those two points.

Note: dI/dt is dependent upon the value of the bypass capacitor, if one is used.

⁵Functional characteristics valid only if magnetic offset is within the specified range for Allowable User Induced Differential Offset.

⁶AG is dependent on the available magnetic field. The available field is dependent on target geometry and material, and should be independently characterized. The field available from the reference target is given in the reference target parameter section of the datasheet.

⁷Duty cycle specification may not be met if the magnetic signal during the calibration period is not representative of the installation air gap.

⁸In order to remain in specification, the magnetic gradient must induce an operating signal greater than the minimum value specified. This includes the effect of target wobble.

REFERENCE TARGET, 60-0 (60 Tooth Target)

Characteristics	Symbol	Test Conditions	Typ.	Units	Symbol Key
Outside Diameter	D_o	Outside diameter of target	120	mm	
Face Width	F	Breadth of tooth, with respect to branded face	6	mm	
Circular Tooth Length	t	Length of tooth, with respect to branded face; measured at D_o	3	mm	
Circular Valley Length	t_v	Length of valley, with respect to branded face; measured at D_o	3	mm	
Tooth Whole Depth	h_t		3	mm	
Material		Low Carbon Steel	-	-	

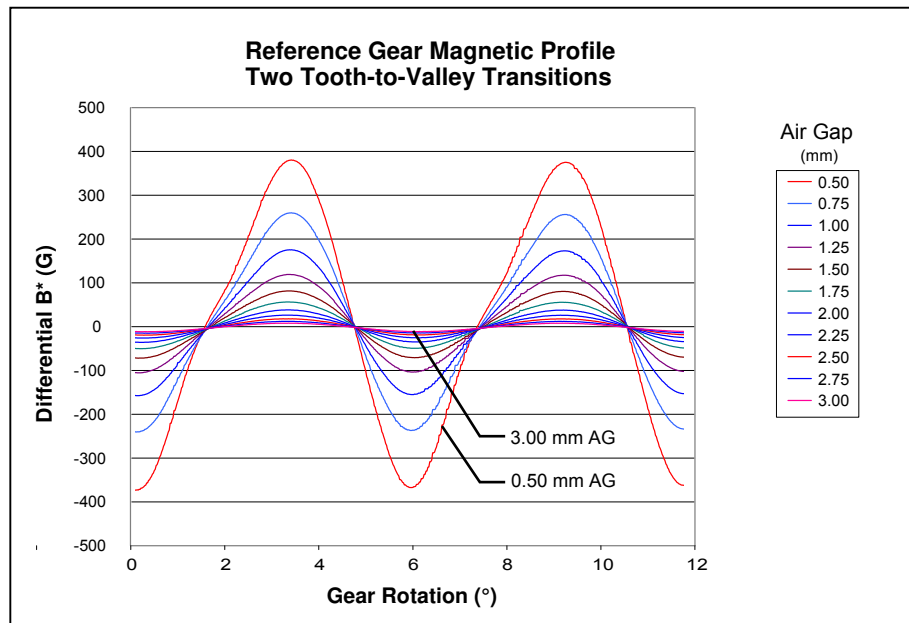
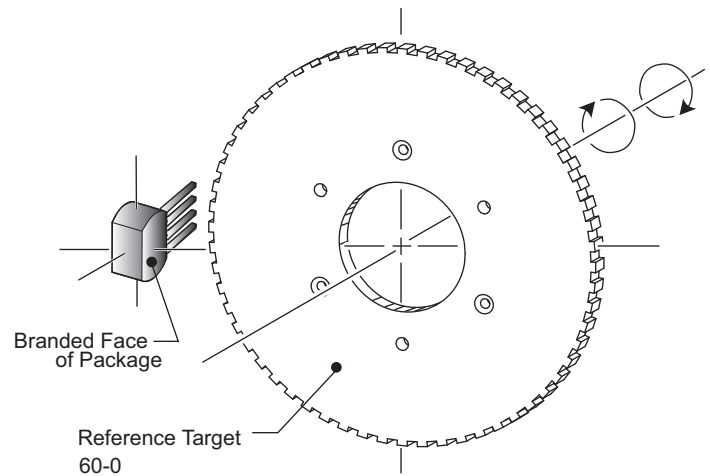
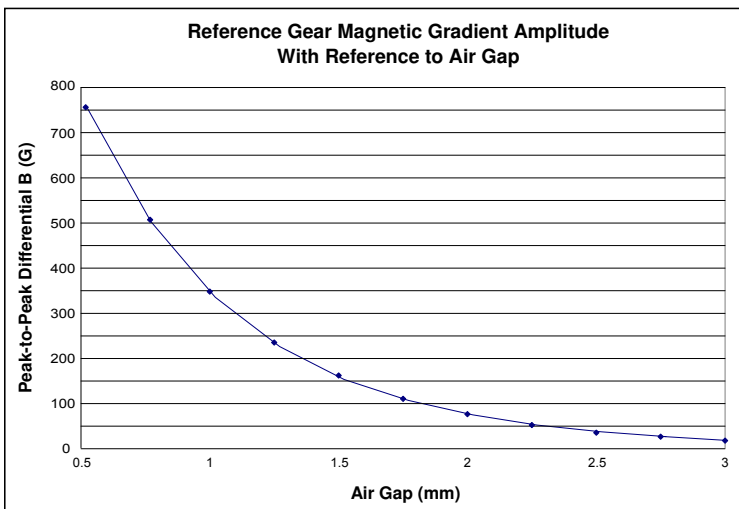

*Differential B corresponds to the calculated difference in the magnetic field as sensed simultaneously at the two Hall elements in the device ($B_{DIFF} = B_{E1} - B_{E2}$).

Characteristic Data

I1 Trim

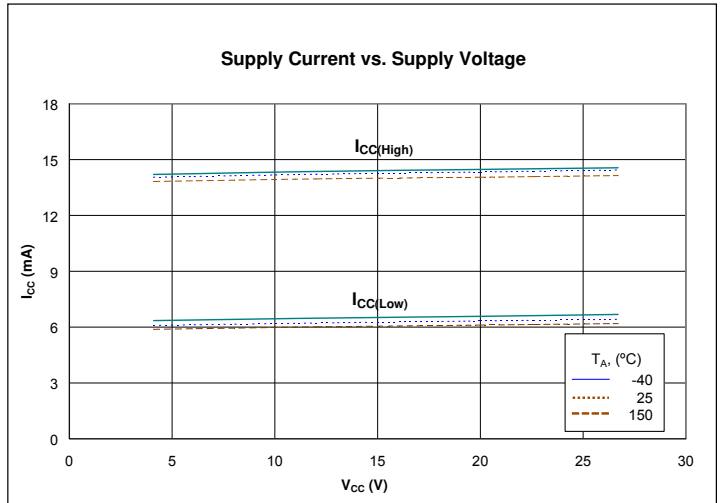
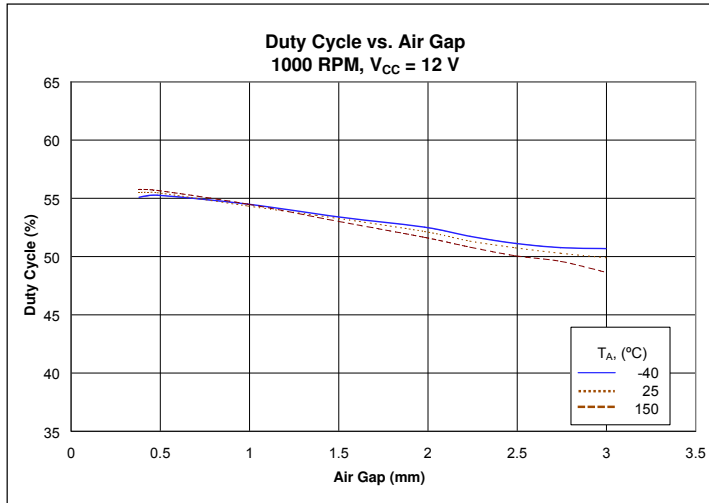
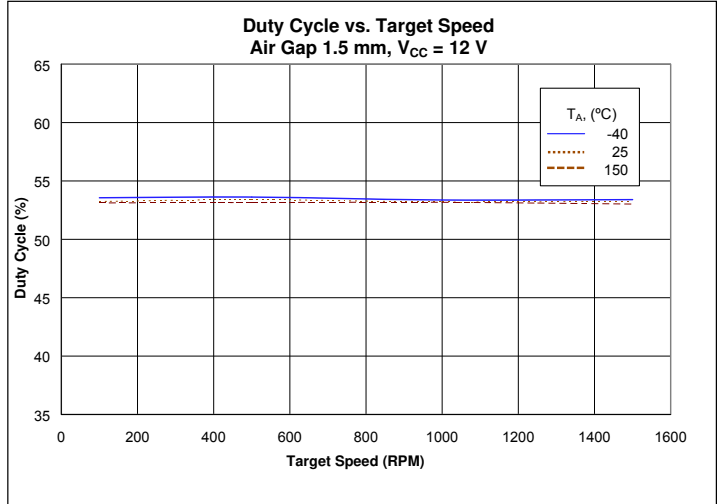
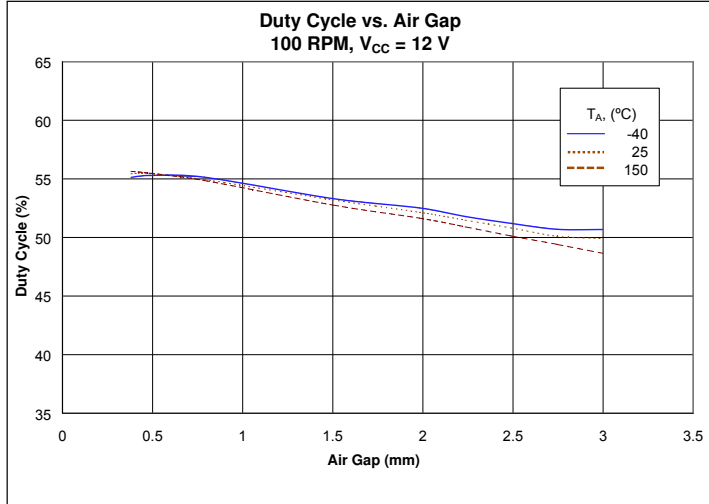

THERMAL CHARACTERISTICS may require derating at maximum conditions, see application information

CHARACTERISTIC	Symbol	TEST CONDITIONS*	Value	Units
Package Thermal Resistance	$R_{\theta JA}$	Single-layer PCB with copper limited to solder pads	126	$^{\circ}\text{C}/\text{W}$
		Two-layer PCB with 3.8 in. ² of copper area on each side connected with thermal vias and to device ground pin	84	$^{\circ}\text{C}/\text{W}$

*Additional information is available on the Allegro Web site.

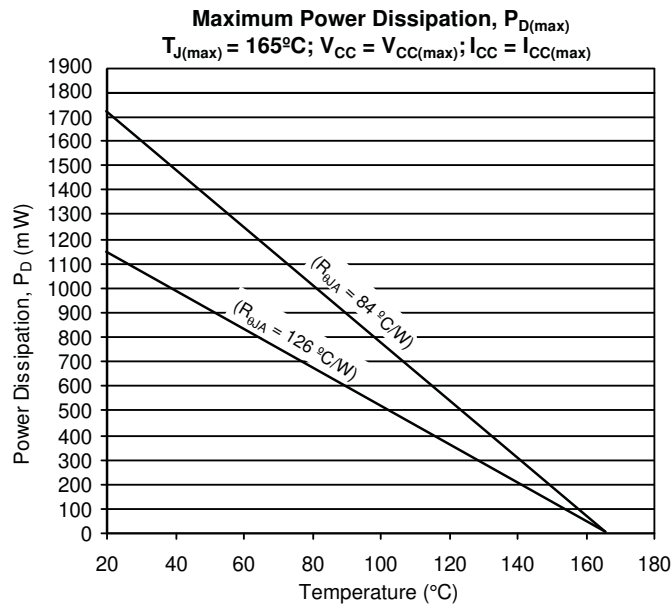
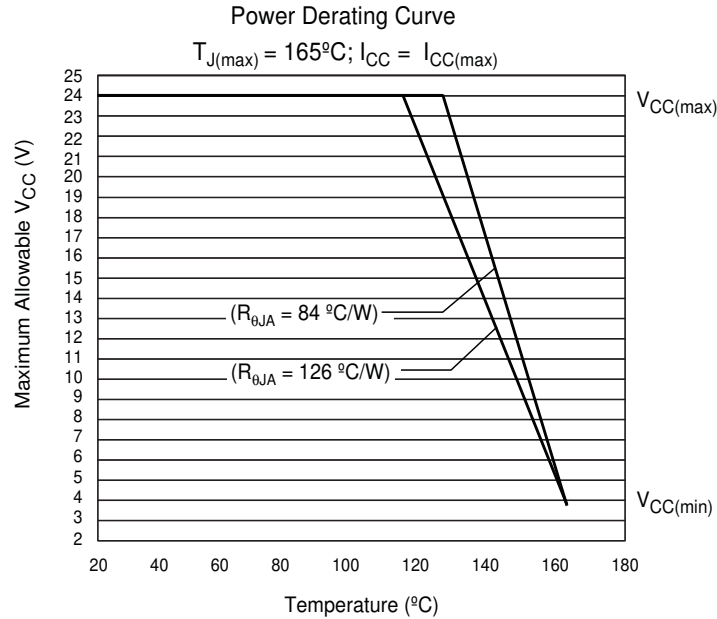

Functional Description

Hall Technology

The gear tooth sensor IC subassembly contains a single-chip differential Hall effect sensor IC, an optimized samarium cobalt pellet, and a flat ferrous pole piece. The Hall IC supports two Hall elements, which sense the magnetic profile of the ferromagnetic target simultaneously, but at different points (spaced at a 1.5 mm pitch), generating a differential internal analog voltage (V_{PROC}) that is processed for precise switching of the digital output signal.

The Hall IC is self-calibrating and also possesses a temperature compensated amplifier and offset cancellation circuitry. Its voltage regulator provides supply noise rejection throughout the operating voltage range. Changes in temperature do not greatly affect this device due to the stable amplifier design and the offset rejection circuitry. The Hall transducers and signal processing electronics are integrated on the same silicon substrate, using a proprietary BiCMOS process.

Target Profiling

An operating device is capable of providing digital information that is representative of the mechanical features on a rotating target. The waveform diagram shown in figure 3 presents the automatic translation of the mechanical profile, through the magnetic profile that it induces, to the digital output signal of the IC.

Output Polarity

Figure 3 shows the output polarity for the orientation of target and package shown in figure 2. The target direction of rotation shown is: perpendicular to the leads, across the face of the device, from the pin 1 side to the pin 4 side. This results in the IC output switching from high, $I_{CC(High)}$, to low $I_{CC(Low)}$, as the leading edge of a tooth (a rising mechanical edge, as detected by the IC) passes the package face. In this configuration, the device output current switches to its low polarity when a tooth is the target feature nearest to the package. If the direction of rotation is reversed, then the output polarity inverts.

Note that output voltage polarity is dependent on the position of the sense resistor, R_{SENSE} (see figure 4).

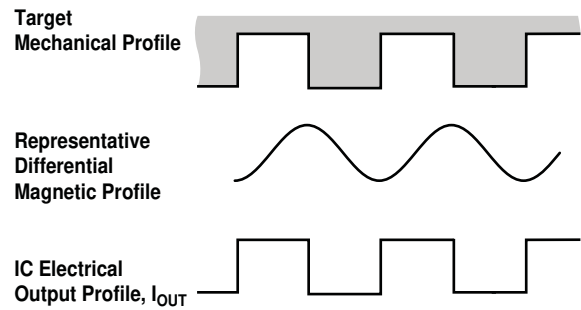

Figure 3. Output Profile of a ferrous target for the polarity indicated in figure 2.

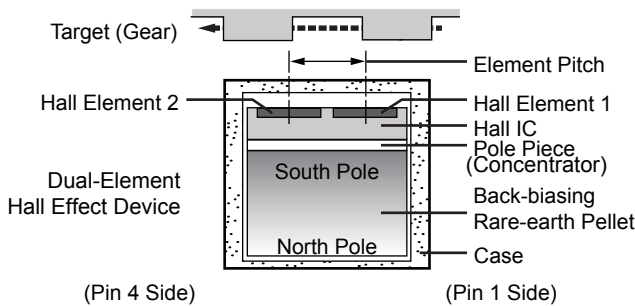

Figure 1. Relative motion of the target is detected by the dual Hall elements mounted on the Hall IC.

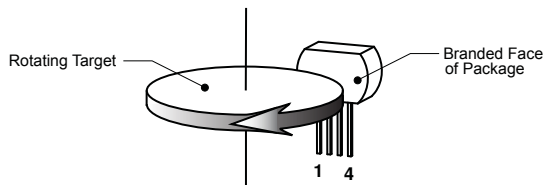

Figure 2. This left-to-right (pin 1 to pin 4) direction of target rotation results in a low output signal when a tooth of the target gear is nearest the face of the package (see figure 3). A right-to-left (pin 4 to pin 1) rotation inverts the output signal polarity.

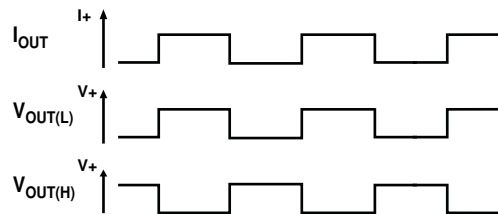
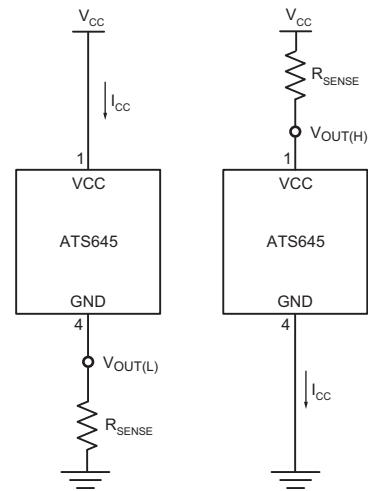

Figure 4: Voltages profiles for high side and low side two-wire sensing.

Automatic Gain Control (AGC)

This feature allows the device to operate with an optimal internal electrical signal, regardless of the air gap (within the AG specification). During calibration, the device determines the peak-to-peak amplitude of the signal generated by the target. The gain of the IC is then automatically adjusted. Figure 5 illustrates the effect of this feature.

Automatic Offset Adjust (AOA)

The AOA is patented circuitry that automatically cancels the effects of chip, magnet, and installation offsets. (For capability, see Dynamic Offset Cancellation, in the Operating Characteristics table.) This circuitry is continuously active, including both during calibration mode and running mode, compensating for any offset drift. Continuous operation also allows it to compen-

sate for offsets induced by temperature variations over time.

Digital Peak Detection

A digital DAC tracks the internal analog voltage signal V_{PROC} , and is used for holding the peak value of the internal analog signal. In the example shown in figure 6, the DAC would first track up with the signal and hold the upper peak's value. When V_{PROC} drops below this peak value by B_{OP} , the device hysteresis, the output would switch and the DAC would begin tracking the signal downward toward the negative V_{PROC} peak. Once the DAC acquires the negative peak, the output will again switch states when V_{PROC} is greater than the peak by the value B_{RP} . At this point, the DAC tracks up again and the cycle repeats. The digital tracking of the differential analog signal allows the IC to achieve true zero-speed operation.

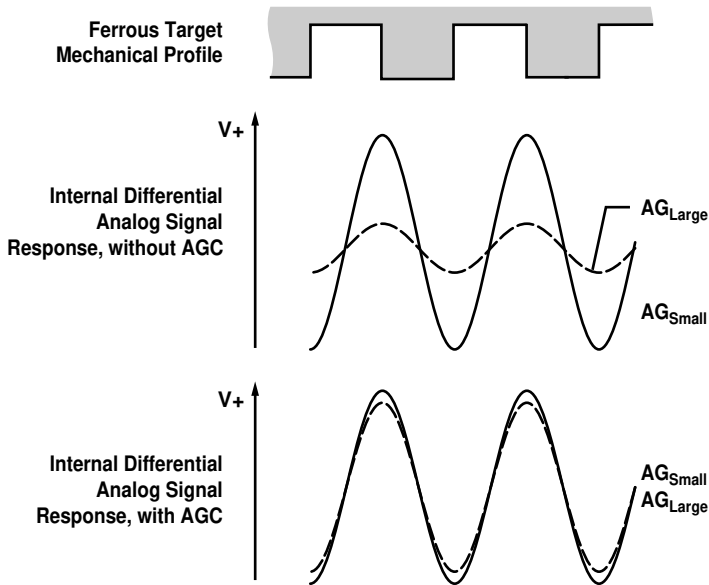

Figure 5. Automatic Gain Control (AGC). The AGC function corrects for variances in the air gap. Differences in the air gap affect the magnetic gradient, but AGC prevents that from affecting device performance, as shown in the lowest panel.

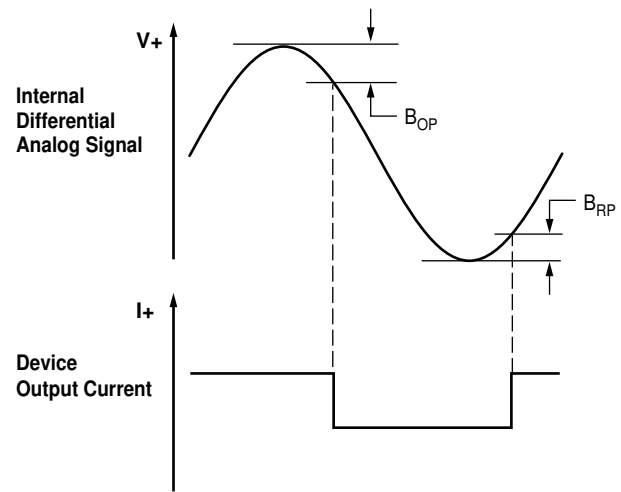

Figure 6: Peak Detecting Switchpoint Detail

Power Supply Protection

The device contains an on-chip regulator and can operate over a wide V_{CC} range. For devices that need to operate from an unregulated power supply, transient protection must be added externally. For applications using a regulated line, EMI/RFI protection may still be required. Contact Allegro MicroSystems for information on the circuitry needed for compliance with various EMC specifications. Refer to figure 7 for an example of a basic application circuit.

Undervoltage Lockout

When the supply voltage falls below the undervoltage lockout

voltage, $V_{CC(UV)}$, the device enters Reset, where the output state returns to the Power-On State (POS) until sufficient V_{CC} is supplied. I_{CC} levels may not meet datasheet limits when $V_{CC} < V_{CC(min)}$.

Assembly Description

This device is integrally molded into a plastic body that has been optimized for size, ease of assembly, and manufacturability. High operating temperature materials are used in all aspects of construction.

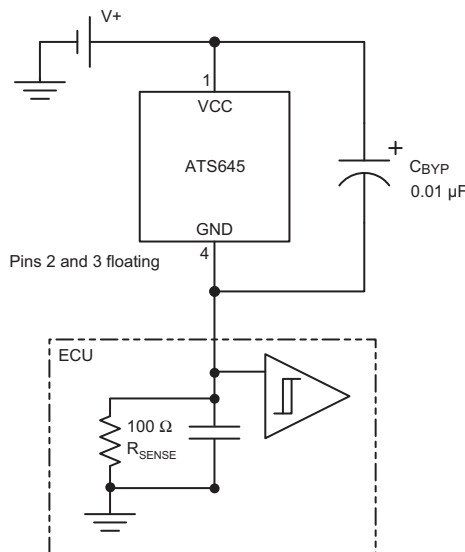

Figure 7: Typical Application Circuit

DEVICE OPERATION

Each operating mode is described in detail below.

Power-On

When power ($V_{CC} > V_{CCMIN}$) is applied to the device, a short period of time is required to power the various portions of the IC. During this period, the ATS645 is guaranteed to power-on in the high current state, $I_{CC(High)}$.

Initial Offset Adjust

The IC initially cancels the effects of chip, magnet, and installation offsets. Once offsets have been cancelled, the digital tracking DAC is ready to track the signal and provide output switching. The period of time required for both Power-On and Initial Offset Adjust is defined as the Power-On Time.

Calibration Mode

The calibration mode allows the IC to automatically select the proper signal gain and continue to adjust for offsets. The AGC is active, and selects the optimal signal gain based on the amplitude of the V_{PROC} signal. Following each adjustment to the AGC DAC, the Offset DAC is also adjusted to ensure the

internal analog signal is properly centered.

During this mode, the tracking DAC is active and output switching occurs, but the duty cycle is not guaranteed to be within specification.

Diagnostics

The regulated current output is configured for two wire applications, requiring one less wire for operation than do switches with the more traditional open-collector output. Additionally, the system designer inherently gains diagnostics because there is always output current flowing, which should be in either of two narrow ranges. Any current level not within these ranges indicates a fault condition.

Running Mode

After the initial calibration period, C_1 , during which a signal gain is established, the device moves to Running mode. During Running mode, the IC tracks the input signal and gives an output edge for every peak of the signal. AOA remains active to compensate for any offset drift over time.

Power Derating

The device must be operated below the maximum junction temperature of the device, $T_{J(max)}$. Under certain combinations of peak conditions, reliable operation may require derating supplied power or improving the heat dissipation properties of the application. This section presents a procedure for correlating factors affecting operating T_J . (Thermal data is also available on the Allegro MicroSystems Web site.)

The Package Thermal Resistance, $R_{\theta JA}$, is a figure of merit summarizing the ability of the application and the device to dissipate heat from the junction (die), through all paths to the ambient air. Its primary component is the Effective Thermal Conductivity, K , of the printed circuit board, including adjacent devices and traces. Radiation from the die through the device case, $R_{\theta JC}$, is relatively small component of $R_{\theta JA}$. Ambient air temperature, T_A , and air motion are significant external factors, damped by overmolding.

The effect of varying power levels (Power Dissipation, P_D), can be estimated. The following formulas represent the fundamental relationships used to estimate T_J , at P_D .

$$P_D = V_{IN} \times I_{IN} \quad (1)$$

$$\Delta T = P_D \times R_{\theta JA} \quad (2)$$

$$T_J = T_A + \Delta T \quad (3)$$

For example, given common conditions such as: $T_A = 25^\circ C$, $V_{CC} = 12 V$, $I_{CC} = 4 mA$, and $R_{\theta JA} = 140^\circ C/W$, then:

$$P_D = V_{CC} \times I_{CC} = 12 V \times 4 mA = 48 mW$$

$$\Delta T = P_D \times R_{\theta JA} = 48 mW \times 140^\circ C/W = 7^\circ C$$

$$T_J = T_A + \Delta T = 25^\circ C + 7^\circ C = 32^\circ C$$

A worst-case estimate, $P_{D(max)}$, represents the maximum allowable power level ($V_{CC(max)}$, $I_{CC(max)}$), without exceeding $T_{J(max)}$, at a selected $R_{\theta JA}$ and T_A .

Example: Reliability for V_{CC} at $T_A = 150^\circ C$, package SH (I1 trim), using minimum-K PCB

Observe the worst-case ratings for the device, specifically: $R_{\theta JA} = 126^\circ C/W$, $T_{J(max)} = 165^\circ C$, $V_{CC(max)} = 24 V$, and $I_{CC(max)} = 16 mA$.

Calculate the maximum allowable power level, $P_{D(max)}$. First, invert equation 3:

$$\Delta T_{max} = T_{J(max)} - T_A = 165^\circ C - 150^\circ C = 15^\circ C$$

This provides the allowable increase to T_J resulting from internal power dissipation. Then, invert equation 2:

$$P_{D(max)} = \Delta T_{max} \div R_{\theta JA} = 15^\circ C \div 126^\circ C/W = 119 mW$$

Finally, invert equation 1 with respect to voltage:

$$V_{CC(est)} = P_{D(max)} \div I_{CC(max)} = 119 mW \div 16 mA = 7 V$$

The result indicates that, at T_A , the application and device can dissipate adequate amounts of heat at voltages $\leq V_{CC(est)}$.

Compare $V_{CC(est)}$ to $V_{CC(max)}$. If $V_{CC(est)} \leq V_{CC(max)}$, then reliable operation between $V_{CC(est)}$ and $V_{CC(max)}$ requires enhanced $R_{\theta JA}$. If $V_{CC(est)} \geq V_{CC(max)}$, then operation between $V_{CC(est)}$ and $V_{CC(max)}$ is reliable under these conditions.

Package SH SIP

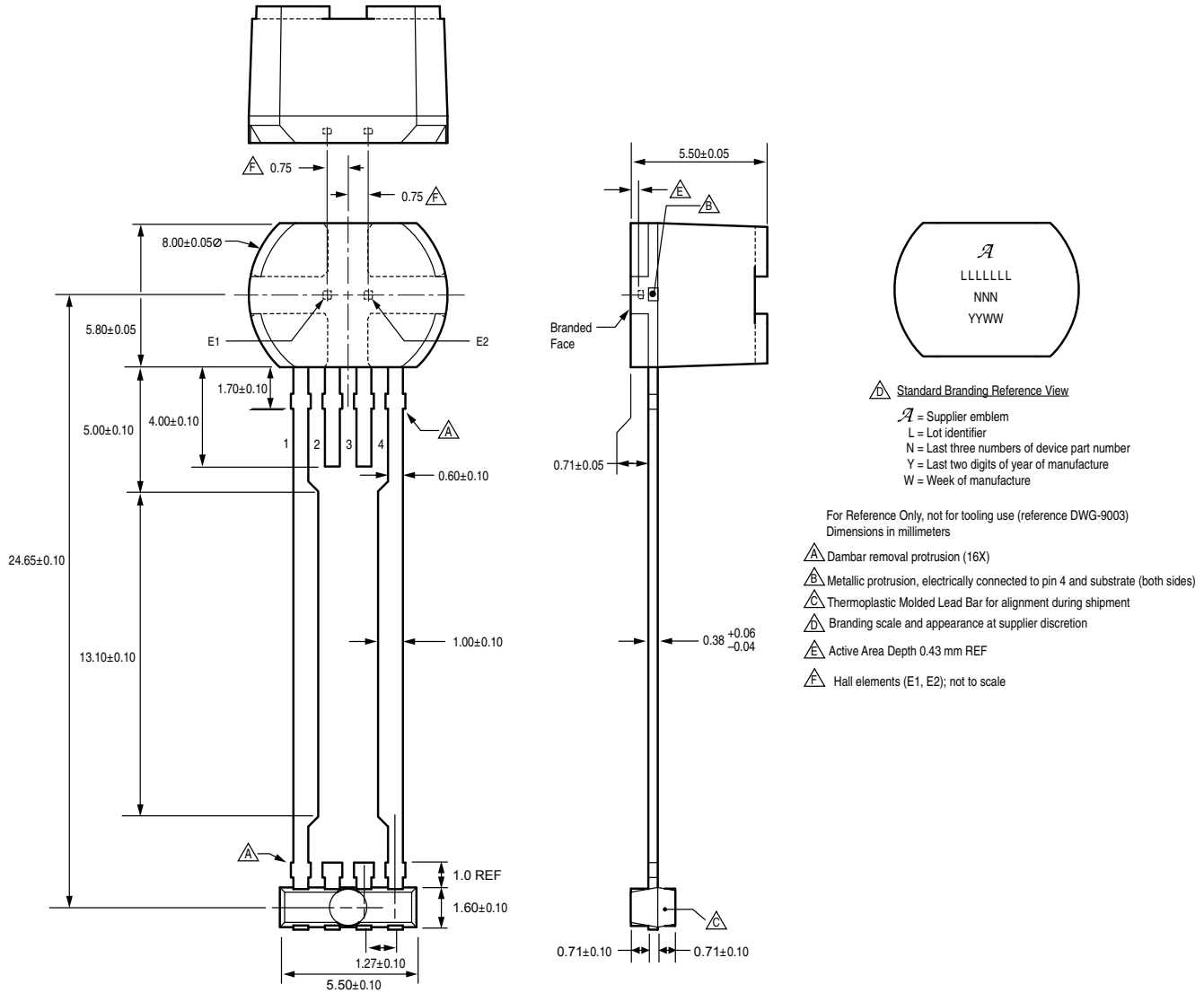

Copyright ©2004-2009, Allegro MicroSystems, Inc.

The products described herein are manufactured under one or more of the following U.S. patents: 5,264,783; 5,389,889; 5,442,283; 5,517,112; 5,581,179; 5,619,137; 5,621,319; 5,650,719; 5,686,894; 5,694,038; 5,729,130; 5,917,320; 6,091,239; 6,100,680; 6,232,768; 6,242,908; 6,265,865; 6,297,627; 6,525,531; 6,690,155; 6,693,419; 6,919,720; 7,046,000; 7,053,674; 7,138,793; 7,199,579; 7,253,614; 7,365,530; 7,368,904; or other patents pending.

Allegro MicroSystems, Inc. reserves the right to make, from time to time, such departures from the detail specifications as may be required to permit improvements in the performance, reliability, or manufacturability of its products. Before placing an order, the user is cautioned to verify that the information being relied upon is current.

Allegro's products are not to be used in life support devices or systems, if a failure of an Allegro product can reasonably be expected to cause the failure of that life support device or system, or to affect the safety or effectiveness of that device or system.

The information included herein is believed to be accurate and reliable. However, Allegro MicroSystems, Inc. assumes no responsibility for its use; nor for any infringement of patents or other rights of third parties which may result from its use.

For the latest version of this document, visit our website:

www.allegromicro.com

