



Chipsmall Limited consists of a professional team with an average of over 10 year of expertise in the distribution of electronic components. Based in Hongkong, we have already established firm and mutual-benefit business relationships with customers from,Europe,America and south Asia,supplying obsolete and hard-to-find components to meet their specific needs.

With the principle of “Quality Parts,Customers Priority,Honest Operation,and Considerate Service”,our business mainly focus on the distribution of electronic components. Line cards we deal with include Microchip,ALPS,ROHM,Xilinx,Pulse,ON,Everlight and Freescale. Main products comprise IC,Modules,Potentiometer,IC Socket,Relay,Connector.Our parts cover such applications as commercial,industrial, and automotives areas.

We are looking forward to setting up business relationship with you and hope to provide you with the best service and solution. Let us make a better world for our industry!



Contact us

Tel: +86-755-8981 8866 Fax: +86-755-8427 6832

Email & Skype: info@chipsmall.com Web: www.chipsmall.com

Address: A1208, Overseas Decoration Building, #122 Zhenhua RD., Futian, Shenzhen, China



Two-Wire, Differential, Vibration Resistant Sensor IC with Speed and Direction Output

Features and Benefits

- Two-wire, pulse width output protocol
- Digital output representing target profile
- Speed and direction information of target
- Vibration tolerance
 - Small signal lockout for small amplitude vibration
 - Proprietary vibration detection algorithms for large amplitude vibration
- Air gap independent switch points
- Large operating air gap capability
- Undervoltage lockout
- True zero-speed operation
- Wide operating voltage range
- Single chip sensing IC for high reliability
- Robust test coverage capability with Scan Path and IDDQ measurement

Package: 4-pin SIP (suffix SH)



Not to scale

Description

The ATS692LSH is an optimized Hall-effect integrated circuit (IC) and rare earth pellet combination that provides a user-friendly solution for direction detection and true zero-speed, digital gear tooth sensing. The small package can be easily assembled and used in conjunction with a wide variety of gear tooth sensing applications.

The IC employs patented algorithms for the special operational requirements of automotive transmission applications. The speed and direction of the target are communicated through a variable pulse width output protocol. The ATS692 is particularly adept at handling vibration without sacrificing maximum air gap capability or creating any erroneous direction information. Even higher angular vibration caused by engine cranking is completely rejected by the device. The advanced vibration detection algorithm systematically calibrates the sensor IC on the initial teeth of true target rotation and not on vibration, always guaranteeing an accurate signal in running mode.

Advanced signal processing and innovative algorithms make the ATS692 an ideal solution for a wide range of speed and direction sensing needs.

This device is available in a lead (Pb) free 4-pin SIP package with a 100% matte tin plated leadframe.

Functional Block Diagram

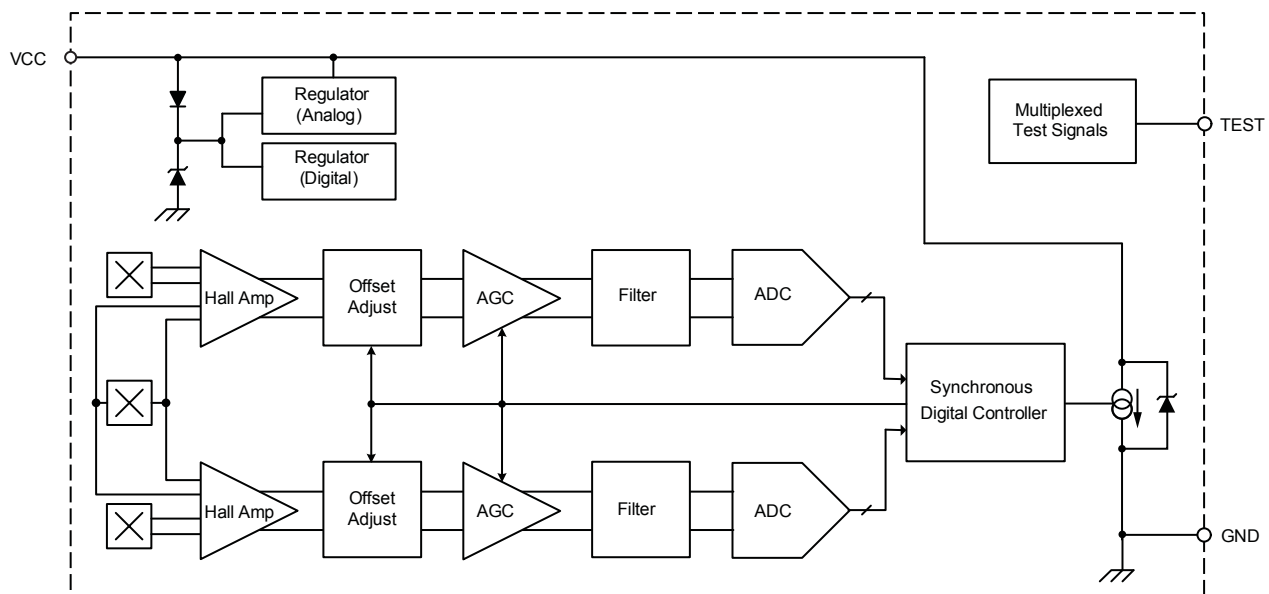

ATS692LSH(RSNPH)

Two-Wire, Differential, Vibration Resistant Sensor IC with Speed and Direction Output

Selection Guide

Part Number	Packing*	$t_{w(ND)}$ (nom)	Direction Change Function	Vibration Immunity (Running Mode)
ATS692LSHTN-RSNPH-T	800 pieces per reel	180 μ s	$t_{w(ND)}$ until direction validated	T_{TARGET}



*Contact Allegro™ for additional packing options.

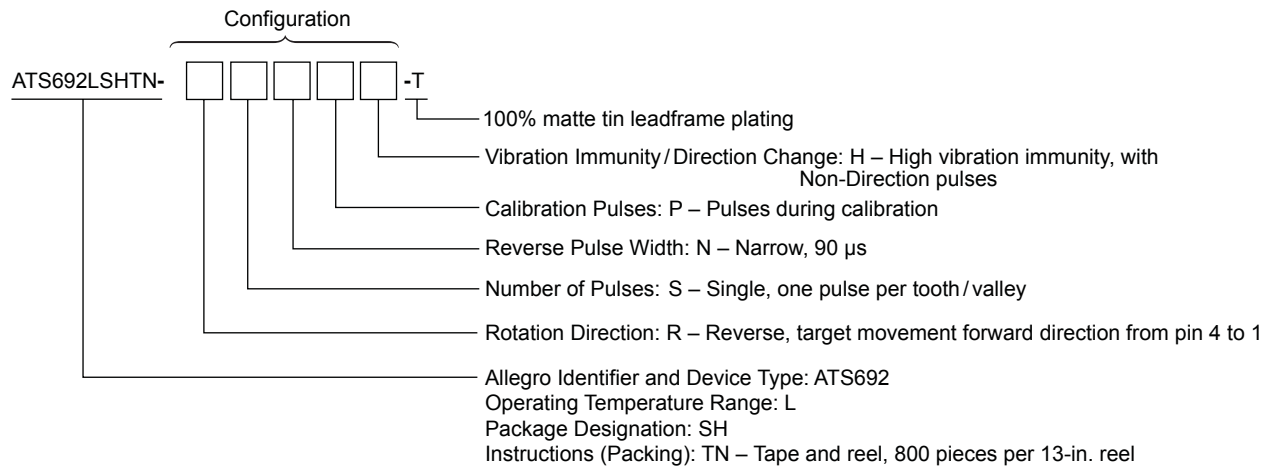

Absolute Maximum Ratings

Characteristic	Symbol	Notes	Rating	Unit
Supply Voltage	V_{CC}	Refer to Power Derating section	28	V
Reverse Supply Voltage	V_{RCC}		-18	V
Operating Ambient Temperature	T_A	L temperature range	-40 to 150	°C
Maximum Junction Temperature	$T_J(max)$		165	°C
Storage Temperature	T_{stg}		-65 to 170	°C

Pin-out Diagram

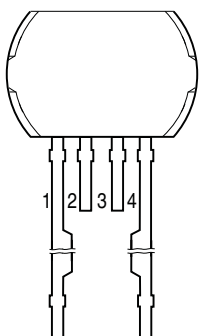

Terminal List Table

Number	Name	Function
1	VCC	Supply voltage
2	TEST	Test pin: float *
3	TEST	Test pin: float *
4	GND	Ground

*Connection of TEST to VCC and/or GND may cause undesired additional current consumption in the IC.

OPERATING CHARACTERISTICS Valid at throughout full operating and temperature ranges; using Reference Target 60-0; unless otherwise specified

Characteristic	Symbol	Test Conditions	Min.	Typ. ¹	Max.	Unit
General Electrical Characteristics						
Supply Voltage ²	V _{CC}	Operating, T _J < T _J (max)	4.0	–	24	V
Under Voltage Lockout	V _{CC(UV)}	V _{CC} 0 → 5 V or 5 → 0 V	–	3.6	3.95	V
Reverse Supply Current ³	I _{RCC}	V _{CC} = V _{RCC} (max)	–	–	–10	mA
Supply Zener Clamp Voltage	V _{Z(SUPPLY)}	I _{CC} = I _{CC} (max) + 3 mA, T _A = 25°C	28	–	–	V
Supply Current	I _{CC} (LOW)	Low-current state (Running mode)	5.0	–	8.0	mA
	I _{CC} (HIGH)	High-current state (Running mode)	12.0	–	16.0	mA
	I _{CC(SU)} (LOW)	Startup current level (Power-On mode)	5.0	–	8.5	mA
	I _{CC(SU)} (HIGH)	High-current state (Calibration)	12.0	–	16.5	mA
Supply Current Ratio	I _{CC} (HIGH) / I _{CC} (LOW)	Measured as ratio of high current to low current	1.9	–	–	–
Test Pins Zener Clamp Voltage ⁴	V _{Z(TEST)}		–	6	–	V
Output Stage						
Output Slew Rate	SR _{OUT}	R _L = 100 Ω, C _L = 10 pF; I _{CC} (HIGH) → I _{CC} (LOW), I _{CC} (LOW) → I _{CC} (HIGH), 10% to 90% points	7.0	16	–	mA / μs
Output Pulse Characteristics⁵						
Pulse Width (Forward Rotation)	t _w (FWD)		38	45	52	μs
Pulse Width (Reverse Rotation)	t _w (REV)		76	90	104	μs
Pulse Width (Non-Direction)	t _w (ND)		153	180	207	μs
General Operating Characteristics						
Operate Point	B _{OP}	% of peak-to-peak V _{PROC}	–	69	–	%
Release Point	B _{RP}	% of peak-to-peak V _{PROC}	–	31	–	%
Operating Frequency (Forward Rotation)	f _{FWD}		0	–	12	kHz
Operating Frequency (Reverse Rotation) ⁶	f _{REV}		0	–	7	kHz
Operating Frequency (Non-Direction Pulses) ⁶	f _{ND}		0	–	4	kHz
DAC Characteristics						
Allowable User-Induced Offset	B _{OFFSET}	Magnitude valid for both differential magnetic channels	–60	–	60	G
Performance Characteristics						
Air Gap Range	AG	Using Allegro Reference Target 60-0	0.5	–	2.75	mm
Vibration Immunity (Startup)	err _{VIB(SU)}	See figure 1	T _{TARGET}	–	–	deg.
Vibration Immunity (Running Mode)	err _{VIB}	See figure 1	T _{TARGET}	–	–	deg.

Continued on the next page...

OPERATING CHARACTERISTICS (continued) Valid at throughout full operating and temperature ranges; using Reference Target 60-0; unless otherwise specified

Characteristic	Symbol	Test Conditions	Min.	Typ. ¹	Max.	Unit	
Input Magnetic Characteristics							
Allowable Differential Sequential Signal Variation ⁷	$B_{SEQ(n+1)} / B_{SEQ(n)}$	Signal cycle-to-cycle variation (see figure 2)	0.6	–	–	–	
Calibration							
First Direction Output Pulse ⁸		Amount of target rotation (constant direction) following power-on until first electrical output pulse of either $t_{w(FWD)}$ or $t_{w(REV)}$, see figure 1	AG ≥ 0.5 mm AG < 2.25 mm	–	2 × T_{TARGET}	<3 × T_{TARGET}	deg.
			AG ≥ 2.25 mm AG ≤ 2.75 mm	–	2.5 × T_{TARGET}	<4 × T_{TARGET}	deg.
First Direction Pulse Output Following Direction Change	N_{CD}	Amount of target rotation (constant direction) following event until first electrical output pulse of either $t_{w(FWD)}$ or $t_{w(REV)}$, see figure 1	1 × T_{TARGET}	2 × T_{TARGET}	<3 × T_{TARGET}	deg.	
First Direction Pulse Output Following Running Mode Vibration		Amount of target rotation (constant direction) following event until first electrical output pulse of either $t_{w(FWD)}$ or $t_{w(REV)}$, see figure 1	1 × T_{TARGET}	2 × T_{TARGET}	<3 × T_{TARGET}	deg.	

¹Typical values are at $T_A = 25^\circ\text{C}$ and $V_{CC} = 12\text{ V}$. Performance may vary for individual units, within the specified maximum and minimum limits.

²Maximum voltage must be adjusted for power dissipation and junction temperature; see Power Derating section.

³Negative current is defined as conventional current coming out of (sourced from) the specified device terminal.

⁴Sustained voltages beyond the clamp voltage may cause permanent damage to the IC.

⁵Load circuit is $R_L = 100\ \Omega$ and $C_L = 10\ \text{pF}$. Pulse duration measured at a threshold of $(I_{CC(HIGH)} + I_{CC(LOW)}) / 2$.

⁶Maximums of both Operating Frequency (Reverse Rotation) and Operating Frequency (Non-Direction Pulses) are determined by satisfactory separation of output pulses: $I_{CC(LOW)}$ or $t_{w(FWD)}(\text{min})$. If the customer can resolve lower low-state durations, maximum f_{REV} and f_{ND} may be increased.

⁷If the minimum signal phase separation is not maintained during or after a signal variation event, output may be blanked or non-direction pulses may occur. A signal variation event during power-on may increase the quantity of edges required to get correct direction pulses.

⁸Power-on frequency ≤ 200 Hz. Higher power-on frequencies may require more input magnetic cycles until directional output pulses are achieved.

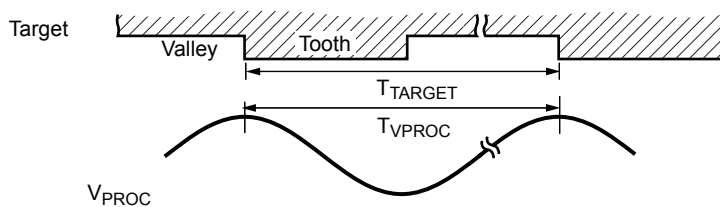

V_{PROC} = the processed analog signal of the sinusoidal magnetic input (per channel)
 T_{TARGET} = period between successive sensed target mechanical edges of the same orientation (either both rising or both falling)

Figure 1. Definition of T_{TARGET}

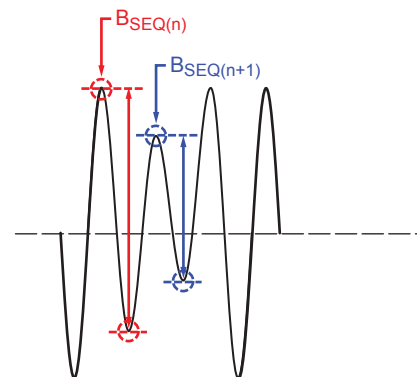
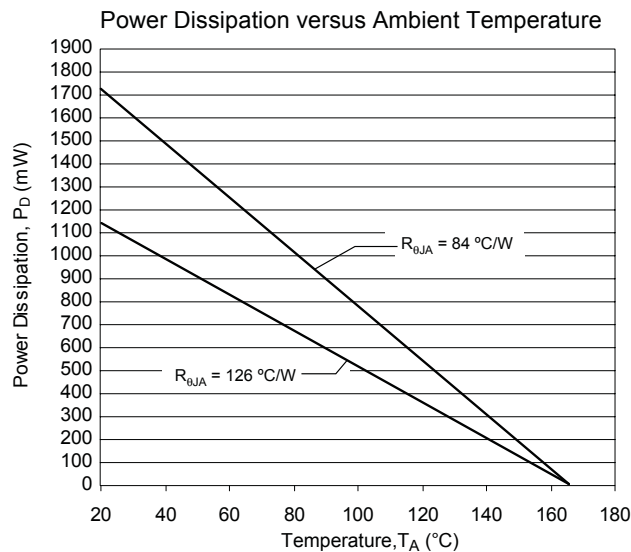
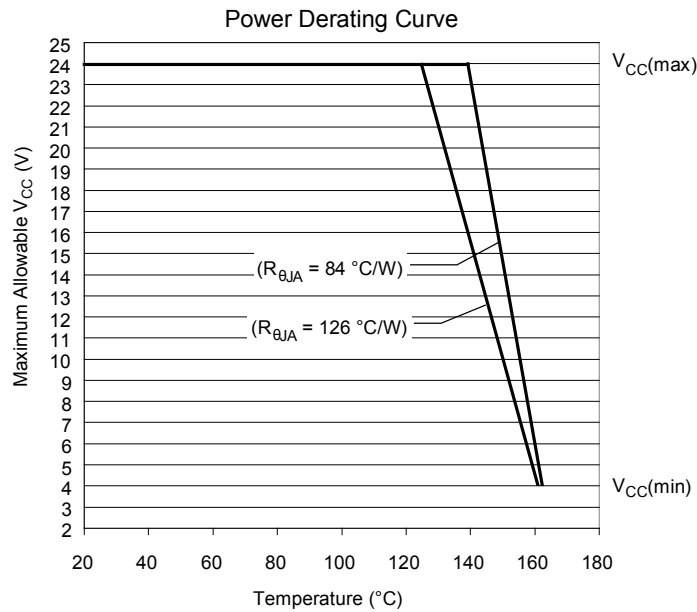

Figure 2. Differential signal variation

Thermal Characteristics may require derating at maximum conditions, see Power Derating section

Characteristic	Symbol	Test Conditions*	Value	Unit
Package Thermal Resistance	$R_{\theta JA}$	Single layer PCB, with copper limited to solder pads	126	$^{\circ}\text{C}/\text{W}$
		Single layer PCB, with copper limited to solder pads and 3.57 in. ² (23.03 cm ²) copper area each side	84	$^{\circ}\text{C}/\text{W}$

*Additional thermal information available on the Allegro website



Reference Target 60-0 (60 Tooth Target)

Characteristics	Symbol	Test Conditions	Typ.	Units	Symbol Key
Outside Diameter	D_o	Outside diameter of target	120	mm	
Face Width	F	Breadth of tooth, with respect to branded face	6	mm	
Angular Tooth Thickness	t	Length of tooth, with respect to branded face	3	deg.	
Angular Valley Thickness	t_v	Length of valley, with respect to branded face	3	deg.	
Tooth Whole Depth	h_t		3	mm	
Material		Low Carbon Steel	-	-	

Reference Gear Magnetic Gradient Amplitude versus Air Gap
Reference Target 60-0

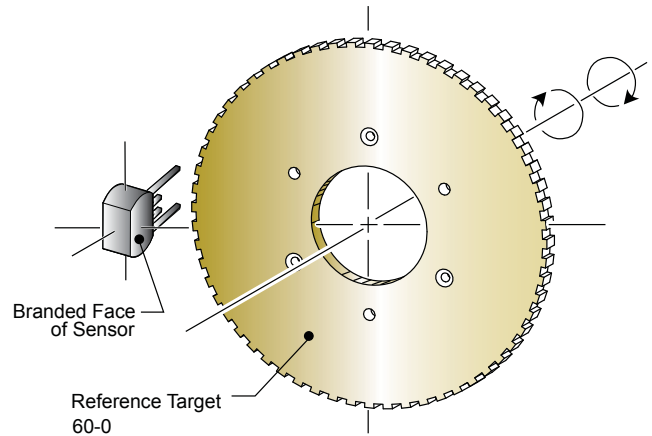
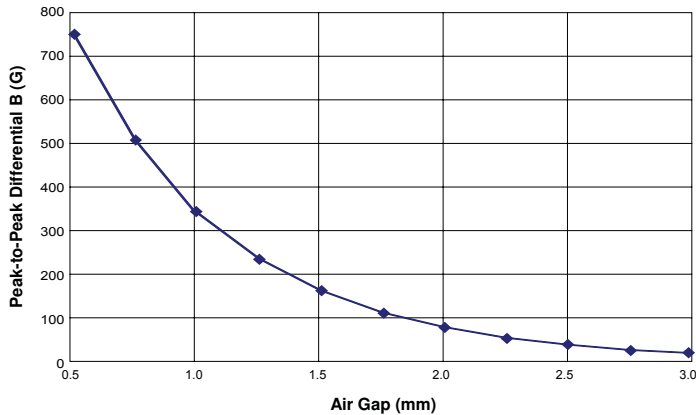

Reference Gear Magnetic Profile
Two Tooth-to-Valley Transitions

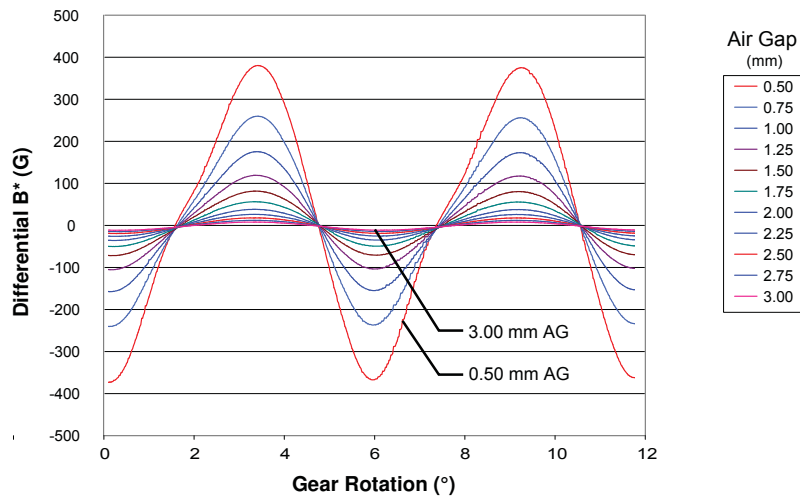

Functional Description

Sensing Technology

The sensor IC contains a single-chip Hall-effect circuit that supports a trio of Hall elements. These elements are used in differential pairs to provide electrical signals containing information regarding edge position and direction of target rotation. The ATS692 is intended for use with ferromagnetic targets.

After proper power is applied to the sensor IC, it is capable of providing digital information that is representative of the magnetic features of a rotating target. The waveform diagrams in figure 3 present the automatic translation of the target profiles, through their induced magnetic profiles, to the digital output signal of the sensor IC.

Direction Detection

The sensor IC compares the relative phase of its two differential channels to determine in which direction the target is moving. The relative switching order is used to determine the direction, which is communicated through the output protocol.

Data Protocol Description

When a target passes in front of the device (opposite the branded face of the package case), the ATS692 generates an output pulse for each tooth of the target. Speed information is provided by the output pulse rate, while direction of target rotation is provided by the duration of the output pulses. The sensor IC can sense target movement in both the forward and reverse directions.

Forward Rotation (see panel A in figure 2) When the target is rotating such that a tooth near the sensor IC passes from pin 4 to pin 1, this is referred to as *forward rotation*. Forward rotation is indicated on the output by a $t_{w(FWD)}$ (45 μ s typical) pulse width.

Reverse Rotation (see panel B in figure 2) When the target is rotating such that a tooth passes from pin 1 to pin 4, it is referred to as *reverse rotation*. Reverse rotation is indicated on the output by pulse widths of $t_{w(REV)}$ (90 μ s typical).

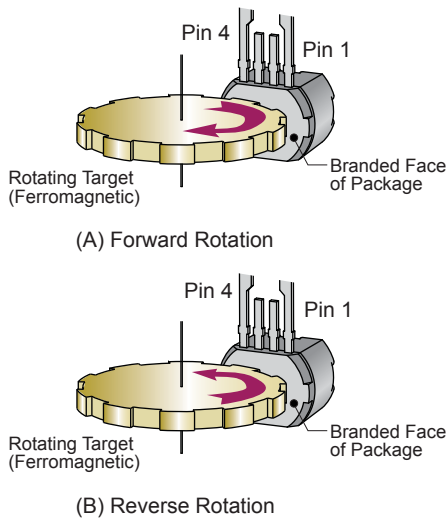

Figure 2. Target rotation

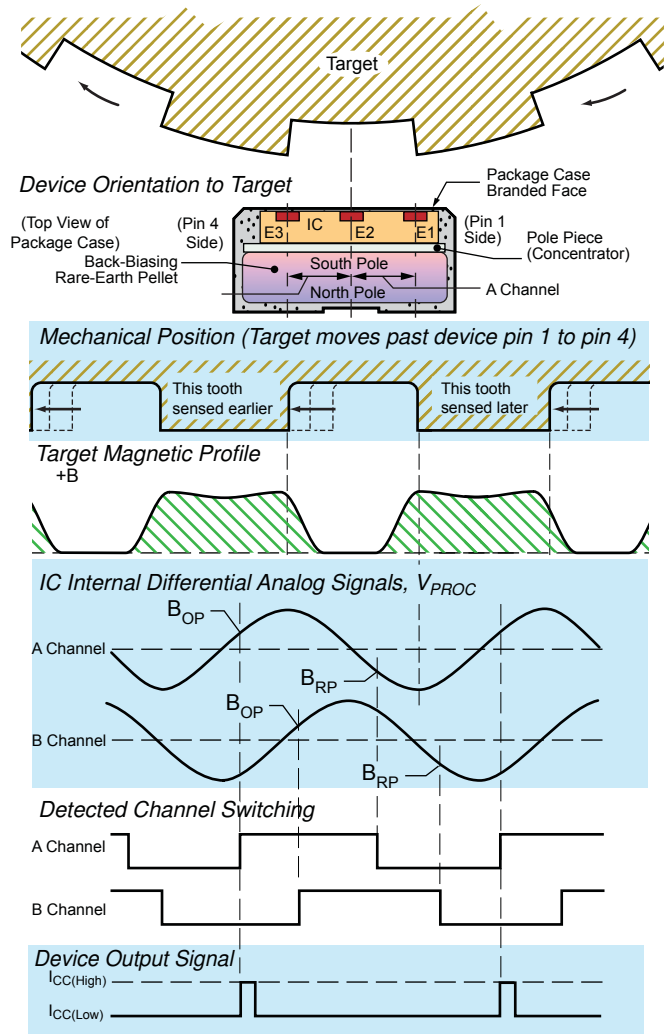

Figure 3. The magnetic profile reflects the features of the target, allowing the sensor IC to present an accurate digital output.

Timing As shown in figure 4, the pulse appears at the output slightly before the sensed magnetic edge traverses the package branded face. For targets in forward rotation, this shift, Δ_{fwd} , results in the pulse corresponding to the valley with the sensed mechanical edge, and for targets in reverse rotation, the shift, Δ_{rev} , results in the pulse corresponding to the tooth with the sensed edge. The sensed mechanical edge that stimulates output pulses is kept the same for both forward and reverse rotation by using only one channel to control output switching.

Direction Validation

Following a direction change in running mode, output pulses have a width of $t_{w(ND)}$ until direction information is validated. An example of the waveforms is shown in figure 5.

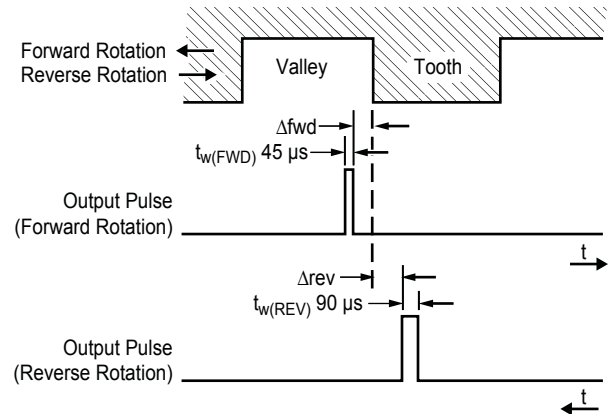

Figure 4. Output protocol

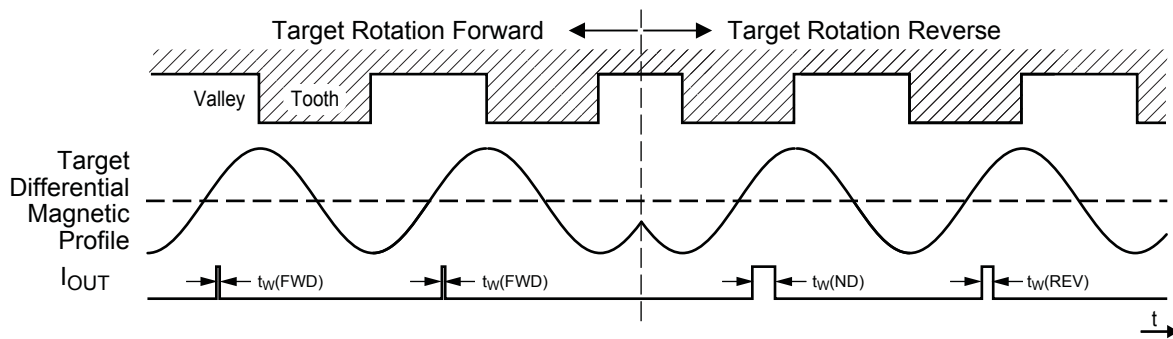

Figure 5. Example of direction change in Running mode

Start-Up Detection / Calibration

When power is applied to the ATS692, the sensor IC internally detects the profile of the target. The gain and offset of the detected signals are adjusted during the calibration period, normalizing the internal signal amplitude for the air gap range of the device.

The Automatic Gain Control (AGC) feature ensures that operational characteristics are isolated from the effects of installation air gap variation.

Automatic Offset Adjustment (AOA) is circuitry that compensates for the effects of chip, magnet, and installation offsets. This circuitry works with the AGC during calibration to adjust V_{PROC} in the internal A-to-D range to allow for acquisition of signal peaks. AOA and AGC function separately on the two

differential signal channels.

Direction information is available after calibration is complete. Output pulses of $t_{w(ND)}$ are supplied during calibration. Figure 6 shows where the first output edges may occur for various starting target phases.

Vibration Detection

Algorithms embedded in the IC digital controller detect the presence of target vibration through analysis of the two magnetic input channels.

In the presence of vibration, output pulses of $t_{w(ND)}$ may occur or no pulses may occur, depending on the amplitude and phase of the vibration (figure 7). Output pulses have a width of $t_{w(ND)}$ until direction information is validated on constant target rotation.

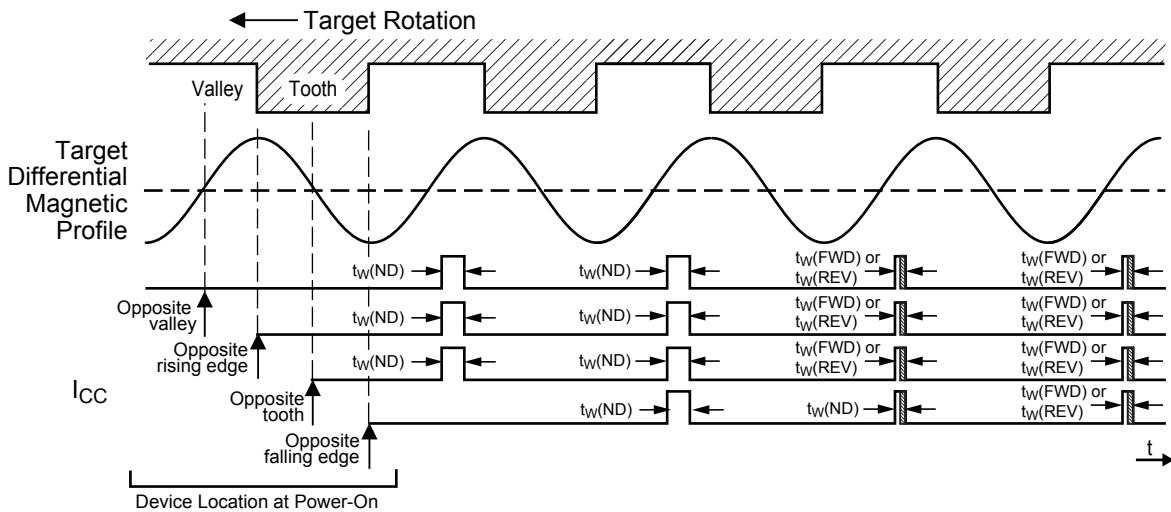

Figure 6. Start-up position effect on first device output switching

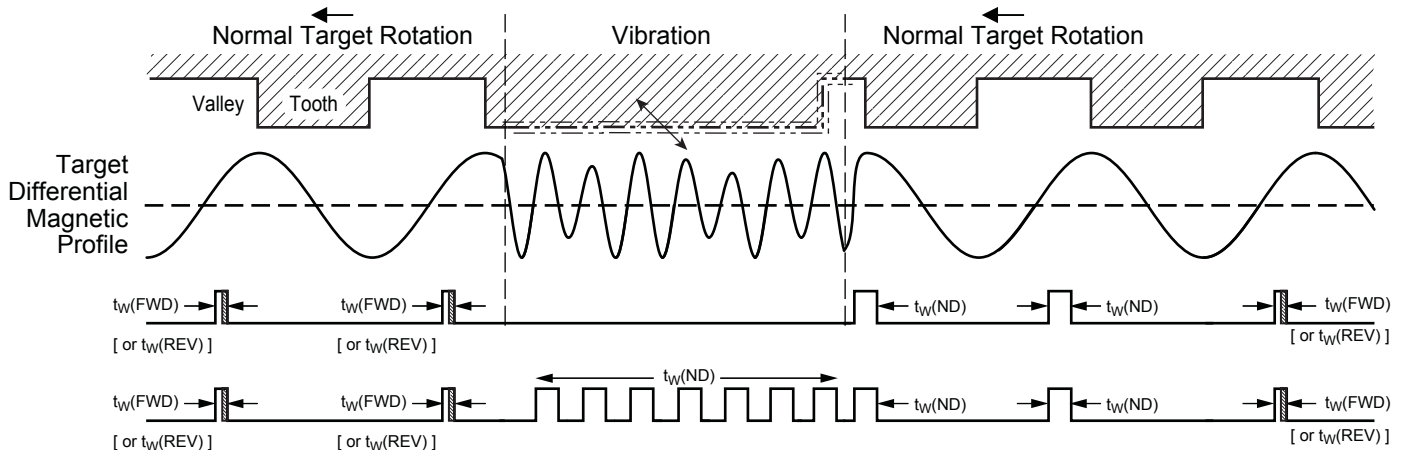

Figure 7. Output functionality in the presence of Running mode target vibration

Application Information

Power Derating

The device must be operated below the maximum junction temperature of the device, $T_{J(max)}$. Under certain combinations of peak conditions, reliable operation may require derating supplied power or improving the heat dissipation properties of the application. This section presents a procedure for correlating factors affecting operating T_J . (Thermal data is also available on the Allegro website.)

The Package Thermal Resistance, $R_{\theta JA}$, is a figure of merit summarizing the ability of the application and the device to dissipate heat from the junction (die), through all paths to the ambient air. Its primary component is the Effective Thermal Conductivity, K , of the printed circuit board, including adjacent devices and traces. Radiation from the die through the device case, $R_{\theta JC}$, is relatively small component of $R_{\theta JA}$. Ambient air temperature, T_A , and air motion are significant external factors, damped by overmolding.

The effect of varying power levels (Power Dissipation, P_D), can be estimated. The following formulas represent the fundamental relationships used to estimate T_J , at P_D .

$$P_D = V_{IN} \times I_{IN} \tag{1}$$

$$\Delta T = P_D \times R_{\theta JA} \tag{2}$$

$$T_J = T_A + \Delta T \tag{3}$$

For example, given common conditions such as: $T_A = 25^\circ C$, $V_{CC} = 12 V$, $I_{CC} = 6.5 mA$, and $R_{\theta JA} = 126^\circ C/W$, then:

$$P_D = V_{CC} \times I_{CC} = 12 V \times 6.5 mA = 78 mW$$

$$\Delta T = P_D \times R_{\theta JA} = 78 mW \times 126^\circ C/W = 9.8^\circ C$$

$$T_J = T_A + \Delta T = 25^\circ C + 9.8^\circ C = 34.8^\circ C$$

A worst-case estimate, $P_D(max)$, represents the maximum allowable power level ($V_{CC(max)}$, $I_{CC(max)}$), without exceeding $T_J(max)$, at a selected $R_{\theta JA}$ and T_A .

Example: Reliability for V_{CC} at $T_A = 150^\circ C$, package SH, using a single-layer PCB.

Observe the worst-case ratings for the device, specifically: $R_{\theta JA} = 126^\circ C/W$, $T_J(max) = 165^\circ C$, $V_{CC(max)} = 24 V$, and $I_{CC(mean)} = 13 mA$. (Note: At maximum target frequency, $I_{CC(LOW)} = 8 mA$, $I_{CC(HIGH)} = 16 mA$, and maximum pulse widths, the result is a duty cycle of 62.4% and a worst case $I_{CC(mean)}$ of 13 mA.)

Calculate the maximum allowable power level, $P_D(max)$. First, invert equation 3:

$$\Delta T_{max} = T_J(max) - T_A = 165^\circ C - 150^\circ C = 15^\circ C$$

This provides the allowable increase to T_J resulting from internal power dissipation. Then, invert equation 2:

$$P_D(max) = \Delta T_{max} \div R_{\theta JA} = 15^\circ C \div 126^\circ C/W = 119 mW$$

Finally, invert equation 1 with respect to voltage:

$$V_{CC(est)} = P_D(max) \div I_{CC(max)} = 119 mW \div 13 mA = 9.2 V$$

The result indicates that, at T_A , the application and device can dissipate adequate amounts of heat at voltages $\leq V_{CC(est)}$.

Compare $V_{CC(est)}$ to $V_{CC(max)}$. If $V_{CC(est)} \leq V_{CC(max)}$, then reliable operation between $V_{CC(est)}$ and $V_{CC(max)}$ requires enhanced $R_{\theta JA}$. If $V_{CC(est)} \geq V_{CC(max)}$, then operation between $V_{CC(est)}$ and $V_{CC(max)}$ is reliable under these conditions.

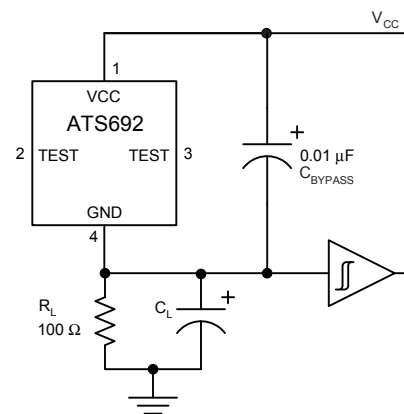
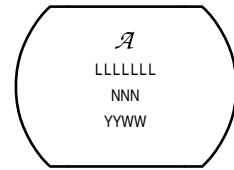
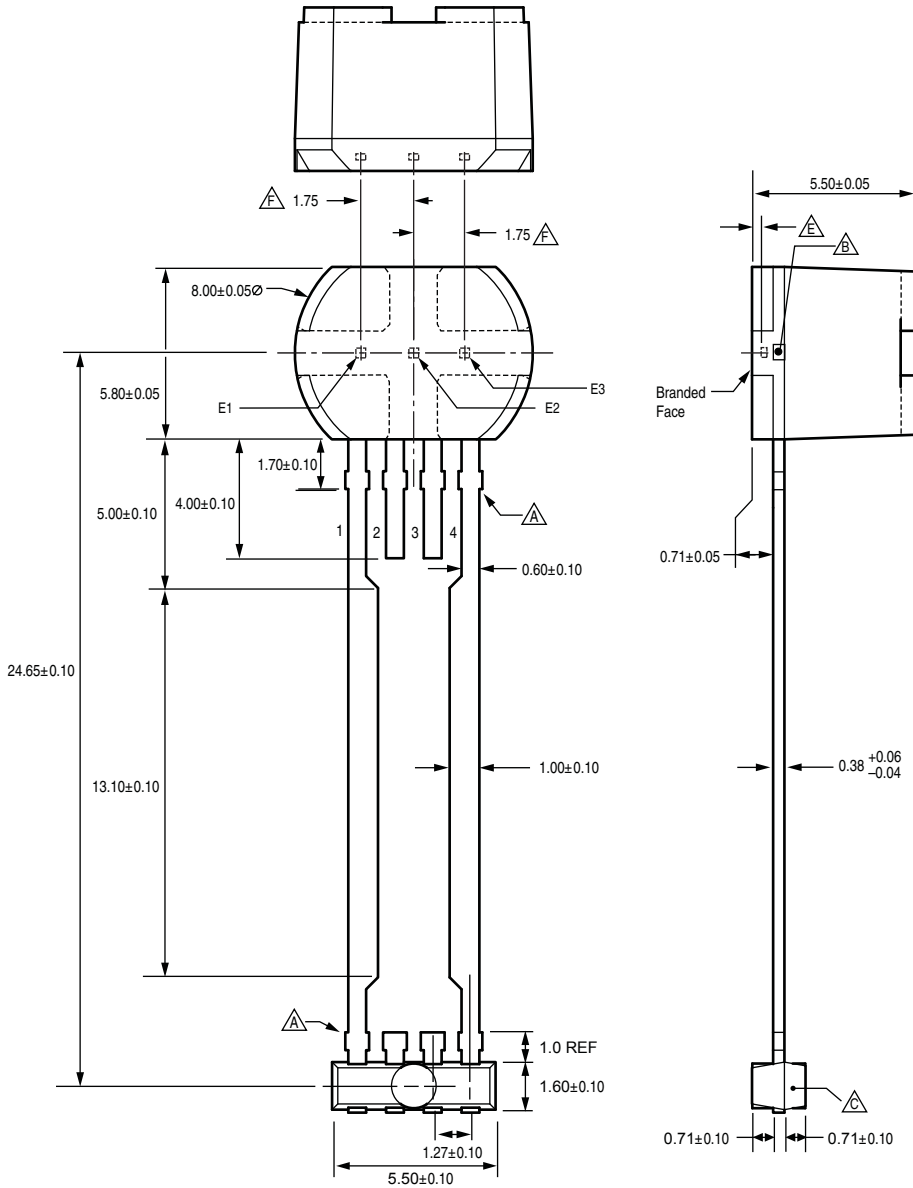

Figure 8. Typical application circuit

Package SH, 4-Pin SIP



Standard Branding Reference View

- A = Supplier emblem
- L = Lot identifier
- N = Last three numbers of device part number
- Y = Last two digits of year of manufacture
- W = Week of manufacture

For Reference Only, not for tooling use (reference DWG-9003)
Dimensions in millimeters

- △ Dambar removal protrusion (16X)
- △ Metallic protrusion, electrically connected to pin 4 and substrate (both sides)
- △ Thermoplastic Molded Lead Bar for alignment during shipment
- △ Branding scale and appearance at supplier discretion
- △ Active Area Depth 0.43 mm REF
- △ Hall elements (E1, E2, E3); not to scale

Revision History

Revision	Revision Date	Description of Revision
Rev. 3	August 27, 2013	Upgrades to select graphics, T _{tsg}

Copyright ©2010-2013, Allegro MicroSystems, LLC

Allegro MicroSystems, LLC reserves the right to make, from time to time, such departures from the detail specifications as may be required to permit improvements in the performance, reliability, or manufacturability of its products. Before placing an order, the user is cautioned to verify that the information being relied upon is current.

Allegro's products are not to be used in life support devices or systems, if a failure of an Allegro product can reasonably be expected to cause the failure of that life support device or system, or to affect the safety or effectiveness of that device or system.

The information included herein is believed to be accurate and reliable. However, Allegro MicroSystems, LLC assumes no responsibility for its use; nor for any infringement of patents or other rights of third parties which may result from its use.

For the latest version of this document, visit our website:

www.allegromicro.com

