



Chipsmall Limited consists of a professional team with an average of over 10 year of expertise in the distribution of electronic components. Based in Hongkong, we have already established firm and mutual-benefit business relationships with customers from,Europe,America and south Asia,supplying obsolete and hard-to-find components to meet their specific needs.

With the principle of “Quality Parts,Customers Priority,Honest Operation,and Considerate Service”,our business mainly focus on the distribution of electronic components. Line cards we deal with include Microchip,ALPS,ROHM,Xilinx,Pulse,ON,Everlight and Freescale. Main products comprise IC,Modules,Potentiometer,IC Socket,Relay,Connector.Our parts cover such applications as commercial,industrial, and automotives areas.

We are looking forward to setting up business relationship with you and hope to provide you with the best service and solution. Let us make a better world for our industry!



Contact us

Tel: +86-755-8981 8866 Fax: +86-755-8427 6832

Email & Skype: info@chipsmall.com Web: www.chipsmall.com

Address: A1208, Overseas Decoration Building, #122 Zhenhua RD., Futian, Shenzhen, China





Introduction

The ATSAM4C-EK is an evaluation kit for the 32-bit ARM® Cortex®-M4 SAM4C microcontroller from Atmel® Corporation.

The ATSAM4C-EK can be used with the following SAM4C series microcontrollers:

- SAM4C16C
- SAM4C8C

This document describes the kit contents and architecture, and provides guidelines on how to use the kit.

Contents

- Board
 - One SAM4C Evaluation Kit Board (EK)
- Power Supply
 - One universal input AC/DC power supply with US, Europe and UK plug adapters
 - One 3V Lithium Battery type CR1225
- Cables
 - One serial RS232 cable
 - One micro A/B-type USB cable
- Welcome letter

Reference documents

- Atmel SAM4C Series Datasheet
(http://www.atmel.com/images/atmel_11102_smartenergy_sam4c16-c8_datasheet.pdf)

Table of Contents

Introduction	1
Contents	2
Reference documents.	2
Table of Contents	3
1. Evaluation Kit Specifications	4
1.1 Electrostatic Warning	4
1.2 Battery.	4
1.3 Recovery Procedure	4
2. Power Up	5
2.1 Power up the Board	5
2.2 Sample Code and Technical Support	5
3. Evaluation Kit Hardware	6
3.1 Overview	6
3.2 Equipment List	7
3.3 Function Blocks.	9
3.4 Embedded Memories	12
3.5 Communication Interfaces	14
3.6 Debug Interfaces.	15
3.7 Extend Interfaces	16
3.8 LCD Display	18
3.9 Analog I/O	21
3.10 CryptoAuthentication (optional).	22
3.11 LEDs and Buttons	23
3.12 Miscellaneous I/O	24
3.13 Metrology Core Serial Interface	24
3.14 PIO Usage	25
3.15 Connectors	28
4. Evaluation Kit Firmware Demonstration	35
4.1 ATSAM4C-EK Default Application	35
4.2 Measuring the Backup mode current consumption on VDDBU	35
5. ATSAM4C-EK Design Files	37
5.1 ATSAM4C-EK Schematics	37
5.2 ATSAM4C-EK Layout	45
6. Revision History	53

1. Evaluation Kit Specifications

Table 1-1. Evaluation Kit Specifications

Characteristic	Specifications
PCB	6 layers, 140 mm x 100 mm
PCB Material	Standard FR4 in 1.6 mm thickness
Clock Speed	Crystal 8 MHz Piezoelectric Ceramic Resonator 8.192 MHz 32.768 kHz external clock
Ports	RS232 RS485 USB
Memory	TWI EEPROM Serial Data Flash
Board Supply Voltage	5V DC from main connector power supply 5V DC from USB 3V Battery for Backup and RTC
ROHS	Compliant
CE and FCC Part 15 status	Compliant

1.1 Electrostatic Warning

Warning: ESD-Sensitive Electronic Equipment!



The evaluation kit is shipped in a protective anti-static package. The board system must not be subjected to high electrostatic discharge.

We strongly recommend using a grounding strap or similar ESD protective device when handling the board in hostile ESD environments (offices with synthetic carpet, for example). Avoid touching the component pins or any other metallic element on the board.

1.2 Battery

The ATSAM4C-EK ships with a 3V coin battery. This battery is not required for the board to start up as long as Jumper JP8 is closed.

The coin battery is provided for user convenience in case the user would like to exercise the date and time backup function of the SAM4C devices when the board is switched off.

1.3 Recovery Procedure

The demo software is stored in internal Flash memory. If the content of the internal Flash has been erased, it can be reprogrammed recovered to the state as it was when shipped by Atmel using Atmel SAM-BA[®] In-system Programmer available on the Atmel website (www.atmel.com/tools/atmelsam-bain-systemprogrammer.aspx). The binary file of the demo software is available on the Atmel website in the ATSAM4C-EK Evaluation Kit Section (<http://www.atmel.com/tools/SAM4C-EK.aspx>).

2. Power Up

2.1 Power up the Board

Unpack the board taking care to avoid electrostatic discharge. Unpack the power supply, select the right power plug adapter corresponding to that of your country, and insert it in the power supply.

Connect the power supply DC connector to the board and plug the power supply to an AC power plug. The board LCD should light up and display a graphic demo program.

2.2 Sample Code and Technical Support

After boot up, designers can run sample code or their own application, on the development kit. Users can download sample code and get technical support from the Atmel website. The ATSAM4C-EK is supported by the Atmel Software Framework (ASF) (<http://www.atmel.com/tools/AVRSOFTWAREFRAMEWORK.aspx>).

3. Evaluation Kit Hardware

3.1 Overview

This section introduces the Atmel SAM4C Evaluation Kit design. It introduces system-level concepts, such as power distribution, memory, and interface assignments.

The Atmel SAM4C16C and SAM4C8C microcontrollers are system-on-chip solutions for smart energy applications, built around two high-performance 32-bit ARM Cortex-M4 RISC processors. These devices operate at a maximum speed of 120 MHz and feature up to 1 Mbyte of embedded Flash, 152 Kbytes of SRAM and on-chip cache for each core.

The dual ARM Cortex-M4 architecture allows for integration of application layer, communications layers and security functions in a single device, with the ability to extend program and data memory via a 16-bit external bus interface. The peripheral set includes an advanced cryptographic engine, two anti-tamper pins with time-stamping function, floating point unit (FPU), five USARTs, two UARTs, two TWIs, up to seven SPIs, as well as a PWM timer, two 3-channel general-purpose 16-bit timers, temperature compensable low-power RTC running on backup area down to 0.5 μ A, and a 50 x 6 segmented LCD controller.

The SAM4C series is a scalable platform providing, alongside Atmel's industry leading SAM4 standard microcontrollers, unprecedented cost structure, performance and flexibility to smart meter designers worldwide.

Figure 3-1. ATSAM4C-EK Board Architecture

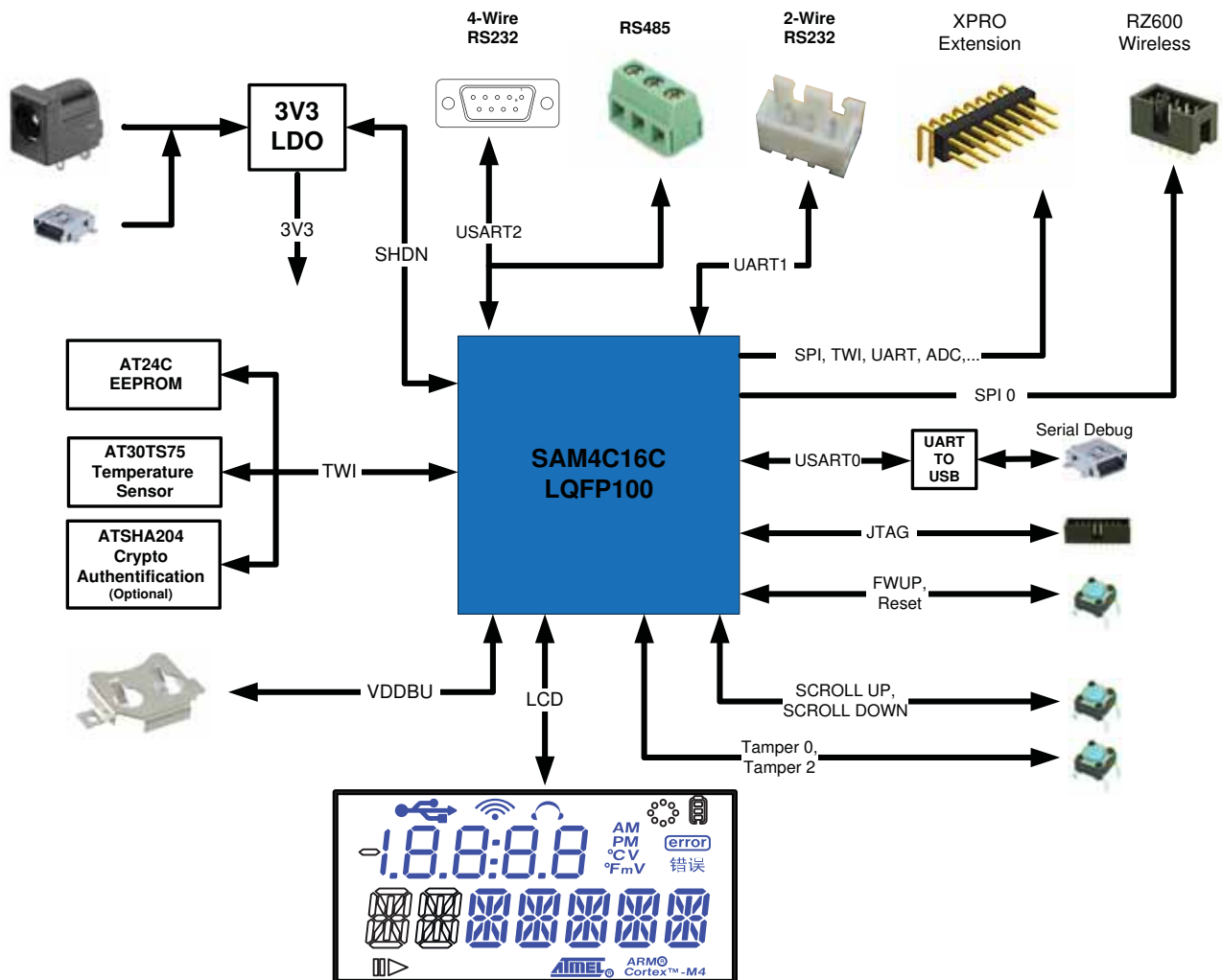

3.2 Equipment List

3.2.1 Features List

The CM board components are listed as follows:

- CPU SAM4C with its embedded resources
 - 8 MHz and 32.768 kHz Quartz Crystal, SMB connector for external source
 - Main regulator 5V/3.3V with red LED indicator
 - 1 Lithium Coin Cell Battery
- Main board with:
 - 1 custom segmented LCD
 - 1 shared interface RS232 / RS485
 - 1 Serial data Flash SPI
 - 1 Two-Wire Serial EEPROM
 - 1 Two-Wire Temperature Sensor
 - 1 Two-Wire CryptoAuthentication™ Memory (*optional*)
- Debug solution:
 - 2 peripheral Input/Output extension connectors HE10 (PIO A, B)
 - 1 peripheral Input/Output extension connector HE10 (PIO Sense)
 - 1 JTAG/ICE interface
 - 1 UART/USB bridge Device Communication interface
- Analog
 - 1 Analog 3V reference
 - 1 Potentiometer connected on ADC input
- Buttons
 - 4 system push buttons: Reset, Force Wake-Up, Tamper 0, Tamper 2
 - 2 user push buttons: Scroll Up and Scroll Down
- LEDs
 - 1 amber LED
 - 1 blue LED
 - 1 green LED

3.2.2 Interface Connection

The ATSAM4C-EK board includes hardware interfaces such as:

- 1 RS232/RS485 (USART0 RX, TX, RTS, CTS) connected to:
 - 9-way male D-type RS232 connector
 - 3-pin connector
- 1 JTAG/SWD 20-pin IDC connector
- 1 USB 5-pin type Micro AB connector (bridge UART)
- 3 PIOs connected to HE10 connectors

Figure 3-2. Annotated ATSAM4C-EK Board Layout

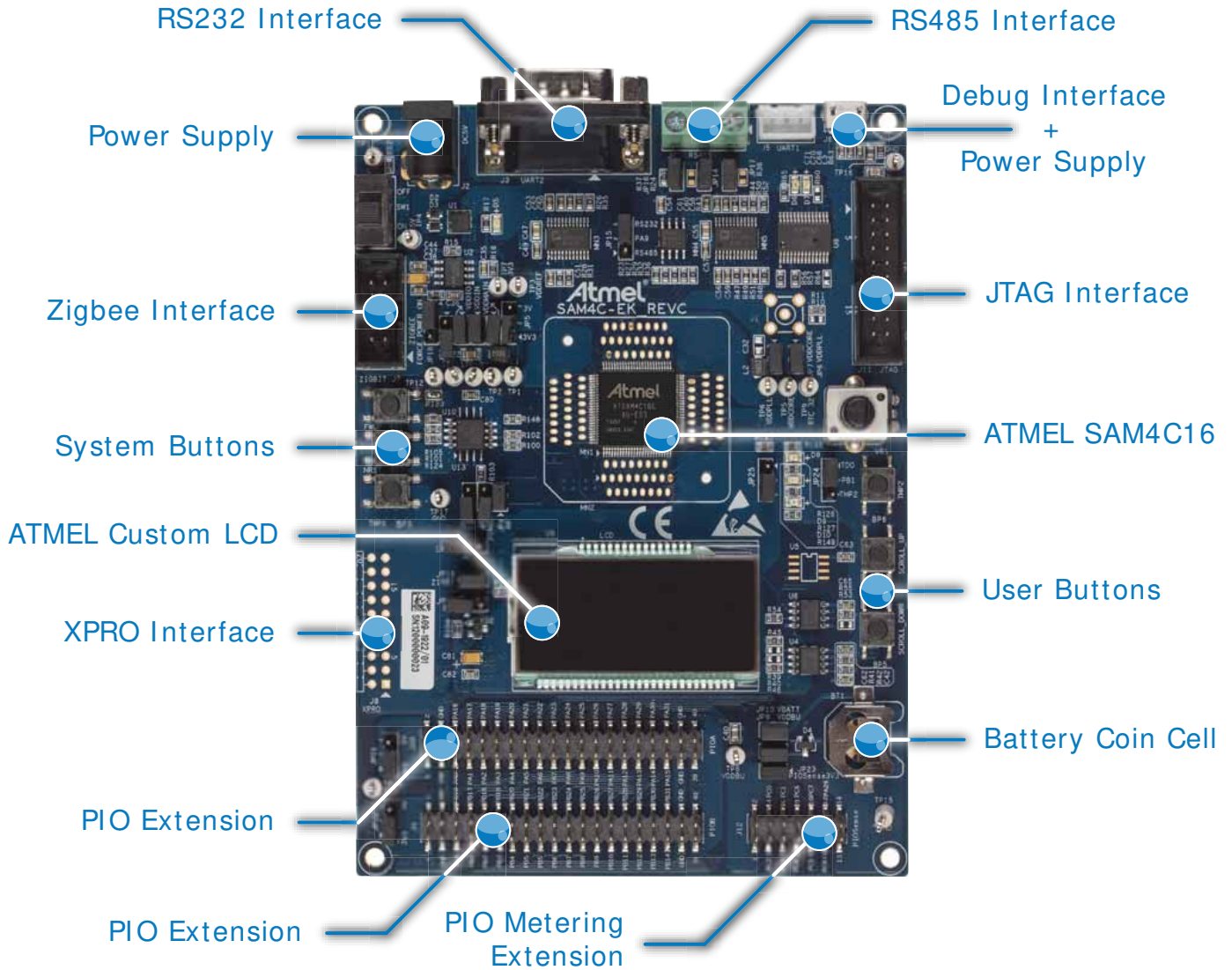

3.3 Function Blocks

3.3.1 Processor

The ATSAM4C-EK board is equipped with a SAM4C16 device in an LQFP100 package.

Figure 3-3. SAM4C Processor

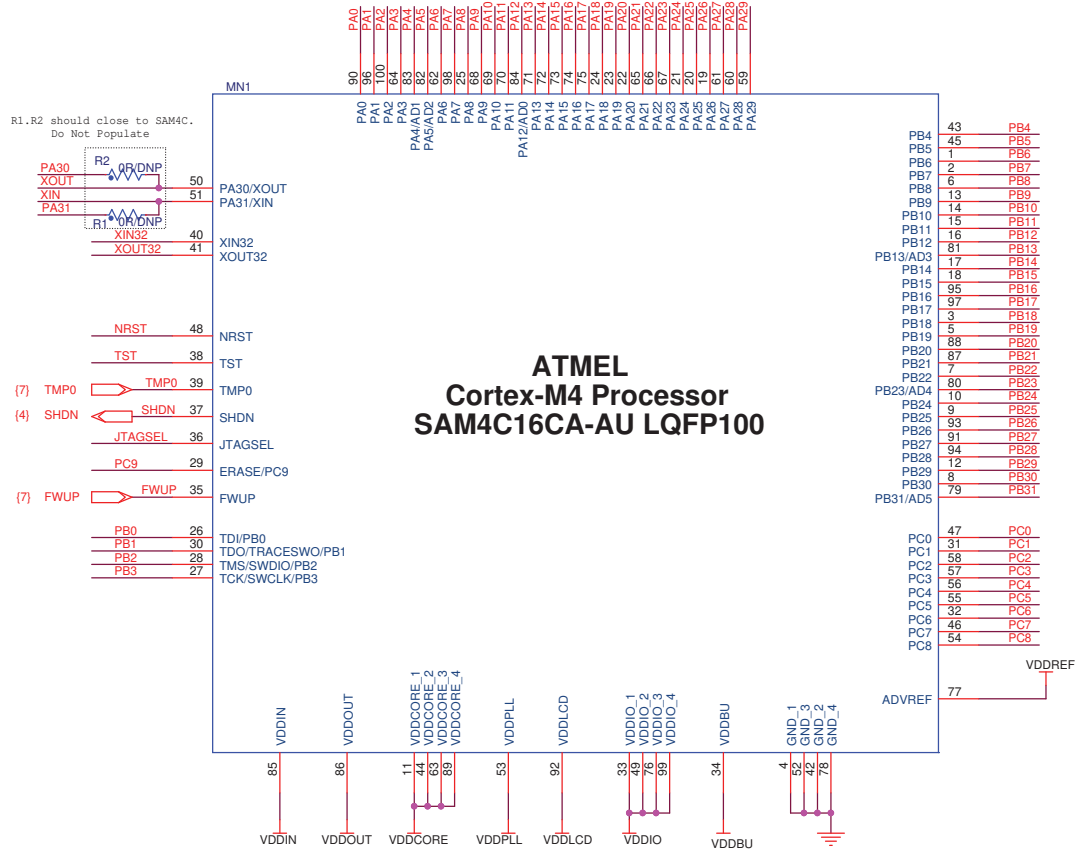

3.3.2 Clock Distribution

The ATSAM4C-EK board includes two clock systems (see Table 3-1 and Figure 3-4).

Table 3-1. Components Clock System

Qty	Description	Component Assignment
1	Crystal for Internal Clock 8 MHz	Y2
1	Crystal for RTC Clock 32.768 kHz	Y1

Figure 3-4. Clock System

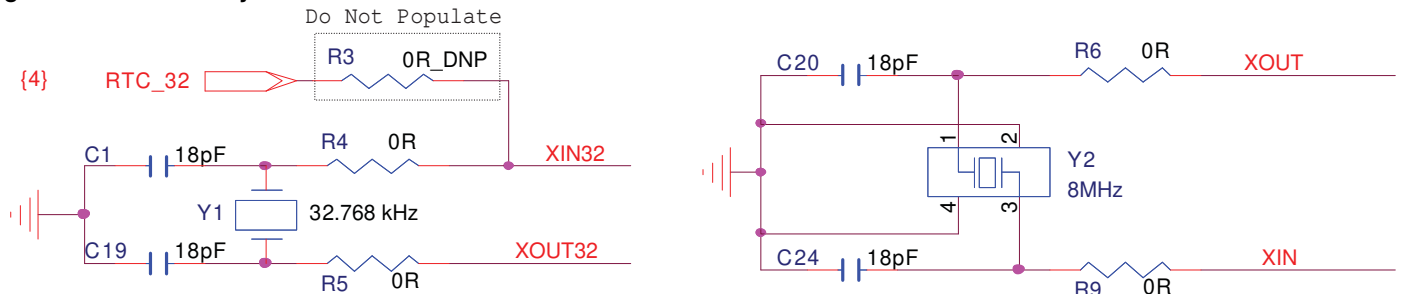

3.3.3 Reset and Wake-Up Circuitry

The reset sources for the EK board are:

- Power on reset
- Push button reset (refer to [Section 3.11.2 “Push Buttons”](#))
- JTAG reset from an in-circuit emulator

3.3.4 Power Supplies

The ATSAM4C-EK board evaluation and development platform embeds all the necessary power rails required for the SAM4C processor and peripherals.

The ATSAM4C-EK board can be supplied by either a 5V DC block through input J2 (see [Figure 3-5](#)) or a USB connection via J6 (refer to [“DBGU/USB Bridge Schematic” on page 16](#)).

A manual power supply selection switch (SW1) is provided to power on/off the main power line.

Figure 3-5. Power Supply Schematic

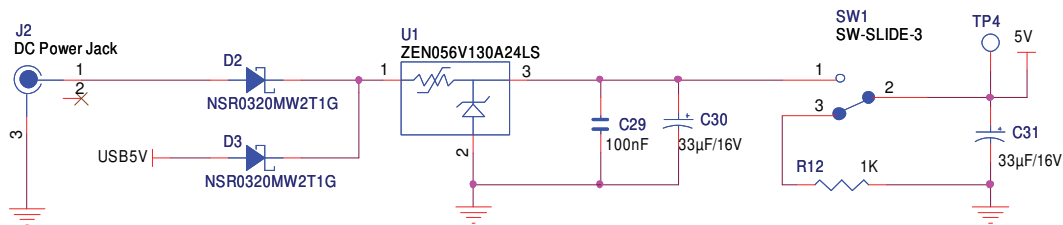

3.3.5 Power Rails

The SAM4C supports 1.6V–3.6V single supply mode (VDDIN). An internal regulator input is connected to the source and its output feeds VDDCORE (VDDOUT connected to VDDCORE).

When the 3.3V supply is present, the Power LED D5 is lit. Test points TP2 to TP5 are used to perform testing.

Table 3-2. Power Supply Voltage Ranges

Power Supply	Ranges	Comments
VDDIO	1.6V–3.6V	Flash Memory Charge Pumps Supply for Erase and Program Operations, and Read operation Input Output buffers Supply
VDDBU	1.6V–3.6V	Backup Area power supply. VDDBU is automatically disconnected when VDDIO is present (> 1.9V)
VDDIN	1.6V–3.6V	1.6V min. if LCD and ADC not used, 2.5V otherwise
VDDLCD	2.5V–3.6V	LCD Voltage Regulator Output External LCD power supply input (LCD regulator not used) VDDIO/VDDIN need to be supplied when the LCD Controller is used
VDDOUT	1.2V Output	120 mA Output Current
VDDPLL	1.08V–1.32V	–
VDDCORE	1.08V–1.32V	–

3.4 Embedded Memories

- I2C for data storage in EEPROM (Atmel AT24C1024B)
- SPI Serial Flash AT45 or AT25F

3.4.1 TWI EEPROM

The AT24C1024B provides 1,048,576 bits of serial electrically erasable and programmable read-only memory (EEPROM) organized as 131,072 words of 8 bits each.

Device slave address byte: 0x50.

Figure 3-8. TWI EEPROM Schematic

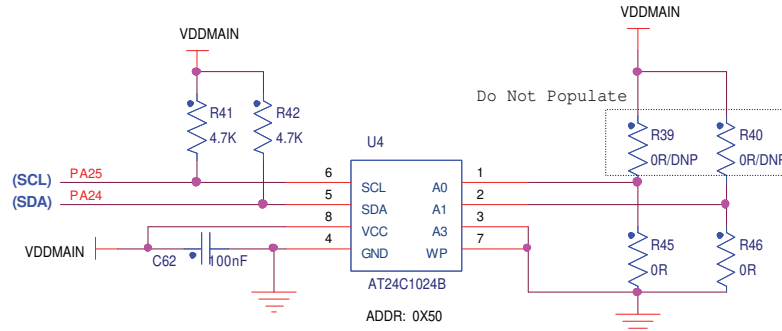

3.4.2 SPI Serial Flash

The ATSAM4C-EK embeds one serial Flash device AT25DFxx or AT45DBxx connected through the SPI. (The AT25DF321A is mounted by default.)

Figure 3-9. SPI Serial Flash Schematic

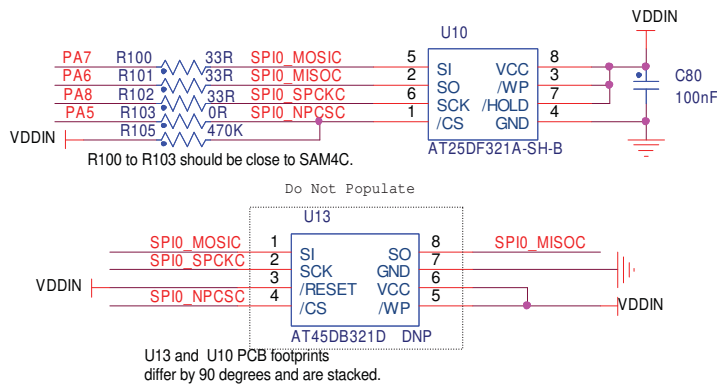

3.4.3 Compatible Devices

Table 3-3. Compatible Devices

Adesto AT45DB Series Devices	Adesto AT25DF Series Devices
AT45DB64D2-CNU	AT25DF641A-SH
AT45DB321D-MWU	AT25DF321A-SH
AT45DB131D-SS	AT25DF161-SH
AT45DB081D-SS	AT25DF081-SSH
AT45DB041D-SS	AT25DF021-SH
AT45DB021D-SS	—
AT45DB011D-SS	—

3.5 Communication Interfaces

3.5.1 Serial Port USART2 RS232

The USART2 is buffered with one RS-232 Transceiver ADM3312E (Analog Devices) and is connected to a DB9 connector. A classic implementation RS232 transceiver selection should include double source capability. The USART2 connector with RTS/CTS handshake signal support is connected to the RS232 transceiver.

Features:

- One RS232 transceiver connected to RXD2, TXD2, RTS2, and CTS2
- One DB9 male connector
- Required resistors and capacitors

Figure 3-10. USART2 RS232 Schematic

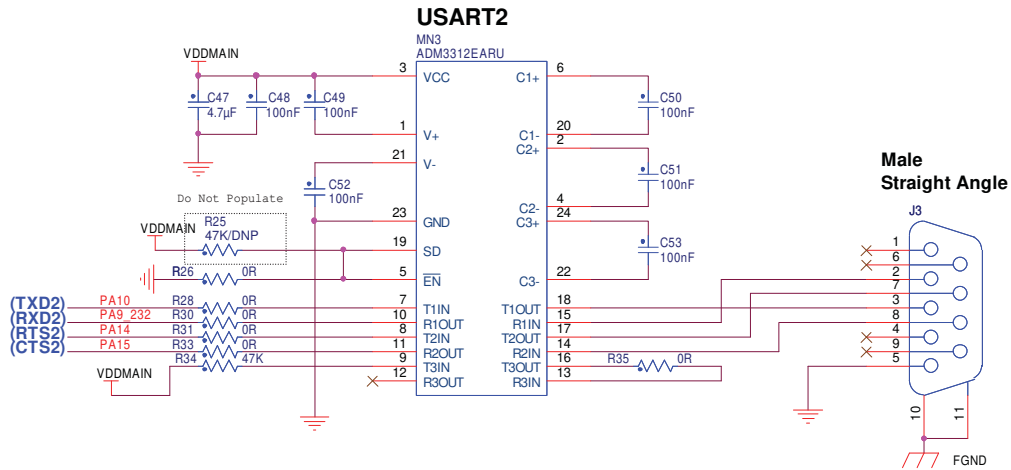

3.5.2 Serial Port USART2 RS485

The USART2 is buffered with an Analog Devices ADM3485 RS-485/RS-422 transceiver and is connected to a 3-point jumper.

Features:

- One RS485 transceiver connected to RXD2, TXD2 and RTS2, CTS2
- One 3-point connector
- Required resistors and capacitors

Figure 3-11. USART2 RS485 Schematic

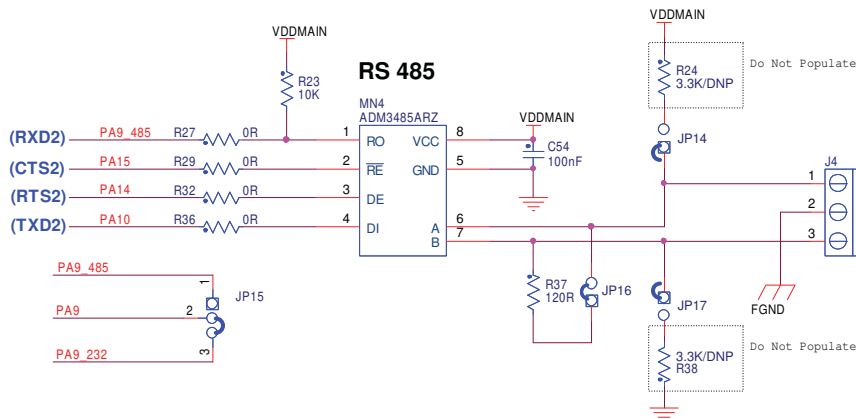

3.5.3 Serial Port UART1 RS232

The UART1 is buffered with an Analog Devices ADM3312E RS-232 transceiver and is connected to the HE10 PIO port C. A classic implementation RS232 transceiver selection should include double source capability.

Features:

- One RS232 transceiver connected to RXD (PC1) and TXD (PC0) only
- One HE10 male connector (PIO port C)
- Required resistors and capacitors

Figure 3-12. Serial Port Schematic

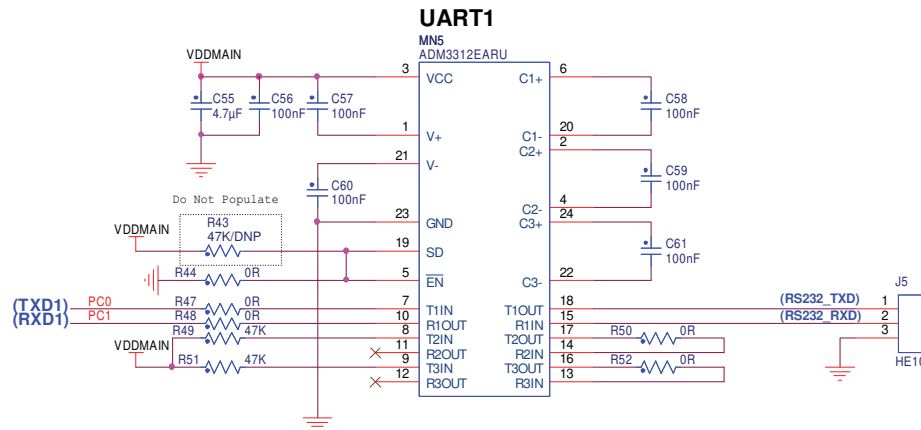

3.6 Debug Interfaces

3.6.1 JTAG/ICE

The ATSAM4C-EK includes a JTAG interface port to provide debug level access to the system-on-chip. The JTAG port is a 20-pin, dual-row, 0.1-inch male connector. This port provides the required interface for in-circuit emulators such as the ARM Multi-ICE[®] and Atmel SAM-ICE[™].

Features:

- One HE10 20-pin male connector
- Required resistors

Figure 3-13. JTAG/ICE Interface Schematic

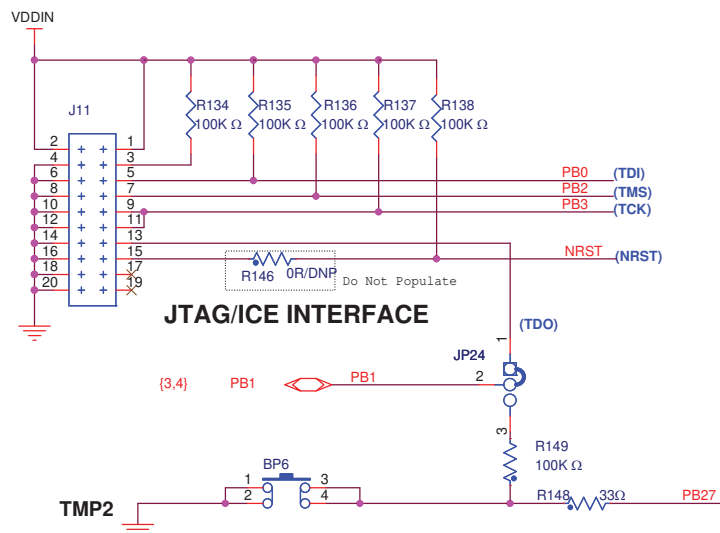

3.6.2 UART/USB Bridge Interface

The UART is connected to an interface USB through an FTDI FT232R (TTL to USB converter) device. RX and TX DBGU only are connected to the USB connector Micro AB.

Figure 3-14. DBGU/USB Bridge Schematic

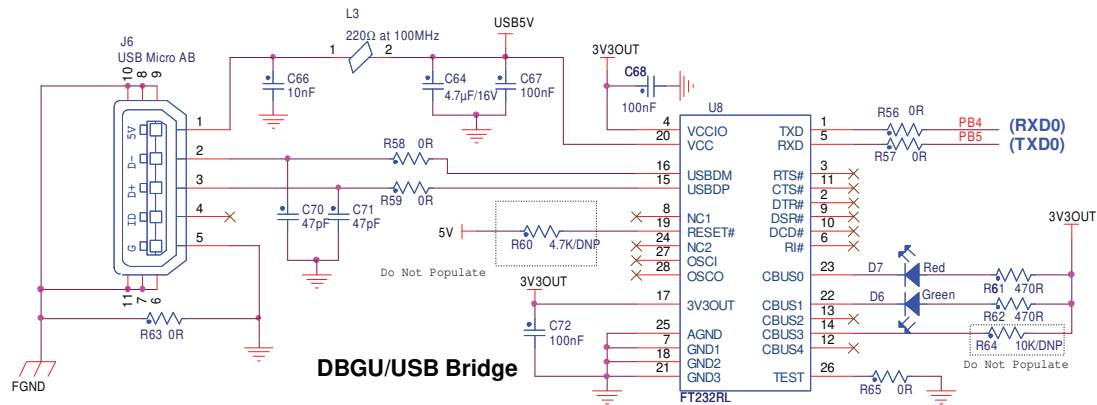

3.7 Extend Interfaces

The SAMAC-EK embeds two connectors to interface Atmel IEEE 802.15.4-compliant wireless transceivers for ZigBee®-based applications.

Features:

- Atmel RZ600 module
- Atmel REB233-XPRO module

3.7.1 RZ600 Interface

- The RZ600 interface connects with Atmel modules used for ZigBee communication platforms that are equipped with a 10-pin HE10 male connector.

Figure 3-15. RZ600 Interface Schematic

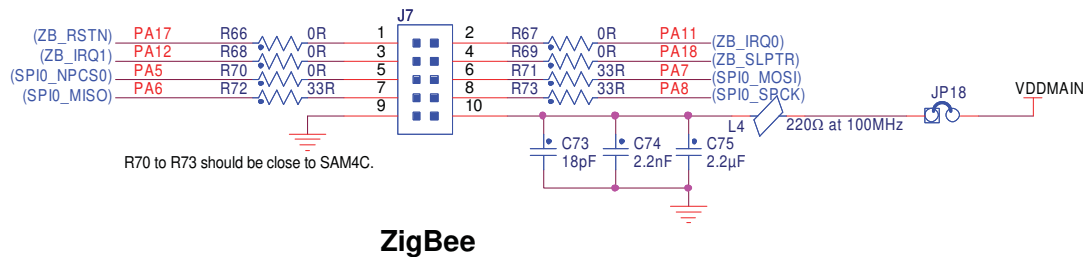

Table 3-4. RZ600 HE10 Pin Functions

Function	Pin	Pin	Function
Reset	1	2	IRQ0
Interrupt Request	3	4	SLP_TR
SPI Chip Select	5	6	SPI MOSI
SPI MISO	7	8	SPI CLK
Power Ground	9	10	Power Supply

3.7.2 REB233-XPRO Interface

The XPRO interface connects with new Atmel modules used for XPRO platforms that are equipped with a 20-pin HE14 male connector.

Figure 3-16. XPRO Interface Schematic

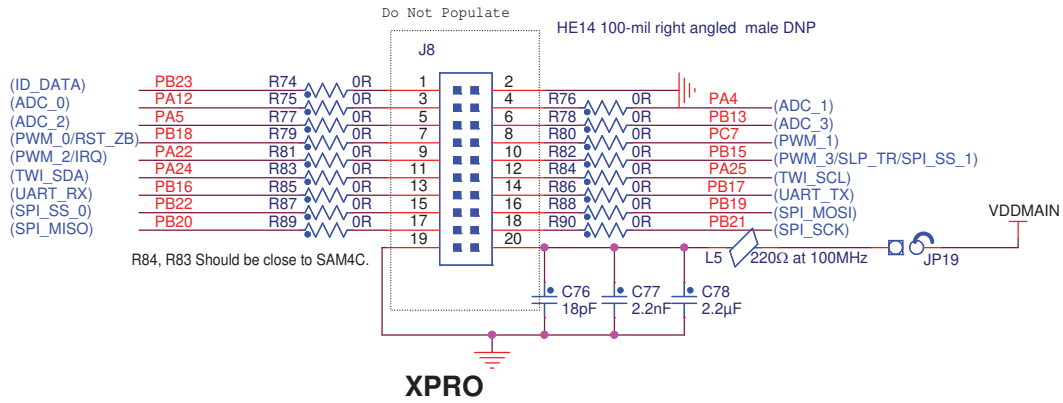

Table 3-5. XPRO HE10 Pin Functions

Function	Pin	Pin	Function
Module Identity	1	2	Ground
ADC Input	3	4	ADC Input
ADC Input	5	6	ADC Input
ZigBit™ Reset	7	8	PWM Output
IRQ Interrupt from ZigBit to Host Processor	9	10	SLP_TR wake-up signal to ZigBit
Two-Wire Data Line	11	12	Two-Wire Clock Line
UART RX Line	13	14	UART TX Line
SPI Chip Select	15	16	SPI MOSI
SPI MISO	17	18	SPI Clock
Power Ground	19	20	Power Supply

3.8 LCD Display

The ATSAM4C-EK board is equipped with one LCD segment interfaced with the SAM4C device through the LCD controller. Note that only certain segments (highlighted in blue in Figure 3-17 on page 18) are usable without using U11 and U12 analog switches or unpopulated 0 ohm resistors.

Features:

- LCD segment YMCC42364AAANDCL (Anshan Yes Optoelectronics Display Co., Ltd.)

Figure 3-17. LCD Display Schematic

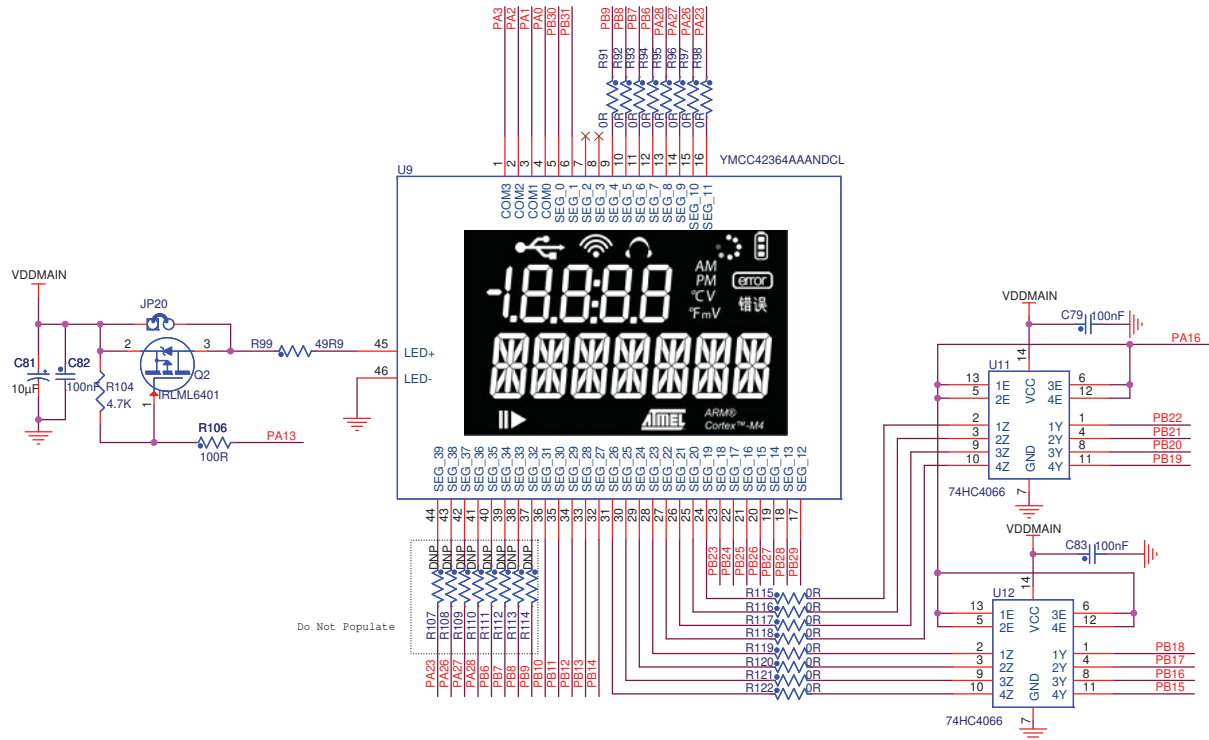

Figure 3-18. LCD Layout

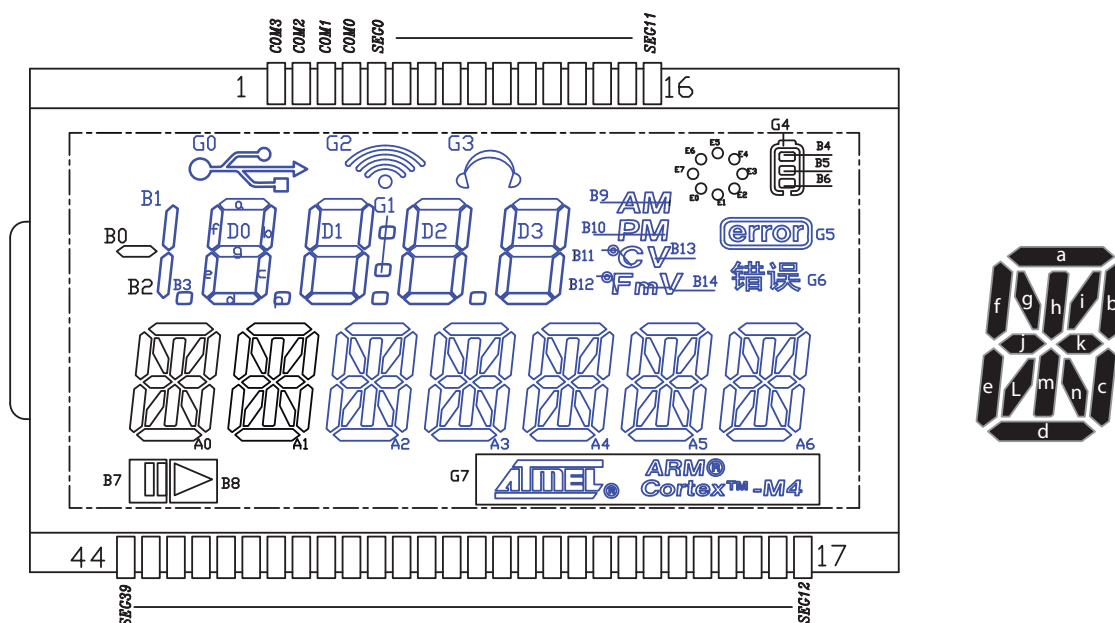

Table 3-6. LCD pinout vs Segment

Pin	COM0	COM1	COM2	COM3
1	–	–	–	COM3
2	–	–	COM2	–
3	–	COM1	–	–
4	COM0	–	–	–
5	G1	G0	G2	G3
6	G4	G5	G6	G7
7	E0	E2	E4	E6
8	E1	E3	E5	E7
9	D3-a	D3-b	D3-c	B9
10	D3-f	D3-g	D3-e	D3-d
11	D2-a	D2-b	D2-c	D2-p
12	D2-f	D2-g	D2-e	D2-d
13	D1-a	D1-b	D1-c	D1-p
14	D1-f	D1-g	D1-e	D1-d
15	D0-a	D0-b	D0-c	D0-p
16	D0-f	D0-g	D0-e	D0-d
17	A6-h	A6-i	A6-k	A6-n
18	B14	A6-f	A6-e	A6-d
19	A6-a	A6-b	A6-c	B13
20	A6-g	A6-j	A6-L	A6-m
21	A5-h	A5-i	A5-k	A5-n
22	B5	A5-f	A5-e	A5-d

Pin	COM0	COM1	COM2	COM3
23	A5-a	A5-b	A5-c	B12
24	A5-g	A5-j	A5-L	A5-m
25	A4-h	A4-i	A4-k	A4-n
26	B6	A4-f	A5-e	A5-d
27	A4-a	A4-b	A4-c	B11
28	A4-g	A4-j	A4-L	A4-m
29	A3-h	A3-i	A3-k	A3-n
30	B4	A3-f	A3-e	A3-d
31	A3-a	A3-b	A3-c	B10
32	A3-g	A3-j	A3-L	A3-m
33	A2-h	A2-i	A2-k	A2-n
34	B3	A2-f	A2-e	A2-d
35	A2-a	A2-b	A2-c	B1
36	A2-g	A2-j	A2-L	A2-m
37	A1-h	A1-i	A1-k	A1-n
38	B2	A1-f	A1-e	A1-d
39	A1-a	A1-b	A1-c	B8
40	A1-g	A1-j	A1-L	A1-m
41	A0-h	A0-i	A0-k	A0-n
42	B0	A0-f	A0-e	A0-d
43	A0-a	A0-b	A0-c	B7
44	A0-g	A0-j	A0-L	A0-m

Table 3-7. LCD PIO Mapping

Pin Name	LCD Pin	PIO	PIO	LCD Pin	Pin Name
COM0	4	PA0	PA1	3	COM1
COM2	2	PA2	PA3	1	COM3
SEG0	5	PB30	PB31	6	SEG1
SEG2	7	Not used	Not used	8	SEG3
SEG4	9	PB9	PB8	10	SEG5
SEG6	11	PB7	PB6	12	SEG7
SEG8	13	PA28	PA27	14	SEG9
SEG10	15	PA26	PA23	16	SEG11
SEG12	17	PB29	PB28	18	SEG13
SEG14	19	PB27	PB26	20	SEG15
SEG16	21	PB25	PB24	22	SEG17
SEG18	23	PB23	PB22	24	SEG19
SEG20	25	PB21	PB20	26	SEG21
SEG22	27	PB19	PB18	28	SEG23
SEG24	29	PB17	PB16	30	SEG25
SEG26	31	PB15	PB14	32	SEG27
SEG28	33	PB13	PB12	34	SEG29
SEG30	35	PB11	PB10	36	SEG31
SEG32	37	PB9	PB8	38	SEG33
SEG34	39	PB7	PB6	40	SEG35
SEG36	41	PA28	PA27	42	SEG37
SEG38	43	PA26	PA23	44	SEG39

3.9 Analog I/O

3.9.1 Analog Reference

The SAM4C features a LM4040 precision micropower curvature-corrected bandgap shunt voltage reference with a several fixed reverse breakdown voltages. The device voltage reference on the board is 3.0V.

Figure 3-19. Analog Reference Schematic

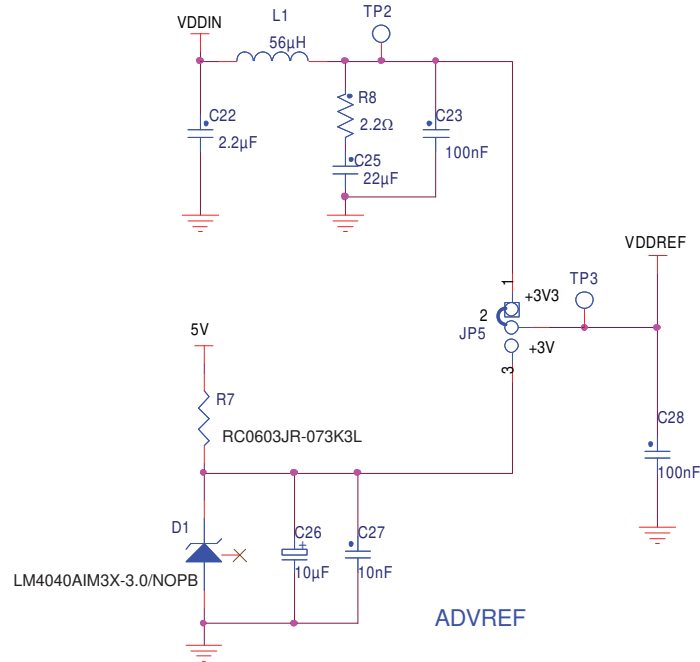

3.9.2 Analog Input

One potentiometer VR1 multi-turn 10K Ω is connected to the jumper JP4. If JP4 is closed, this analog reference is available on analog input PA4.

Figure 3-20. Analog Input Schematic

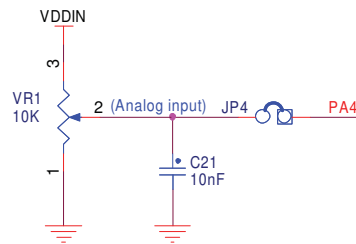

3.9.3 Temperature Sensor

The Atmel AT30TS75 temperature sensor converts temperatures from -40°C to +125°C to a digital word and provides a typical accuracy of $\pm 0.5^\circ\text{C}$ over the operating temperature range of 0°C to +85°C. The device is factory calibrated and requires no external components to help provide a cost effective solution. To reduce current consumption and save power, the AT30TS75 features a shutdown mode that turns off all internal circuitry except for the internal power-on reset and serial interface circuits. In addition, the device features a power saving one-shot mode that allows the device to make a temperature measurement and update the temperature register and then return to shutdown mode.

Device slave address byte: 0x48.

Figure 3-21. Temperature Sensor Schematic

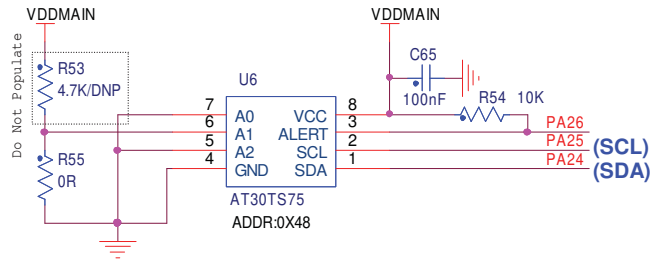

3.10 CryptoAuthentication (optional)

The Atmel ATSHA204 is a member of the Atmel CryptoAuthentication family of high-security hardware authentication devices.

It has a flexible command set that allows use for many applications, such as Anti-counterfeiting, Protection for Firmware or Media, Session Key Exchange, Secure Data Storage or User Password Checking.

Device slave address byte: 0xC9.

Figure 3-22. CryptoAuthentication Schematic

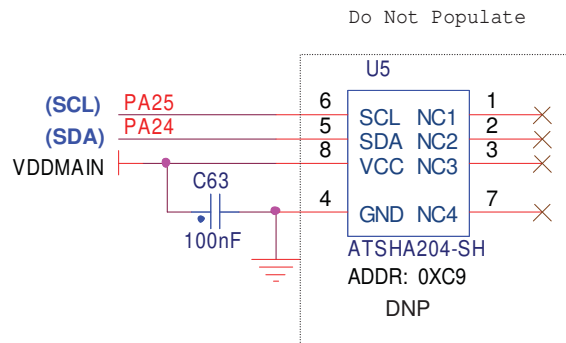

3.11 LEDs and Buttons

The ATSAM4C-EK is equipped with two user push buttons and three LEDs.

3.11.1 Discrete LEDs

Indicators on the main board include three discrete LEDs:

- 1 blue LED connected to a PIO
- 1 amber LED connected to a PWM output
- 1 green LED connected to a PWM output

Figure 3-23. Debug Discrete LED Schematic

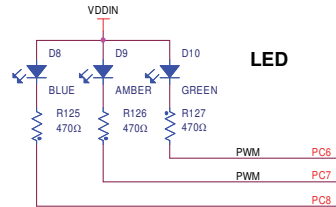

3.11.2 Push Buttons

The EK board is equipped with four system push buttons and two user push buttons. The push buttons consist of momentary push button switches mounted directly to the board. When any switch is depressed it will cause a low (zero) to appear at the associated input pin.

- System push buttons:
 - NRST (Reset, perform system reset)
 - FWUP (Force Wake-Up)
 - TMP0 (Tamper)
 - TMP2 (Tamper)
- User push buttons:
 - SCROLL_UP
 - SCROLL_DOWN

Figure 3-24. Push Buttons Schematic

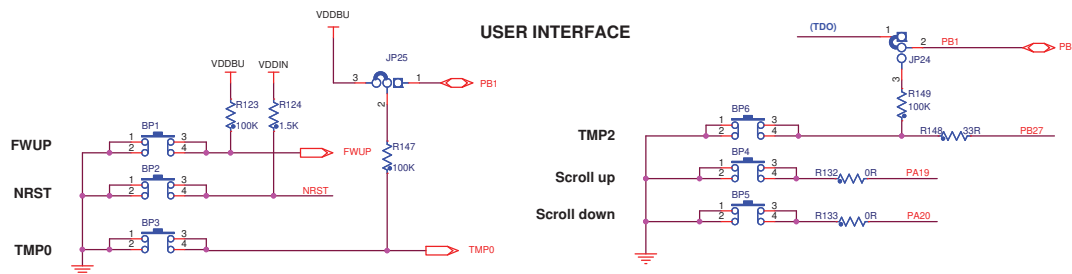

It is possible to select the pull-up level for Tamper TMP0 pin. By selecting PB1 instead of VDDBU, it allows to end user a dynamic tampering synchronized with RTCOUT pin. It allows a diminution of the power consumption when the button is pressed (divided by the Duty Cycle applied on RTCOUT Output signal).

It is possible to use the TMP2 Push Button as another Tamper input. By using this feature, the end user must use JTAG in 2-wire mode (SWIO and SWD) due to the loss of the TDO pin. In this case TMP2 is pull-up at RTCOUT Level (PB1 pin) and can be managed dynamically synchronized with the RTCOUT pin.

3.12 Miscellaneous I/O

This board is equipped with additional I/O connectors which allow the measurements of specific points are allow the connection of an additional extension board.

Figure 3-25. PIO A and PIO B Extension I/O Connectors Schematic

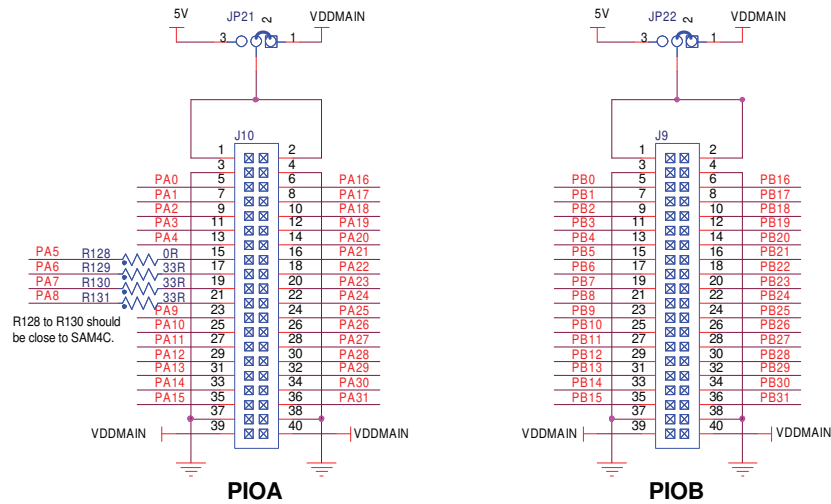

3.13 Metrology Core Serial Interface

This board includes an additional connector which allows connecting to an external board through the SPI 1 port.

Figure 3-26. Connector Schematic

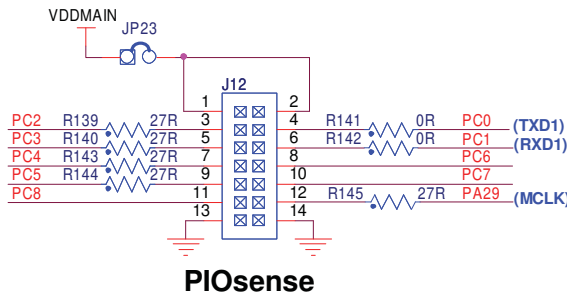

3.14 PIO Usage

3.14.1 PIO Port A Pin Assignments

Table 3-8. PIO Port A Pin Assignments

I/O Line	Peripheral			Extra Function	System Function	Reset State	Using
	A	B	C				
PA0	RTS3	PCK2	A10	COM0	WKUP5	PIO, I, PU, ST	LCD Com
PA1	CTS3	NCS1	A9	COM1	–		LCD Com
PA2	SCK3	NCS2	A8	COM2	–		LCD Com
PA3	RXD3	NCS3	A7	COM3	WKUP6		LCD Com
PA4	TXD3	–	A6	COM4/AD1	–		Analog input
PA5	SPI0_NPCS0	–	A5	COM5/AD2	–		SerFlash / NPCS
PA6	SPI0_MISO	–	A4	SEG0	–		ZigBee
PA7	SPI0_MOSI	–	A3	SEG1	–		ZigBee
PA8	SPI0_SPCK	–	A2	SEG2	–		ZigBee
PA9	RXD2	–	A1	SEG3	WKUP2		RS232/485
PA10	TXD2	–	A0/NBS0	SEG4	–		RS232/485
PA11	RXD1	–	A23	SEG5	WKUP9		ZigBee / IRQ0
PA12	TXD1	–	A22-NCLE	SEG6/AD0	–		ZigBee/IRQ1/IRTC
PA13	SCK2	TIOA0	A21-NALE	SEG7	–		Backlight On/off
PA14	RTS2	TIOB0	A20	SEG8	WKUP3		RS232/485
PA15	CTS2	TIOA4	A19	SEG9	–		RS232/485
PA16	SCK1	TIOB4	A18	SEG10	–		MuxLCD
PA17	RTS1	TCLK4	A17	SEG11	WKUP7		ZigBee / RST
PA18	CTS1	TIOA5	A16	SEG12	–		ZigBee / SLPTR
PA19	RTS0	TCLK5	A15	SEG13	WKUP4		PB ScrUp
PA20	CTS0	TIOB5	A14	SEG14	–		PB ScrDwn
PA21	SPI0_NPCS1	–	A13	SEG15	–		ZigBee / NPCS
PA22	SPI0_NPCS2	–	A12	SEG16	–		ZigBit / IRQ
PA23	SPI0_NPCS3	–	A11	SEG17	–		–
PA24	TWD0	–	A10	SEG18	WKUP1		TWI / ZigBit
PA25	TWCK0	–	A9	SEG19	–		TWI / ZigBit
PA26	CTS4	–	A8	SEG20	–		–
PA27	–	–	NCS0	SEG21	–	–	
PA28	–	–	NRD	SEG22	–	–	
PA29	PCK1	–	NWAIT	SEG23	–	–	MCLK (ATSense)
PA30	PCK1	–	A15	–	XOUT	XOUT	–
PA31	PCK0	–	A14	–	XIN	XIN	–