



Chipsmall Limited consists of a professional team with an average of over 10 year of expertise in the distribution of electronic components. Based in Hongkong, we have already established firm and mutual-benefit business relationships with customers from,Europe,America and south Asia,supplying obsolete and hard-to-find components to meet their specific needs.

With the principle of “Quality Parts,Customers Priority,Honest Operation,and Considerate Service”,our business mainly focus on the distribution of electronic components. Line cards we deal with include Microchip,ALPS,ROHM,Xilinx,Pulse,ON,Everlight and Freescale. Main products comprise IC,Modules,Potentiometer,IC Socket,Relay,Connector.Our parts cover such applications as commercial,industrial, and automotives areas.

We are looking forward to setting up business relationship with you and hope to provide you with the best service and solution. Let us make a better world for our industry!



Contact us

Tel: +86-755-8981 8866 Fax: +86-755-8427 6832

Email & Skype: info@chipsmall.com Web: www.chipsmall.com

Address: A1208, Overseas Decoration Building, #122 Zhenhua RD., Futian, Shenzhen, China



Summary

Atmel's SAM4L series is a member of a family of Flash microcontrollers based on the high performance 32-bit ARM Cortex-M4 RISC processor running at frequencies up to 48MHz.

The SAM4L series embeds state-of-the-art picoPower technology for ultra-low power consumption. Combined power control techniques are used to bring active current consumption down to 90µA/MHz. The device allows a wide range of options between functionality and power consumption, giving the user the ability to reach the lowest possible power consumption with the feature set required for the application. The WAIT and RETENTION modes provide full logic and RAM retention, associated with fast wake-up capability (<1.5µs) and a very low consumption of, respectively, 3 µA and 1.5 µA. In addition, WAIT mode supports SleepWalking features. In BACKUP mode, CPU, peripherals and RAM are powered off and, while consuming less than 0.9µA with external interrupt wake-up supported.

The SAM4L series offers a wide range of peripherals such as segment LCD controller, embedded hardware capacitive touch (QTouch), USB device & embedded host, 128-bit AES and audio interfaces in addition to high speed serial peripherals such as USART, SPI and I²C. Additionally the Peripheral Event System and SleepWalking allows the peripherals to communicate directly with each other and make intelligent decisions and decide to wake-up the system on a qualified events on a peripheral level; such as I²C address match or and ADC threshold.

Features

- Core
 - ARM[®] Cortex[™]-M4 running at up to 48MHz
 - Memory Protection Unit (MPU)
 - Thumb[®]-2 instruction set
- picoPower[®] Technology for Ultra-low Power Consumption
 - Active mode down to 90µA/MHz with configurable voltage scaling
 - High performance and efficiency: 28 coremark/mA
 - Wait mode down to 3µA with fast wake-up time (<1.5µs) supporting SleepWalking
 - Full RAM and Logic Retention mode down to 1.5µA with fast wake-up time (<1.5µs)
 - Ultra low power Backup mode with/without RTC down to 1,5/0.9µA
- Memories
 - From 128 to 512Kbytes embedded Flash, 64-bit wide access,
 - 0 wait-state capability up to 24MHz
 - up to 64Kbytes embedded SRAM
- System Functions
 - Embedded voltage linear and switching regulator for single supply operation
 - Two Power-on-Reset and Two Brown-out Detectors (BOD)
 - Quartz or ceramic resonator oscillators: 0.6 to 30MHz main power with Failure Detection and low power 32.768 kHz for RTC or device clock
 - High precision 4/8/12MHz factory trimmed internal RC oscillator
 - Slow Clock Internal RC oscillator as permanent low-power mode device clock
 - High speed 80MHz internal RC oscillator
 - Low power 32kHz internal RC oscillator



**ATSAM
ARM-based
Flash MCU**

SAM4L Series

Summary

42023HS-11/2016



- PLL up to 240MHz for device clock and for USB
- Digital Frequency Locked Loop (DFLL) with wide input range
- Up to 16 peripheral DMA (PDCA) channels
- **Peripherals**
 - USB 2.0 Device and Embedded Host: 12 Mbps, up to 8 bidirectional Endpoints and Multi-packet Ping-pong Mode. On-Chip Transceiver
 - Liquid Crystal Display (LCD) Module with Capacity up to 40 Segments and up to 4 Common Terminals
 - One USART with ISO7816, IrDA®, RS-485, SPI, Manchester and LIN Mode
 - Three USART with SPI Mode
 - One PicoUART for extended UART wake-up capabilities in all sleep modes
 - Windowed Watchdog Timer (WDT)
 - Asynchronous Timer (AST) with Real-time Clock Capability, Counter or Calendar Mode Supported
 - Frequency Meter (FREQM) for Accurate Measuring of Clock Frequency
 - Six 16-bit Timer/Counter (TC) Channels with capture, waveform, compare and PWM mode
 - One Master/Slave Serial Peripheral Interface (SPI) with Chip Select Signals
 - Four Master and Two Slave Two-wire Interfaces (TWI), up to 3.4Mbit/s I²C-compatible
 - One Advanced Encryption System (AES) with 128-bit key length
 - One 16-channel ADC 300Ksps (ADC) with up to 12 Bits Resolution
 - One DAC 500Ksps (DACC) with up to 10 Bits Resolution
 - Four Analog Comparators (ACIFC) with Optional Window Detection
 - Capacitive Touch Module (CATB) supporting up to 32 buttons
 - Audio Bitstream DAC (ABDACB) Suitable for Stereo Audio
 - Inter-IC Sound (IISC) Controller, Compliant with Inter-IC Sound (I²S) Specification
 - Peripheral Event System for Direct Peripheral to Peripheral Communication
 - 32-bit Cyclic Redundancy Check Calculation Unit (CRCCU)
 - Random generator (TRNG)
 - Parallel Capture Module (PARC)
 - Glue Logic Controller (GLOC)
- **I/O**
 - Up to 75 I/O lines with external interrupt capability (edge or level sensitivity), debouncing, glitch filtering and slew-rate control
 - Up to Six High-drive I/O Pins
- **Single 1.68-3.6V Power Supply**
- **Packages**
 - 100-lead LQFP, 14 x 14 mm, pitch 0.5 mm/100-ball VFBGA, 7x7 mm, pitch 0.65 mm
 - 64-lead LQFP, 10 x 10 mm, pitch 0.5 mm/64-pad QFN 9x9 mm, pitch 0.5 mm
 - 64-ball WLCSP, 4,314x4,434 mm, pitch 0.5 mm for SAM4LC4/2 and SAM4LS4/2 series
 - 64-ball WLCSP, 5,270x5,194 mm, pitch 0.5 mm for SAM4LC8 and SAM4LS8 series
 - 48-lead LQFP, 7 x 7 mm, pitch 0.5 mm/48-pad QFN 7x7 mm, pitch 0.5 mm

1. Description

Atmel's SAM4L series is a member of a family of Flash microcontrollers based on the high performance 32-bit ARM Cortex-M4 RISC processor running at frequencies up to 48MHz.

The processor implements a Memory Protection Unit (MPU) and a fast and flexible interrupt controller for supporting modern and real-time operating systems.

The ATSAM4L8/L4/L2 embeds state-of-the-art picoPower technology for ultra-low power consumption. Combined power control techniques are used to bring active current consumption down to 90µA/MHz. The device allows a wide range of options between functionality and power consumption, giving the user the ability to reach the lowest possible power consumption with the feature set required for the application. On-chip regulator improves power efficiency when used in swichting mode with an external inductor or can be used in linear mode if application is noise sensitive.

The ATSAM4L8/L4/L2 supports 4 power saving strategies. The SLEEP mode put the CPU in idle mode and offers different sub-modes which automatically switch off/on bus clocks, PLL, oscillators. The WAIT and RETENTION modes provide full logic and RAM retention, associated with fast wake-up capability (<1.5µs) and a very low consumption of, respectively, 3 µA and 1.5 µA. In addition, WAIT mode supports SleepWalking features. In BACKUP mode, CPU, peripherals and RAM are powered off and, while consuming less than 0.5µA, the device is able to wake-up from external interrupts.

The ATSAM4L8/L4/L2 incorporates on-chip Flash tightly coupled to a low power cache (LPCACHE) for active consumption optimization and SRAM memories for fast access.

The LCD controller is intended for monochrome passive liquid crystal display (LCD) with up to 4 Common terminals and up to 40 Segments terminals. Dedicated Low Power Waveform, Contrast Control, Extended Interrupt Mode, Selectable Frame Frequency and Blink functionality are supported to offload the CPU, reduce interrupts and reduce power consumption. The controller includes integrated LCD buffers and integrated power supply voltage.

The low-power and high performance capacitive touch module (CATB) is introduced to meet the demand for a low power capacitive touch solution that could be used to handle buttons, sliders and wheels. The CATB provides excellent signal performance, as well as autonomous touch and proximity detection for up to 32 sensors. This solution includes an advanced sequencer in addition to an hardware filtering unit.

The Advanced Encryption Standard module (AES) is compliant with the *FIPS (Federal Information Processing Standard) Publication 197, Advanced Encryption Standard (AES)*, which specifies a symmetric block cipher that is used to encrypt and decrypt electronic data. *Encryption* is the transformation of a usable message, called the *plaintext*, into an unreadable form, called the *ciphertext*. On the other hand, *decryption* is the transformation that recovers the plaintext from the ciphertext. AESA supports 128 bits cryptographic key sizes.

The Peripheral Direct Memory Access (DMA) controller enables data transfers between peripherals and memories without processor involvement. The Peripheral DMA controller drastically reduces processing overhead when transferring continuous and large data streams.

The Peripheral Event System (PES) allows peripherals to receive, react to, and send peripheral events without CPU intervention. Asynchronous interrupts allow advanced peripheral operation in low power modes.

The Power Manager (PM) improves design flexibility and security. The Power Manager supports SleepWalking functionality, by which a module can be selectively activated based on peripheral

events, even in sleep modes where the module clock is stopped. Power monitoring is supported by on-chip Power-on Reset (POR18, POR33), Brown-out Detectors (BOD18, BOD33). The device features several oscillators, such as Phase Locked Loop (PLL), Digital Frequency Locked Loop (DFLL), Oscillator 0 (OSC0), Internal RC 4,8,12MHz oscillator (RCFAST), system RC oscillator (RCSYS), Internal RC 80MHz, Internal 32kHz RC and 32kHz Crystal Oscillator. Either of these oscillators can be used as source for the system clock. The DFLL is a programmable internal oscillator from 40 to 150MHz. It can be tuned to a high accuracy if an accurate reference clock is running, e.g. the 32kHz crystal oscillator.

The Watchdog Timer (WDT) will reset the device unless it is periodically serviced by the software. This allows the device to recover from a condition that has caused the system to be unstable.

The Asynchronous Timer (AST) combined with the 32kHz crystal oscillator supports powerful real-time clock capabilities, with a maximum timeout of up to 136 years. The AST can operate in counter or calendar mode.

The Frequency Meter (FREQM) allows accurate measuring of a clock frequency by comparing it to a known reference clock.

The Full-speed USB 2.0 device and embedded host interface (USBC) supports several USB classes at the same time utilizing the rich end-point configuration.

The device includes six identical 16-bit Timer/Counter (TC) channels. Each channel can be independently programmed to perform frequency measurement, event counting, interval measurement, pulse generation, delay timing, and pulse width modulation.

The ATSAM4L8/L4/L2 also features many communication interfaces, like USART, SPI, or TWI, for communication intensive applications. The USART supports different communication modes, like SPI Mode and LIN Mode.

A general purpose 16-channel ADC is provided, as well as four analog comparators (ACIFC). The ADC can operate in 12-bit mode at full speed. The analog comparators can be paired to detect when the sensing voltage is within or outside the defined reference window.

Atmel offers the QTouch Library for embedding capacitive touch buttons, sliders, and wheels functionality. The patented charge-transfer signal acquisition offers robust sensing and includes fully debounced reporting of touch keys as well as Adjacent Key Suppression® (AKS®) technology for unambiguous detection of key events. The easy-to-use QTouch Suite toolchain allows you to explore, develop, and debug your own touch applications.

The Audio Bitstream DAC (ABDACB) converts a 16-bit sample value to a digital bitstream with an average value proportional to the sample value. Two channels are supported, making the ABDAC particularly suitable for stereo audio.

The Inter-IC Sound Controller (IISC) provides a 5-bit wide, bidirectional, synchronous, digital audio link with external audio devices. The controller is compliant with the Inter-IC Sound (I2S) bus specification.

2. Overview

2.1 Block Diagram

Figure 2-1. Block Diagram

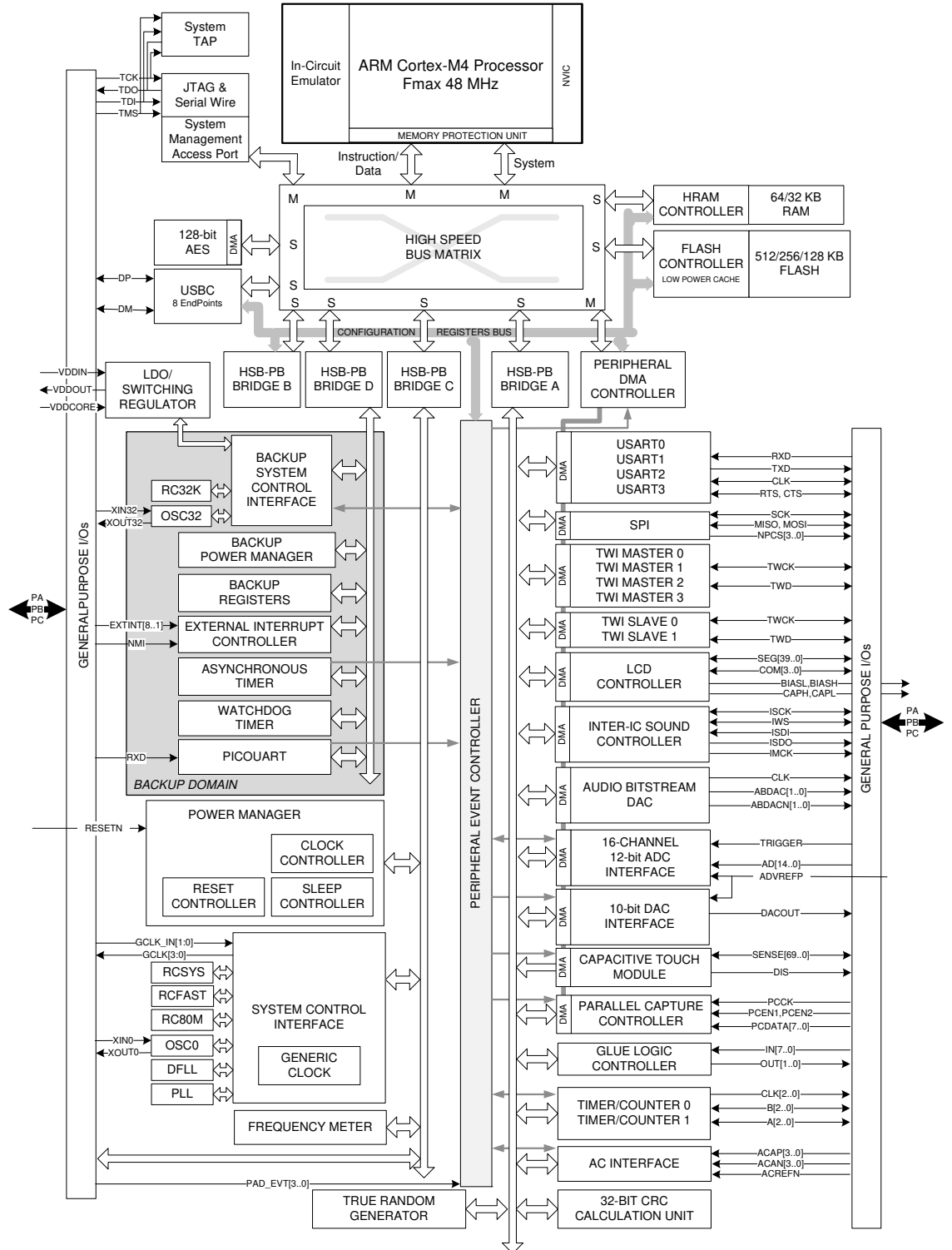

2.2 Configuration Summary

Table 2-1. Sub Series Summary

Feature	ATSAM4LC	ATSAM4LS
SEGMENT LCD	Yes	No
AESA	Yes	No
USB	Device + Host	Device Only

Table 2-2. ATSAM4LC Configuration Summary

Feature	ATSAM4LC8/4/2C	ATSAM4LC8/4/2B	ATSAM4LC8/4/2A
Number of Pins	100	64	48
Max Frequency	48MHz		
Flash	512/256/128KB		
SRAM	64/32/32KB		
SEGMENT LCD	4x40	4x23	4x13
GPIO	75	43	27
High-drive pins	6	3	1
External Interrupts	8 + 1 NMI		
TWI	2 Masters + 2 Masters/Slaves		1 Master + 1 Master/Slave
USART	4		3 in LC sub series 4 in LS sub series
PICOUART	1		0
Peripheral DMA Channels	16		
AESA	1		
Peripheral Event System	1		
SPI	1		
Asynchronous Timers	1		
Timer/Counter Channels	6	3	
Parallel Capture Inputs	8		
Frequency Meter	1		
Watchdog Timer	1		
Power Manager	1		
Glue Logic LUT	2		1

Table 2-2. ATSAM4LC Configuration Summary

Feature	ATSAM4LC8/4/2C	ATSAM4LC8/4/2B	ATSAM4LC8/4/2A
Oscillators	Digital Frequency Locked Loop 20-150MHz (DFLL) Phase Locked Loop 48-240MHz (PLL) Crystal Oscillator 0.6-30MHz (OSC0) Crystal Oscillator 32kHz (OSC32K) RC Oscillator 80MHz (RC80M) RC Oscillator 4,8,12MHz (RCFAST) RC Oscillator 115kHz (RCSYS) RC Oscillator 32kHz (RC32K)		
ADC	15-channel	7-channel	3-channel
DAC	1-channel		
Analog Comparators	4	2	1
CATB Sensors	32	32	26
USB	1		
Audio Bitstream DAC	1		
IIS Controller	1		
Packages	TQFP/VFBGA	TQFP/QFN/ WLCSP	TQFP/QFN

Table 2-3. ATSAM4LS Configuration Summary

Feature	ATSAM4LS8/4/2C	ATSAM4LS8/4/2B	ATSAM4LS8/4/2A
Number of Pins	100	64	48
Max Frequency	48MHz		
Flash	512/256/128KB		
SRAM	64/32/32KB		
SEGMENT LCD	NA		
GPIO	80	48	32
High-drive pins	6	3	1
External Interrupts	8 + 1 NMI		
TWI	2 Masters + 2 Masters/Slaves		1 Master + 1 Master/Slave
USART	4		3 in LC sub series 4 in LS sub series
PICOUART	1		0
Peripheral DMA Channels	16		
AESA	NA		
Peripheral Event System	1		
SPI	1		
Asynchronous Timers	1		

Table 2-3. ATSAM4LS Configuration Summary

Feature	ATSAM4LS8/4/2C	ATSAM4LS8/4/2B	ATSAM4LS8/4/2A
Timer/Counter Channels	6	3	
Parallel Capture Inputs	8		
Frequency Meter	1		
Watchdog Timer	1		
Power Manager	1		
Glue Logic LUT	2	1	
Oscillators	Digital Frequency Locked Loop 20-150MHz (DFLL) Phase Locked Loop 48-240MHz (PLL) Crystal Oscillator 0.6-30MHz (OSC0) Crystal Oscillator 32kHz (OSC32K) RC Oscillator 80MHz (RC80M) RC Oscillator 4,8,12MHz (RCFAST) RC Oscillator 115kHz (RCSYS) RC Oscillator 32kHz (RC32K)		
ADC	15-channel	7-channel	3-channel
DAC	1-channel		
Analog Comparators	4	2	1
CATB Sensors	32	32	26
USB	1		
Audio Bitstream DAC	1		
IIS Controller	1		
Packages	TQFP/VFBGA	TQFP/QFN/ WLCSP	TQFP/QFN

Figure 3-2. ATSAM4LC VFBGA100 Pinout

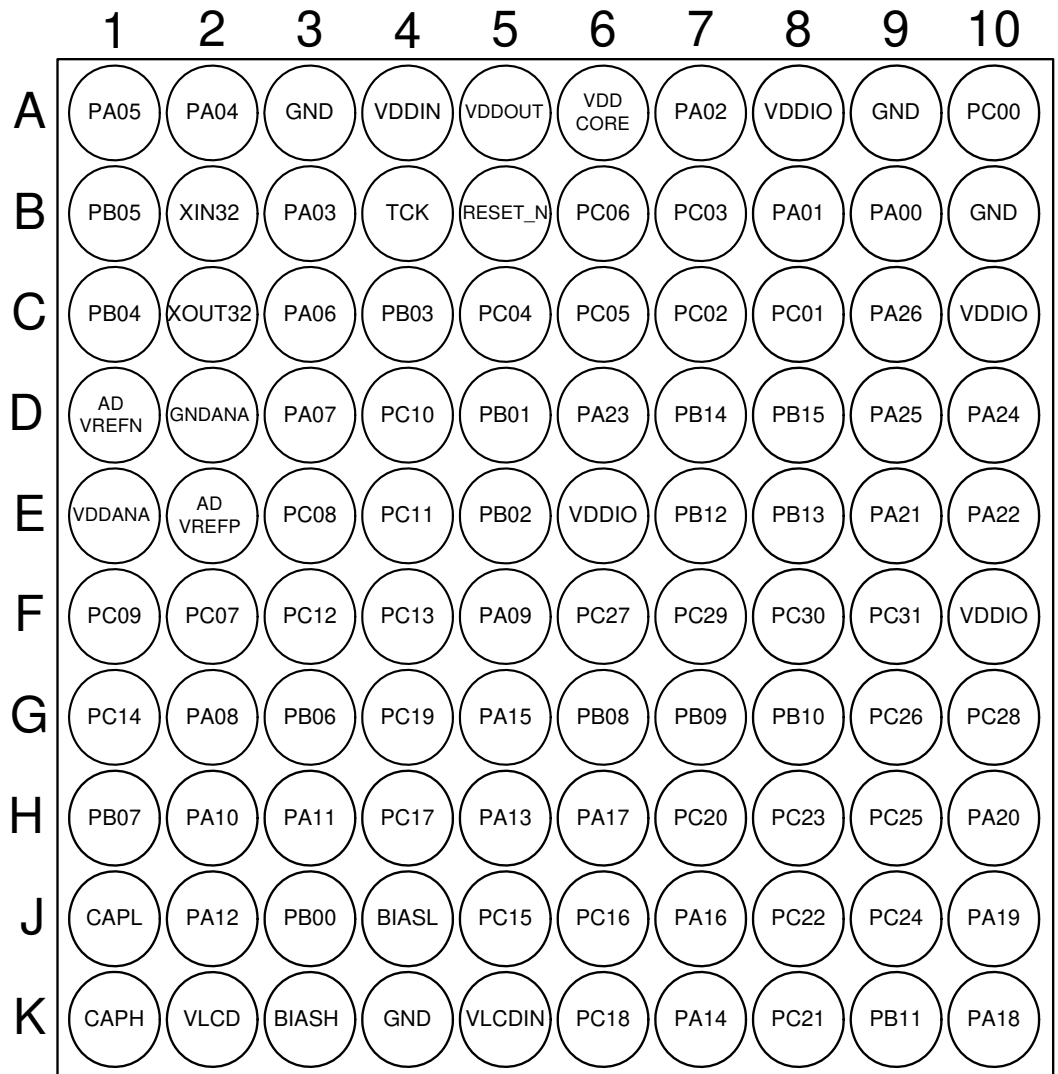

Figure 3-3. ATSAM4LC WLCSP64 Pinout

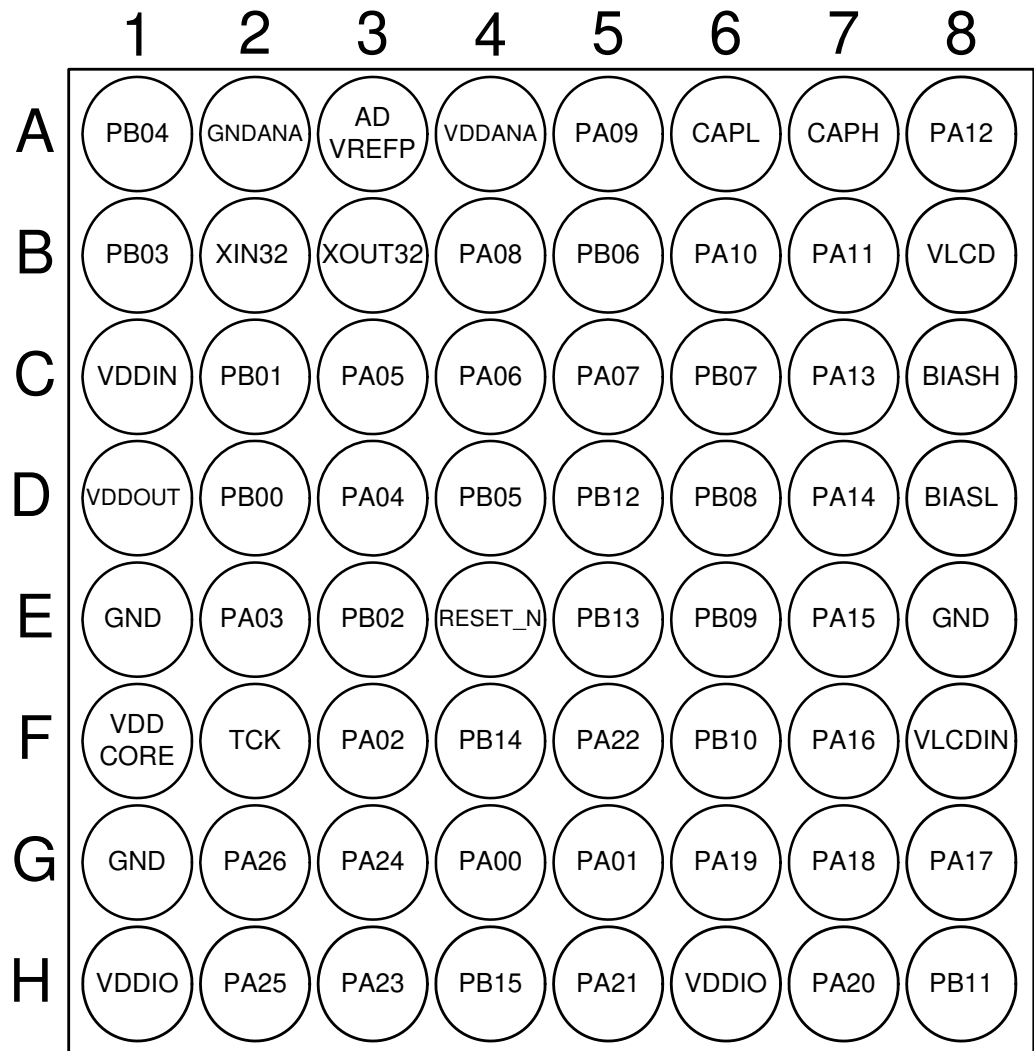

Figure 3-4. ATSAM4LC TQFP64/QFN64 Pinout

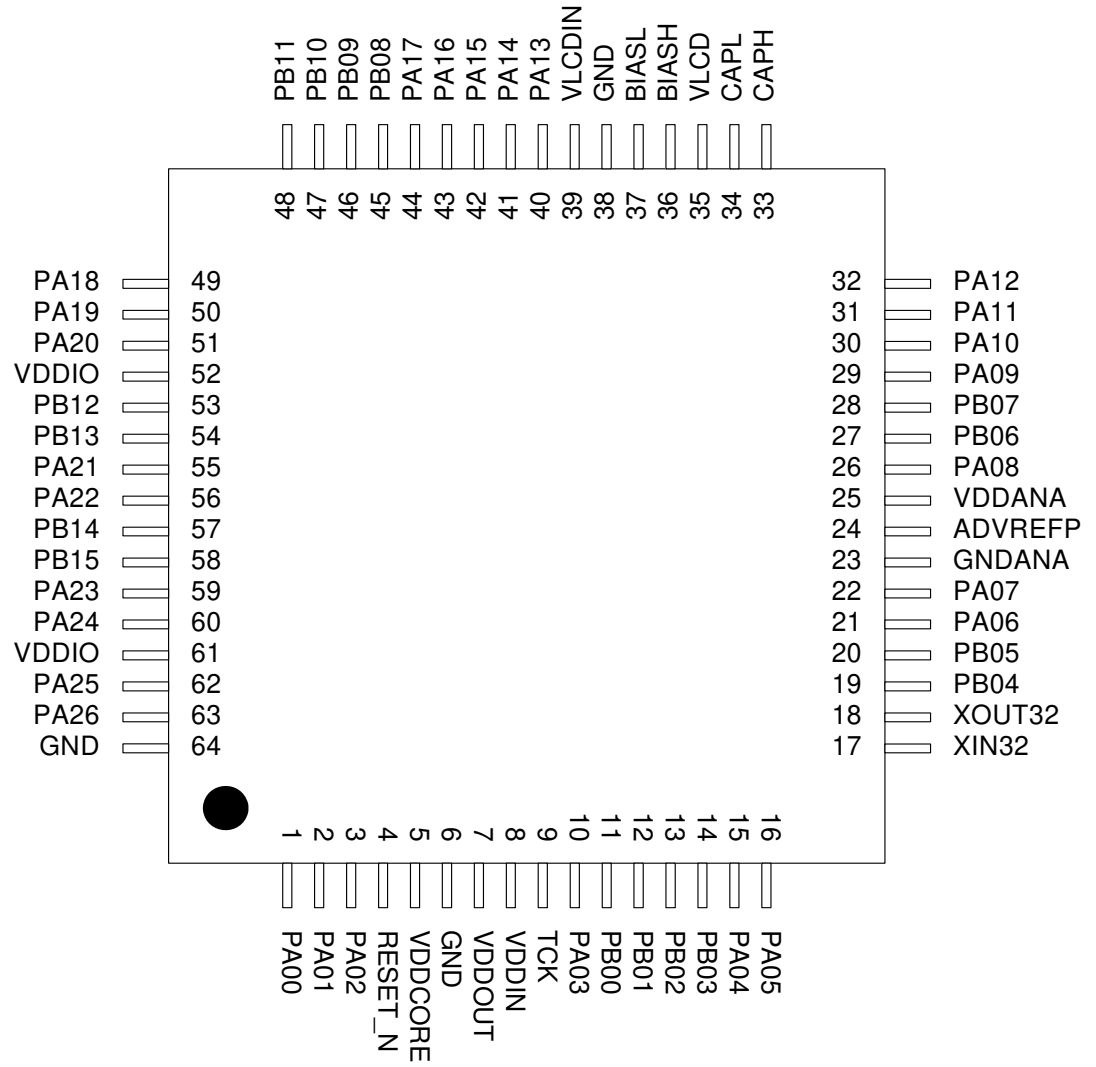
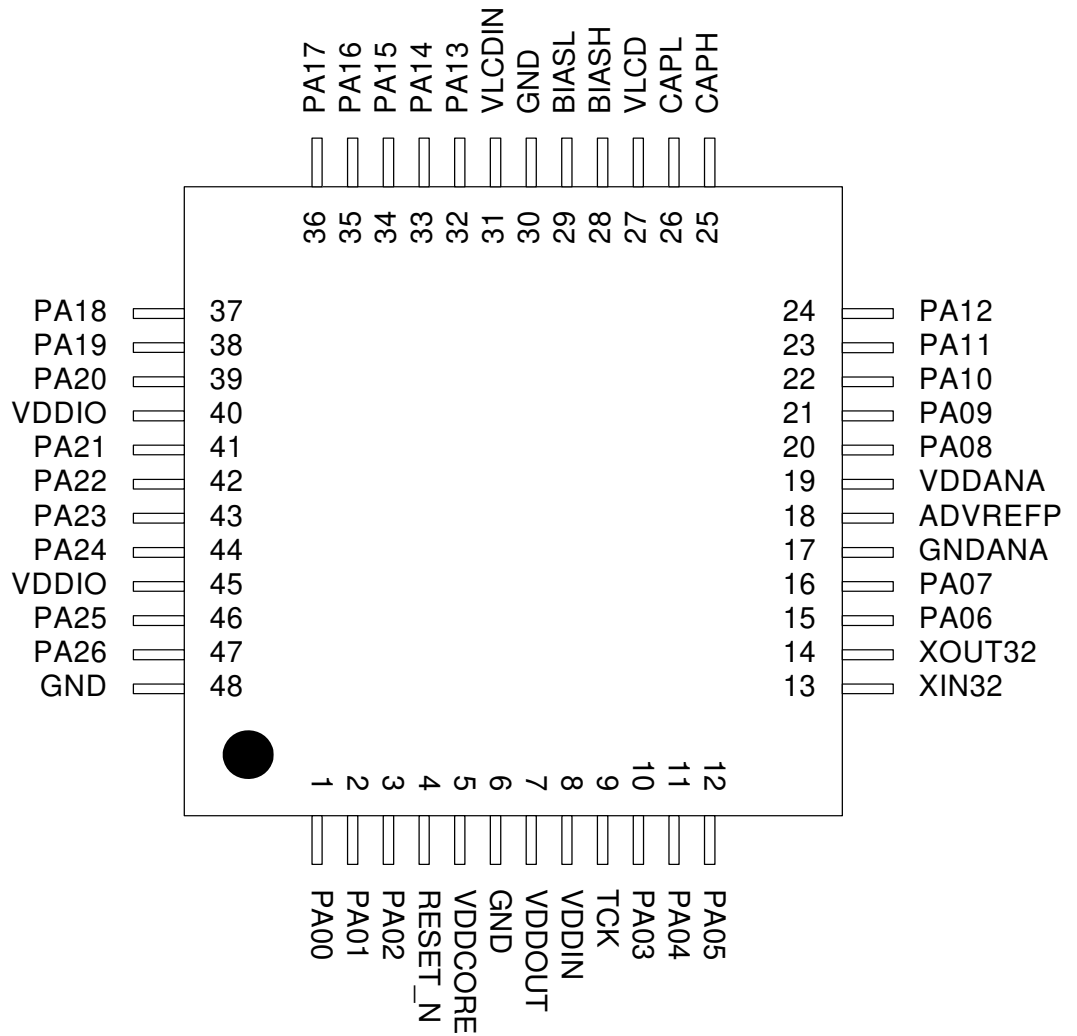

Figure 3-5. ATSAM4LC TQFP48/QFN48 Pinout



3.1.2 ATSAM4LSx Pinout

Figure 3-6. ATSAM4LS TQFP100 Pinout

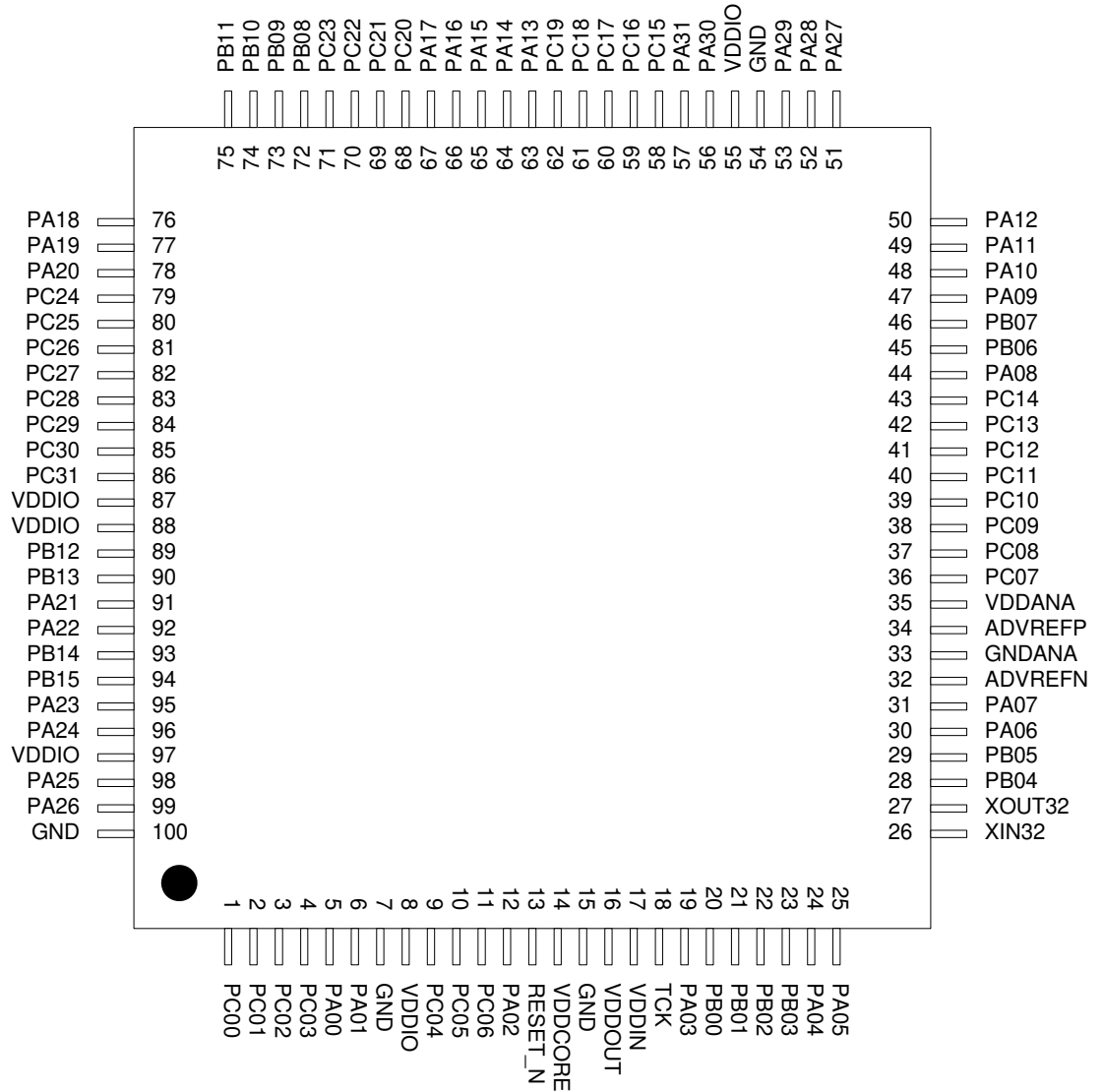

Figure 3-7. ATSAM4LS VFBGA100 Pinout

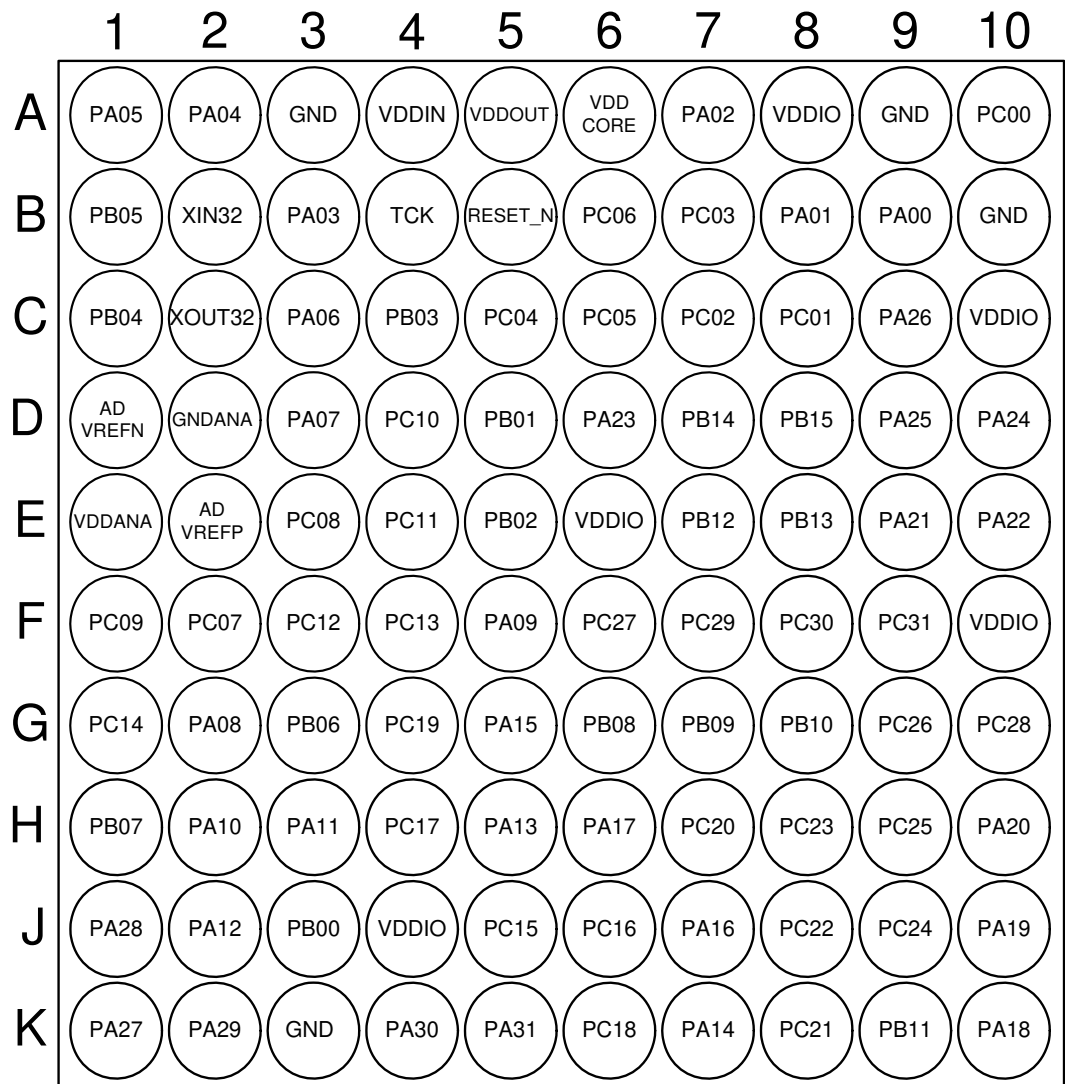

Figure 3-8. ATSAM4LS WLCSP64 Pinout

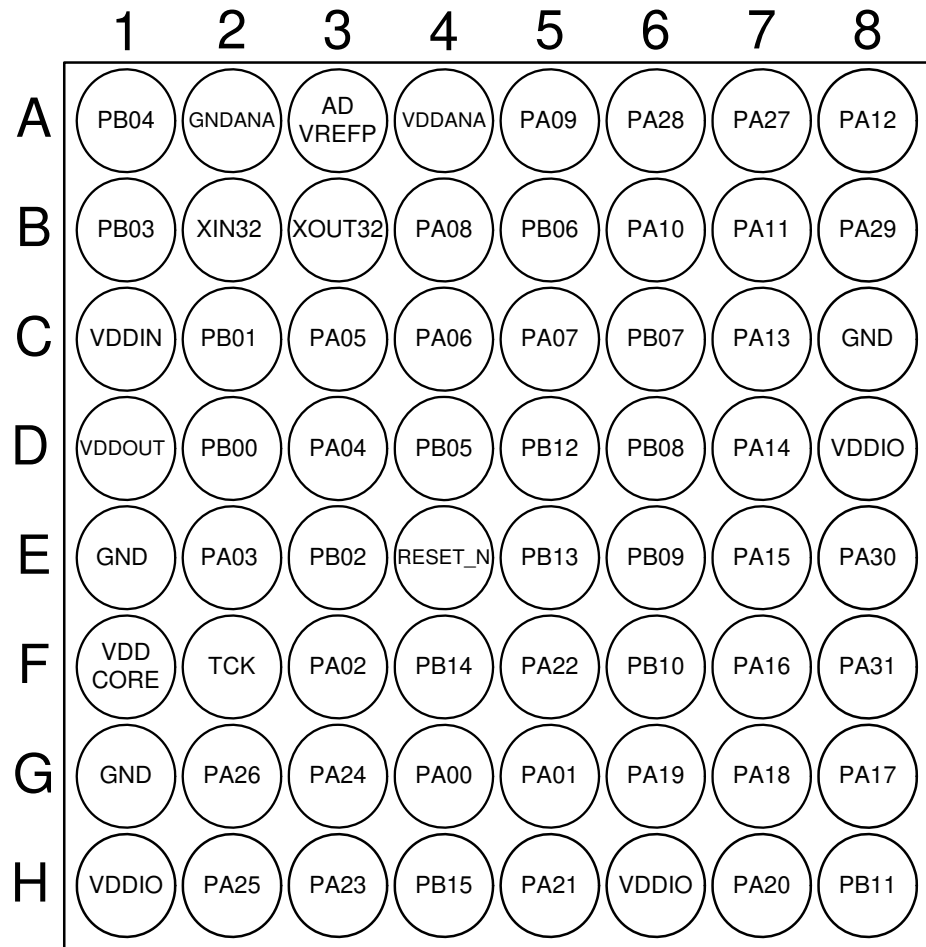

Figure 3-9. ATSAM4LS TQFP64/QFN64 Pinout

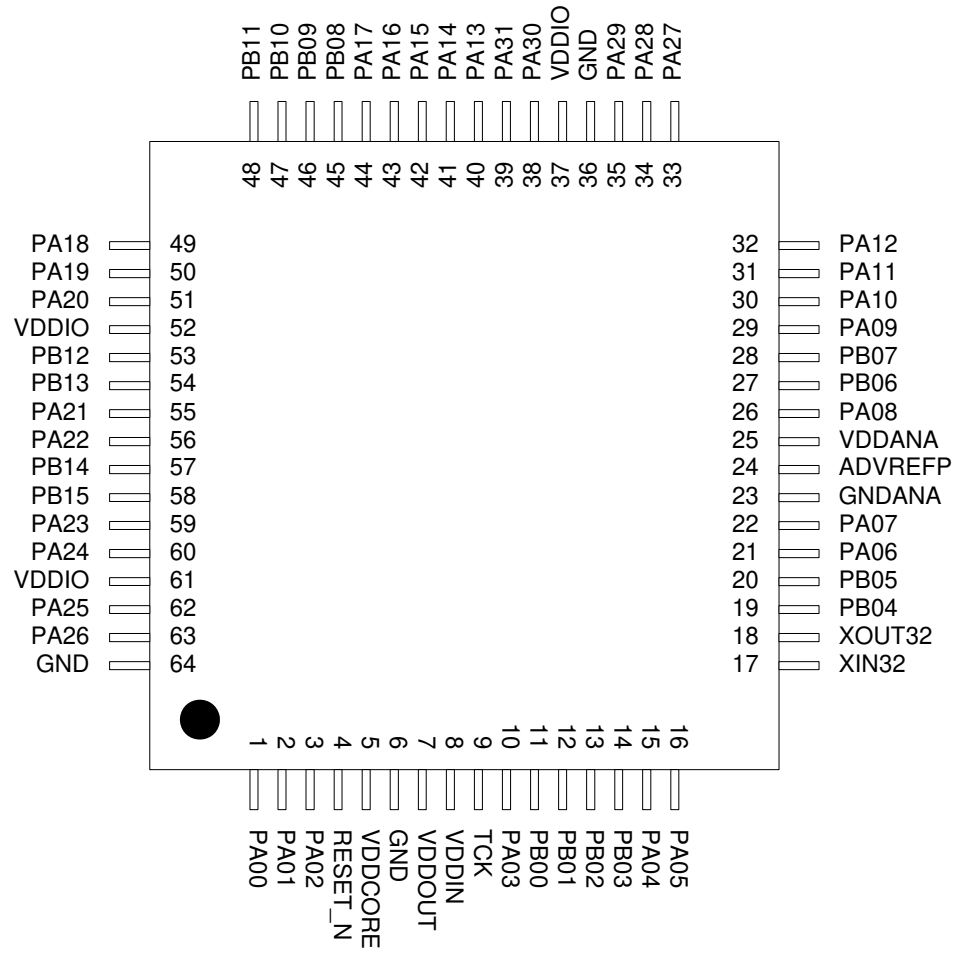
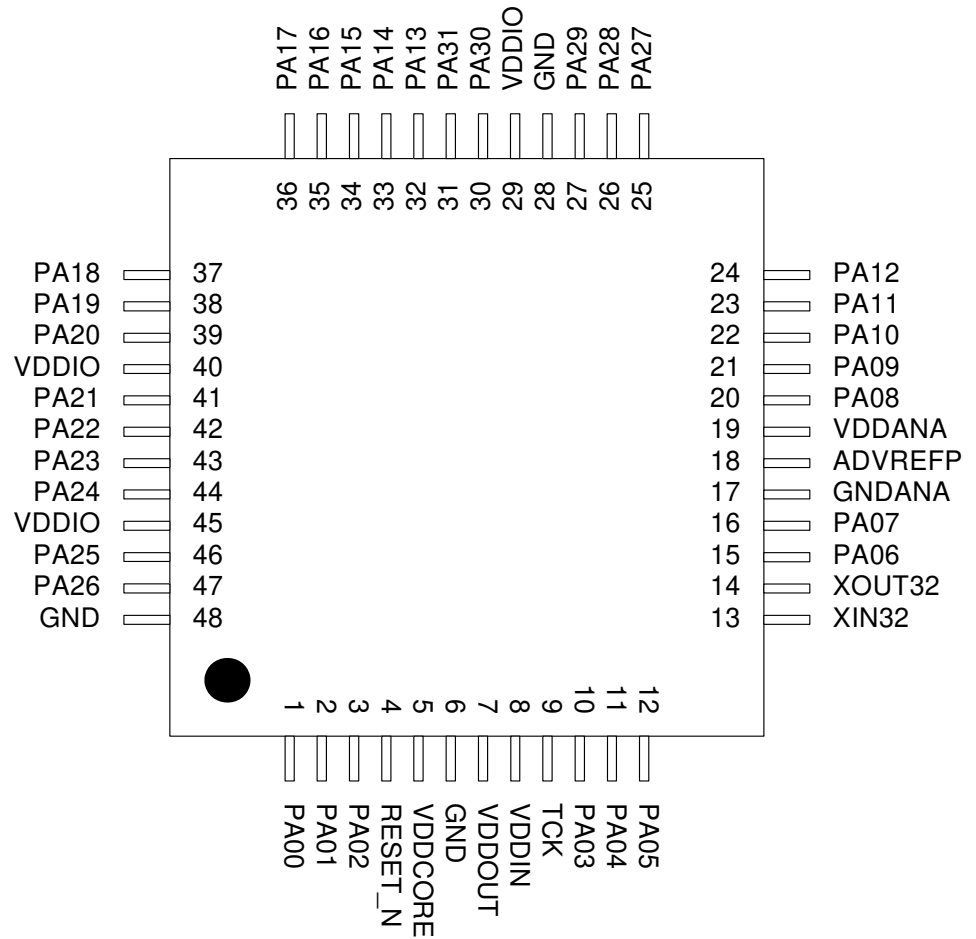

Figure 3-10. ATSAM4LS TQFP48/QFN48 Pinout



See [Section 3.3 "Signals Description" on page 31](#) for a description of the various peripheral signals.

Refer to ["Electrical Characteristics" on page 99](#) for a description of the electrical properties of the pin types used.

3.2 Peripheral Multiplexing on I/O lines

3.2.1 Multiplexed Signals

Each GPIO line can be assigned to one of the peripheral functions. The following tables ([Section 3-1 "100-pin GPIO Controller Function Multiplexing" on page 19](#) to [Section 3-4 "48-pin GPIO Controller Function Multiplexing" on page 28](#)) describes the peripheral signals multiplexed to the GPIO lines.

Peripheral functions that are not relevant in some parts of the family are grey-shaded.

For description of different Supply voltage source, refer to the [Section 6. "Power and Startup Considerations" on page 46](#).

Table 3-1. 100-pin GPIO Controller Function Multiplexing (Sheet 1 of 4)

ATSAM4LC		ATSAM4LS		Pin	GPIO	Supply	GPIO Functions								
QFN	VFBGA	QFN	VFBGA				A	B	C	D	E	F	G		
5	B9	5	B9	PA00	0	VDDIO									
6	B8	6	B8	PA01	1	VDDIO									
12	A7	12	A7	PA02	2	VDDIN	SCIF GCLK0	SPI NPCS0							CATB DIS
19	B3	19	B3	PA03	3	VDDIN		SPI MISO							
24	A2	24	A2	PA04	4	VDDANA	ADCIFE AD0	USART0 CLK	EIC EXTINT2	GLOC IN1					CATB SENSE0
25	A1	25	A1	PA05	5	VDDANA	ADCIFE AD1	USART0 RXD	EIC EXTINT3	GLOC IN2	ADCIFE TRIGGER				CATB SENSE1
30	C3	30	C3	PA06	6	VDDANA	DACC VOUT	USART0 RTS	EIC EXTINT1	GLOC IN0	ACIFC ACAN0				CATB SENSE2
31	D3	31	D3	PA07	7	VDDANA	ADCIFE AD2	USART0 TXD	EIC EXTINT4	GLOC IN3	ACIFC ACAP0				CATB SENSE3
44	G2	44	G2	PA08	8	LCDA	USART0 RTS	TC0 A0	PEVC PAD EVT0	GLOC OUT0		LCDCA SEG23			CATB SENSE4
47	F5	47	F5	PA09	9	LCDA	USART0 CTS	TC0 B0	PEVC PAD EVT1	PARC PCDATA0		LCDCA COM3			CATB SENSE5
48	H2	48	H2	PA10	10	LCDA	USART0 CLK	TC0 A1	PEVC PAD EVT2	PARC PCDATA1		LCDCA COM2			CATB SENSE6
49	H3	49	H3	PA11	11	LCDA	USART0 RXD	TC0 B1	PEVC PAD EVT3	PARC PCDATA2		LCDCA COM1			CATB SENSE7
50	J2	50	J2	PA12	12	LCDA	USART0 TXD	TC0 A2		PARC PCDATA3		LCDCA COM0			CATB DIS
63	H5	63	H5	PA13	13	LCDA	USART1 RTS	TC0 B2	SPI NPCS1	PARC PCDATA4		LCDCA SEG5			CATB SENSE8
64	K7	64	K7	PA14	14	LCDA	USART1 CLK	TC0 CLK0	SPI NPCS2	PARC PCDATA5		LCDCA SEG6			CATB SENSE9
65	G5	65	G5	PA15	15	LCDA	USART1 RXD	TC0 CLK1	SPI NPCS3	PARC PCDATA6		LCDCA SEG7			CATB SENSE10

Table 3-1. 100-pin GPIO Controller Function Multiplexing (Sheet 2 of 4)

ATSAM4LC		ATSAM4LS		Pin	GPIO	Supply	GPIO Functions						
QFN	VFBGA	QFN	VFBGA				A	B	C	D	E	F	G
66	J7	66	J7	PA16	16	LCDA	USART1 TXD	TC0 CLK2	EIC EXTINT1	PARC PCDATA7		LCDCA SEG8	CATB SENSE11
67	H6	67	H6	PA17	17	LCDA	USART2 RTS	ABDACB DAC0	EIC EXTINT2	PARC PCK		LCDCA SEG9	CATB SENSE12
76	K10	76	K10	PA18	18	LCDA	USART2 CLK	ABDACB DACN0	EIC EXTINT3	PARC PCEN1		LCDCA SEG18	CATB SENSE13
77	J10	77	J10	PA19	19	LCDA	USART2 RXD	ABDACB DAC1	EIC EXTINT4	PARC PCEN2	SCIF GCLK0	LCDCA SEG19	CATB SENSE14
78	H10	78	H10	PA20	20	LCDA	USART2 TXD	ABDACB DACN1	EIC EXTINT5	GLOC IN0	SCIF GCLK1	LCDCA SEG20	CATB SENSE15
91	E9	91	E9	PA21	21	LCDC	SPI MISO	USART1 CTS	EIC EXTINT6	GLOC IN1	TWIM2 TWD	LCDCA SEG34	CATB SENSE16
92	E10	92	E10	PA22	22	LCDC	SPI MOSI	USART2 CTS	EIC EXTINT7	GLOC IN2	TWIM2 TWCK	LCDCA SEG35	CATB SENSE17
95	D6	95	D6	PA23	23	LCDC	SPI SCK	TWIMS0 TWD	EIC EXTINT8	GLOC IN3	SCIF GCLK IN0	LCDCA SEG38	CATB DIS
96	D10	96	D10	PA24	24	LCDC	SPI NPCS0	TWIMS0 TWCK		GLOC OUT0	SCIF GCLK IN1	LCDCA SEG39	CATB SENSE18
98	D9	98	D9	PA25	25	VDDIO	USBC DM	USART2 RXD					CATB SENSE19
99	C9	99	C9	PA26	26	VDDIO	USBC DP	USART2 TXD					CATB SENSE20
			51	K1	27	LCDA	SPI MISO	IISC ISCK	ABDACB DAC0	GLOC IN4	USART3 RTS		CATB SENSE0
			52	J1	28	LCDA	SPI MOSI	IISC ISDI	ABDACB DACN0	GLOC IN5	USART3 CTS		CATB SENSE1
			53	K2	29	LCDA	SPI SCK	IISC IWS	ABDACB DAC1	GLOC IN6	USART3 CLK		CATB SENSE2
			56	K4	30	LCDA	SPI NPCS0	IISC ISDO	ABDACB DACN1	GLOC IN7	USART3 RXD		CATB SENSE3
			57	K5	31	LCDA	SPI NPCS1	IISC IMCK	ABDACB CLK	GLOC OUT1	USART3 TXD		CATB DIS
20	J3	20	J3	PB00	32	VDDIN	TWIMS1 TWD	USART0 RXD					CATB SENSE21
21	D5	21	D5	PB01	33	VDDIN	TWIMS1 TWCK	USART0 TXD	EIC EXTINT0				CATB SENSE22
22	E5	22	E5	PB02	34	VDDANA	ADCIFE AD3	USART1 RTS	ABDACB DAC0	IISC ISCK	ACIFC ACBN0		CATB SENSE23
23	C4	23	C4	PB03	35	VDDANA	ADCIFE AD4	USART1 CLK	ABDACB DACN0	IISC ISDI	ACIFC ACBP0		CATB DIS
28	C1	28	C1	PB04	36	VDDANA	ADCIFE AD5	USART1 RXD	ABDACB DAC1	IISC ISDO	DACC EXT TRIG0		CATB SENSE24
29	B1	29	B1	PB05	37	VDDANA	ADCIFE AD6	USART1 TXD	ABDACB DACN1	IISC IMCK			CATB SENSE25
45	G3	45	G3	PB06	38	LCDA	USART3 RTS		GLOC IN4	IISC IWS		LCDCA SEG22	CATB SENSE26
46	H1	46	H1	PB07	39	LCDA	USART3 CTS		GLOC IN5	TC0 A0		LCDCA SEG21	CATB SENSE27

Table 3-1. 100-pin GPIO Controller Function Multiplexing (Sheet 3 of 4)

ATSAM4LC		ATSAM4LS		Pin	GPIO	Supply	GPIO Functions						
QFN	VFBGA	QFN	VFBGA				A	B	C	D	E	F	G
72	G6	72	G6	PB08	40	LCDA	USART3 CLK		GLOC IN6	TC0 B0		LCDCA SEG14	CATB SENSE28
73	G7	73	G7	PB09	41	LCDA	USART3 RXD	PEVC PAD EVT2	GLOC IN7	TC0 A1		LCDCA SEG15	CATB SENSE29
74	G8	74	G8	PB10	42	LCDA	USART3 TXD	PEVC PAD EVT3	GLOC OUT1	TC0 B1	SCIF GCLK0	LCDCA SEG16	CATB SENSE30
75	K9	75	K9	PB11	43	LCDA	USART0 CTS	SPI NPCS2		TC0 A2	SCIF GCLK1	LCDCA SEG17	CATB SENSE31
89	E7	89	E7	PB12	44	LCDC	USART0 RTS	SPI NPCS3	PEVC PAD EVT0	TC0 B2	SCIF GCLK2	LCDCA SEG32	CATB DIS
90	E8	90	E8	PB13	45	LCDC	USART0 CLK	SPI NPCS1	PEVC PAD EVT1	TC0 CLK0	SCIF GCLK3	LCDCA SEG33	CATB SENSE0
93	D7	93	D7	PB14	46	LCDC	USART0 RXD	SPI MISO	TWIM3 TWD	TC0 CLK1	SCIF GCLK IN0	LCDCA SEG36	CATB SENSE1
94	D8	94	D8	PB15	47	LCDC	USART0 TXD	SPI MOSI	TWIM3 TWCK	TC0 CLK2	SCIF GCLK IN1	LCDCA SEG37	CATB SENSE2
1	A10	1	A10	PC00	64	VDDIO	SPI NPCS2	USART0 CLK		TC1 A0			CATB SENSE3
2	C8	2	C8	PC01	65	VDDIO	SPI NPCS3	USART0 RTS		TC1 B0			CATB SENSE4
3	C7	3	C7	PC02	66	VDDIO	SPI NPCS1	USART0 CTS	USART0 RXD	TC1 A1			CATB SENSE5
4	B7	4	B7	PC03	67	VDDIO	SPI NPCS0	EIC EXTINT5	USART0 TXD	TC1 B1			CATB SENSE6
9	C5	9	C5	PC04	68	VDDIO	SPI MISO	EIC EXTINT6		TC1 A2			CATB SENSE7
10	C6	10	C6	PC05	69	VDDIO	SPI MOSI	EIC EXTINT7		TC1 B2			CATB DIS
11	B6	11	B6	PC06	70	VDDIO	SPI SCK	EIC EXTINT8		TC1 CLK0			CATB SENSE8
36	F2	36	F2	PC07	71	VDDANA	ADCIFE AD7	USART2 RTS	PEVC PAD EVT0	TC1 CLK1			CATB SENSE9
37	E3	37	E3	PC08	72	VDDANA	ADCIFE AD8	USART2 CLK	PEVC PAD EVT1	TC1 CLK2	USART2 CTS		CATB SENSE10
38	F1	38	F1	PC09	73	VDDANA	ADCIFE AD9	USART3 RXD	ABDACB DAC0	IISC ISCK	ACIFC ACAN1		CATB SENSE11
39	D4	39	D4	PC10	74	VDDANA	ADCIFE AD10	USART3 TXD	ABDACB DACN0	IISC ISDI	ACIFC ACAP1		CATB SENSE12
40	E4	40	E4	PC11	75	VDDANA	ADCIFE AD11	USART2 RXD	PEVC PAD EVT2				CATB SENSE13
41	F3	41	F3	PC12	76	VDDANA	ADCIFE AD12	USART2 TXD	ABDACB CLK	IISC IWS			CATB SENSE14
42	F4	42	F4	PC13	77	VDDANA	ADCIFE AD13	USART3 RTS	ABDACB DAC1	IISC ISDO	ACIFC ACBN1		CATB SENSE15
43	G1	43	G1	PC14	78	VDDANA	ADCIFE AD14	USART3 CLK	ABDACB DACN1	IISC IMCK	ACIFC ACBP1		CATB DIS
58	J5	58	J5	PC15	79	LCDA	TC1 A0			GLOC IN4		LCDCA SEG0	CATB SENSE16

Table 3-1. 100-pin GPIO Controller Function Multiplexing (Sheet 4 of 4)

ATSAM4LC		ATSAM4LS		Pin	GPIO	Supply	GPIO Functions						
QFN	VFBGA	QFN	VFBGA				A	B	C	D	E	F	G
59	J6	59	J6	PC16	80	LCDA	TC1 B0			GLOC IN5		LCDCA SEG1	CATB SENSE17
60	H4	60	H4	PC17	81	LCDA	TC1 A1			GLOC IN6		LCDCA SEG2	CATB SENSE18
61	K6	61	K6	PC18	82	LCDA	TC1 B1			GLOC IN7		LCDCA SEG3	CATB SENSE19
62	G4	62	G4	PC19	83	LCDA	TC1 A2			GLOC OUT1		LCDCA SEG4	CATB SENSE20
68	H7	68	H7	PC20	84	LCDA	TC1 B2					LCDCA SEG10	CATB SENSE21
69	K8	69	K8	PC21	85	LCDA	TC1 CLK0			PARC PCCK		LCDCA SEG11	CATB SENSE22
70	J8	70	J8	PC22	86	LCDA	TC1 CLK1			PARC PCEN1		LCDCA SEG12	CATB SENSE23
71	H8	71	H8	PC23	87	LCDA	TC1 CLK2			PARC PCEN2		LCDCA SEG13	CATB DIS
79	J9	79	J9	PC24	88	LCDB	USART1 RTS	EIC EXTINT1	PEVC PAD EVT0	PARC PCDATA0		LCDCA SEG24	CATB SENSE24
80	H9	80	H9	PC25	89	LCDB	USART1 CLK	EIC EXTINT2	PEVC PAD EVT1	PARC PCDATA1		LCDCA SEG25	CATB SENSE25
81	G9	81	G9	PC26	90	LCDB	USART1 RXD	EIC EXTINT3	PEVC PAD EVT2	PARC PCDATA2	SCIF GCLK0	LCDCA SEG26	CATB SENSE26
82	F6	82	F6	PC27	91	LCDB	USART1 TXD	EIC EXTINT4	PEVC PAD EVT3	PARC PCDATA3	SCIF GCLK1	LCDCA SEG27	CATB SENSE27
83	G10	83	G10	PC28	92	LCDB	USART3 RXD	SPI MISO	GLOC IN4	PARC PCDATA4	SCIF GCLK2	LCDCA SEG28	CATB SENSE28
84	F7	84	F7	PC29	93	LCDB	USART3 TXD	SPI MOSI	GLOC IN5	PARC PCDATA5	SCIF GCLK3	LCDCA SEG29	CATB SENSE29
85	F8	85	F8	PC30	94	LCDB	USART3 RTS	SPI SCK	GLOC IN6	PARC PCDATA6	SCIF GCLK IN0	LCDCA SEG30	CATB SENSE30
86	F9	86	F9	PC31	95	LCDB	USART3 CLK	SPI NPCS0	GLOC OUT1	PARC PCDATA7	SCIF GCLK IN1	LCDCA SEG31	CATB SENSE31

Table 3-2. 64-pin GPIO Controller Function Multiplexing (Sheet 1 of 3)

ATSAM4LC	ATSAM4LS	Pin	GPIO	Supply	GPIO Functions							
QFP QFN	QFP QFN				A	B	C	D	E	F	G	
1	1	PA00	0	VDDIO								
2	2	PA01	1	VDDIO								
3	3	PA02	2	VDDIN	SCIF GCLK0	SPI NPCS0						CATB DIS
10	10	PA03	3	VDDIN		SPI MISO						

Table 3-2. 64-pin GPIO Controller Function Multiplexing (Sheet 2 of 3)

ATSAM4LC QFP QFN	ATSAM4LS QFP QFN	Pin	GPIO	Supply	GPIO Functions						
					A	B	C	D	E	F	G
15	15	PA04	4	VDDANA	ADCIFE AD0	USART0 CLK	EIC EXTINT2	GLOC IN1			CATB SENSE0
16	16	PA05	5	VDDANA	ADCIFE AD1	USART0 RXD	EIC EXTINT3	GLOC IN2	ADCIFE TRIGGER		CATB SENSE1
21	21	PA06	6	VDDANA	DACC VOUT	USART0 RTS	EIC EXTINT1	GLOC IN0	ACIFC ACAN0		CATB SENSE2
22	22	PA07	7	VDDANA	ADCIFE AD2	USART0 TXD	EIC EXTINT4	GLOC IN3	ACIFC ACAP0		CATB SENSE3
26	26	PA08	8	LCDA	USART0 RTS	TC0 A0	PEVC PAD EVT0	GLOC OUT0		LCDC SEG23	CATB SENSE4
29	29	PA09	9	LCDA	USART0 CTS	TC0 B0	PEVC PAD EVT1	PARC PCDATA0		LCDC COM3	CATB SENSE5
30	30	PA10	10	LCDA	USART0 CLK	TC0 A1	PEVC PAD EVT2	PARC PCDATA1		LCDC COM2	CATB SENSE6
31	31	PA11	11	LCDA	USART0 RXD	TC0 B1	PEVC PAD EVT3	PARC PCDATA2		LCDC COM1	CATB SENSE7
32	32	PA12	12	LCDA	USART0 TXD	TC0 A2		PARC PCDATA3		LCDC COM0	CATB DIS
40	40	PA13	13	LCDA	USART1 RTS	TC0 B2	SPI NPCS1	PARC PCDATA4		LCDC SEG5	CATB SENSE8
41	41	PA14	14	LCDA	USART1 CLK	TC0 CLK0	SPI NPCS2	PARC PCDATA5		LCDC SEG6	CATB SENSE9
42	42	PA15	15	LCDA	USART1 RXD	TC0 CLK1	SPI NPCS3	PARC PCDATA6		LCDC SEG7	CATB SENSE10
43	43	PA16	16	LCDA	USART1 TXD	TC0 CLK2	EIC EXTINT1	PARC PCDATA7		LCDC SEG8	CATB SENSE11
44	44	PA17	17	LCDA	USART2 RTS	ABDACB DAC0	EIC EXTINT2	PARC PCCK		LCDC SEG9	CATB SENSE12
49	49	PA18	18	LCDA	USART2 CLK	ABDACB DACN0	EIC EXTINT3	PARC PCEN1		LCDC SEG18	CATB SENSE13
50	50	PA19	19	LCDA	USART2 RXD	ABDACB DAC1	EIC EXTINT4	PARC PCEN2	SCIF GCLK0	LCDC SEG19	CATB SENSE14
51	51	PA20	20	LCDA	USART2 TXD	ABDACB DACN1	EIC EXTINT5	GLOC IN0	SCIF GCLK1	LCDC SEG20	CATB SENSE15
55	55	PA21	21	LCDC	SPI MISO	USART1 CTS	EIC EXTINT6	GLOC IN1	TWIM2 TWD	LCDC SEG34	CATB SENSE16
56	56	PA22	22	LCDC	SPI MOSI	USART2 CTS	EIC EXTINT7	GLOC IN2	TWIM2 TWCK	LCDC SEG35	CATB SENSE17
59	59	PA23	23	LCDC	SPI SCK	TWIMS0 TWD	EIC EXTINT8	GLOC IN3	SCIF GCLK IN0	LCDC SEG38	CATB DIS
60	60	PA24	24	LCDC	SPI NPCS0	TWIMS0 TWCK		GLOC OUT0	SCIF GCLK IN1	LCDC SEG39	CATB SENSE18
62	62	PA25	25	VDDIO	USBC DM	USART2 RXD					CATB SENSE19
63	63	PA26	26	VDDIO	USBC DP	USART2 TXD					CATB SENSE20

Table 3-2. 64-pin GPIO Controller Function Multiplexing (Sheet 3 of 3)

ATSAM4LC QFP QFN	ATSAM4LS QFP QFN	Pin	GPIO	Supply	GPIO Functions						
					A	B	C	D	E	F	G
	33	PA27	27	LCDA	SPI MISO	IISC ISCK	ABDACB DAC0	GLOC IN4	USART3 RTS		CATB SENSE0
	34	PA28	28	LCDA	SPI MOSI	IISC ISDI	ABDACB DACN0	GLOC IN5	USART3 CTS		CATB SENSE1
	35	PA29	29	LCDA	SPI SCK	IISC IWS	ABDACB DAC1	GLOC IN6	USART3 CLK		CATB SENSE2
	38	PA30	30	LCDA	SPI NPCS0	IISC ISDO	ABDACB DACN1	GLOC IN7	USART3 RXD		CATB SENSE3
	39	PA31	31	LCDA	SPI NPCS1	IISC IMCK	ABDACB CLK	GLOC OUT1	USART3 TXD		CATB DIS
11	11	PB00	32	VDDIN	TWIMS1 TWD	USART0 RXD					CATB SENSE21
12	12	PB01	33	VDDIN	TWIMS1 TWCK	USART0 TXD	EIC EXTINT0				CATB SENSE22
13	13	PB02	34	VDDANA	ADCIFE AD3	USART1 RTS	ABDACB DAC0	IISC ISCK	ACIFC ACBN0		CATB SENSE23
14	14	PB03	35	VDDANA	ADCIFE AD4	USART1 CLK	ABDACB DACN0	IISC ISDI	ACIFC ACBP0		CATB DIS
19	19	PB04	36	VDDANA	ADCIFE AD5	USART1 RXD	ABDACB DAC1	IISC ISDO	DACC EXT TRIG0		CATB SENSE24
20	20	PB05	37	VDDANA	ADCIFE AD6	USART1 TXD	ABDACB DACN1	IISC IMCK			CATB SENSE25
27	27	PB06	38	LCDA	USART3 RTS		GLOC IN4	IISC IWS		LCDCA SEG22	CATB SENSE26
28	28	PB07	39	LCDA	USART3 CTS		GLOC IN5	TC0 A0		LCDCA SEG21	CATB SENSE27
45	45	PB08	40	LCDA	USART3 CLK		GLOC IN6	TC0 B0		LCDCA SEG14	CATB SENSE28
46	46	PB09	41	LCDA	USART3 RXD	PEVC PAD EVT2	GLOC IN7	TC0 A1		LCDCA SEG15	CATB SENSE29
47	47	PB10	42	LCDA	USART3 TXD	PEVC PAD EVT3	GLOC OUT1	TC0 B1	SCIF GCLK0	LCDCA SEG16	CATB SENSE30
48	48	PB11	43	LCDA	USART0 CTS	SPI NPCS2		TC0 A2	SCIF GCLK1	LCDCA SEG17	CATB SENSE31
53	53	PB12	44	LCDC	USART0 RTS	SPI NPCS3	PEVC PAD EVT0	TC0 B2	SCIF GCLK2	LCDCA SEG32	CATB DIS
54	54	PB13	45	LCDC	USART0 CLK	SPI NPCS1	PEVC PAD EVT1	TC0 CLK0	SCIF GCLK3	LCDCA SEG33	CATB SENSE0
57	57	PB14	46	LCDC	USART0 RXD	SPI MISO	TWIM3 TWD	TC0 CLK1	SCIF GCLK IN0	LCDCA SEG36	CATB SENSE1
58	58	PB15	47	LCDC	USART0 TXD	SPI MOSI	TWIM3 TWCK	TC0 CLK2	SCIF GCLK IN1	LCDCA SEG37	CATB SENSE2

Table 3-3. 64-pin GPIO Controller Function Multiplexing for WLCSP package (Sheet 1 of 3)

WLCSP	WLCSP	Pin	GPIO	Supply	GPIO Functions							
					A	B	C	D	E	F	G	
G4	G4	PA00	0	VDDIO								
G5	G5	PA01	1	VDDIO								
F3	F3	PA02	2	VDDIN	SCIF GCLK0	SPI NPCS0						CATB DIS
E2	E2	PA03	3	VDDIN		SPI MISO						
D3	D3	PA04	4	VDDANA	ADCIFE AD0	USART0 CLK	EIC EXTINT2	GLOC IN1				CATB SENSE0
C3	C3	PA05	5	VDDANA	ADCIFE AD1	USART0 RXD	EIC EXTINT3	GLOC IN2	ADCIFE TRIGGER			CATB SENSE1
C4	C4	PA06	6	VDDANA	DACC VOUT	USART0 RTS	EIC EXTINT1	GLOC IN0	ACIFC ACAN0			CATB SENSE2
C5	C5	PA07	7	VDDANA	ADCIFE AD2	USART0 TXD	EIC EXTINT4	GLOC IN3	ACIFC ACAP0			CATB SENSE3
B4	B4	PA08	8	LCDA	USART0 RTS	TC0 A0	PEVC PAD EVT0	GLOC OUT0		LCDC SEG23		CATB SENSE4
A5	A5	PA09	9	LCDA	USART0 CTS	TC0 B0	PEVC PAD EVT1	PARC PCDATA0		LCDC COM3		CATB SENSE5
B6	B6	PA10	10	LCDA	USART0 CLK	TC0 A1	PEVC PAD EVT2	PARC PCDATA1		LCDC COM2		CATB SENSE6
B7	B7	PA11	11	LCDA	USART0 RXD	TC0 B1	PEVC PAD EVT3	PARC PCDATA2		LCDC COM1		CATB SENSE7
A8	A8	PA12	12	LCDA	USART0 TXD	TC0 A2		PARC PCDATA3		LCDC COM0		CATB DIS
C7	C7	PA13	13	LCDA	USART1 RTS	TC0 B2	SPI NPCS1	PARC PCDATA4		LCDC SEG5		CATB SENSE8
D7	D7	PA14	14	LCDA	USART1 CLK	TC0 CLK0	SPI NPCS2	PARC PCDATA5		LCDC SEG6		CATB SENSE9
E7	E7	PA15	15	LCDA	USART1 RXD	TC0 CLK1	SPI NPCS3	PARC PCDATA6		LCDC SEG7		CATB SENSE10
F7	F7	PA16	16	LCDA	USART1 TXD	TC0 CLK2	EIC EXTINT1	PARC PCDATA7		LCDC SEG8		CATB SENSE11
G8	G8	PA17	17	LCDA	USART2 RTS	ABDACB DAC0	EIC EXTINT2	PARC PCCK		LCDC SEG9		CATB SENSE12
G7	G7	PA18	18	LCDA	USART2 CLK	ABDACB DACN0	EIC EXTINT3	PARC PCEN1		LCDC SEG18		CATB SENSE13
G6	G6	PA19	19	LCDA	USART2 RXD	ABDACB DAC1	EIC EXTINT4	PARC PCEN2	SCIF GCLK0	LCDC SEG19		CATB SENSE14
H7	H7	PA20	20	LCDA	USART2 TXD	ABDACB DACN1	EIC EXTINT5	GLOC IN0	SCIF GCLK1	LCDC SEG20		CATB SENSE15
H5	H5	PA21	21	LCDC	SPI MISO	USART1 CTS	EIC EXTINT6	GLOC IN1	TWIM2 TWD	LCDC SEG34		CATB SENSE16
F5	F5	PA22	22	LCDC	SPI MOSI	USART2 CTS	EIC EXTINT7	GLOC IN2	TWIM2 TWCK	LCDC SEG35		CATB SENSE17