



Chipsmall Limited consists of a professional team with an average of over 10 year of expertise in the distribution of electronic components. Based in Hongkong, we have already established firm and mutual-benefit business relationships with customers from,Europe,America and south Asia,supplying obsolete and hard-to-find components to meet their specific needs.

With the principle of “Quality Parts,Customers Priority,Honest Operation,and Considerate Service”,our business mainly focus on the distribution of electronic components. Line cards we deal with include Microchip,ALPS,ROHM,Xilinx,Pulse,ON,Everlight and Freescale. Main products comprise IC,Modules,Potentiometer,IC Socket,Relay,Connector.Our parts cover such applications as commercial,industrial, and automotives areas.

We are looking forward to setting up business relationship with you and hope to provide you with the best service and solution. Let us make a better world for our industry!



Contact us

Tel: +86-755-8981 8866 Fax: +86-755-8427 6832

Email & Skype: info@chipsmall.com Web: www.chipsmall.com

Address: A1208, Overseas Decoration Building, #122 Zhenhua RD., Futian, Shenzhen, China



ATtiny817 QTouch Moisture Demo User Guide

USER GUIDE

Description

The Atmel® ATtiny817 QTouch® Moisture Demo Kit demonstrates the high performance capacitive touch support of the Peripheral Touch Controller (PTC) while achieving best-in-class conducted immunity and moisture tolerance. It has driven shield for better noise immunity and moisture tolerance. It implements a robust solution that allows customers to easily incorporate the Atmel QTouch technology into designs that require a high level of moisture tolerance.

Features

- Four self capacitance buttons
- Six LEDs to display touch and power status
- On-board Embedded Debugger module for programming/debugging



Table of Contents

Description.....	1
Features.....	1
1. Overview.....	3
2. Hardware Description.....	4
3. Pin Configuration.....	5
3.1. Self Capacitance.....	5
3.2. Indication.....	5
4. Unit Assembly.....	6
5. Embedded Debugger (EDBG).....	7
6. Powering Up the Kit.....	9
6.1. Jumper Settings.....	9
7. Board Operation.....	11
8. Schematic.....	12
9. PCB Design.....	14
10. Bill of Materials.....	15
11. Reference.....	17
12. Revision History.....	18

1. Overview

This document describes the ATtiny817 QTouch Moisture Demo kit. The kit demonstrates self capacitance sensors running on Atmel ATtiny817 microcontroller. The associated package for the ATtiny817 QTouch Moisture Demo kit contains schematics, Gerber, BoM, and firmware.

The kit consists of a base board and a front panel. The front panel is glued to the baseboard.

The kit is designed to be used as a standalone unit to evaluate the noise immunity and moisture tolerance performance.

Figure 1-1. Demo Kit



2. Hardware Description

Figure 2-1. Block Diagram

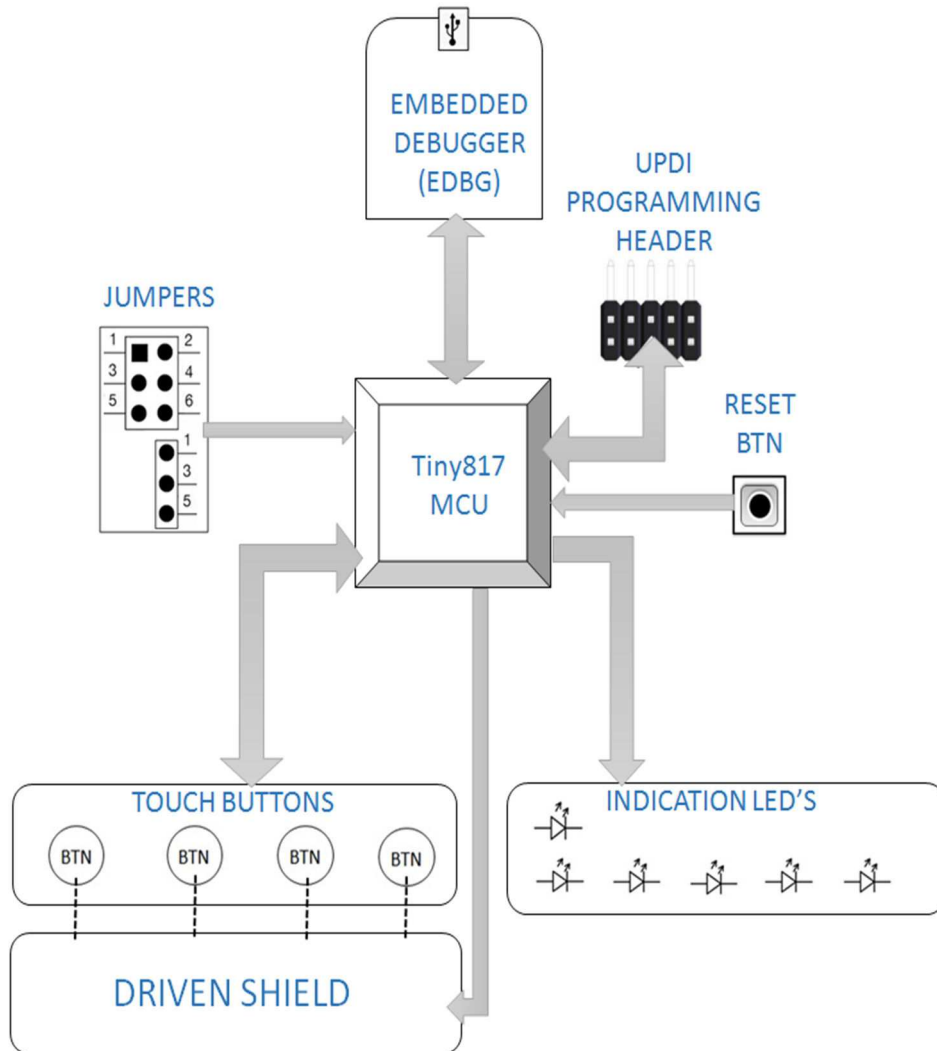

3. Pin Configuration

3.1. Self Capacitance

The demo kit has four touch buttons, which are based on self-capacitance technology. There are four Y-lines used. The front panel is pasted directly onto the PCB.

Table 3-1. Pin Configuration of the Self Capacitance Sensors

Functionality	MCU pin	MCU pin name
Y0	5	PA4
Y1	6	PA5
Y2	7	PA6
Y3	8	PA7

3.2. Indication

This demo kit has six LEDs to indicate the status, out of which four LEDs are for touch detection, one for power status, and one is user LED.

Table 3-2. Pin Configuration of LEDs

Functionality	MCU pin	MCU pin name
POWER ON LED	11	PB5
USER LED	13	PB3
QTOUCH LED1	9	PB7
QTOUCH LED2	10	PB6
QTOUCH LED3	2	PA3
QTOUCH LED4	21	PC4

4. Unit Assembly

There are two separate units for the demo kit:

- Acrylic front panel
- Base PCB

Figure 4-1. Board Stack Up



5. Embedded Debugger (EDBG)

The demo kit features an on-board Embedded Debugger (EDBG) module. This can be used for programming and debugging the firmware using Atmel Studio.

Figure 5-1. EDBG Module

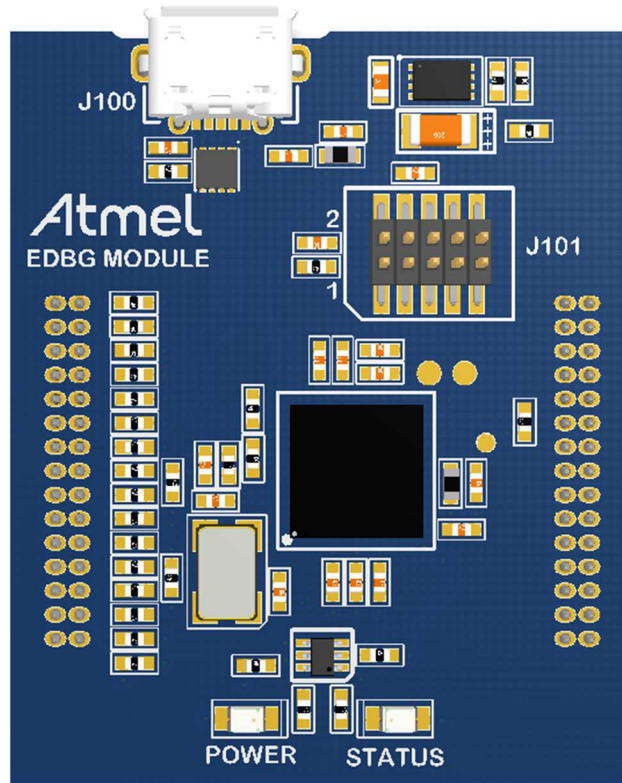

EDBG is mounted on the kit as a separate module. By using the EDBG the user can program the QTouch Moisture Demo kit. The EDBG has been pre-configured to support an ATtiny817 device using UPDI interface for programming and debugging.

Figure 5-2. Connecting with EDBG for Programming using Atmel Studio

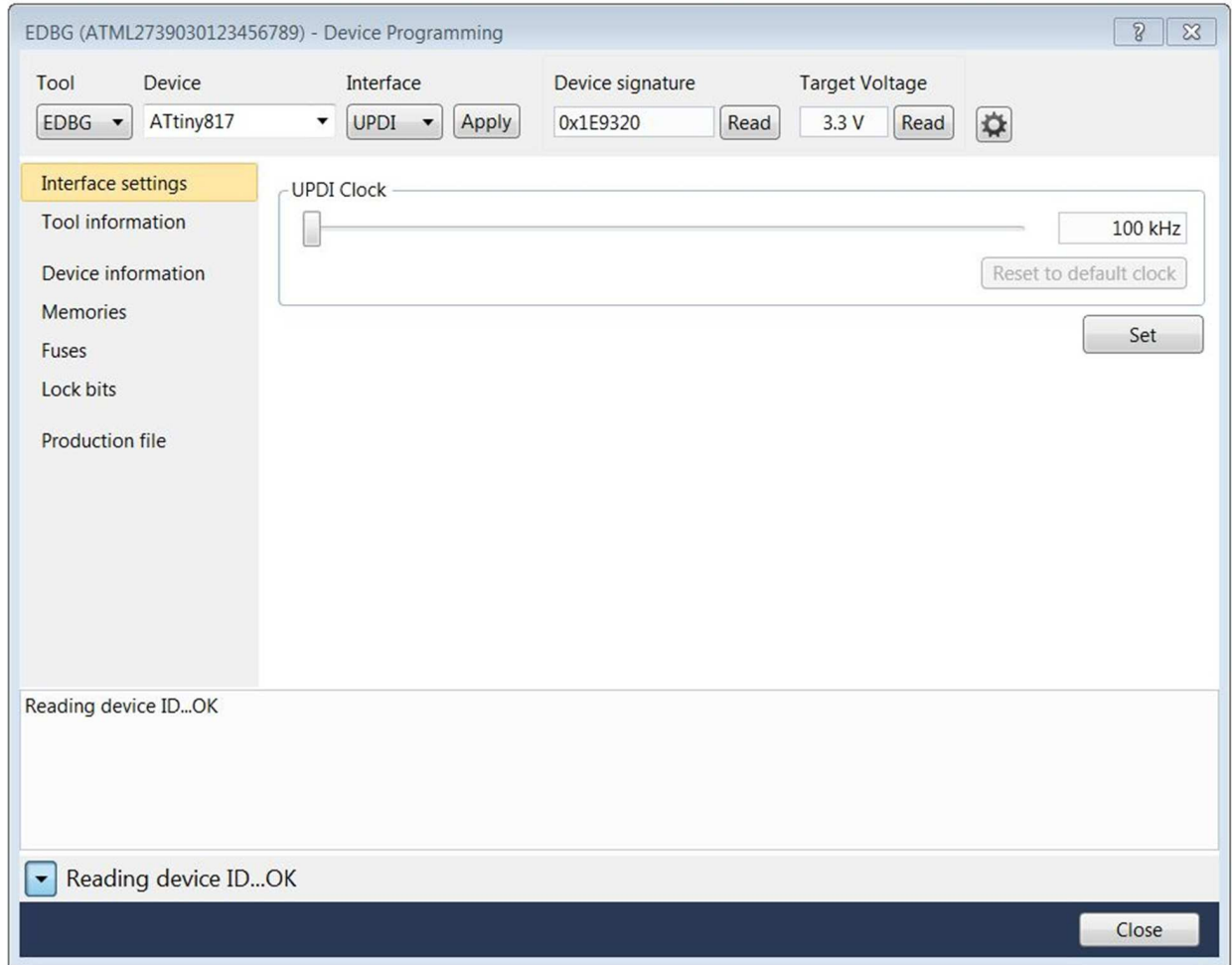

6. Powering Up the Kit

The kit should be powered using USB connected to the EDBG module only. There are multiple components in the kit which can handle different voltage ratings. Safe operating voltage of ATtiny817 MCU is between 1.8V and 5V. Power supplied to the ATtiny817 MCU can be changed by changing the jumper settings.

6.1. Jumper Settings

We have four different jumper settings for powering the ATtiny817 MCU.

1. 5V

Figure 6-1. Jumper Setting for 5V

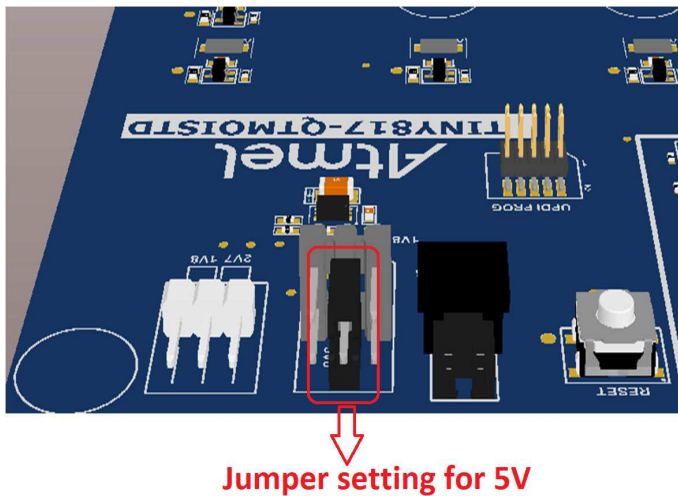

2. 3.3V

Figure 6-2. Jumper Setting for 3.3V

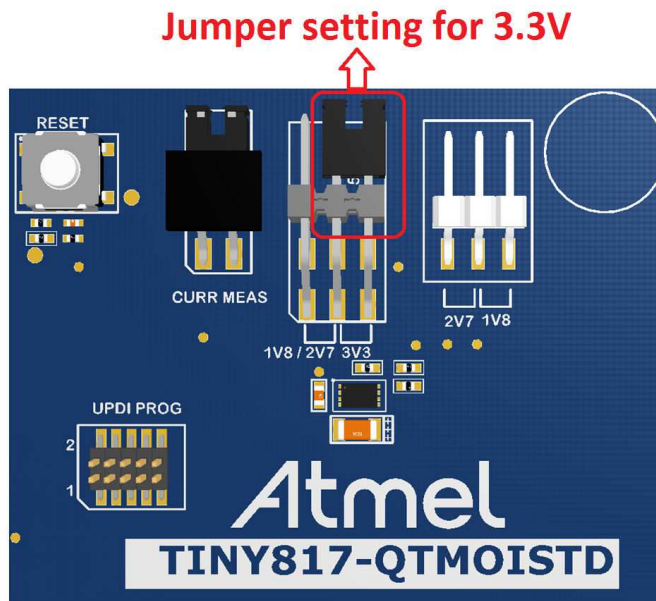

3. 2.7V

Figure 6-3. Jumper Settings for 2.7V

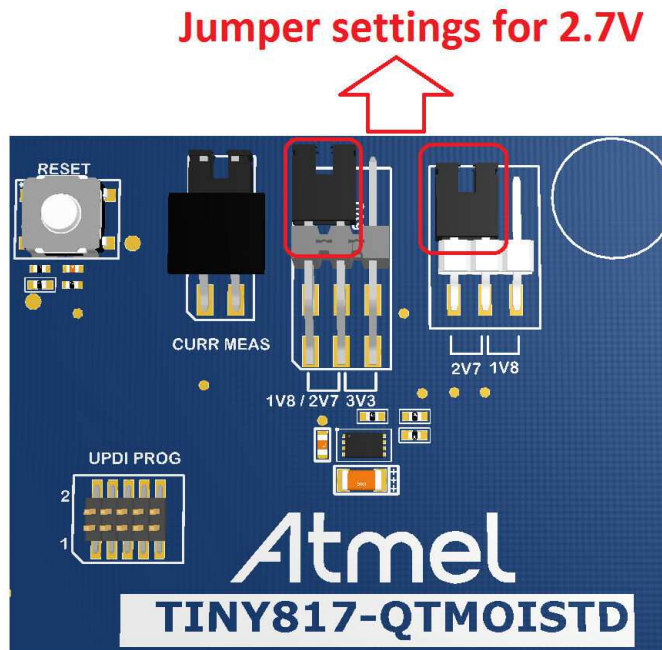

4. 1.8V

Figure 6-4. Jumper Settings for 1.8V

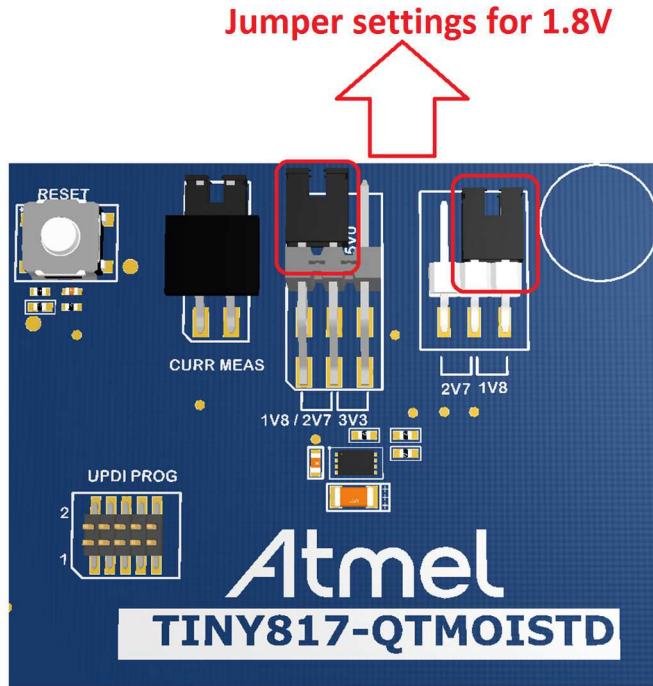

However, the LEDs are driven at +3.3V by default to ensure optimum brightness. +3.3V for LEDs and other components are supplied from the regulator on the EDBG module.

7. Board Operation

Figure 7-1. Layout of Sensors on the Kit

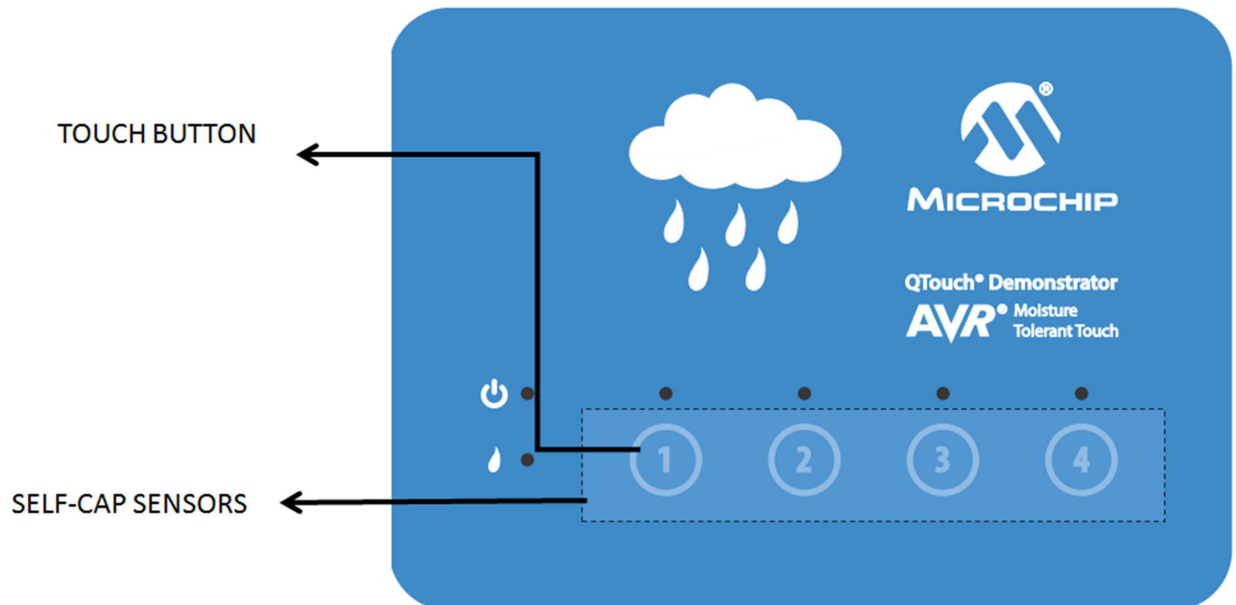

There are four individual touch button sensors named 1, 2, 3, and 4. When touching each touch button, their corresponding LEDs start glowing. Also the power LED will remain glowing to indicate the ON state of the touch panel.

8. Schematic

Figure 8-1. MCU and Sensor Configuration Section

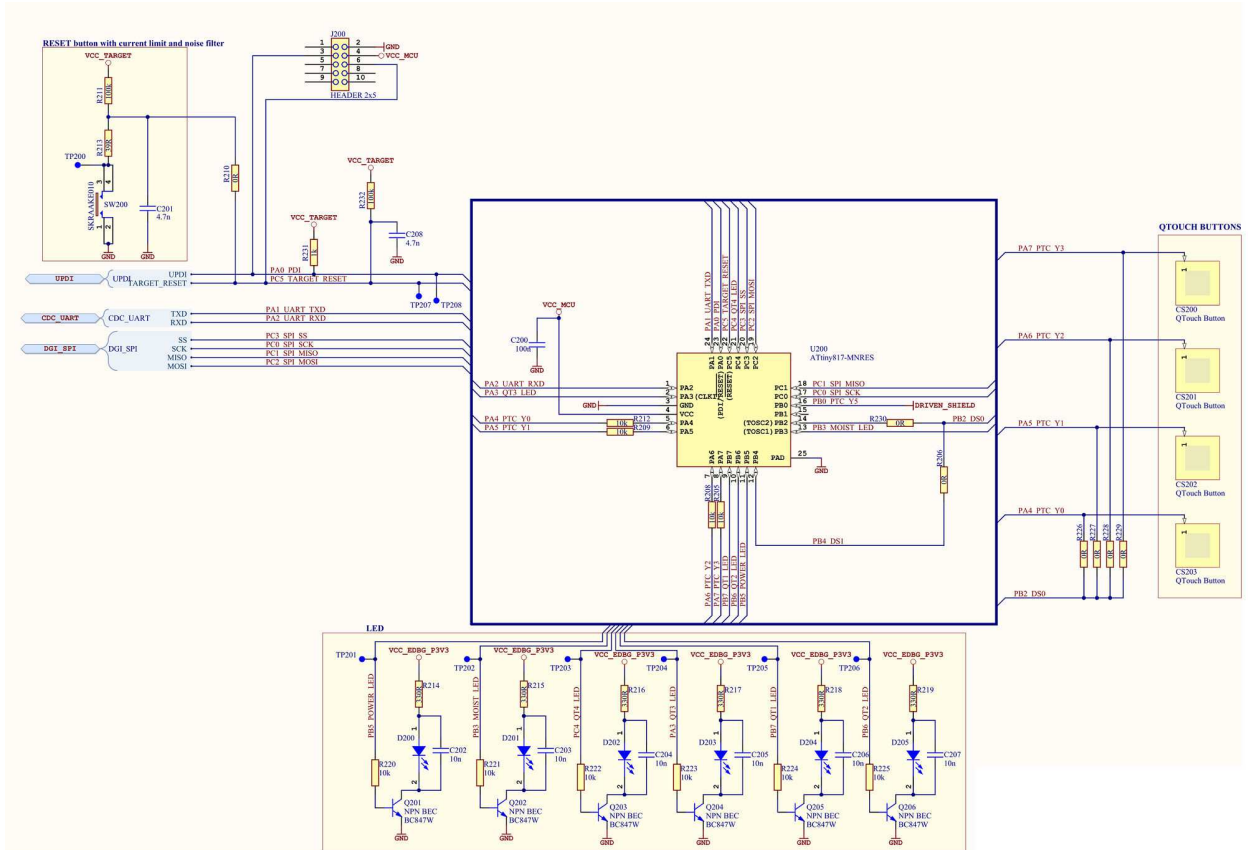

Figure 8-2. EDBG Level Translators

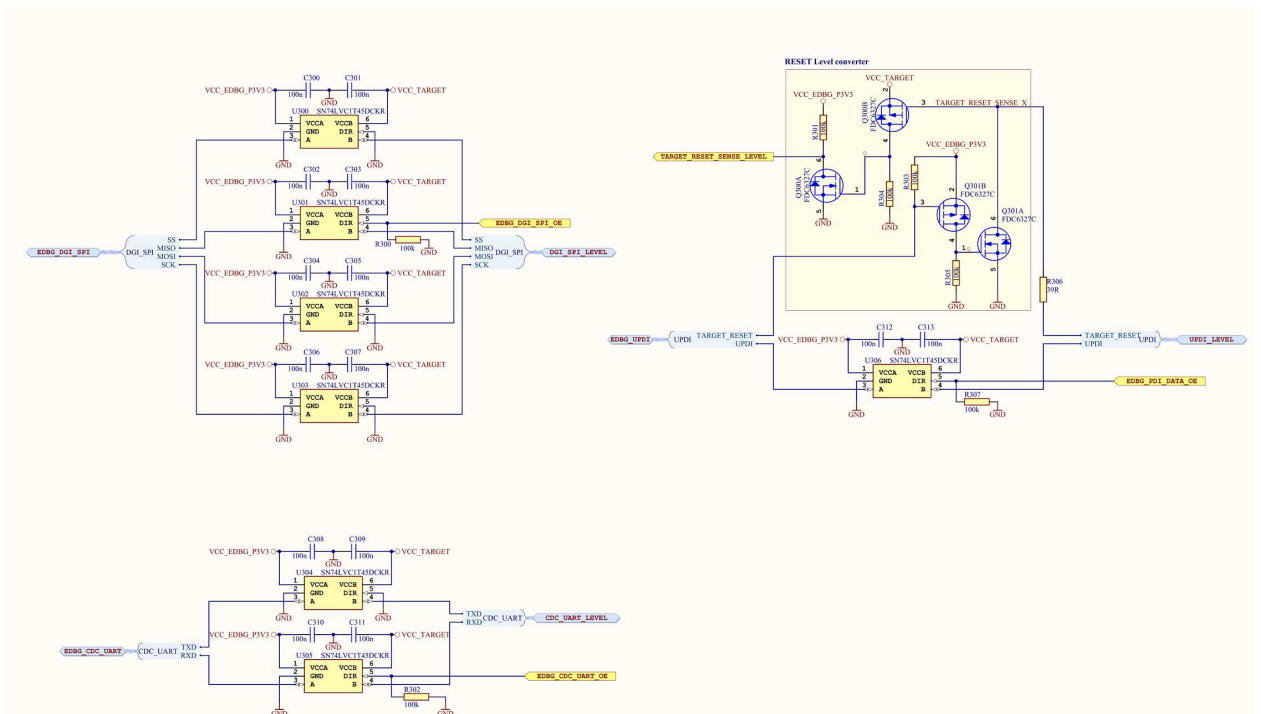
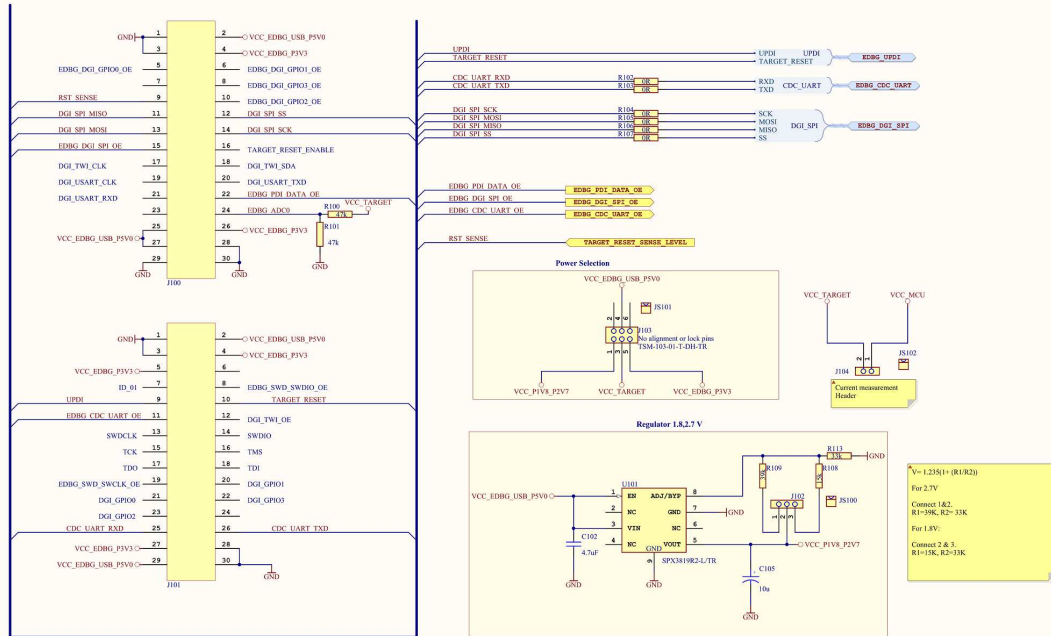

Figure 8-3. EDBG Headers and Connectors



9. PCB Design

Figure 9-1. Top Layer

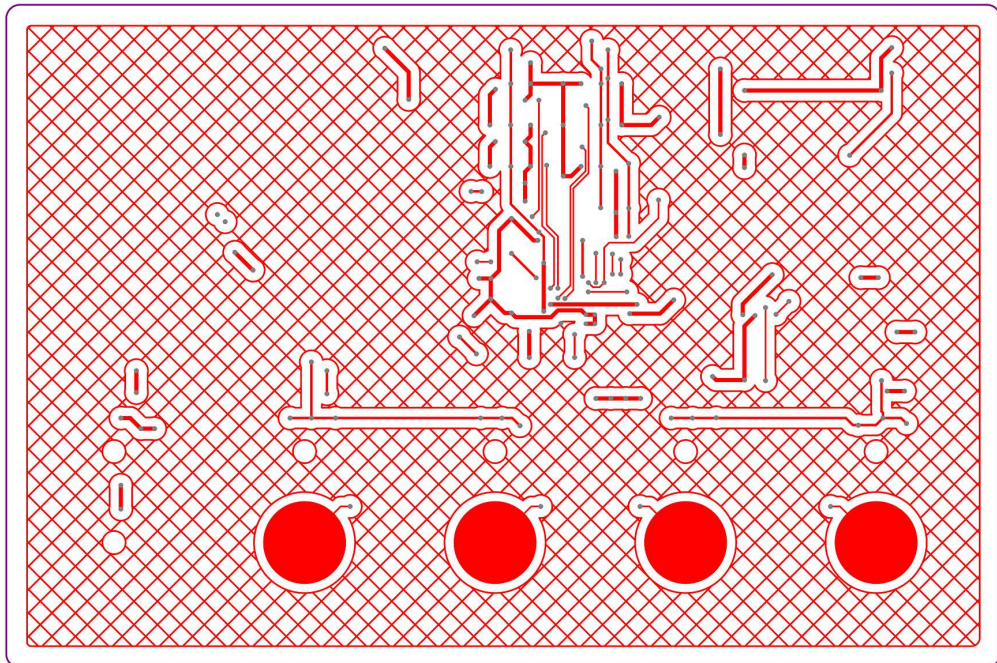
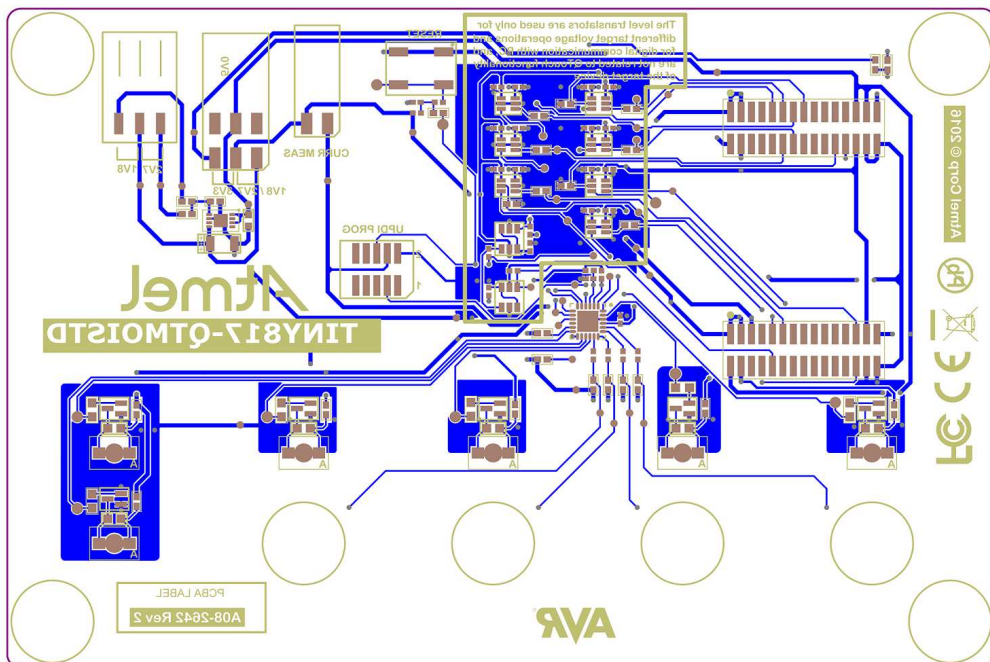

Figure 9-2. Bottom Layer



10. Bill of Materials

Table 10-1. Top Level Bill of Materials

Component	Quantity
Acrylic Front Panel	1
TINY817 QTOUCH MOISTURE DEMO BASE BOARD-PCBA	1
Atmel EDBG-PCBA	1
(Rubber Feet) Bump-on	4

Table 10-2. Bill of Material for the Base Board

Designator	Quantity	Value	Description
C102	1	4.7 μ F	SMD capacitor 0603
C105	1	10 μ F	SMD tantalum capacitor, ESR = 1.7, 3216-18 (EIA) 1206,
C200, C300, C301, C302, C303, C304, C305, C306, C307, C308, C309, C310, C311, C312, C313	15	100nF	SMD capacitor 0402
C201, C208	2	4.7nF	SMD capacitor 0402
C202, C203, C204, C205, C206, C207	6	10nF	SMD capacitor 0603
D200, D201, D202, D203, D204, D205	6	LTW-C230DS	Reverse mount SMD white LED 180-450mcd@20mA
J100, J101	2	2x15 pin header, 1.27mm pitch, Straight, SMD	2x15 pin header, 1.27mm pitch, straight, SMD
J102	1	1x3 pin header, Right angle, 2.54mm pitch SMD	1x3 pin header, right angle, 2.54mm pitch SMD
J103	1	TSM-103-01-T-DH-TR	2x3 pin header, right angle, 2.54mm pitch SMD, tin
J104	1	Horizontal HEADER 1x2	1x2 horizontal pin header, 2.54mm pitch, SMD
J200	1	20021121-00010C4LF	2x5 pin header, 1.27mm pitch, SMD
JS100, JS101, JS102	3	SNT-100-BK-G	Jumper cap for 2.54mm pin-header

Designator	Quantity	Value	Description
Q201, Q202, Q203, Q204, Q205, Q206	6	BC847W	NPN SMD small signal BJT transistor
Q300, Q301	2	FDC6327C	Dual N/P-ch MOSFET, 20V, 2.7A/-1.9A cont, 8A/-8A pulse, RDS(ON)<0.08/0.17Ω@VGS=4.5V, VGS(th)<1.5/-1.5V, SSOT6
R100, R101	2	47kΩ	Thick film resistor, SMD 0402, 1/16W, 1%
R102, R103, R104, R105, R106, R107, R206, R210, R226, R227, R228, R229, R230	13	0Ω	Resistor 0.0Ω, 1/16W, 0402 SMD
R108	1	15kΩ	SMD resistor 0402
R109	1	39kΩ	SMD resistor 0402
R113	1	33kΩ	SMD resistor 0402
R205, R208, R209, R212	4	10kΩ	SMD resistor 0402
R211, R232, R300, R301, R302, R303, R304, R305, R307	9	100kΩ	SMD resistor 0402
R213, R306	2	39Ω	SMD resistor 0402
R214, R215, R216, R217, R218, R219	6	330Ω	SMD resistor 0402
R220, R221, R222, R223, R224, R225	6	10kΩ	SMD resistor 0603
R231	1	1kΩ	SMD resistor 0402
SW200	1	SKRAAKE010	6.2x6.2mm SMD tact switch
U101	1	SPX3819R2-L/TR	500mA LDO, ADJ, low noise, 8-DFN package
U200	1	ATtiny817-MFR	Atmel 8-bit RISC MCU, engineering sample
U300, U301, U302, U303, U304, U305, U306	7	SN74LVC1T45DCKR	Single-bit dual-supply bus transceiver with configurable voltage translation and 3-state outputs

11. Reference

[1]. QTAN0079: Buttons, Sliders, and Wheels, Touch Sensor Design Guide - <http://www.atmel.com/Images/doc10752.pdf>.

[2]. AT09363: PTC Robustness Design Guide, application note - http://www.atmel.com/images/atmel-42360-ptc-robustness-design-guide_applicationnote_at09363.pdf.

[3]. QTouch Modular Library Peripheral Touch Controller, User Guide - http://www.atmel.com/images/Atmel-42805-QTouch-Modular-Library-Peripheral-Touch-Controller_User-Guide.pdf

12. Revision History

Doc Rev.	Date	Comments
42798A	11/2016	Initial document release

Atmel®, Atmel logo and combinations thereof, Enabling Unlimited Possibilities®, AVR®, QTouch®, and others are registered trademarks or trademarks of Atmel Corporation in U.S. and other countries. Other terms and product names may be trademarks of others.

DISCLAIMER: The information in this document is provided in connection with Atmel products. No license, express or implied, by estoppel or otherwise, to any intellectual property right is granted by this document or in connection with the sale of Atmel products. EXCEPT AS SET FORTH IN THE ATMEL TERMS AND CONDITIONS OF SALES LOCATED ON THE ATMEL WEBSITE, ATMEL ASSUMES NO LIABILITY WHATSOEVER AND DISCLAIMS ANY EXPRESS, IMPLIED OR STATUTORY WARRANTY RELATING TO ITS PRODUCTS INCLUDING, BUT NOT LIMITED TO, THE IMPLIED WARRANTY OF MERCHANTABILITY, FITNESS FOR A PARTICULAR PURPOSE, OR NON-INFRINGEMENT. IN NO EVENT SHALL ATMEL BE LIABLE FOR ANY DIRECT, INDIRECT, CONSEQUENTIAL, PUNITIVE, SPECIAL OR INCIDENTAL DAMAGES (INCLUDING, WITHOUT LIMITATION, DAMAGES FOR LOSS AND PROFITS, BUSINESS INTERRUPTION, OR LOSS OF INFORMATION) ARISING OUT OF THE USE OR INABILITY TO USE THIS DOCUMENT, EVEN IF ATMEL HAS BEEN ADVISED OF THE POSSIBILITY OF SUCH DAMAGES. Atmel makes no representations or warranties with respect to the accuracy or completeness of the contents of this document and reserves the right to make changes to specifications and products descriptions at any time without notice. Atmel does not make any commitment to update the information contained herein. Unless specifically provided otherwise, Atmel products are not suitable for, and shall not be used in, automotive applications. Atmel products are not intended, authorized, or warranted for use as components in applications intended to support or sustain life.

SAFETY-CRITICAL, MILITARY, AND AUTOMOTIVE APPLICATIONS DISCLAIMER: Atmel products are not designed for and will not be used in connection with any applications where the failure of such products would reasonably be expected to result in significant personal injury or death ("Safety-Critical Applications") without an Atmel officer's specific written consent. Safety-Critical Applications include, without limitation, life support devices and systems, equipment or systems for the operation of nuclear facilities and weapons systems. Atmel products are not designed nor intended for use in military or aerospace applications or environments unless specifically designated by Atmel as military-grade. Atmel products are not designed nor intended for use in automotive applications unless specifically designated by Atmel as automotive-grade.