



Chipsmall Limited consists of a professional team with an average of over 10 year of expertise in the distribution of electronic components. Based in Hongkong, we have already established firm and mutual-benefit business relationships with customers from,Europe,America and south Asia,supplying obsolete and hard-to-find components to meet their specific needs.

With the principle of “Quality Parts,Customers Priority,Honest Operation,and Considerate Service”,our business mainly focus on the distribution of electronic components. Line cards we deal with include Microchip,ALPS,ROHM,Xilinx,Pulse,ON,Everlight and Freescale. Main products comprise IC,Modules,Potentiometer,IC Socket,Relay,Connector.Our parts cover such applications as commercial,industrial, and automotives areas.

We are looking forward to setting up business relationship with you and hope to provide you with the best service and solution. Let us make a better world for our industry!



## Contact us

Tel: +86-755-8981 8866 Fax: +86-755-8427 6832

Email & Skype: info@chipsmall.com Web: www.chipsmall.com

Address: A1208, Overseas Decoration Building, #122 Zhenhua RD., Futian, Shenzhen, China



### CURRENT SENSE HIGH SIDE SWITCH

#### Features

- Suitable for 24V systems
- Over current shutdown
- Over temperature shutdown
- Current sensing
- Active clamp
- Reverse circulation immunization
- Optimized Turn On/Off for EMI
- Reverse battery protection (Mosfet on)

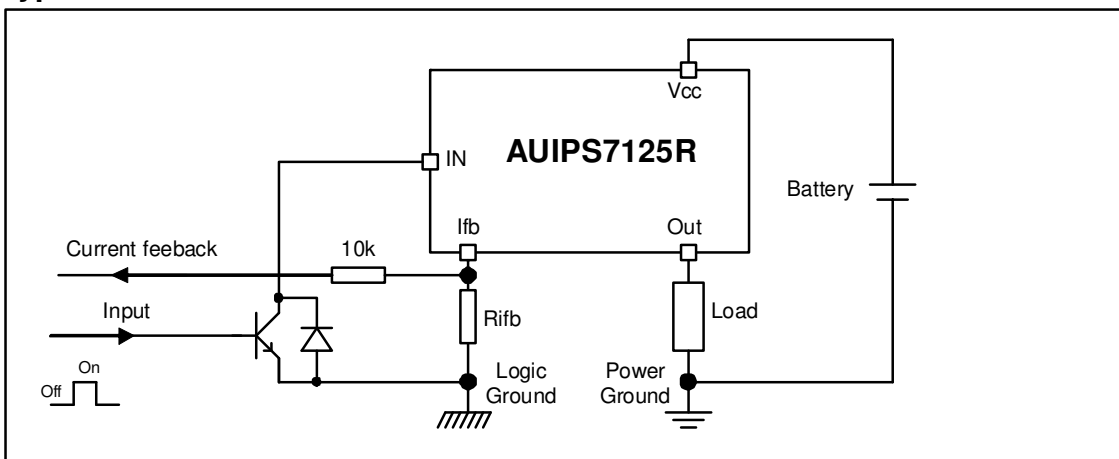
#### Applications

- 75W Filament lamp
- Solenoid
- 24V loads for trucks

#### Description

The AUIPS7125R is a fully protected five terminal high side switch specifically designed for driving lamp. It features current sensing, over-current, over-temperature, ESD protection and drain to source active clamp. When the input voltage  $V_{cc} - V_{in}$  is higher than the specified threshold, the output power Mosfet is turned on. When the  $V_{cc} - V_{in}$  is lower than the specified  $V_{il}$  threshold, the output Mosfet is turned off. The  $I_{fb}$  pin is used for current sensing. The over-current shutdown is higher than inrush current of the lamp.

#### Typical Connection



#### Product Summary

$R_{ds(on)}$	30m $\Omega$ max.
$V_{clamp}$	65V
Current shutdown	50A min.

#### Packages



DPAK

**Qualification Information†**

<b>Qualification Level</b>		Automotive (per AEC-Q100††)
		Comments: This family of ICs has passed an Automotive qualification. IR's Industrial and Consumer qualification level is granted by extension of the higher Automotive level.
<b>Moisture Sensitivity Level</b>		<p style="text-align: center;">DPAK-5L</p> <p style="text-align: right;">MSL1, 260°C (per IPC/JEDEC J-STD-020)</p>
<b>ESD</b>	Machine Model	Class M2 (200 V) (per AEC-Q100-003)
	Human Body Model	Class H1C (1500 V) (per AEC-Q100-002)
	Charged Device Model	Class C5 (1000 V) (per AEC-Q100-011)
<b>IC Latch-Up Test</b>		Class II, Level A (per AEC-Q100-004)
<b>RoHS Compliant</b>		Yes

† Qualification standards can be found at International Rectifier's web site <http://www.irf.com/>

†† Exceptions (if any) to AEC-Q100 requirements are noted in the qualification report.

## Absolute Maximum Ratings

Absolute maximum ratings indicate sustained limits beyond which damage to the device may occur. (T<sub>j</sub>= -40°C..150°C, V<sub>cc</sub>=6..50V unless otherwise specified).

Symbol	Parameter	Min.	Max.	Units
V <sub>out</sub>	Maximum output voltage	V <sub>cc</sub> -60	V <sub>cc</sub> +0.3	V
I <sub>rev</sub>	Maximum reverse pulsed current (t=100µs) see page 8	—	60	A
I <sub>sd cont.</sub>	Maximum diode continuous current T <sub>ambient</sub> =25°C, R <sub>th</sub> =70°C/W	—	2.5	
V <sub>cc-Vin max.</sub>	Maximum V <sub>cc</sub> voltage	-32	60	V
I <sub>fb, max.</sub>	Maximum feedback current	-50	10	mA
V <sub>cc sc</sub>	Maximum V <sub>cc</sub> voltage with short circuit protection see page 8	—	50	V
P <sub>d</sub>	Maximum power dissipation (internally limited by thermal protection) R <sub>th</sub> =50°C/W DPack 6cm <sup>2</sup> footprint	—	2.5	W
T <sub>j max.</sub>	Max. storage & operating junction temperature	-40	150	°C

## Thermal Characteristics

Symbol	Parameter	Typ.	Max.	Units
R <sub>th1</sub>	Thermal resistance junction to ambient DPak Std footprint	70	—	°C/W
R <sub>th2</sub>	Thermal resistance junction to ambient Dpak 6cm <sup>2</sup> footprint	50	—	
R <sub>th3</sub>	Thermal resistance junction to case Dpak	2	—	

## Recommended Operating Conditions

These values are given for a quick design.

Symbol	Parameter	Min.	Max.	Units
I <sub>out</sub>	Continuous output current, T <sub>ambient</sub> =85°C, T <sub>j</sub> =125°C R <sub>th</sub> =50°C/W, Dpak 6cm <sup>2</sup> footprint	—	3.8	A
R <sub>ifb</sub>	I <sub>fb</sub> resistor	1.5	—	kΩ

## Static Electrical Characteristics

$T_j = -40^{\circ}\text{C}..150^{\circ}\text{C}$ ,  $V_{cc} = 6-50\text{V}$  (unless otherwise specified)

Symbol	Parameter	Min.	Typ.	Max.	Units	Test Conditions
Vcc op.	Operating voltage range	6	—	60	V	
Rds(on)	ON state resistance $T_j = 25^{\circ}\text{C}$	—	24	30	m $\Omega$	Ids=2A
	ON state resistance $T_j = 150^{\circ}\text{C}$ (2)	—	45	55		
Icc off	Supply leakage current	—	2	4	$\mu\text{A}$	Vin=Vcc=28V, Vifb=Vgnd Vout=Vgnd, $T_j = 25^{\circ}\text{C}$
Iout off	Output leakage current	—	2	4		
Iin on	Input current when device on	1	3.5	6	mA	Vcc-Vin=28V, $T_j = 25^{\circ}\text{C}$
V clamp1	Vcc to Vout clamp voltage 1	60	64	—	V	Id=10mA
V clamp2	Vcc to Vout clamp voltage 2	60	65	72		Id=20A see fig. 2
Vih(1)	High level Input threshold voltage	—	3.5	5.9		Id=10mA
Vil(1)	Low level Input threshold voltage	1.5	3.2	—		
Rds(on) rev	Reverse On state resistance $T_j = 25^{\circ}\text{C}$	—	25	40	m $\Omega$	I <sub>sd</sub> =2A
Vf	Forward body diode voltage $T_j = 25^{\circ}\text{C}$	—	0.75	0.85	V	If=3A
	Forward body diode voltage $T_j = 125^{\circ}\text{C}$	—	0.62	0.7		
Rin	Input resistor	180	250	350	$\Omega$	

(1) Input thresholds are measured directly between the input pin and the tab.

## Switching Electrical Characteristics

$V_{cc} = 28\text{V}$ , Resistive load=6.8 $\Omega$ ,  $T_j = -40^{\circ}\text{C}..150^{\circ}\text{C}$

Symbol	Parameter	Min.	Typ.	Max.	Units	Test Conditions
tdon	Turn on delay time	5	15	30	$\mu\text{s}$	See fig. 1
tr	Rise time from 20% to 80% of Vcc	5	10	30		
tdoff	Turn off delay time	35	75	120	$\mu\text{s}$	
tf	Fall time from 80% to 20% of Vcc	6	15	30		

## Protection Characteristics

$T_j = -40^{\circ}\text{C}..150^{\circ}\text{C}$ ,  $V_{cc} = 6-50\text{V}$  (unless otherwise specified)

Symbol	Parameter	Min.	Typ.	Max.	Units	Test Conditions
Tsd	Over temperature threshold(2)	150	165	—	$^{\circ}\text{C}$	See fig. 3 and fig. 11
I <sub>sd</sub>	Over-current shutdown	50	60	85	A	See fig. 3 and page 7
I <sub>fault</sub>	I <sub>fb</sub> after an over-current or an over-temperature (latched)	2.2	3	5	mA	See fig. 3

## Current Sensing Characteristics

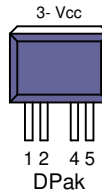
$T_j = -40^{\circ}\text{C}..150^{\circ}\text{C}$ ,  $V_{cc} = 6-50\text{V}$  (unless otherwise specified). Specified 500 $\mu\text{s}$  after the turn on.  $V_{cc} - V_{ifb} > 4\text{V}$

Symbol	Parameter	Min.	Typ.	Max.	Units	Test Conditions
Ratio	I <sub>load</sub> / I <sub>fb</sub> current ratio	7050	8500	9950		I <sub>load</sub> < 14A
Ratio <sub>TC</sub>	I <sub>load</sub> / I <sub>fb</sub> variation over temperature(2)	-5%	0	+5	%	$T_j = -40^{\circ}\text{C}$ to $+150^{\circ}\text{C}$
I <sub>offset</sub>	Load current offset	-0.06	0	0.06	A	I <sub>out</sub> < 14A
I <sub>fb</sub> leakage	I <sub>fb</sub> leakage current	0	1	10	$\mu\text{A}$	I <sub>out</sub> = 0A

(2) Guaranteed by design

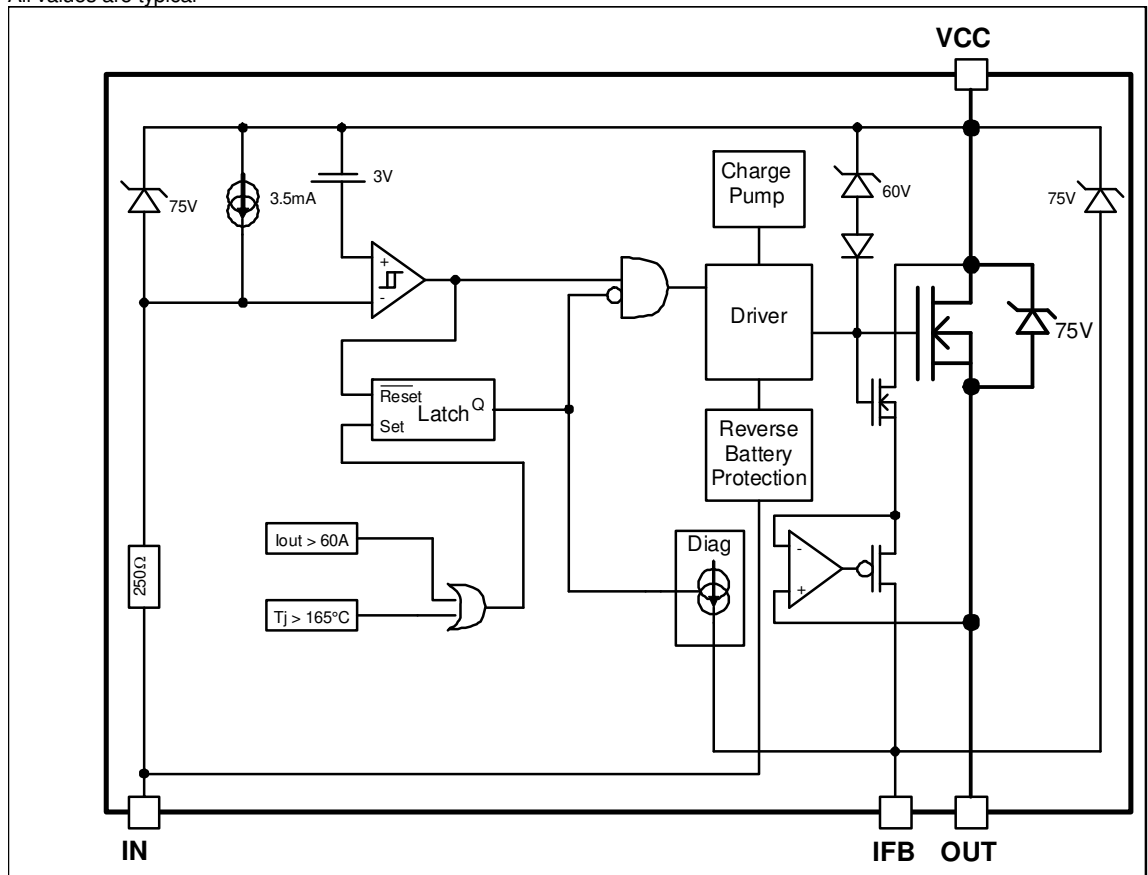
## Lead Assignments

- 1- NC
- 2- In
- 3- Vcc
- 4- Ifb
- 5- Out



## Functional Block Diagram

All values are typical



## Truth Table

Op. Conditions	Input	Output	I <sub>fb</sub> pin voltage
Normal mode	H	L	0V
Normal mode	L	H	I <sub>load</sub> x R <sub>fb</sub> / Ratio
Open load	H	L	0V
Open load	L	H	I <sub>fb</sub> leakage x R <sub>fb</sub>
Short circuit to GND	H	L	0V
Short circuit to GND	L	L	I <sub>fault</sub> x R <sub>fb</sub> (latched)
Over temperature	H	L	0V
Over temperature	L	L	I <sub>fault</sub> x R <sub>fb</sub> (latched)

## Operating voltage

**Maximum V<sub>cc</sub> voltage** : this is the maximum voltage before the breakdown of the IC process.

**Operating voltage** : This is the V<sub>cc</sub> range in which the functionality of the part is guaranteed. The AEC-Q100 qualification is run at the maximum operating voltage specified in the datasheet.

## Reverse battery

During the reverse battery the Mosfet is turned on if the input pin is powered with a diode in parallel of the input transistor. Power dissipation in the IPS :  $P = R_{ds(on)} \cdot I_{load}^2 + V_{cc}^2 / 250$  ( internal input resistor ).

If the power dissipation is too high in R<sub>fb</sub>, a diode in serial can be added to block the current.

## Active clamp

The purpose of the active clamp is to limit the voltage across the MOSFET to a value below the body diode break down voltage to reduce the amount of stress on the device during switching.

The temperature increase during active clamp can be estimated as follows:

$$\Delta T_j = P_{CL} \cdot Z_{TH}(t_{CLAMP})$$

Where:  $Z_{TH}(t_{CLAMP})$  is the thermal impedance at  $t_{CLAMP}$  and can be read from the thermal impedance curves given in the data sheets.

$P_{CL} = V_{CL} \cdot I_{CLavg}$  : Power dissipation during active clamp

$V_{CL} = 65V$  : Typical  $V_{CLAMP}$  value

$$I_{CLavg} = \frac{I_{CL}}{2} : \text{Average current during active clamp}$$

$$t_{CL} = \frac{I_{CL}}{\left| \frac{di}{dt} \right|} : \text{Active clamp duration}$$

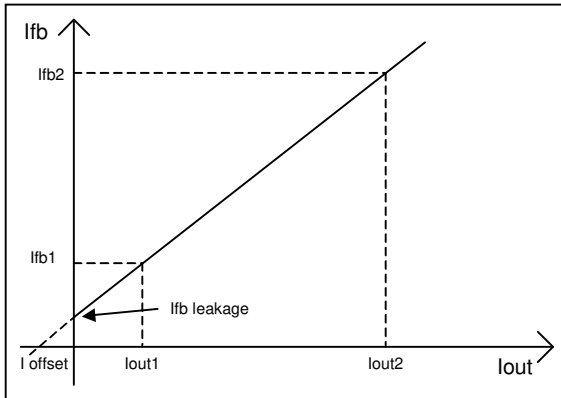
$$\frac{di}{dt} = \frac{V_{Battery} - V_{CL}}{L} : \text{Demagnetization current}$$

Figure 9 gives the maximum inductance versus the load current in the worst case : the part switches off after an over temperature detection. If the load inductance exceeds the curve, a free wheeling diode is required.

## Over-current protection

The threshold of the over-current protection is set in order to guarantee that the device is able to turn on a load with an inrush current lower than the minimum of I<sub>sd</sub>. Nevertheless for high current and high temperature the device may switch off for a lower current due to the over-temperature protection. This behavior is shown in Figure 11.

## Current sensing accuracy



The current sensing is specified by measuring 3 points :

- Ifb1 for Iout1
- Ifb2 for Iout2
- Ifb leakage for Iout=0

The parameters in the datasheet are computed with the following formula :

$$\text{Ratio} = (I_{out2} - I_{out1}) / (I_{fb2} - I_{fb1})$$

$$I_{offset} = I_{fb1} \times \text{Ratio} - I_{out1}$$

This allows the designer to evaluate the Ifb for any Iout value using :

$$I_{fb} = (I_{out} + I_{offset}) / \text{Ratio} \text{ if } I_{fb} > I_{fb \text{ leakage}}$$

For some applications, a calibration is required. In that case, the accuracy of the system will depend on the variation of the I offset and the ratio over the temperature range. The ratio variation is given by Ratio\_TC specified in page 4.

The I offset variation depends directly on the Rds(on) :

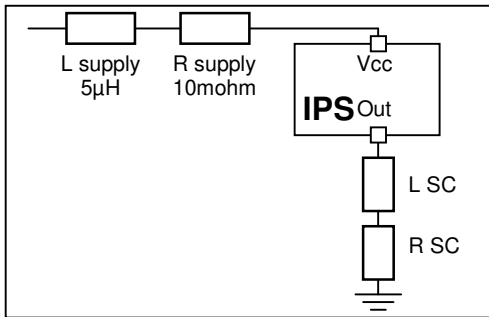
$$I_{offset@-40^{\circ}\text{C}} = I_{offset@25^{\circ}\text{C}} / 0.8$$

$$I_{offset@150^{\circ}\text{C}} = I_{offset@25^{\circ}\text{C}} / 1.9$$



### Maximum Vcc voltage with short circuit protection

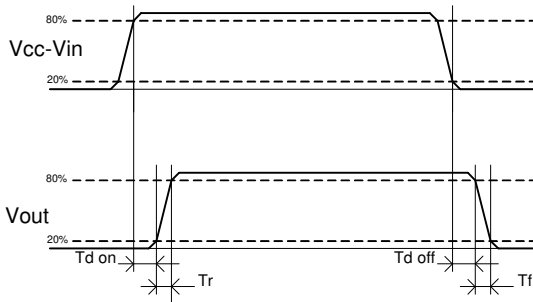
The maximum Vcc voltage with short circuit is the maximum voltage for which the part is able to protect itself under test conditions representative of the application. 2 kind of short circuits are considered : terminal and load short circuit.



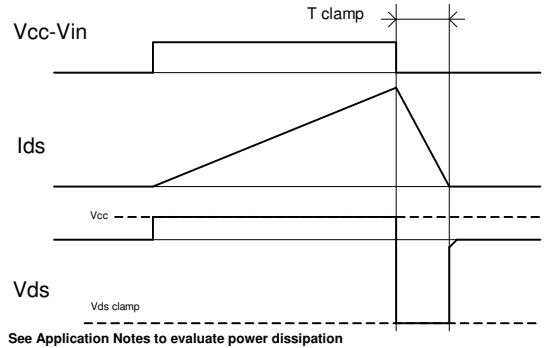
	L SC	R SC
Terminal SC	0.1 µH	10 mohm
Load SC	10 µH	100 mohm

### Maximum current during reverse circulation

In case of short circuit to battery, a voltage drop of the Vcc may create a current which circulate in reverse mode. When the device is on, this reverse circulation current will not trigger the internal fault latch. This immunization is also true when the part turns on while a reverse current flows into the device. The maximum current ( $I_{rev}$ ) is specified in the maximum rating section.

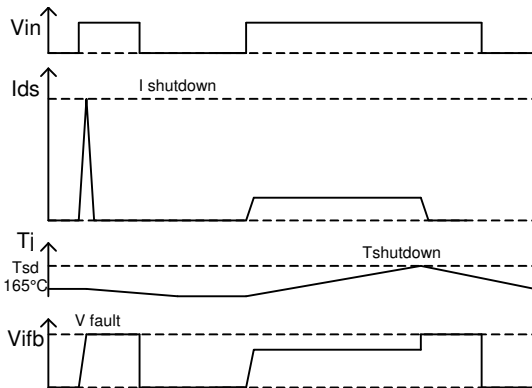


**Figure 1 – IN rise time & switching definitions**

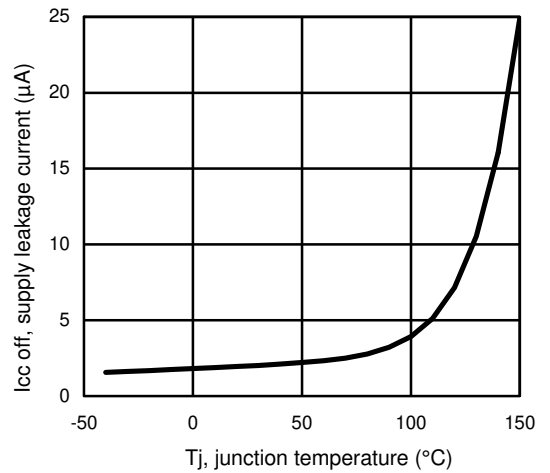


See Application NOTES to evaluate power dissipation

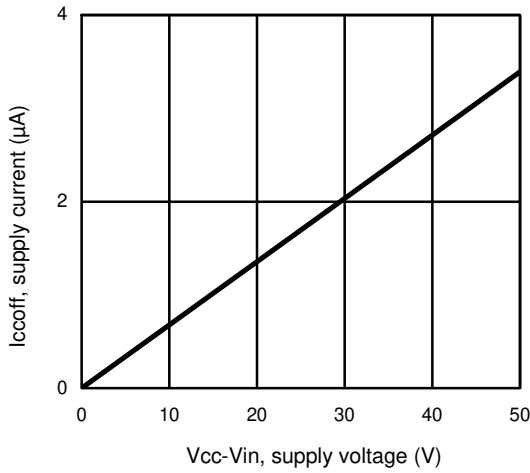
**Figure 2 – Active clamp waveforms**



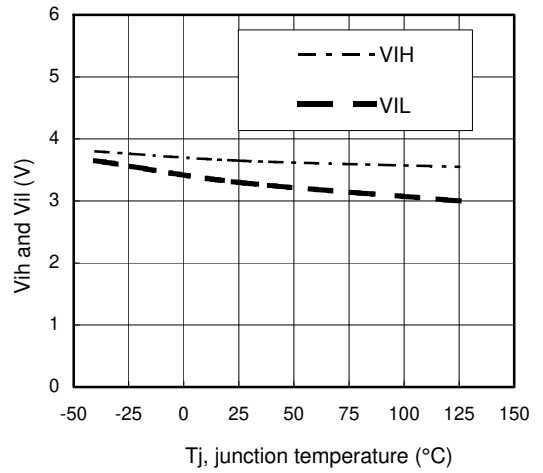
**Figure 3 – Protection timing diagram**



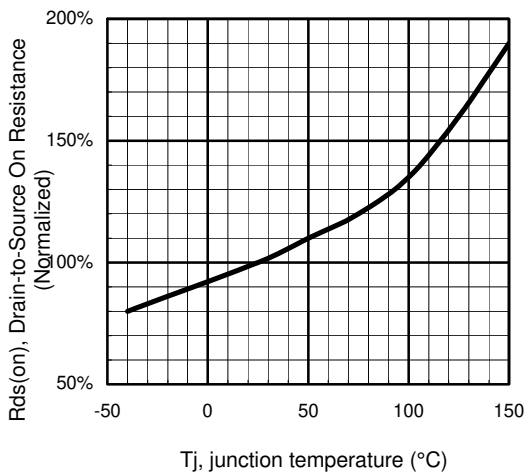
**Figure 4 – Icc off (µA) Vs Tj (°C)**



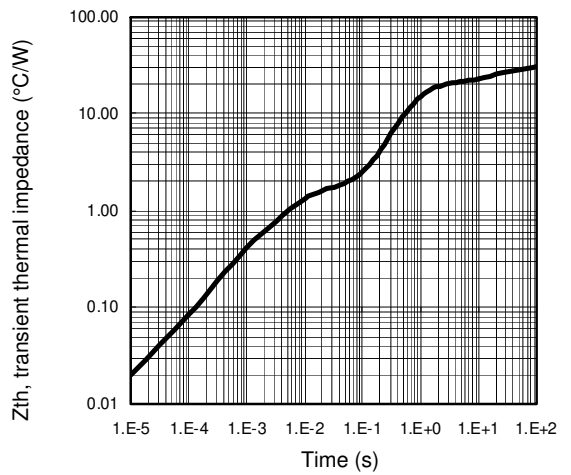
**Figure 5 – I<sub>cc off</sub>(µA) Vs V<sub>cc</sub>-V<sub>in</sub> (V)**



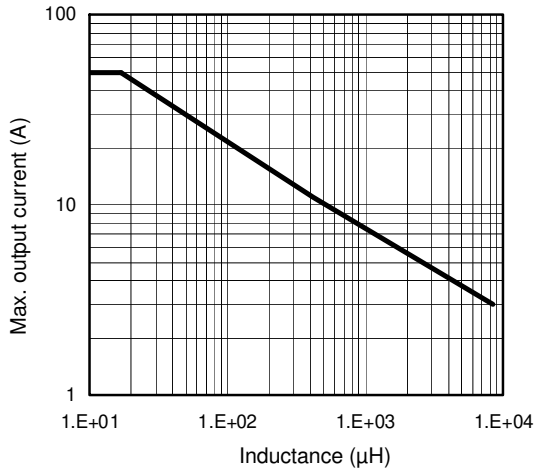
**Figure 6 – V<sub>ih</sub> and V<sub>il</sub> (V) Vs T<sub>j</sub> (°C)**



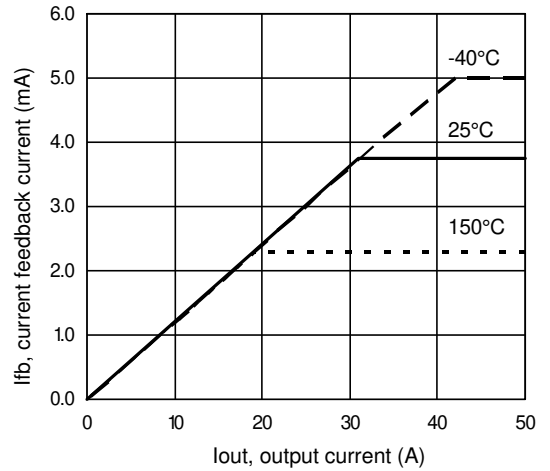
**Figure 7 - Normalized R<sub>ds(on)</sub> (%) Vs T<sub>j</sub> (°C)**



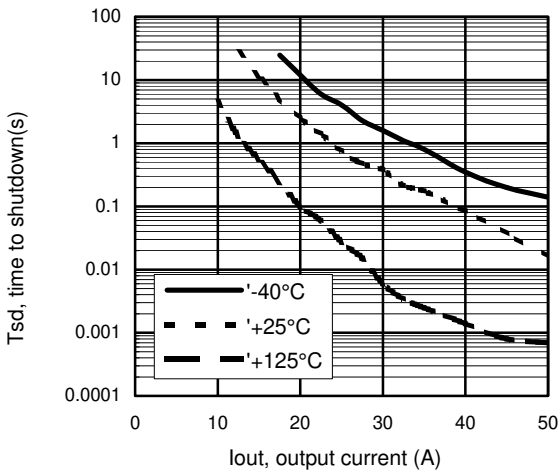
**Figure 8 – Transient thermal impedance (°C/W) Vs time (s)**



**Figure 9 – Max. I<sub>out</sub> (A) Vs inductance (µH)**

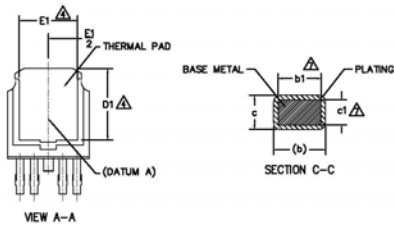
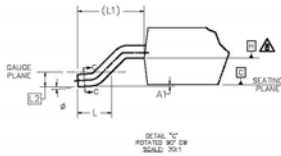


**Figure 10 – I<sub>fb</sub> (mA) Vs I<sub>out</sub> (A)**

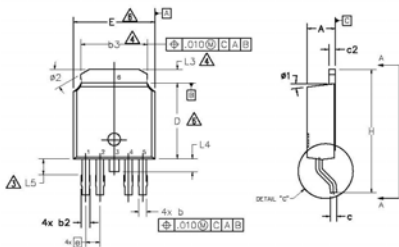


**Figure 11 – T<sub>sd</sub> (s) Vs I<sub>out</sub> (A)  
 SMD with 6cm<sup>2</sup>**

Case Outline 5 Lead – DPAK



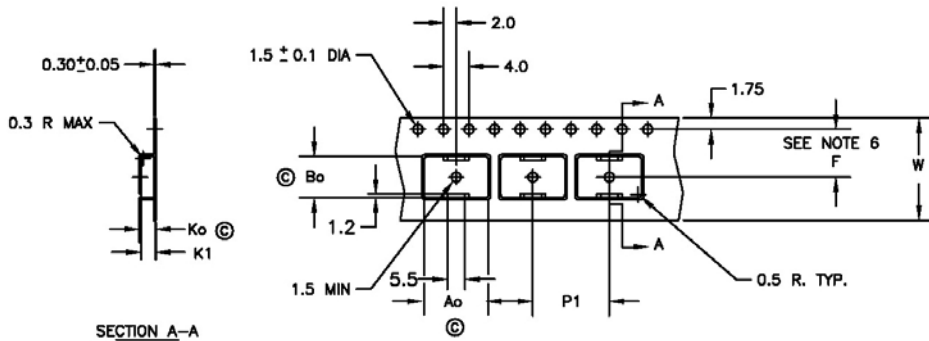
SYMBOL	DIMENSIONS				NOTES
	MILLIMETERS		INCHES		
	MIN.	MAX.	MIN.	MAX.	
A	2.18	2.39	.086	.094	
A1	—	0.13	—	.005	
b	0.56	0.79	.022	.031	2
b1	.056	0.74	.022	.029	
b2	0.65	0.89	.026	.035	
b3	4.95	5.46	.195	.215	2
c	0.46	0.61	.018	.024	
c1	0.41	0.56	.016	.022	2
c2	0.46	0.89	.018	.035	
D	5.97	6.22	.235	.245	3
D1	5.21	—	.205	—	
E	6.35	6.73	.250	.265	3
E1	4.32	—	.170	—	
e	1.14 BSC		.045 BSC		
H	9.40	10.41	.370	.410	
L	1.40	1.78	.055	.070	
L1	2.74 BSC		.108 REF.		
L2	0.51 BSC		.020 BSC		
L3	0.89	1.27	.035	.050	
L4	—	1.02	—	.040	
L5	1.14	1.52	.045	.060	
ø	0"	10"	0"	10"	
ø1	0"	15"	0"	15"	
ø2	28"	32"	28"	32"	



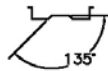
NOTES:

- 1.— DIMENSIONING AND TOLERANCING AS PER ASME Y14.5M-1994
- 2.— DIMENSION ARE SHOWN IN INCHES [MILLIMETERS]
- △ LEAD DIMENSION UNCONTROLLED IN L5.
- △ DIMENSION D1, E1, L3 & b3 ESTABLISH A MINIMUM MOUNTING SURFACE FOR THERMAL PAD.
- 5.— SECTION C-C DIMENSIONS APPLY TO THE FLAT SECTION OF THE LEAD BETWEEN .005 AND 0.10 [0.13 AND 0.25] FROM THE LEAD TIP.
- △ DIMENSION D & E DO NOT INCLUDE MOLD FLASH. MOLD FLASH SHALL NOT EXCEED .005 [0.13] PER SIDE. THESE DIMENSIONS ARE MEASURED AT THE OUTMOST EXTREMES OF THE PLASTIC BODY.
- △ DIMENSION b1 & c1 APPLIED TO BASE METAL ONLY.
- 8.— DATUM A & B TO BE DETERMINED AT DATUM PLANE H.
- 9.— OUTLINE CONFORMS TO JEDEC OUTLINE TO-252.
10. LEADS AND DRAIN ARE PLATED WITH 100% Sn

Tape & Reel 5 Lead – DPAK



SECTION A-A

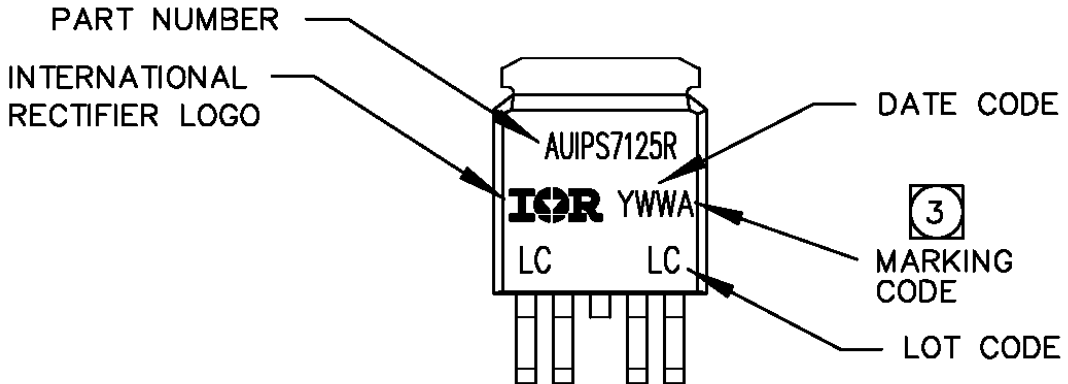


- Ao = 10.5 mm
- Bo = 7.0 mm
- Ko = 2.8 mm
- K1 = 2.4 mm
- F = 7.5 mm
- P1 = 12.0 mm
- W = 16.0 ± .3 mm

NOTES:

1. 10 SPROCKET HOLE PUNCH CUMULATIVE TOLERANCE ±.02
2. CAMBER NOT TO EXCEED 1mm IN 100mm
3. MATERIAL: CONDUCTIVE BLACK POLYSTYRENE
4. Ao AND Bo MEASURED ON A PLANE 0.3mm ABOVE THE BOTTOM OF THE POCKET
5. Ko MEASURED FROM A PLANE ON THE INSIDE BOTTOM OF THE POCKET TO THE TOP SURFACE OF THE CARRIER
6. POCKET POSITION RELATIVE TO THE SPROCKET HOLE MEASURED AS TRUE POSITION OF POCKET, NOT POCKET HOLE
7. VENDOR: (OPTIONAL)
8. MUST ALSO MEET REQUIREMENTS OF EIA STANDARD #EIA-481A, TAPING OF SURFACE-MOUNT COMPONENTS FOR AUTOMATIC PLACEMENT.
9. TOLERANCE TO BE MANUFACTURER STANDARD
10. SURFACE RESISTIVITY OF MOLDED MATL: MUST MEASURE LESS THAN OR EQUAL TO 10<sup>8</sup> OHMS PER SQUARE. MEASURED IN ACCORDANCE TO PROCEDURE GIVEN IN ASTM D-257 & ASTM D-991 (REF. C-9000 SPEC.)
11. TOTAL LENGTH PER REEL MUST BE 79 METERS
12. © CRITICAL DIMENSION

## Part Marking Information



## Ordering Information

Base Part Number	Package Type	Standard Pack		Complete Part Number
		Form	Quantity	
AUIPS7125R	D-Pak-5-Lead	Tube	75	AUIPS7125R
		Tape and reel	2000	AUIPS7125RTR
		Tape and reel left	3000	AUIPS7125RTRL
		Tape and reel right	3000	AUIPS7125RTRR

## **IMPORTANT NOTICE**

Unless specifically designated for the automotive market, International Rectifier Corporation and its subsidiaries (IR) reserve the right to make corrections, modifications, enhancements, improvements, and other changes to its products and services at any time and to discontinue any product or services without notice. Part numbers designated with the "AU" prefix follow automotive industry and / or customer specific requirements with regards to product discontinuance and process change notification. All products are sold subject to IR's terms and conditions of sale supplied at the time of order acknowledgment.

IR warrants performance of its hardware products to the specifications applicable at the time of sale in accordance with IR's standard warranty. Testing and other quality control techniques are used to the extent IR deems necessary to support this warranty. Except where mandated by government requirements, testing of all parameters of each product is not necessarily performed.

IR assumes no liability for applications assistance or customer product design. Customers are responsible for their products and applications using IR components. To minimize the risks with customer products and applications, customers should provide adequate design and operating safeguards.

Reproduction of IR information in IR data books or data sheets is permissible only if reproduction is without alteration and is accompanied by all associated warranties, conditions, limitations, and notices. Reproduction of this information with alterations is an unfair and deceptive business practice. IR is not responsible or liable for such altered documentation. Information of third parties may be subject to additional restrictions.

Resale of IR products or serviced with statements different from or beyond the parameters stated by IR for that product or service voids all express and any implied warranties for the associated IR product or service and is an unfair and deceptive business practice. IR is not responsible or liable for any such statements.

IR products are not designed, intended, or authorized for use as components in systems intended for surgical implant into the body, or in other applications intended to support or sustain life, or in any other application in which the failure of the IR product could create a situation where personal injury or death may occur. Should Buyer purchase or use IR products for any such unintended or unauthorized application, Buyer shall indemnify and hold International Rectifier and its officers, employees, subsidiaries, affiliates, and distributors harmless against all claims, costs, damages, and expenses, and reasonable attorney fees arising out of, directly or indirectly, any claim of personal injury or death associated with such unintended or unauthorized use, even if such claim alleges that IR was negligent regarding the design or manufacture of the product.

Only products certified as military grade by the Defense Logistics Agency (DLA) of the US Department of Defense, are designed and manufactured to meet DLA military specifications required by certain military, aerospace or other applications. Buyers acknowledge and agree that any use of IR products not certified by DLA as military-grade, in applications requiring military grade products, is solely at the Buyer's own risk and that they are solely responsible for compliance with all legal and regulatory requirements in connection with such use.

IR products are neither designed nor intended for use in automotive applications or environments unless the specific IR products are designated by IR as compliant with ISO/TS 16949 requirements and bear a part number including the designation "AU". Buyers acknowledge and agree that, if they use any non-designated products in automotive applications, IR will not be responsible for any failure to meet such requirements.

For technical support, please contact IR's Technical Assistance Center

<http://www.irf.com/technical-info/>

**WORLD HEADQUARTERS:**

101 N Sepulveda Blvd., El Segundo, California 90245

Tel: (310) 252-7105



**Revision History**

<b>Revision</b>	<b>Date</b>	<b>Notes/Changes</b>
A1	08/03/2010	
A2	29/04/2010	Correct packing information
A3	07/09/2010	Update current sensing capability
A4	31/05/2011	Final release
A5	06/06/2011	Update IR address