



Chipsmall Limited consists of a professional team with an average of over 10 year of expertise in the distribution of electronic components. Based in Hongkong, we have already established firm and mutual-benefit business relationships with customers from,Europe,America and south Asia,supplying obsolete and hard-to-find components to meet their specific needs.

With the principle of "Quality Parts,Customers Priority,Honest Operation,and Considerate Service",our business mainly focus on the distribution of electronic components. Line cards we deal with include Microchip,ALPS,ROHM,Xilinx,Pulse,ON,Everlight and Freescale. Main products comprise IC,Modules,Potentiometer,IC Socket,Relay,Connector.Our parts cover such applications as commercial,industrial, and automotives areas.

We are looking forward to setting up business relationship with you and hope to provide you with the best service and solution. Let us make a better world for our industry!



Contact us

Tel: +86-755-8981 8866 Fax: +86-755-8427 6832

Email & Skype: info@chipsmall.com Web: www.chipsmall.com

Address: A1208, Overseas Decoration Building, #122 Zhenhua RD., Futian, Shenzhen, China



Type AVEZ $-55\text{ }^{\circ}\text{C}$ to $+105\text{ }^{\circ}\text{C}$ Low Impedance SMT Aluminum Electrolytic Capacitors

For Filtering, Bypassing and Power Supply Decoupling



Type AVEZ Capacitors are rated for 1000 hours at $105\text{ }^{\circ}\text{C}$ with low impedance characteristics. They are ideal for high density PC board packaging. The Type AVEZ offers a low in-place-cost for a high quality performer. The vertical cylindrical cases facilitate automatic mounting and reflow soldering into the same footprint of like-rated tantalum capacitors except without the need for voltage derating. Type AVEZ is RoHS compliant.

Highlights

- $+105\text{ }^{\circ}\text{C}$, Up to 1000 Hours Load Life
- Capacitance Range: $1.0\text{ }\mu\text{F}$ to $220\text{ }\mu\text{F}$
- Voltage Range: 6.3 Vdc to 50 Vdc

Specifications

Operating Temperature:	$-55\text{ }^{\circ}\text{C}$ to $+105\text{ }^{\circ}\text{C}$
Rated Voltage:	6.3, 10, 16, 25, 35, 50 Vdc
Capacitance:	$1.0\text{ }\mu\text{F}$ to $220\text{ }\mu\text{F}$
Capacitance Tolerance:	$\pm 20\%$ @ 120 Hz and $+20\text{ }^{\circ}\text{C}$
Leakage Current:	$I = 0.01\text{ CV}$ or 3 (μA) whichever is greater after 2 minutes C = rated capacitance in μF , V = rated DC working voltage

Ripple Current Multiplier:

Vdc \ Freq. (Hz)	50, 60	120	1 k	10 k up
	6.3 ~ 50	0.64	0.80	0.93

Dissipation Factor: ($\text{Tan } \delta$ at 120 Hz, $20\text{ }^{\circ}\text{C}$)

Rated Voltage	6.3	10	16	25	35	50
Tan δ Max	0.28	0.24	0.20	0.16	0.14	0.12

Low Temperature Characteristic (at 120 Hz):

Rated Voltage		6.3	10	16	25	35	50
Impedance Ratio	$Z(-25\text{ }^{\circ}\text{C}) / Z(+20\text{ }^{\circ}\text{C})$	4	3	2	2	2	2
	$Z(-40\text{ }^{\circ}\text{C}) / Z(+20\text{ }^{\circ}\text{C})$	8	5	4	3	3	3



Load Life Test:

Test Time	1,000 Hours
Capacitance Change	Within $\pm 25\%$ of initial value
Dissipation Factor	Less than 200% of specified value
Leakage Current	Within specified value

Complies with the EU Directive 2002/95/EC requirement restricting the use of Lead (Pb), Mercury (Hg), Cadmium (Cd), Hexavalent chromium (Cr(VI)), PolyBrominated Biphenyls (PBB) and PolyBrominated Diphenyl Ethers (PBDE).

* The above specifications shall be satisfied when the capacitors are restored to $20\text{ }^{\circ}\text{C}$ after the rated voltage is applied for 1,000 hrs at $105\text{ }^{\circ}\text{C}$

Shelf Life Test: Test time: 1000 hours; test limits are the same as those for life test.

Type AVEZ -55 °C to +105 °C Low Impedance SMT Aluminum Electrolytic Capacitors

Outline Drawing, Case Code & Dimensions Table

Fig. 1

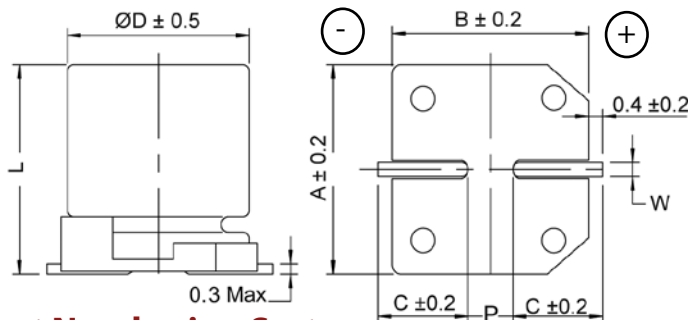

Case Code	Ø D (mm)	L (mm)	A (mm)	B (mm)	C (mm)	W (mm)	P ± 0.2 (mm)
B	4.0	5.3 ± 0.2	4.3	4.3	2.0	0.5 to 0.8	1.0
C	5.0	5.3 ± 0.2	5.3	5.3	2.3	0.5 to 0.8	1.5
D	6.3	5.3 ± 0.2	6.6	6.6	2.7	0.5 to 0.8	2.0
X	6.3	7.7 ± 0.3	6.6	6.6	2.7	0.5 to 0.8	2.0

Part Numbering System

AVEZ	106	M	25	C	12T	-F
Type	Capacitance	Capacitance Tolerance	Voltage Code	Case Code	Packaging Code	RoHS Compliant
AVEZ	105 = 1.0 µF 106 = 10.0 µF 107 = 100.0 µF	M = ±20%	06 = 6.3 Vdc 10 = 10 Vdc 16 = 16 Vdc 25 = 25 Vdc 35 = 35 Vdc 50 = 50 Vdc	See Table	12 = Carrier Tape Width (mm) T = Tape & Reel	

Ratings

Cap (µF)	Catalog Part Number	Max DCL 2 min. (µA)	Max DF 120 Hz 20 °C	Max Impedance 100 kHz 20 °C (ohms)	Max Ripple Current 100 kHz 105 °C (mA)	Case Code	Size D x L (mm)	Quantity per Reel (each)
6.3 Vdc (8 Vdc Surge)								
22	AVEZ226M06B12T-F	3.0	0.28	3.20	65	B	4 x 5.3	2000
33	AVEZ336M06C12T-F	3.0	0.28	1.50	110	C	5 x 5.3	1000
47	AVEZ476M06C12T-F	3.0	0.28	1.50	110	C	5 x 5.3	1000
100	AVEZ107M06D16T-F	6.3	0.28	0.85	170	D	6.3 x 5.3	1000
150	AVEZ157M06X16T-F	9.5	0.28	0.50	255	X	6.3 x 7.7	1000
220	AVEZ227M06X16T-F	13.9	0.28	0.50	255	X	6.3 x 7.7	1000
10 Vdc (13 Vdc Surge)								
10	AVEZ106M10B12T-F	3.0	0.24	3.20	65	B	4 x 5.3	2000
22	AVEZ226M10C12T-F	3.0	0.24	1.50	110	C	5 x 5.3	1000
33	AVEZ336M10C12T-F	3.0	0.24	1.50	110	C	5 x 5.3	1000
47	AVEZ476M10D16T-F	3.0	0.24	0.85	170	D	6.3 x 5.3	1000
100	AVEZ107M10D16T-F	6.3	0.24	0.85	170	D	6.3 x 5.3	1000
150	AVEZ157M10X16T-F	9.5	0.24	0.50	255	X	6.3 x 7.7	1000
220	AVEZ227M10X16T-F	13.9	0.24	0.50	255	X	6.3 x 7.7	1000

Type AVEZ **-55 °C to +105 °C**

Low Impedance SMT Aluminum Electrolytic Capacitors

Cap (μ F)	Catalog Part Number	Max DCL 2 min. (μ A)	Max DF 120 Hz 20 °C	Max Impedance 100 kHz 20 °C (ohms)	Max Ripple Current 100 kHz 105 °C (mA)	Case Code	Size D x L (mm)	Quantity per Reel (each)
16 Vdc (13 Vdc Surge)								
10	AVEZ106M16B12T-F	3.0	0.2	3.20	65	B	4 x 5.3	2000
22	AVEZ226M16C12T-F	3.0	0.2	1.50	110	C	5 x 5.3	1000
33	AVEZ336M16D16T-F	3.0	0.2	0.85	170	D	6.3 x 5.3	1000
47	AVEZ476M16D16T-F	3.0	0.2	0.85	170	D	6.3 x 5.3	1000
100	AVEZ107M16D16T-F	6.3	0.2	0.85	170	D	6.3 x 5.3	1000
150	AVEZ157M16X16T-F	9.5	0.2	0.50	255	X	6.3 x 7.7	1000
220	AVEZ227M16X16T-F	13.9	0.2	0.50	255	X	6.3 x 7.7	1000
25 Vdc (31 Vdc Surge)								
4.7	AVEZ475M25B12T-F	3.0	0.16	3.20	65	B	4 x 5.3	2000
10	AVEZ106M25C12T-F	3.0	0.16	1.50	110	C	5 x 5.3	1000
22	AVEZ226M25D16T-F	3.0	0.16	0.85	170	D	6.3 x 5.3	1000
33	AVEZ336M25D16T-F	3.0	0.16	0.85	170	D	6.3 x 5.3	1000
47	AVEZ476M25D16T-F	3.0	0.16	0.85	170	D	6.3 x 5.3	1000
100	AVEZ107M25X16T-F	6.3	0.16	0.5	255	X	6.3 x 7.7	1000
35 Vdc (44 Vdc Surge)								
4.7	AVEZ475M35B12T-F	3.0	0.14	3.20	65	B	4 x 5.3	2000
10	AVEZ106M35C12T-F	3.0	0.14	1.50	110	C	5 x 5.3	1000
22	AVEZ226M35D16T-F	3.0	0.14	0.85	170	D	6.3 x 5.3	1000
33	AVEZ336M35D16T-F	3.0	0.14	0.85	170	D	6.3 x 5.3	1000
47	AVEZ476M35X16T-F	3.0	0.14	0.50	255	X	6.3 x 7.7	1000
50 Vdc (63 Vdc Surge)								
1.0	AVEZ105M50B12T-F	3.0	0.12	5.0	30	B	4 x 5.3	2000
2.2	AVEZ225M50B12T-F	3.0	0.12	5.0	30	B	4 x 5.3	2000
3.3	AVEZ335M50B12T-F	3.0	0.12	5.0	30	B	4 x 5.3	2000
4.7	AVEZ475M50C12T-F	3.0	0.12	3.0	50	C	5 x 5.3	1000
10	AVEZ106M50D16T-F	3.0	0.12	2.0	70	D	6.3 x 5.3	1000
22	AVEZ226M50D16T-F	3.0	0.12	3.0	70	D	6.3 x 5.3	1000
33	AVEZ336M50X16T-F	3.0	0.12	1.0	170	X	6.3 x 7.7	1000

Type AVEZ $-55\text{ }^{\circ}\text{C}$ to $+105\text{ }^{\circ}\text{C}$ Low Impedance SMT Aluminum Electrolytic Capacitors

Recommended Land Patterns by case size for AVEZ series

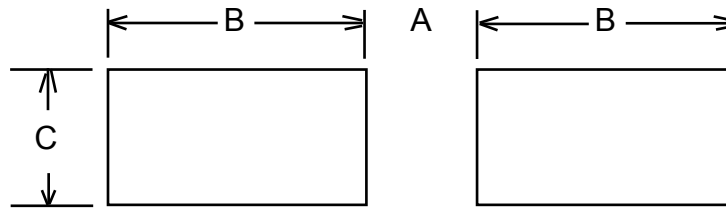

Case Code	Case Size	Land Dimensions (mm)		
		C	B	A
B	4x5.3	1.6	2.6	1
C	5x5.3	1.6	3	1.4
D	6.3x5.3	1.6	3.5	1.9
X	6.3x7.7	1.6	3.5	1.9

Recommended Soldering Methods

Recommended Reflow Soldering Profile:

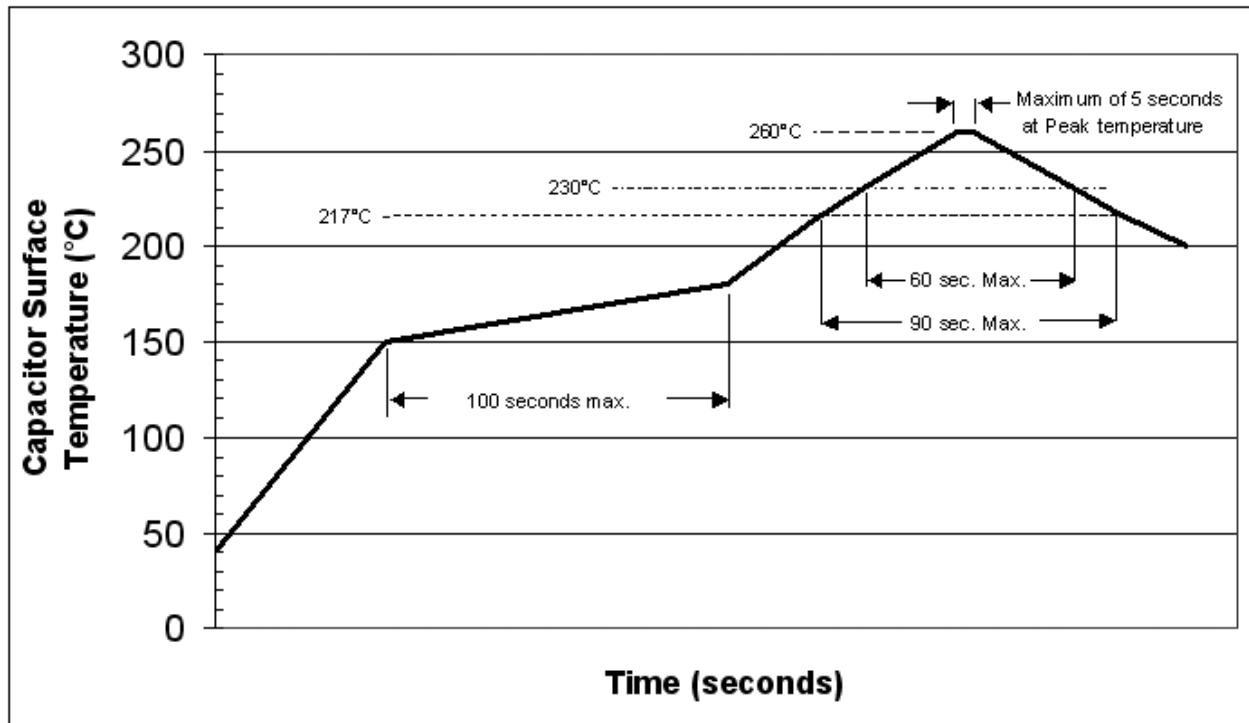

Parts should be subjected to just one reflow soldering process.

Soldering with a solder iron should be performed with a maximum soldering iron tip temperature of $350\pm 5\text{ }^{\circ}\text{C}$ for 3 to 4 seconds.

Type AVEZ $-55\text{ }^{\circ}\text{C}$ to $+105\text{ }^{\circ}\text{C}$

Low Impedance SMT Aluminum Electrolytic Capacitors

Notice and Disclaimer: All product drawings, descriptions, specifications, statements, information and data (collectively, the "Information") in this datasheet or other publication are subject to change. The customer is responsible for checking, confirming and verifying the extent to which the Information contained in this datasheet or other publication is applicable to an order at the time the order is placed. All Information given herein is believed to be accurate and reliable, but it is presented without any guarantee, warranty, representation or responsibility of any kind, expressed or implied. Statements of suitability for certain applications are based on the knowledge that the Cornell Dubilier company providing such statements ("Cornell Dubilier") has of operating conditions that such Cornell Dubilier company regards as typical for such applications, but are not intended to constitute any guarantee, warranty or representation regarding any such matter – and Cornell Dubilier specifically and expressly disclaims any guarantee, warranty or representation concerning the suitability for a specific customer application, use, storage, transportation, or operating environment. The Information is intended for use only by customers who have the requisite experience and capability to determine the correct products for their application. Any technical advice inferred from this Information or otherwise provided by Cornell Dubilier with reference to the use of any Cornell Dubilier products is given gratis (unless otherwise specified by Cornell Dubilier), and Cornell Dubilier assumes no obligation or liability for the advice given or results obtained. Although Cornell Dubilier strives to apply the most stringent quality and safety standards regarding the design and manufacturing of its products, in light of the current state of the art, isolated component failures may still occur. Accordingly, customer applications which require a high degree of reliability or safety should employ suitable designs or other safeguards (such as installation of protective circuitry or redundancies or other appropriate protective measures) in order to ensure that the failure of an electrical component does not result in a risk of personal injury or property damage. Although all product-related warnings, cautions and notes must be observed, the customer should not assume that all safety measures are indicated in such warnings, cautions and notes, or that other safety measures may not be required.