



Chipsmall Limited consists of a professional team with an average of over 10 year of expertise in the distribution of electronic components. Based in Hongkong, we have already established firm and mutual-benefit business relationships with customers from,Europe,America and south Asia,supplying obsolete and hard-to-find components to meet their specific needs.

With the principle of “Quality Parts,Customers Priority,Honest Operation,and Considerate Service”,our business mainly focus on the distribution of electronic components. Line cards we deal with include Microchip,ALPS,ROHM,Xilinx,Pulse,ON,Everlight and Freescale. Main products comprise IC,Modules,Potentiometer,IC Socket,Relay,Connector.Our parts cover such applications as commercial,industrial, and automotives areas.

We are looking forward to setting up business relationship with you and hope to provide you with the best service and solution. Let us make a better world for our industry!



## Contact us

Tel: +86-755-8981 8866 Fax: +86-755-8427 6832

Email & Skype: info@chipsmall.com Web: www.chipsmall.com

Address: A1208, Overseas Decoration Building, #122 Zhenhua RD., Futian, Shenzhen, China



## AUTOMATIC VOLTAGE SWITCH (SMPS < 200W)

### CONTROLLER

- 50/60Hz FULL COMPATIBILITY
- INTEGRATED VOLTAGE REGULATOR
- TRIGGERING PULSE TRAIN OF THE TRIAC
- PARASITIC FILTER
- LOW POWER CONSUMPTION

### TRIAC

- HIGH EFFICIENCY AND SAFETY SWITCHING
- UNINSULATED PACKAGE : AVS08CB
- INSULATED PACKAGE 2500V<sub>(RMS)</sub> : AVS08CBI
- $V_{DRM} = \pm 500 V$
- $I_{T(RMS)} : 5A$

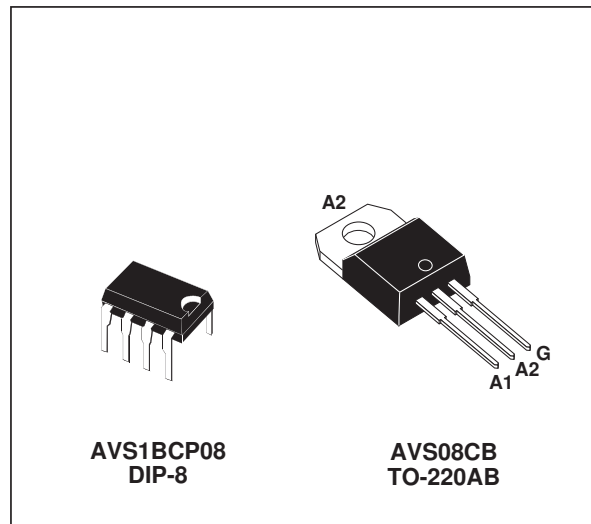

### DESCRIPTION

The AVS08 kit is an automatic mains selector (110/220V AC) to be used in SMPS < 200 W. It is composed of 2 devices :

- The **Controller** is optimized for low consumption and high security triggering of the triac. When connected to  $V_{SS}$ , the **mode** input activates an additional **option**. If the main power drops from 220V to 110V, the triac control remains locked to the 220V mode and avoids any high voltage spike when the voltage is restored to 220V. When connected to  $V_{DD}$ , the mode input deactivates this option.
- The **TRIAC** is specially designed for this application. An optimization between sensitivity and dynamic parameters of the triac gate highly reduces the losses of supply resistor and allows excellent immunity against disturbances.

### PIN CONNECTION

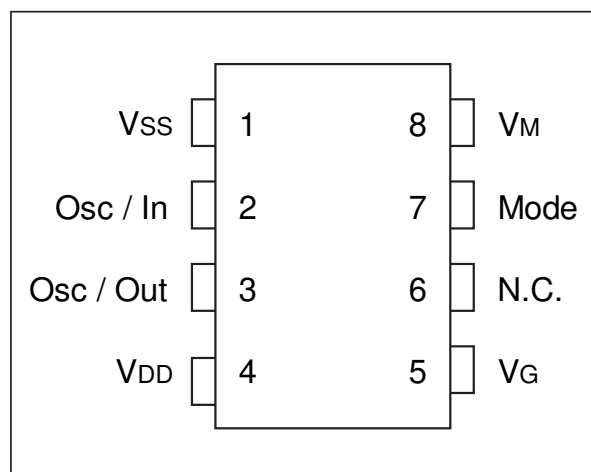

# AVS08

## BLOCK DIAGRAM

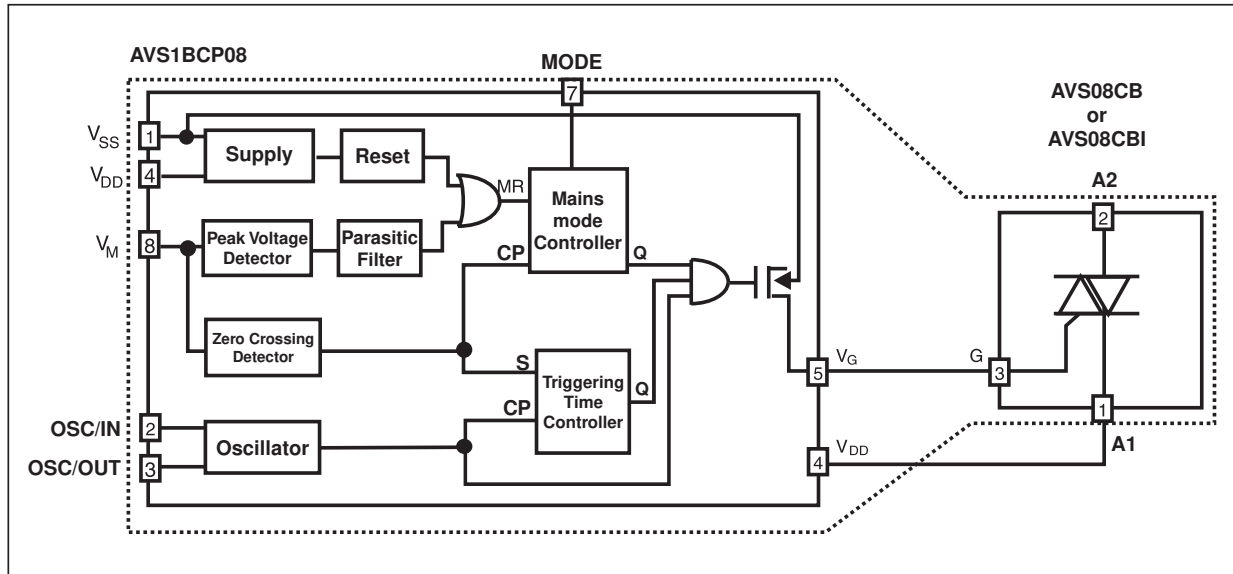

## ABSOLUTE MAXIMUM RATINGS CONTROLLER AVS1BCP08

Symbol	Parameter	Value		Unit
		Min.	Max.	
V <sub>SS</sub>	Supply voltage	-12	0.5	V
V <sub>I</sub> / V <sub>O</sub>	I / O voltage	V <sub>SS</sub> - 0.5	0.5	V
I <sub>I</sub> / I <sub>O</sub>	I / O current	-40	+40	mA
T <sub>stg</sub>	Storage Temperature	-60	+150	°C
T <sub>oper</sub>	Operating Temperature code "C"	0	+70	°C

## TRIAC AVS08CB / AVS08CBI T<sub>j</sub> = +25°C (unless otherwise specified)

Symbol	Parameter	Value	Unit	
V <sub>DRM</sub>	Repetitive peak off-state voltage (2)	± 500	V	
I <sub>T(RMS)</sub>	RMS on-state current (360° conduction angle)	AVS08CB T <sub>C</sub> = 100°C	5	A
		AVS08CBI T <sub>C</sub> = 95°C		
I <sub>TSM</sub>	Non repetitive surge peak on-state current ( T <sub>j</sub> initial = 25°C )	t = 8.3ms t = 10ms	70 65	A
I <sup>2</sup> t	I <sup>2</sup> t value	t = 10ms	21	A <sup>2</sup> s
di / dt	Critical rate of rise of on-state current (1)	Repetitive F = 50Hz	20	A/μs
		Non Repetitive	100	
T <sub>stg</sub> T <sub>j</sub>	Storage Temperature Junction Temperature Range	- 40 + 125 - 10 + 125	°C	

(1) Gate supply : I<sub>G</sub> = 100mA - di/dt = 1A/μs

(2) T<sub>j</sub> = 125°C

**THERMAL RESISTANCE**  
 TRIAC AVS08CB / AVS08CBI

Symbol	Parameter		Value	Unit
Rth (j-a)	Junction to ambient		60	°C/W
Rth (j-c) DC	Junction to case for DC	AVS08CB	5.4	°C/W
		AVS08CBI	6.3	
Rth (j-c) AC	Junction to case for 360° conduction angle (F = 50Hz)	AVS08CB	4.0	°C/W
		AVS08CBI	4.7	

**DC GENERAL ELECTRICAL CHARACTERISTICS**  
 TRIAC AVS08CB / AVS08CBI

Symbol	Parameter	Value		Unit
		Min.	Max.	
V <sub>TM</sub> *	I <sub>TM</sub> = 7A t <sub>p</sub> = 10ms T <sub>j</sub> = 25°C		1.65	V
I <sub>DRM</sub> *	V <sub>DRM</sub> rated Gate open T <sub>j</sub> = 25°C		10	μA

\* For either polarity of electrode A2 voltage with reference to electrode A1

**Fig. 1:** Maximum RMS power dissipation versus RMS on-state current (F = 60Hz).  
 (Curves are cut off by (di/dt)<sub>c</sub> limitation)

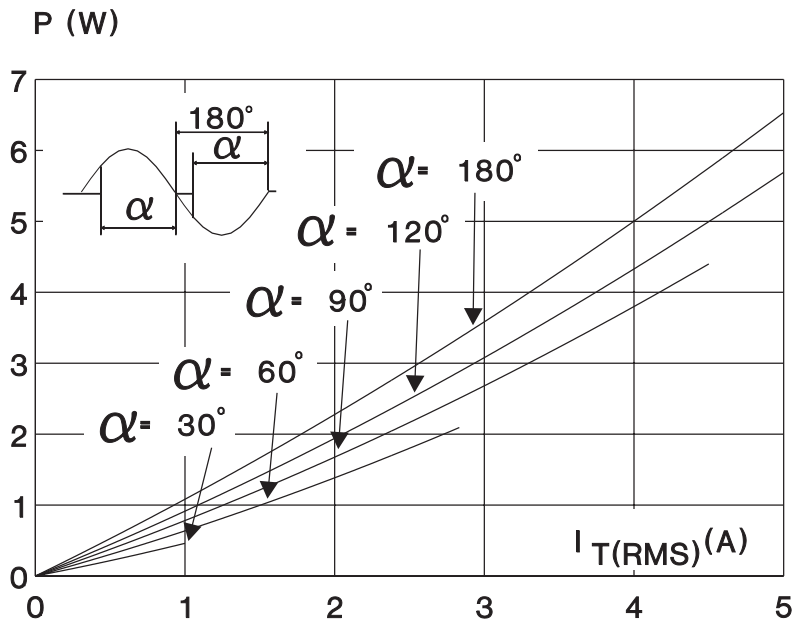

## AVS08

### DC GENERAL ELECTRICAL CHARACTERISTICS (continued) CONTROLLER AVS1BCP08 Toper = 25°C (unless otherwise specified)

Symbol	Parameter	Value			Unit
		Min.	Typ.	Max.	
V <sub>SS</sub> (pin 1) (Vreg)	Shunt regulator	-10	-9	-8	V
I <sub>SS</sub> (pin 1) (Vreg) (@ V <sub>SS</sub> = 9V)	Supply current	0.4		25	mA
I <sub>SS</sub> (pin 1) (@ triac gate non connected)	Quiescent current			1	mA
F (pin 3) (@ R = 91kΩ) (C = 100pF)	Oscillator frequency	42	44	46	KHz
V <sub>M</sub> (pin 8) V <sub>th</sub> (3)	Peak voltage of detection high-threshold	4.08	4.25	4.42	V
V <sub>M</sub> (pin 8) V <sub>h</sub> (3)	Peak voltage of detection hysteresis	0.370	0.4	0.420	V
(1) V <sub>M</sub> (pin 8) V <sub>th</sub> (3)	Zero-crossing detection high-threshold	95	110	125	mV
V <sub>M</sub> (pin 8) V <sub>h</sub> (3)	Zero-crossing detection hysteresis	27	50	80	mV
(2) V <sub>r</sub> azht (4)	Power-on-reset activation threshold		Vreg x 0.89		V
(2) V <sub>r</sub> azlt (4)	Power-down-reset activation threshold	3		6.95	V
Mode (pin 7)	V <sub>IL</sub> (4) V <sub>IH</sub> (4)	0.7 Vreg		0.3 Vreg	V
V <sub>G</sub> (pin 5)	V <sub>OL</sub> (I <sub>VG</sub> = 25mA) Leakage current (V <sub>G</sub> = V <sub>DD</sub> )			1 + 50	V μA

#### NOTE:

- (1) : This value gives a typical noise immunity on the zero-crossing detection of 110mV x 1018/18 = 6.20V on the main supply
- (2) : See following diagram
- (3) : Voltage referred to V<sub>SS</sub>
- (4) : Voltage referred to V<sub>DD</sub>

### POWER-ON AND POWER-OFF RESET BEHAVIOUR

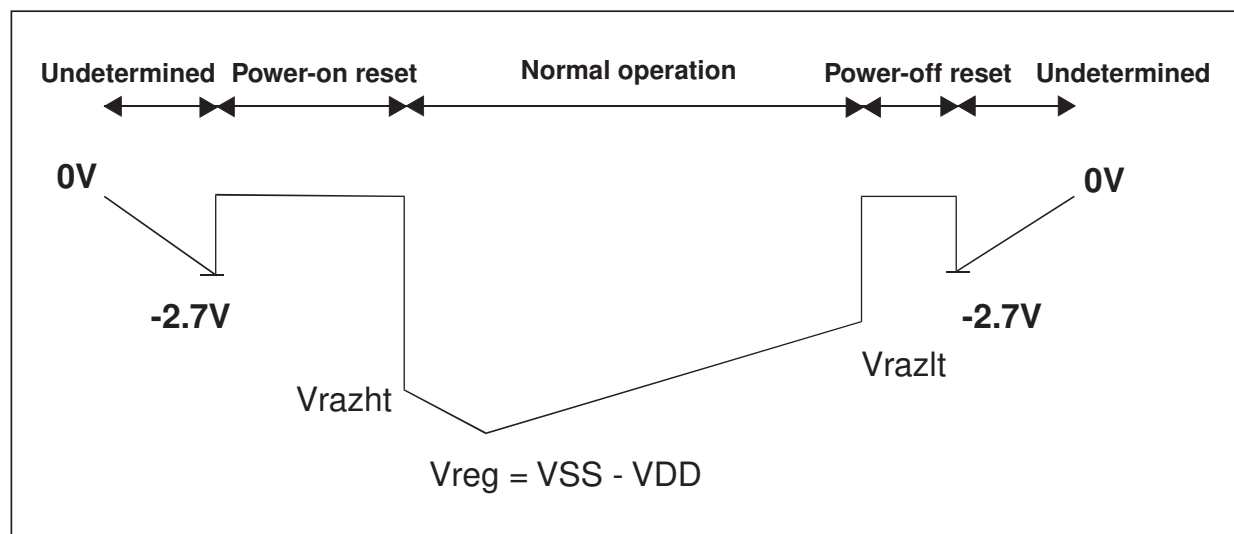

TYPICAL APPLICATION

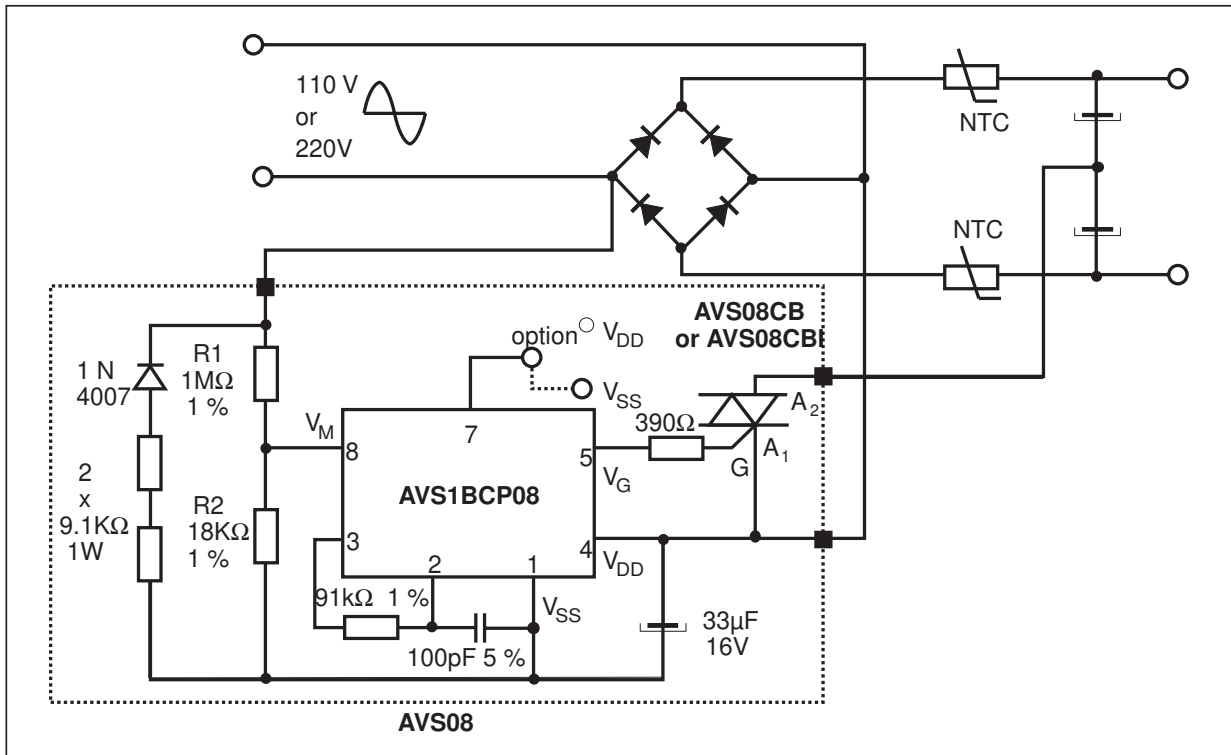

ORDERING INFORMATION

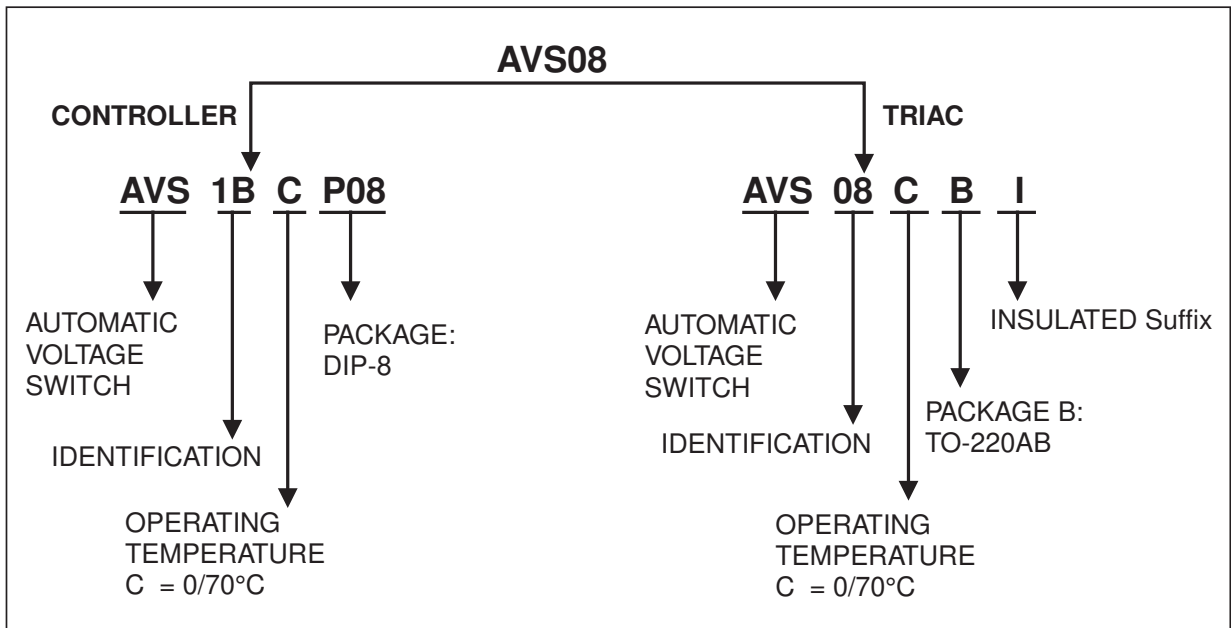

**PACKAGE MECHANICAL DATA**  
DIP-8 Plastic (controller)

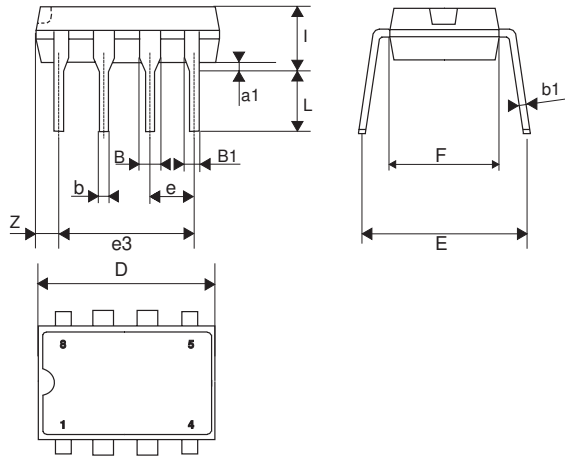

REF.	DIMENSIONS					
	Millimetres			Inches		
	Min.	Typ.	Max.	Min.	Typ.	Max.
a1	0.70			0.027		
B	1.39		1.65	0.055		0.065
B1	0.91		1.04	0.036		0.041
b		0.5			0.020	
b1	0.38		0.50	0.015		0.020
D			9.80			0.385
E		8.8			0.346	
e		2.54			0.100	
e3		7.62			0.300	
F			7.1			0.280
I			4.8			0.189
L		3.3			0.130	
Z	0.44		1.60	0.017		0.063

**PACKAGE MECHANICAL DATA**  
 TO-220AB (Plastic) (Triac)

REF.	DIMENSIONS					
	Millimeters			Inches		
	Min.	Typ.	Max.	Min.	Typ.	Max.
A	15.20		15.90	0.598		0.625
a1		3.75			0.147	
a2	13.00		14.00	0.511		0.551
B	10.00		10.40	0.393		0.409
b1	0.61		0.88	0.024		0.034
b2	1.23		1.32	0.048		0.051
C	4.40		4.60	0.173		0.181
c1	0.49		0.70	0.019		0.027
c2	2.40		2.72	0.094		0.107
e	2.40		2.70	0.094		0.106
F	6.20		6.60	0.244		0.259
I	3.75		3.85	0.147		0.151
I4	15.80	16.40	16.80	0.622	0.646	0.661
L	2.65		2.95	0.104		0.116
I2	1.14		1.70	0.044		0.066
I3	1.14		1.70	0.044		0.066
M		2.60			0.102	

- Cooling method: C
- Recommended torque value: 0.8 m.N
- Maximum torque value: 1 m.N

**OTHER INFORMATION**

Part Number	Marking	Weight	Base Qty	Packing mode
AVS08CB	AVS08CB	2.3 g	1000	Tube
AVS08CBI	AVS08CBI	2.3 g	1000	Tube
AVS1BCP08	AVS1BCP08	0.6 g	2000	Tube

Information furnished is believed to be accurate and reliable. However, STMicroelectronics assumes no responsibility for the consequences of use of such information nor for any infringement of patents or other rights of third parties which may result from its use. No license is granted by implication or otherwise under any patent or patent rights of STMicroelectronics. Specifications mentioned in this publication are subject to change without notice. This publication supersedes and replaces all information previously supplied. STMicroelectronics products are not authorized for use as critical components in life support devices or systems without express written approval of STMicroelectronics.

The ST logo is a registered trademark of STMicroelectronics  
 © 2002 STMicroelectronics - Printed in Italy - All rights reserved.

STMicroelectronics GROUP OF COMPANIES  
 Australia - Brazil - Canada - China - Finland - France - Germany  
 Hong Kong - India - Israel - Italy - Japan - Malaysia - Malta - Morocco - Singapore  
 Spain - Sweden - Switzerland - United Kingdom - United States.

<http://www.st.com>

