



Chipsmall Limited consists of a professional team with an average of over 10 year of expertise in the distribution of electronic components. Based in Hongkong, we have already established firm and mutual-benefit business relationships with customers from,Europe,America and south Asia,supplying obsolete and hard-to-find components to meet their specific needs.

With the principle of “Quality Parts,Customers Priority,Honest Operation,and Considerate Service”,our business mainly focus on the distribution of electronic components. Line cards we deal with include Microchip,ALPS,ROHM,Xilinx,Pulse,ON,Everlight and Freescale. Main products comprise IC,Modules,Potentiometer,IC Socket,Relay,Connector.Our parts cover such applications as commercial,industrial, and automotives areas.

We are looking forward to setting up business relationship with you and hope to provide you with the best service and solution. Let us make a better world for our industry!



Contact us

Tel: +86-755-8981 8866 Fax: +86-755-8427 6832

Email & Skype: info@chipsmall.com Web: www.chipsmall.com

Address: A1208, Overseas Decoration Building, #122 Zhenhua RD., Futian, Shenzhen, China



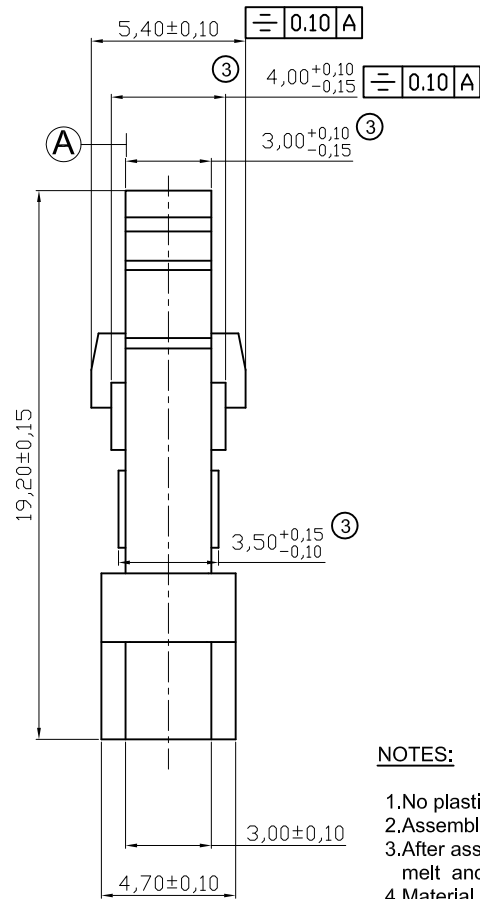
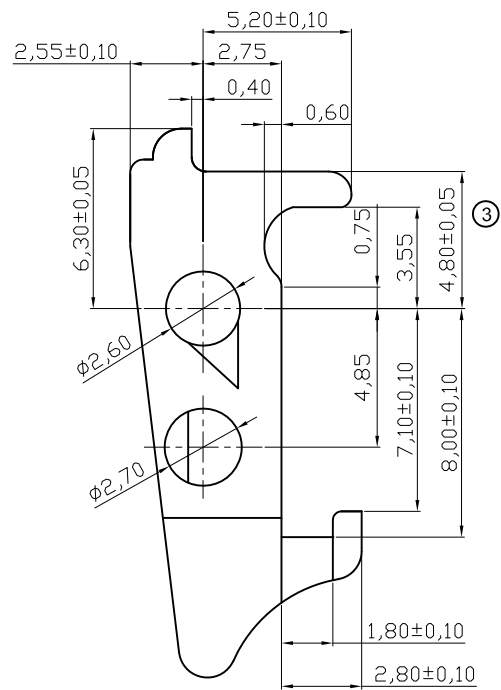

NOTES:

- 1.No plastic deformation on the surface,burr less then 0.05mm
- 2.Assembly with 2.54 header,no plastic deformation ,good latch assembly
- 3.After assembly, wave-soldering(235°C 5sec),no plastic deformation , melt and so no.
- 4.Material : PBT+30%GF UL94V-0

RoHS compliant

Scale	1:1						Date	Name	Customer-No.	
TOLERANCE						Drawn	07.01.2002	Hellwig		
X.X	±0.10					Approved	04.05.2010	Hellwig	ASSMANN WSW-No.	
X.XX	±0.05								AWHCLIP XSHORT	
X.XXX	±0.02	③	Modify dimensions	04.05.2010	Dean				Drawing-No.	
DIM	TOL	②	Modify P/N	17.02.2009	Dean	ASSMANN WSW components			ASS 1184 CO	rev03
X.°	±2°	①	Drawn	07.01.2002	Hellwig					
X.X°	±X°									
Angle	TOL	Id.	Modification	Date	Name				Replace	Sheet 1 OF 2

1

2

3

4

5

6

7

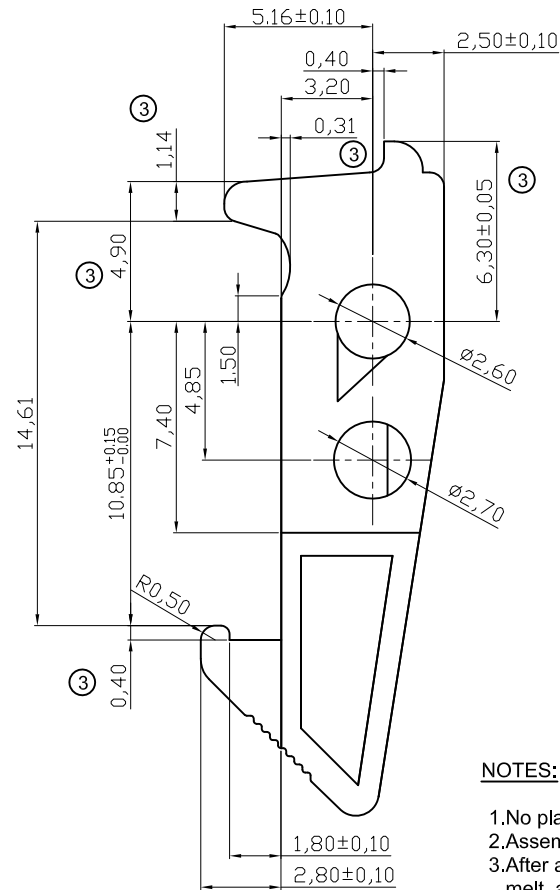
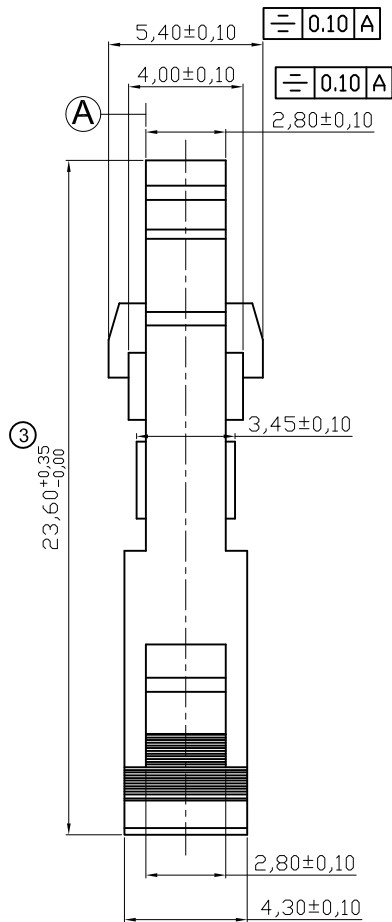

NOTES:

- 1.No plastic deformation on the surface,burr less then 0.05mm
- 2.Assembly with 2.54 header,no plastic deformation ,good latch assembly
- 3.After assembly, wave-soldering(235°C 6sec),no plastic deformation , melt and so no.
- 4.Material : PBT+30%GF UL94V-0

RoHS compliant

Scale	1:1					Date	Name	Customer-No.
TOLERANCE						Drawn	07.01.2002	Hellwig
X.X	±0.10					Approved	04.05.2010	Hellwig
X.XX	±0.05							ASSMANN WSW-No.
X.XXX	±0.02	③	Modify dimensions	04.05.2010	Dean			AWHCLIP LONG
DIM	TOL	②	Modify P/N	17.02.2009	Dean			Drawing-No.
X.°	±2°							ASS 1184 CO
X.X°	±X°	①	Drawn	07.01.2002	Hellwig			rev03
Angle	TOL	Id.	Modification	Date	Name			Sheet
								Replace

