



Chipsmall Limited consists of a professional team with an average of over 10 year of expertise in the distribution of electronic components. Based in Hongkong, we have already established firm and mutual-benefit business relationships with customers from,Europe,America and south Asia,supplying obsolete and hard-to-find components to meet their specific needs.

With the principle of "Quality Parts,Customers Priority,Honest Operation,and Considerate Service",our business mainly focus on the distribution of electronic components. Line cards we deal with include Microchip,ALPS,ROHM,Xilinx,Pulse,ON,Everlight and Freescale. Main products comprise IC,Modules,Potentiometer,IC Socket,Relay,Connector.Our parts cover such applications as commercial,industrial, and automotives areas.

We are looking forward to setting up business relationship with you and hope to provide you with the best service and solution. Let us make a better world for our industry!



## Contact us

Tel: +86-755-8981 8866 Fax: +86-755-8427 6832

Email & Skype: info@chipsmall.com Web: www.chipsmall.com

Address: A1208, Overseas Decoration Building, #122 Zhenhua RD., Futian, Shenzhen, China



NOTES:

1. CONNECTOR MATERIAL:  
HOUSING:THERMOPLASTIC BLACK UL94 V-0  
SHIELD:Brass  
SHIELD PLATING:NICKEL  
CONTACT:PHOSPHOR BRONZE  
CONTACT PLATING: SELECTIVE GOLD, 30 MICRO-INCHS MIN  
IN CONTACT AREA
2. PIN NOT ELECTRICALLY CONNECTED MAYBE OMITTED SEE  
ELECTRICAL DRAWING FOR OMITTED PINS
3. RJ45 CAVITIES CONFORM TO FCC RULES AND REGULATION  
PART 68.
4. THE PART IS RECOMMENDED FOR WAVE SOLDERING  
PROCESS PEAK SOLDERING TEMPERATURE IS  
260°C MAX, 10 SECS MAX
5. OPERATING TEMPERATURE T=-40°C TO +85°C.
6. STORAGE TEMPERATURE T=-40°C TO +85°C.
7. PACKAGING INFORMATION: 50 PCS/ TRAY, 1200 PCS/BOX.

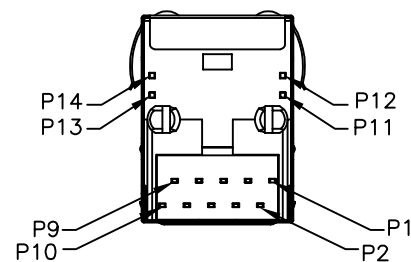
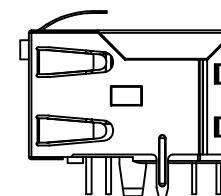
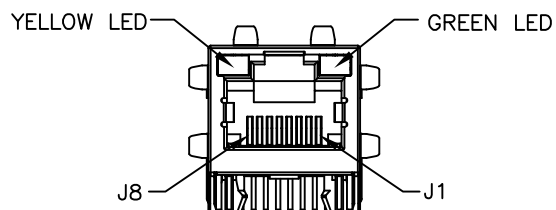
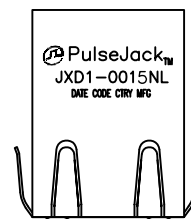

FINAL OUTLINE

© Copyright, 2015. Pulse Electronics Corp. All rights reserved. Pulse confidential & proprietary. (03/15/16)

PRODUCT DESCRIPTION	TLA DRAWING	PS DRAWING	SHEET	PART NO.	DATASHEET REV.
CONN,RJ45,1X1,1GD,1:1,TU	JXD1-0015NL-X1	-	1 OF 5	JXD1-0015NL	A

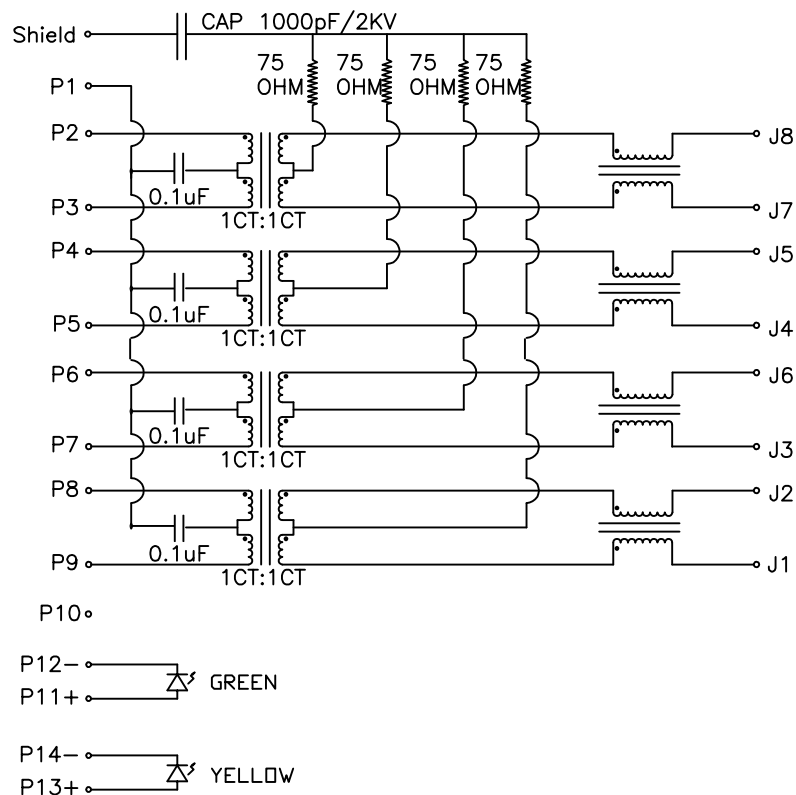

SCHEMATIC

Electronical Specifications:

- 1.0 Turn Ratio @100KHz: (P9~P8):(J1~J2) = 1:1±5%  
(P7~P6):(J3~J6) = 1:1±5%  
(P5~P4):(J4~J5) = 1:1±5%  
(P3~P2):(J7~J8) = 1:1±5%
- 2.0 Primary Inductance: 350uH MIN @100KHZ, 0.1V 8mA DC BIAS
- 3.0 DC Resistance: 1.2 OHMS MAX
- 4.0 Insertion Loss: 1-100MHz -1.0dB MAX  
100-125MHz -1.2dB MAX
- 5.0 Return Loss: 1-40MHz -16dB MIN  
40-60MHz -12dB MIN  
60-80MHz -10dB MIN  
80-100MHz -8dB MIN
- 6.0 CROSS TALK: 1-100MHz -30dB MIN
- 7.0 COMMON TO COMMON MODE ATTENUATION: 1-100MHz -30dB MIN
- 8.0 Isolation: PHY Side to Line Side: 2250VDC

LED SPECIFICATION

STANDARD LED	WAVELENGTH	Forward Current	Forward V(max)	TYP
GREEN	565nm	20 mA	2.4V	2.2V
YELLOW	590nm	20 mA	2.5V	2.1V

© Copyright, 2015. Pulse Electronics Corp. All rights reserved. Pulse confidential & proprietary. (03/15/16)

PRODUCT DESCRIPTION	TLA DRAWING	PS DRAWING	SHEET	PART NO.	DATASHEET REV.
CONN,RJ45,1X1,1GD,1:1,TU	JXD1-0015NL-X1	-	2 OF 5	JXD1-0015NL	A

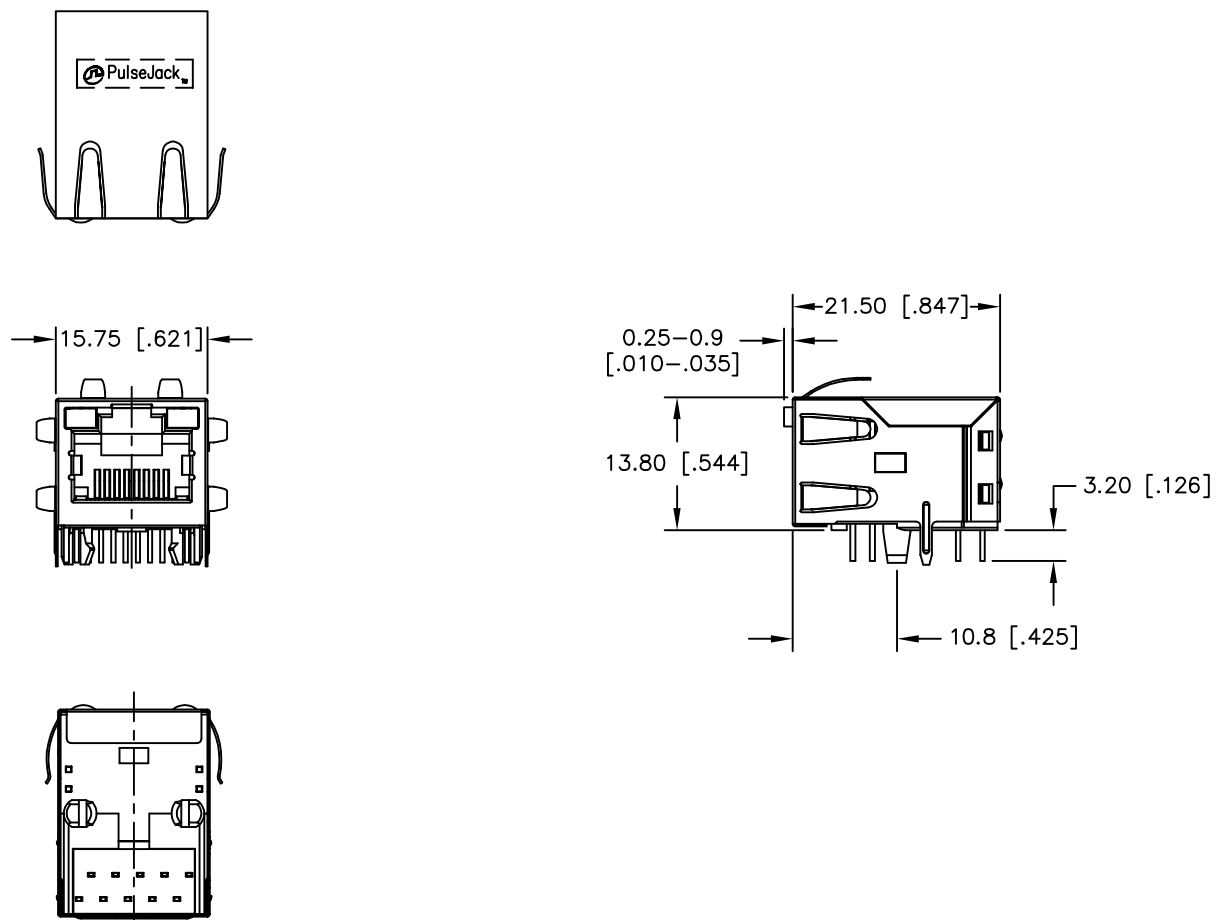

DIMENSIONS ARE IN MILLIMETERS [INCHES] WITH THE FOLLOWING TOLERANCES: [INCHES] ARE FOR REFERENCE ONLY.  
X.XX=  $\pm 0.25$  [ $\pm 0.010$ ]

© Copyright, 2015. Pulse Electronics Corp. All rights reserved. Pulse confidential & proprietary. (03/15/16)

PRODUCT DESCRIPTION	TLA DRAWING	PS DRAWING	SHEET	PART NO.	DATASHEET REV.
CONN,RJ45,1X1,1GD,1:1,TU	JXD1-0015NL-X1	-	3 OF 5	JXD1-0015NL	A

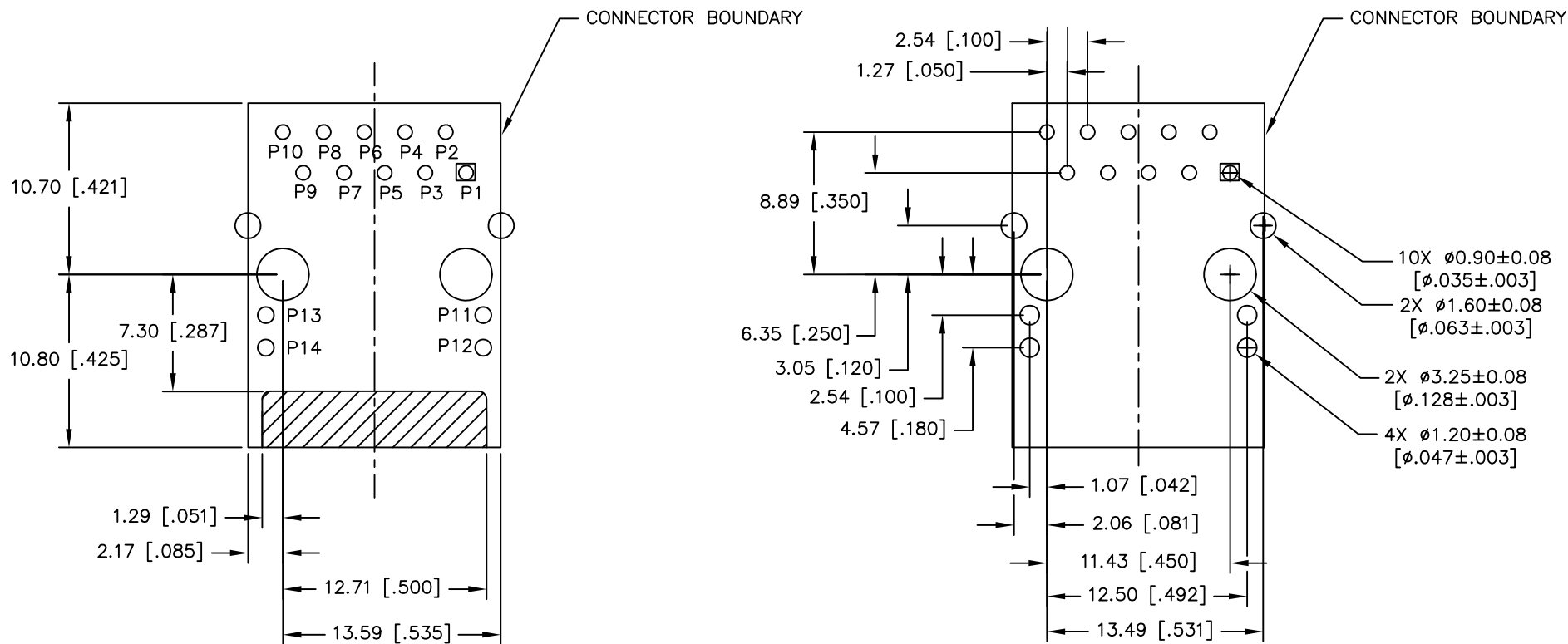

KEEP-OUT AREA (COMPONENT SIDE SHOWN)

RECOMMENDED PWB LAYOUT (COMPONENT SIDE SHOWN)

DIMENSIONS ARE IN MILLIMETERS [INCHES] WITH THE FOLLOWING TOLERANCES: [INCHES] ARE FOR REFERENCE ONLY.  
X.XX= ±0.10 [±.004]

© Copyright, 2015. Pulse Electronics Corp. All rights reserved. Pulse confidential & proprietary. (03/15/16)

PRODUCT DESCRIPTION	TLA DRAWING	PS DRAWING	SHEET	PART NO.	DATASHEET REV.
CONN,RJ45,1X1,1GD,1:1,TU	JXD1-0015NL-X1	-	4 OF 5	JXD1-0015NL	A

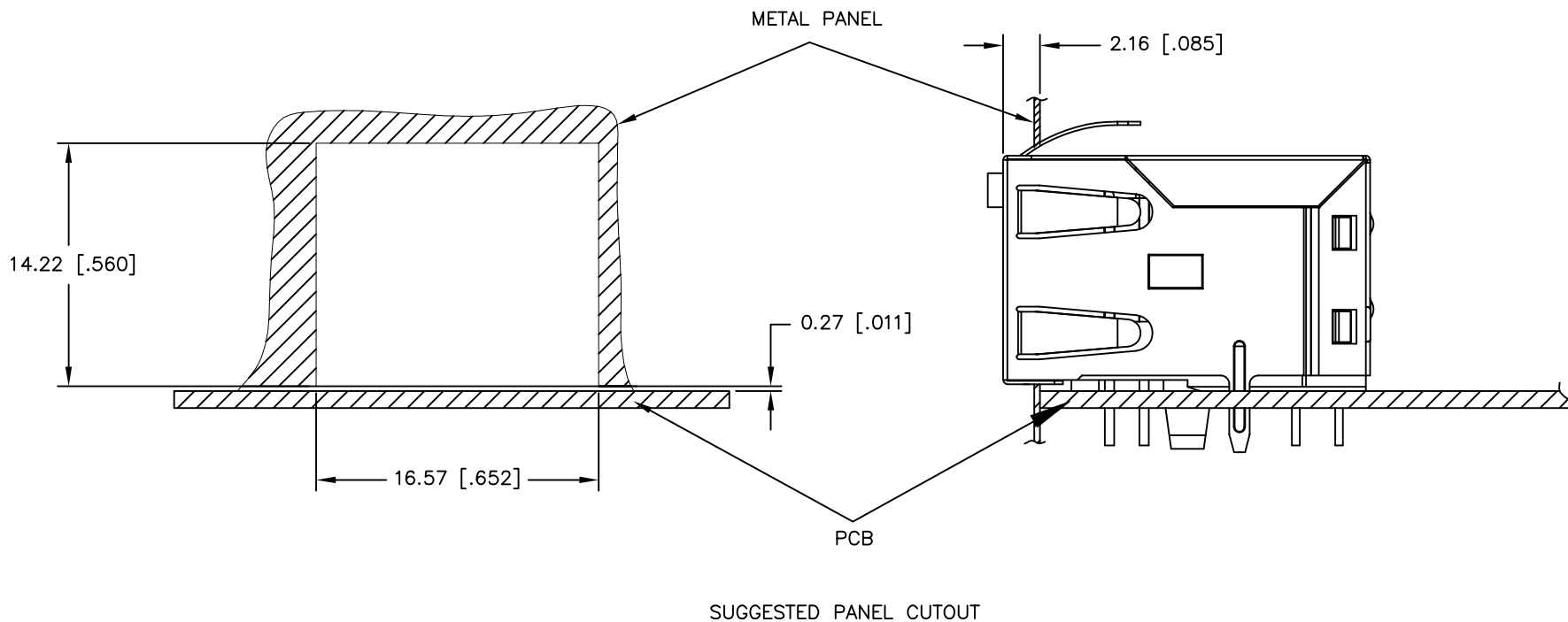

DIMENSIONS ARE IN MILLIMETERS [INCHES] WITH THE FOLLOWING TOLERANCES: [INCHES] ARE FOR REFERENCE ONLY.  
X.XX=  $\pm 0.10$  [ $\pm 0.004$ ]

© Copyright, 2015. Pulse Electronics Corp. All rights reserved. Pulse confidential & proprietary. (03/15/16)

PRODUCT DESCRIPTION	TLA DRAWING	PS DRAWING	SHEET	PART NO.	DATASHEET REV.
CONN,RJ45,1X1,1GD,1:1,TU	JXD1-0015NL-X1	-	5 OF 5	JXD1-0015NL	A