



Chipsmall Limited consists of a professional team with an average of over 10 year of expertise in the distribution of electronic components. Based in Hongkong, we have already established firm and mutual-benefit business relationships with customers from,Europe,America and south Asia,supplying obsolete and hard-to-find components to meet their specific needs.

With the principle of "Quality Parts,Customers Priority,Honest Operation,and Considerate Service",our business mainly focus on the distribution of electronic components. Line cards we deal with include Microchip,ALPS,ROHM,Xilinx,Pulse,ON,Everlight and Freescale. Main products comprise IC,Modules,Potentiometer,IC Socket,Relay,Connector.Our parts cover such applications as commercial,industrial, and automotives areas.

We are looking forward to setting up business relationship with you and hope to provide you with the best service and solution. Let us make a better world for our industry!



## Contact us

Tel: +86-755-8981 8866 Fax: +86-755-8427 6832

Email & Skype: info@chipsmall.com Web: www.chipsmall.com

Address: A1208, Overseas Decoration Building, #122 Zhenhua RD., Futian, Shenzhen, China



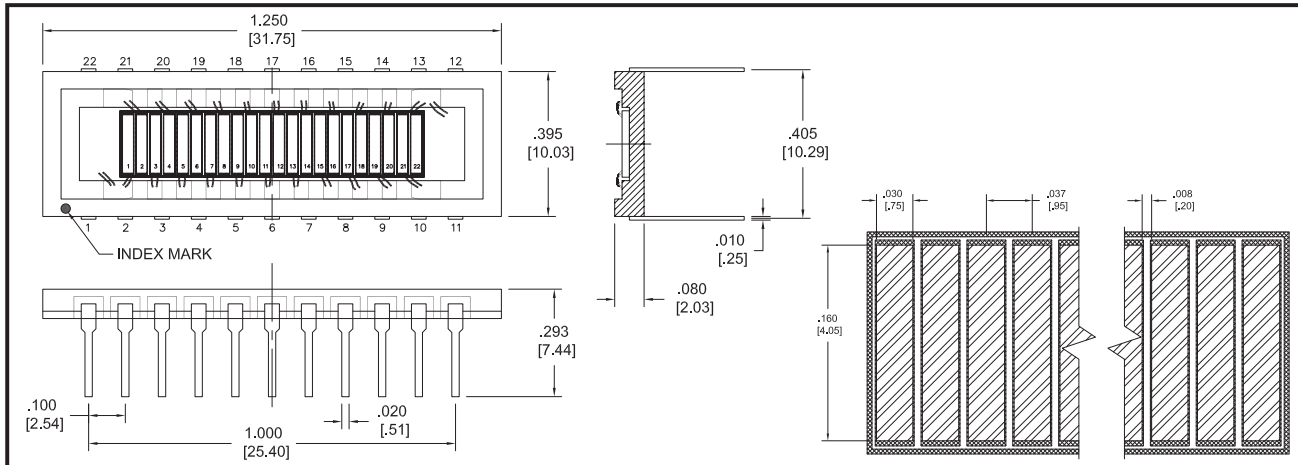

Dimensions are in inch [metric] units.

**FEATURES**

- 22 pin dual in-line package
- Ideal for electron detection
- 100% internal QE

**ELECTRO-OPTICAL CHARACTERISTICS AT 25°C (Per Element)**

PARAMETERS	TEST CONDITIONS	MIN	TYP	MAX	UNITS
Active Area	0.75mm x 4.1mm		3		mm <sup>2</sup>
Responsivity, $\mathcal{R}$	(see graphs on next page)				A/W
Reverse Breakdown Voltage, $V_R$	$I_R = 1\mu A$		25		Volts
Capacitance, C	$V_R = 0V$			40	pF
Rise Time	$V_R = 0V$			200	nsec
Shunt Resistance (per element)	$V_f = \pm 10mV$	100			MOhms

**THERMAL PARAMETERS**

STORAGE AND OPERATING TEMPERATURE RANGE	
Ambient <sup>1</sup>	-10° TO 40°C <sup>1</sup>
Nitrogen or Vacuum	-20°C TO 80°C
Maximum Junction Temperature	70°C
Lead Soldering Temperature <sup>2</sup>	260°C

<sup>1</sup>Temperatures exceeding these parameters may create oxide growth on the active area. Over time responsivity to low energy radiation and wavelengths below 150nm will be compromised.

<sup>2</sup>0.080" from case for 10 seconds.

Shipped with temporary cover to protect photodiode and wire bond.  
Review Opto Diode "Handling Precautions for IRD Detectors" prior to removing cover.



750 Mitchell Road, Newbury Park, California 91320  
Phone: (805) 499-0335, Fax: (805) 499-8108  
Email: sales@optodiode.com, Website: www.optodiode.com

