



Chipsmall Limited consists of a professional team with an average of over 10 year of expertise in the distribution of electronic components. Based in Hongkong, we have already established firm and mutual-benefit business relationships with customers from,Europe,America and south Asia,supplying obsolete and hard-to-find components to meet their specific needs.

With the principle of "Quality Parts,Customers Priority,Honest Operation,and Considerate Service",our business mainly focus on the distribution of electronic components. Line cards we deal with include Microchip,ALPS,ROHM,Xilinx,Pulse,ON,Everlight and Freescale. Main products comprise IC,Modules,Potentiometer,IC Socket,Relay,Connector.Our parts cover such applications as commercial,industrial, and automotives areas.

We are looking forward to setting up business relationship with you and hope to provide you with the best service and solution. Let us make a better world for our industry!



Contact us

Tel: +86-755-8981 8866 Fax: +86-755-8427 6832

Email & Skype: info@chipsmall.com Web: www.chipsmall.com

Address: A1208, Overseas Decoration Building, #122 Zhenhua RD., Futian, Shenzhen, China



1A ULTRA LOW DROPOUT LINEAR REGULATOR

Description

The AZ2940 is a low dropout three-terminal regulator with a typical dropout of 280mV at 1A output current.

The AZ2940 provides current limit and thermal shutdown. On-chip thermal shutdown provides protection against any combination of high current and ambient temperature that would create excessive junction temperatures.

The AZ2940 has 1.2V, 1.8V, 2.5V, 3.3V and 5.0V versions.

The AZ2940 series is available in the industry standard TO-220-3, TO-220F-3, TO-263-3, TO-252-2 (3), TO-252-2 (4), TO-252-2 (5) and SOT-223 power packages. (Detailed information please refer to pages 13, 14)

Applications

- LCD TV
- Set Top Box
- LCD Monitor
- SMPS Post Regulator
- Laptop, Palmtop and Notebook
- Portable Instrumentation
- USB Power Supply

- Notes:
1. EU Directive 2002/95/EC (RoHS) & 2011/65/EU (RoHS 2) compliant. All applicable RoHS exemptions applied.
 2. See http://www.diodes.com/quality/lead_free.html for more information about Diodes Incorporated's definitions of Halogen- and Antimony-free, "Green" and Lead-free.
 3. Halogen- and Antimony-free "Green" products are defined as those which contain <900ppm bromine, <900ppm chlorine (<1500ppm total Br + Cl) and <1000ppm antimony compounds.

Features

- Minimum Guaranteed Output Current: 1A
- Dropout Voltage at $I_{OUT} = 1A$: 280mV Typ. (Except 1.2V and 1.8V Versions)
- Output Accuracy: $\pm 1\%$
- Low Ground Current
- Internal Current Limit and Thermal Protection
- Reversed-battery and Reversed-lead Insertion Protection
- Fast Transient Response
- TO-220-3, TO-263-3, TO-252-2 (3), TO-252-2 (4), TO-252-2 (5)
 - **Lead-Free Finish; RoHS Compliant (Notes 1 & 2)**
- Available in "Green" Packages: TO-220-3, TO-220F-3, TO-263-3, TO-252-2 (3), TO-252-2 (4), TO-252-2 (5) and SOT-223
 - **Lead-Free Finish; RoHS Compliant (Notes 1 & 2)**
 - **Halogen and Antimony Free. "Green" Device (Note 3)**

Pin Assignments

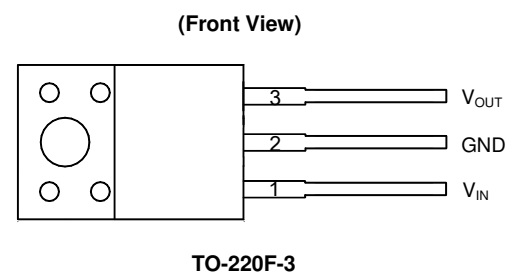
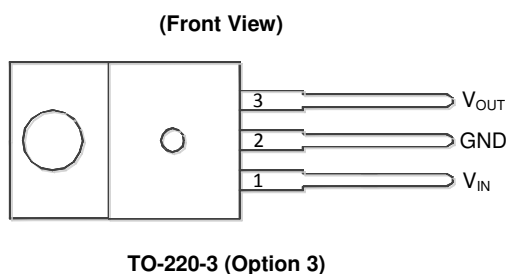
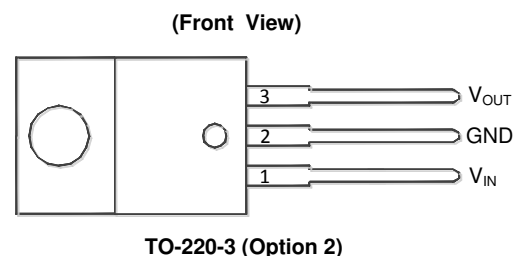
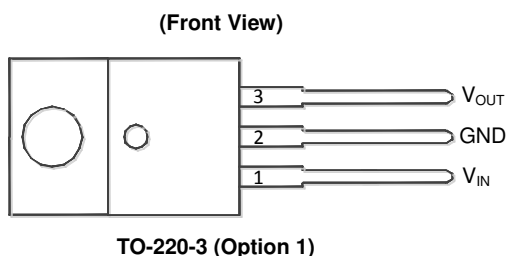

Pin Assignments (Cont.)

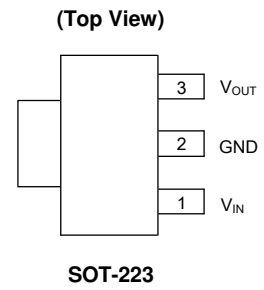
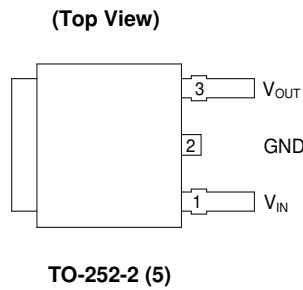
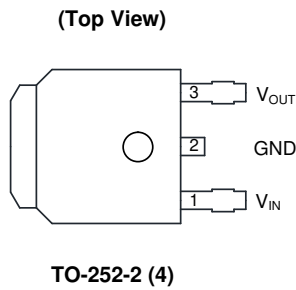
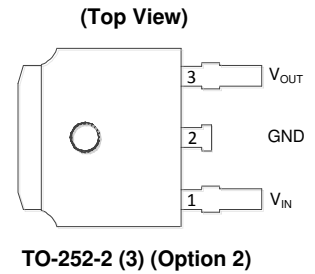
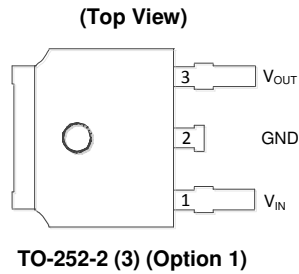
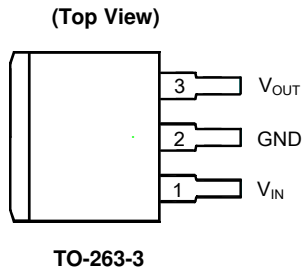

Typical Applications Circuit (Note 4)

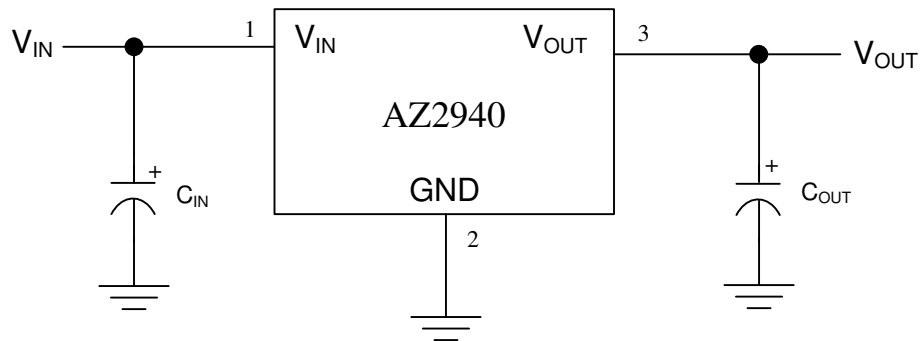

Note 4: C_{IN} is required if regulator is located far from power supply filter and is recommended to be $0.47\mu F$ or greater. To maintain stability, C_{OUT} is recommended to be $2.2\mu F$ or greater. The ESR of this capacitor is critical, please see curve.

Pin Description

Pin Number	Pin Name	Function
1	V_{IN}	Unregulated Input
2	GND	Ground pin. This pin and TAB are internally connected
3	V_{OUT}	Regulated Output

Functional Block Diagram

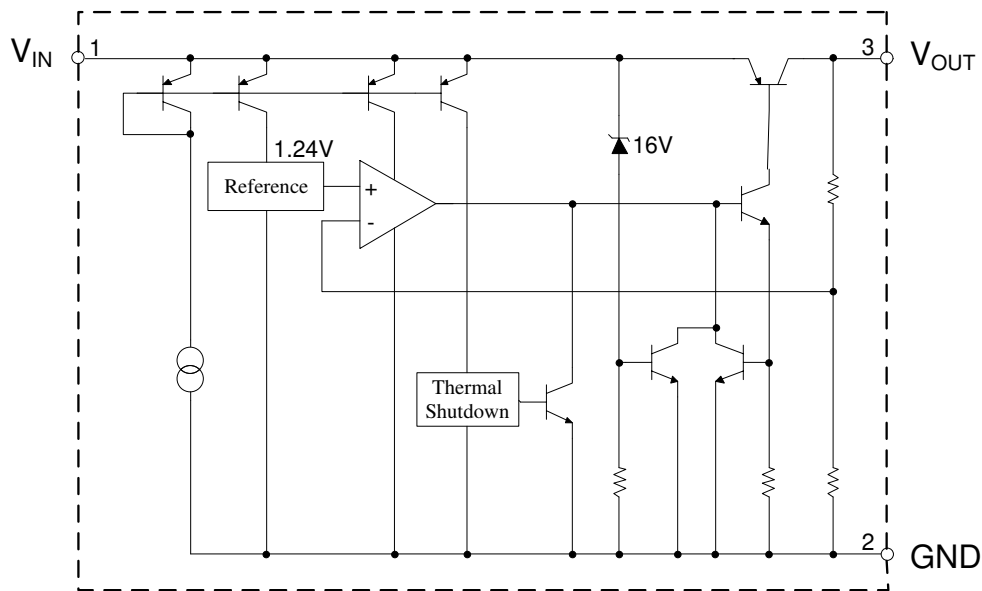

Absolute Maximum Ratings (Note 5)

Symbol	Parameter	Rating		Unit
V _{IN}	Input Voltage	16		V
T _J	Operating Junction Temperature	+150		°C
T _{STG}	Storage Temperature Range	-65 to +150		°C
T _{LEAD}	Lead Temperature (Soldering, 10sec)	+260		°C
θ _{JA}	Thermal Resistance (Junction to Ambient)	TO-220-3/TO-220F-3	60	°C/W
		TO-263-3	60	
		TO-252-2 (3)/(4)/(5)	100	
		SOT-223	120	
ESD	ESD (Human Body Model)	5000		V
ESD	ESD (Machine Model)	300		V

Note 5: Stresses greater than those listed under “Absolute Maximum Ratings” may cause permanent damage to the device. These are stress ratings only, and functional operation of the device at these or any other conditions beyond those indicated under “Recommended Operating Conditions” is not implied. Exposure to “Absolute Maximum Ratings” for extended periods may affect device reliability.

Recommended Operating Conditions

Symbol	Parameter	Min	Max	Unit
V _{IN}	Input Voltage	2.5	13.2	V
T _J	Operating Junction Temperature	-40	+125	°C

Electrical Characteristics

AZ2940-1.2 Electrical Characteristics

(Operating Conditions: $V_{IN} = 2.5V$, $I_{OUT} = 10mA$, $C_{IN} = 10\mu F$, $C_{OUT} = 10\mu F$, $T_J = +25^\circ C$, unless otherwise specified. The **Boldface** applies over $-40^\circ C$ to $+125^\circ C$)

Symbol	Parameter	Condition	Min	Typ	Max	Unit	
V_{OUT}	Output Voltage	$I_{OUT} = 10mA$	1.188	1.2	1.212	V	
		$10mA \leq I_{OUT} \leq 1A$, $2.5V \leq V_{IN} \leq 13.2V$	1.176	1.2	1.224	V	
V_{RLINE}	Line Regulation	$I_{OUT} = 10mA$, $2.5V \leq V_{IN} \leq 13.2V$	–	3.6	18	mV	
V_{RLOAD}	Load Regulation	$V_{IN} = 2.5V$, $10mA \leq I_{OUT} \leq 1A$	–	5.4	27	mV	
$\Delta V_{OUT}/\Delta T$	Output Voltage Temperature Coefficient	$I_{OUT} = 10mA$	–	–	180	$\mu V/^\circ C$	
I_{GND}	Ground Current	$V_{IN} = 2.5V$	$I_{OUT} = 750mA$	–	12	25	mA
			$I_{OUT} = 1A$	–	18	–	mA
I_{SC}	Short Circuit Current	$V_{OUT} = 0V$ (Note 6)	1.5	2.2	–	A	
$I_{LOAD(MIN)}$	Minimum Load Current	–	–	1	5	mA	
–	Output Noise Voltage (rms)	10Hz to 100kHz, $I_{OUT} = 100mA$, $C_{OUT} = 10\mu F$	–	400	–	μV	
θ_{JC}	Thermal Resistance	TO-252-2 (3)/(4)/(5)	–	7.8	–	$^\circ C/W$	
		SOT-223	–	29.7	–		

Note 6: $V_{IN} = V_{OUT(NOMINAL)} + 1V$.

Electrical Characteristics (Cont.)

AZ2940-1.8 Electrical Characteristics

(Operating Conditions: $V_{IN} = 2.8V$, $I_{OUT} = 10mA$, $C_{IN} = 10\mu F$, $C_{OUT} = 10\mu F$, $T_J = +25^\circ C$, unless otherwise specified. The **Boldface** applies over $-40^\circ C$ to $+125^\circ C$)

Symbol	Parameter	Condition	Min	Typ	Max	Unit	
V_{OUT}	Output Voltage	$I_{OUT} = 10mA$	1.782	1.8	1.818	V	
		$10mA \leq I_{OUT} \leq 1A$, $2.8V \leq V_{IN} \leq 13.2V$	1.764	1.8	1.836	V	
V_{RLINE}	Line Regulation	$I_{OUT} = 10mA$, $2.8V \leq V_{IN} \leq 13.2V$	–	3.6	18	mV	
V_{RLOAD}	Load Regulation	$V_{IN} = 2.8V$, $10mA \leq I_{OUT} \leq 1A$	–	5.4	27	mV	
$\Delta V_{OUT}/\Delta T$	Output Voltage Temperature Coefficient	$I_{OUT} = 10mA$	–	36	180	$\mu V/^\circ C$	
V_{DROP}	Dropout Voltage (Note 7)	$\Delta V_{OUT} = 1\%$	$I_{OUT} = 100mA$	–	290	500	mV
			$I_{OUT} = 1A$	–	330	750	mV
I_{GND}	Ground Current	$V_{IN} = 2.8V$	$I_{OUT} = 750mA$	–	12	25	mA
			$I_{OUT} = 1A$	–	18	–	mA
I_{SC}	Short Circuit Current	$V_{OUT} = 0V$ (Note 6)	1.5	2.2	–	A	
$I_{LOAD (MIN)}$	Minimum Load Current	–	–	1	5	mA	
–	Output Noise Voltage (rms)	10Hz to 100kHz, $I_{OUT} = 100mA$, $C_{OUT} = 10\mu F$	–	400	–	μV	
θ_{JC}	Thermal Resistance	TO-252-2 (3)/(4)/(5)	–	7.8	–	$^\circ C/W$	
		SOT-223	–	29.7	–		

Notes: 6. $V_{IN} = V_{OUT(NOMINAL)} + 1V$.

7. Dropout voltage is defined as the input-to-output differential when the output voltage drops to 99% of its nominal value which is measured at $V_{OUT} + 1V$ applied to V_{IN} . In application, V_{IN} should be no less than 2.5V.

Electrical Characteristics (Cont.)

AZ2940-2.5 Electrical Characteristics

(Operating Conditions: $V_{IN} = 3.5V$, $I_{OUT} = 10mA$, $C_{IN} = 10\mu F$, $C_{OUT} = 10\mu F$, $T_J = +25^\circ C$, unless otherwise specified. The **Boldface** applies over $-40^\circ C$ to $+125^\circ C$)

Symbol	Parameter	Condition	Min	Typ	Max	Unit	
V_{OUT}	Output Voltage	$I_{OUT} = 10mA$	2.475	2.5	2.525	V	
		$10mA \leq I_{OUT} \leq 1A$, $3.5V \leq V_{IN} \leq 13.2V$	2.45	2.5	2.55	V	
V_{RLINE}	Line Regulation	$I_{OUT} = 10mA$, $3.5V \leq V_{IN} \leq 13.2V$	–	5.0	25	mV	
V_{RLOAD}	Load Regulation	$V_{IN} = 3.5V$, $10mA \leq I_{OUT} \leq 1A$	–	7.5	37.5	mV	
$\Delta V_{OUT}/\Delta T$	Output Voltage Temperature Coefficient	$I_{OUT} = 10mA$	–	50	250	$\mu V/^\circ C$	
V_{DROP}	Dropout Voltage (Note 8)	$\Delta V_{OUT} = 1\%$	$I_{OUT} = 100mA$	–	70	200	mV
			$I_{OUT} = 1A$	–	280	550	mV
I_{GND}	Ground Current	$V_{IN} = 3.5V$	$I_{OUT} = 750mA$	–	12	25	mA
			$I_{OUT} = 1A$	–	18	–	mA
I_{SC}	Short Circuit Current	$V_{OUT} = 0V$ (Note 6)	1.5	2.2	–	A	
$I_{LOAD(MIN)}$	Minimum Load Current	–	–	1	5	mA	
–	Output Noise Voltage (rms)	10Hz to 100kHz, $I_{OUT} = 100mA$, $C_{OUT} = 10\mu F$	–	400	–	μV	
θ_{JC}	Thermal Resistance	TO-252-2 (3)/(4)/(5)	–	7.8	–	$^\circ C/W$	
		SOT-223	–	29.7	–		

- Notes:
- 6. $V_{IN} = V_{OUT(NOMINAL)} + 1V$.
 - 8. Dropout voltage is defined as the input-to-output differential when the output voltage drops to 99% of its nominal value which is measured at $V_{OUT} + 1V$ applied to V_{IN} .

Electrical Characteristics (Cont.)

AZ2940-3.3 Electrical Characteristics

(Operating Conditions: $V_{IN} = 4.3V$, $I_{OUT} = 10mA$, $C_{IN} = 10\mu F$, $C_{OUT} = 10\mu F$, $T_J = +25^\circ C$, unless otherwise specified. The **Boldface** applies over -40°C to +125°C)

Symbol	Parameter	Condition	Min	Typ	Max	Unit	
V_{OUT}	Output Voltage	$I_{OUT} = 10mA$	3.27	3.3	3.33	V	
		$10mA \leq I_{OUT} \leq 1A$, $4.3V \leq V_{IN} \leq 13.2V$	3.23	3.3	3.37	V	
V_{RLINE}	Line Regulation	$I_{OUT} = 10mA$, $4.3V \leq V_{IN} \leq 13.2V$	-	6.6	33	mV	
V_{RLOAD}	Load Regulation	$V_{IN} = 4.3V$, $10mA \leq I_{OUT} \leq 1A$	-	9.9	50	mV	
$\Delta V_{OUT}/\Delta T$	Output Voltage Temperature Coefficient	$I_{OUT} = 10mA$	-	66	330	$\mu V/^\circ C$	
V_{DROP}	Dropout Voltage (Note 8)	$\Delta V_{OUT} = 1\%$	$I_{OUT} = 100mA$	-	70	200	mV
			$I_{OUT} = 1A$	-	280	550	mV
I_{GND}	Ground Current	$V_{IN} = 4.3V$	$I_{OUT} = 750mA$	-	12	25	mA
			$I_{OUT} = 1A$	-	18	-	mA
I_{SC}	Short Circuit Current	$V_{OUT} = 0V$ (Note 6)	1.5	2.2	-	A	
$I_{LOAD(MIN)}$	Minimum Load Current	-	-	1	5	mA	
-	Output Noise Voltage (rms)	10Hz to 100kHz, $I_{OUT} = 100mA$, $C_{OUT} = 10\mu F$	-	400	-	μV	
θ_{JC}	Thermal Resistance	TO-220-3	-	4.4	-	$^\circ C/W$	
		TO-263-3	-	4.4	-		
		TO-252-2 (3)/(4)/(5)	-	7.8	-		
		SOT-223	-	29.7	-		

Notes: 6. $V_{IN} = V_{OUT(NOMINAL)} + 1V$.

8. Dropout voltage is defined as the input-to-output differential when the output voltage drops to 99% of its nominal value which is measured at $V_{OUT} + 1V$ applied to V_{IN} .

Electrical Characteristics (Cont.)

AZ2940-5.0 Electrical Characteristics

(Operating Conditions: $V_{IN} = 6V$, $I_{OUT} = 10mA$, $C_{IN} = 10\mu F$, $C_{OUT} = 10\mu F$, $T_J = +25^\circ C$, unless otherwise specified. The **Boldface** applies over $-40^\circ C$ to $+125^\circ C$)

Symbol	Parameter	Condition	Min	Typ	Max	Unit	
V_{OUT}	Output Voltage	$I_{OUT} = 10mA$	4.95	5.0	5.05	V	
		$10mA \leq I_{OUT} \leq 1A$, $6V \leq V_{IN} \leq 13.2V$	4.90	5.0	5.10	V	
V_{RLINE}	Line Regulation	$I_{OUT} = 10mA$, $6V \leq V_{IN} \leq 13.2V$	–	10	50	mV	
V_{RLOAD}	Load Regulation	$V_{IN} = 6V$, $10mA \leq I_{OUT} \leq 1A$	–	15	75	mV	
$\Delta V_{OUT}/\Delta T$	Output Voltage Temperature Coefficient	$I_{OUT} = 10mA$	–	100	500	$\mu V/^\circ C$	
V_{DROP}	Dropout Voltage (Note 8)	$\Delta V_{OUT} = 1\%$	$I_{OUT} = 100mA$	–	70	200	mV
			$I_{OUT} = 1A$	–	280	550	mV
I_{GND}	Ground Current	$V_{IN} = 6V$	$I_{OUT} = 750mA$	–	12	25	mA
			$I_{OUT} = 1A$	–	18	–	mA
I_{SC}	Short Circuit Current	$V_{OUT} = 0V$ (Note 6)	1.5	2.2	–	A	
$I_{LOAD(MIN)}$	Minimum Load Current	–	–	1	5	mA	
–	Output Noise Voltage (rms)	10Hz to 100kHz, $I_{OUT} = 100mA$, $C_{OUT} = 10\mu F$	–	400	–	μV	
θ_{JC}	Thermal Resistance	TO-220-3/TO-220F-3	–	4.4	–	$^\circ C/W$	
		TO-263-3	–	4.4	–		
		TO-252-2 (3)/(4)/(5)	–	7.8	–		
		SOT-223	–	29.7	–		

Notes: 6. $V_{IN} = V_{OUT(NOMINAL)} + 1V$.

8. Dropout voltage is defined as the input-to-output differential when the output voltage drops to 99% of its nominal value which is measured at $V_{OUT} + 1V$ applied to V_{IN} .

Performance Characteristics

Line Regulation

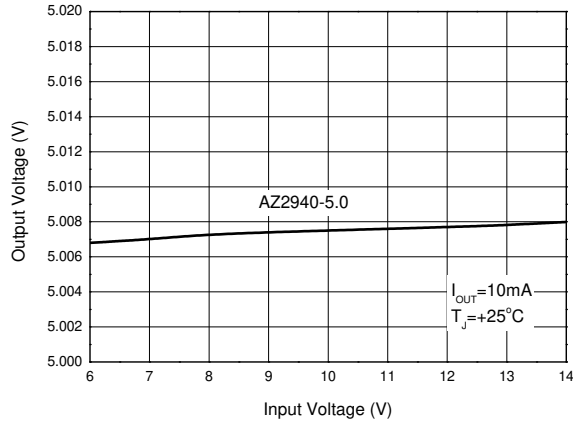

Load Regulation

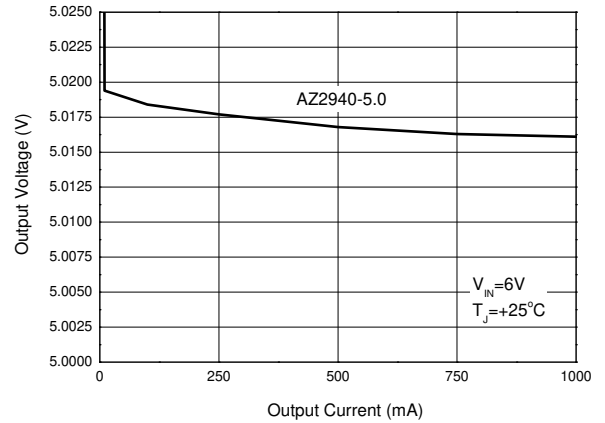

Ground Current vs. Output Current

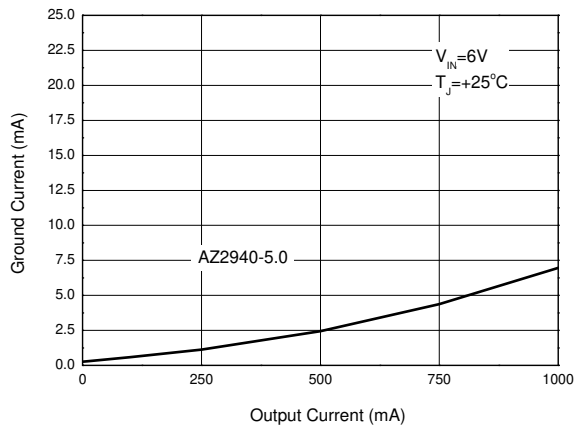

Ground Current vs. Input Voltage

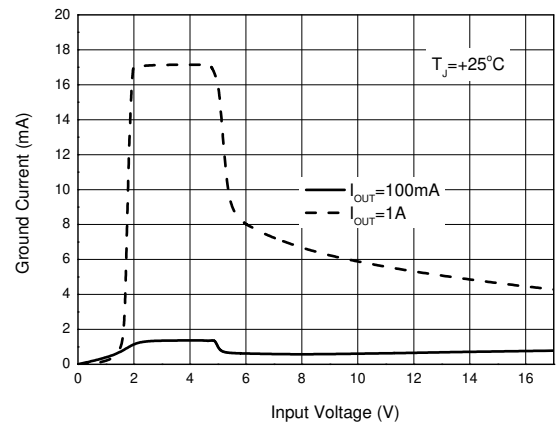

Dropout Voltage vs. Output Current

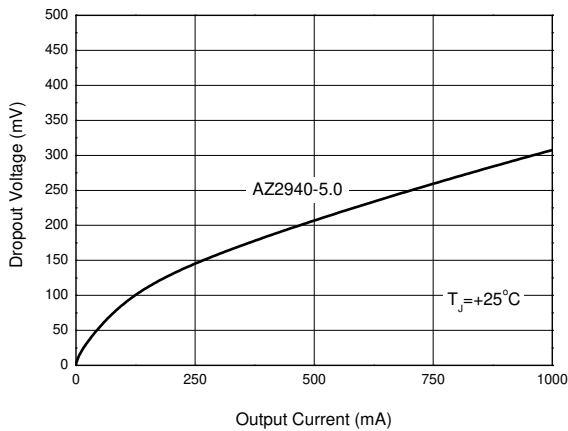

Ground Current vs. Junction Temperature

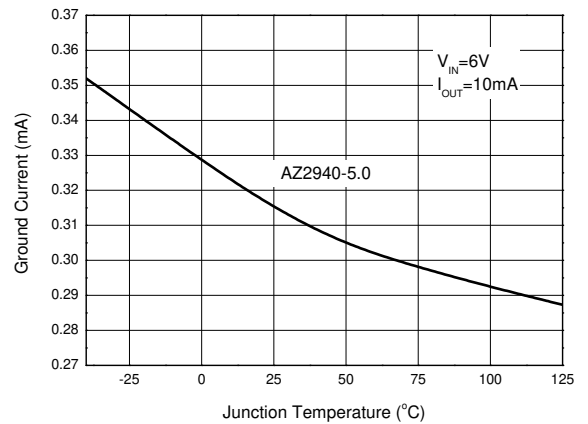

Performance Characteristics (Cont.)

Ground Current vs. Junction Temperature

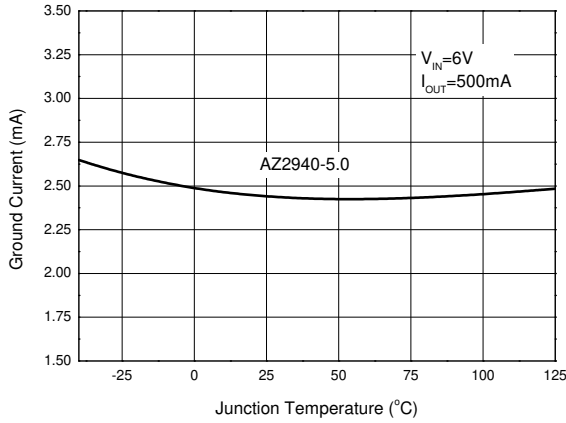

Ground Current vs. Junction Temperature

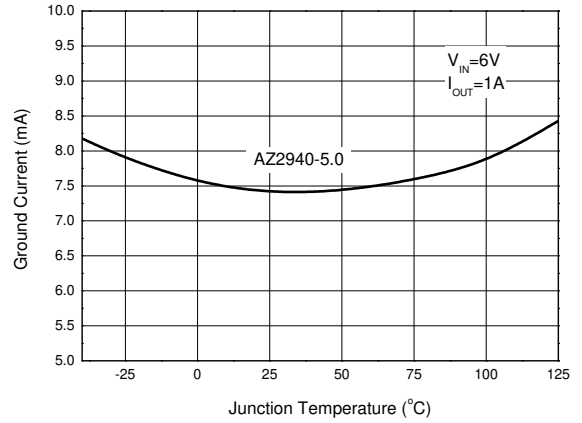

Dropout Voltage vs. Junction Temperature

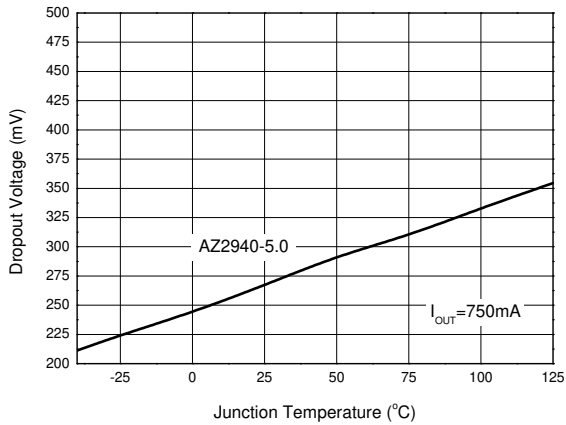

Dropout Voltage vs. Junction Temperature

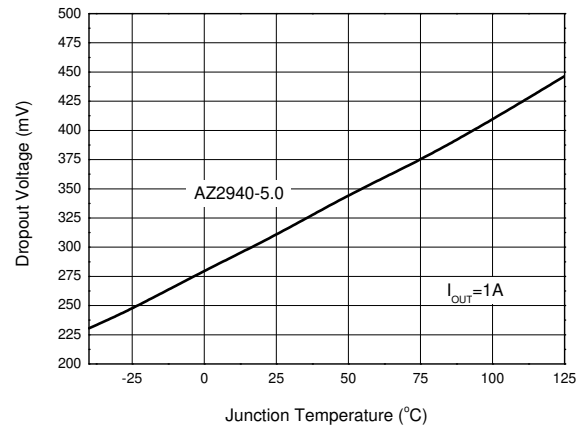

Output Voltage vs. Junction Temperature

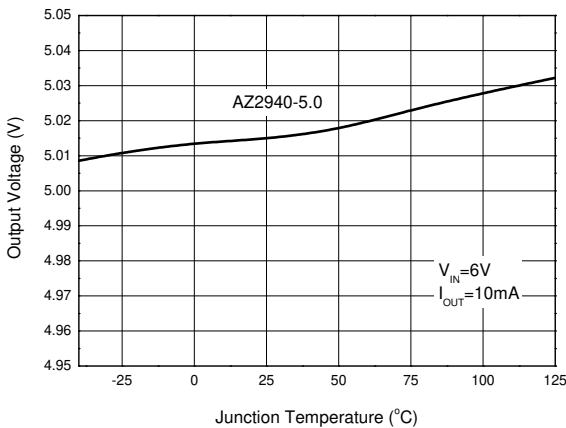

Output Capacitor ESR vs. Output Current

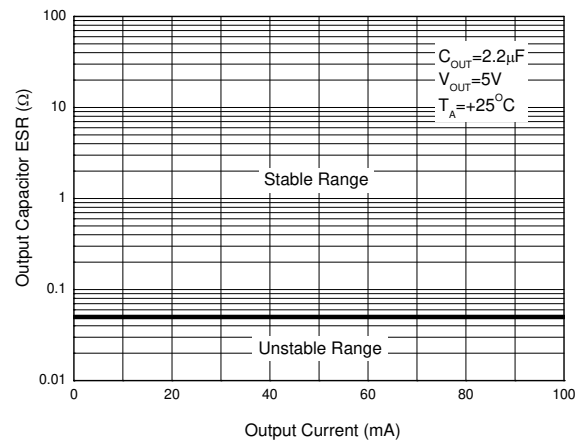

Performance Characteristics (Cont.)

Output Capacitor ESR vs. Output Current

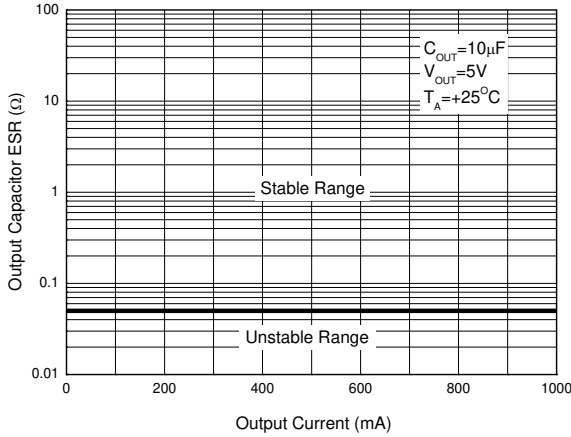

Load Transient

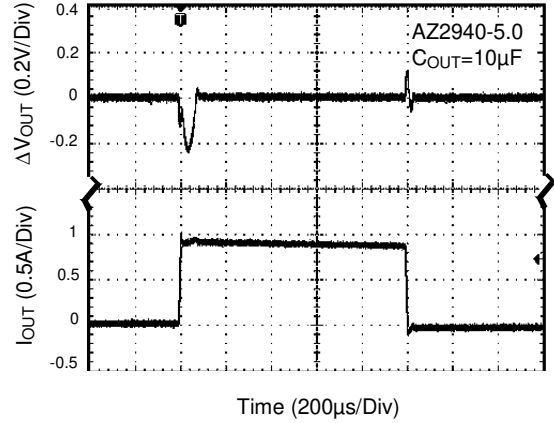

Load Transient

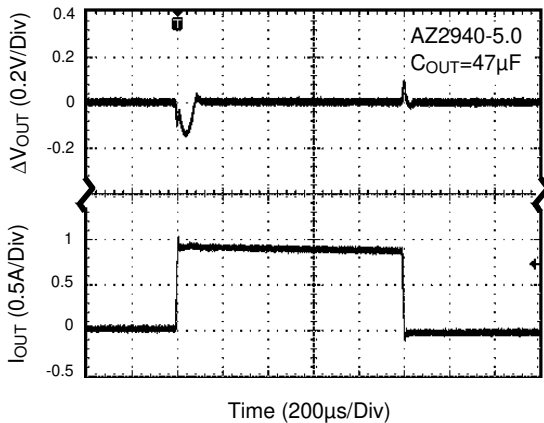

Line Transient

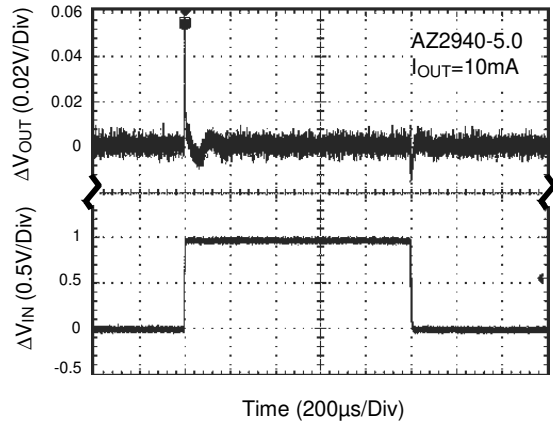

Power Dissipation vs. Case Temperature

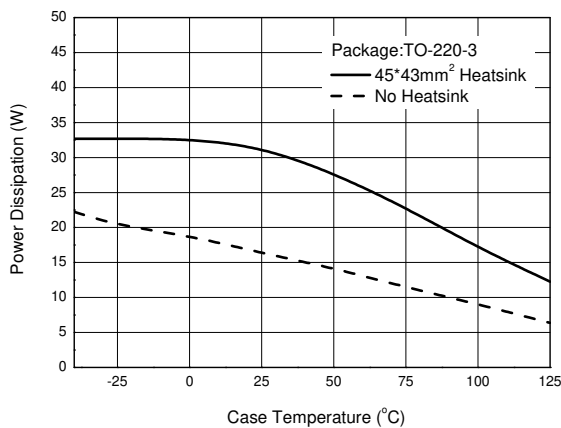

Power Dissipation vs. Case Temperature

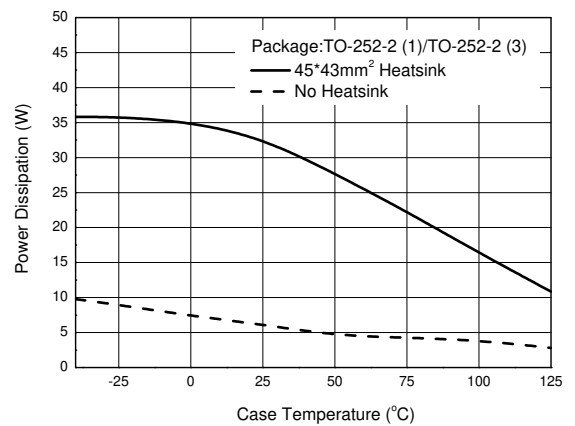

Performance Characteristics (Cont.)

Power Dissipation vs. Case Temperature

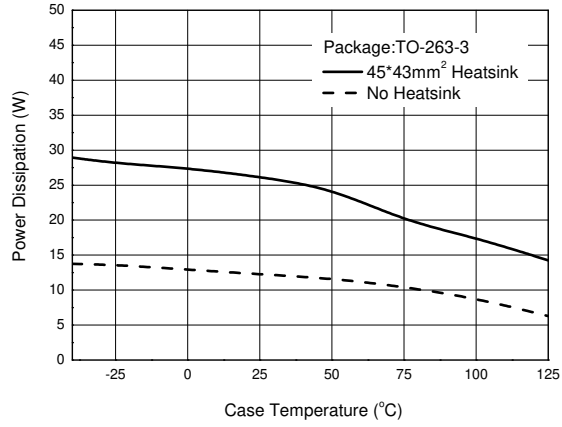

Ordering Information

AZ2940 XX - XX XX XX

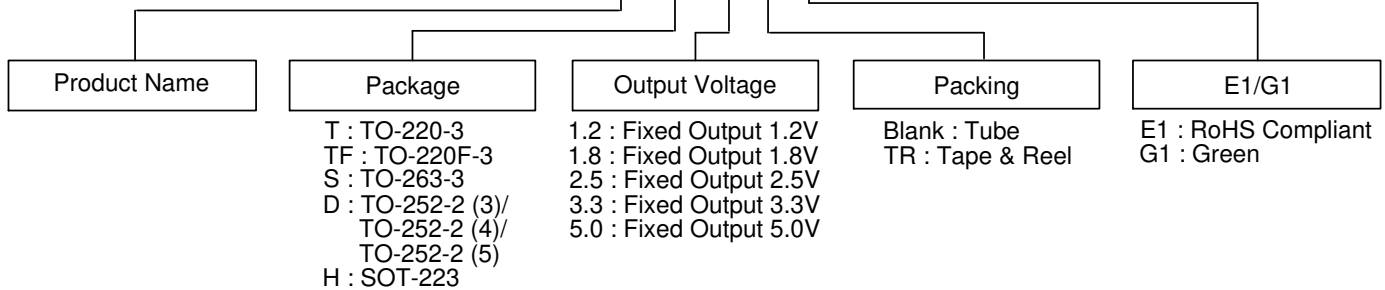

Package	Temperature Range	Part Number		Marking ID		Packing
		RoHS Compliant	Green	RoHS Compliant	Green	
TO-220-3	-40 to +125°C	AZ2940T-3.3E1	AZ2940T-3.3G1	AZ2940T-3.3E1	AZ2940T-3.3G1	1000/Tube
		AZ2940T-5.0E1	AZ2940T-5.0G1	AZ2940T-5.0E1	AZ2940T-5.0G1	1000/Tube
TO-220F-3	-40 to +125°C	-	AZ2940TF-5.0G1	-	AZ2940TF-5.0G1	1000/Tube
TO-263-3	-40 to +125°C	AZ2940S-3.3E1	AZ2940S-3.3G1	AZ2940S-3.3E1	AZ2940S-3.3G1	1000/Tube
		AZ2940S-3.3TRE1	AZ2940S-3.3TRG1	AZ2940S-3.3E1	AZ2940S-3.3G1	2500/Tape & Reel
		AZ2940S-5.0E1	AZ2940S-5.0G1	AZ2940S-5.0E1	AZ2940S-5.0G1	1000/Tube
		AZ2940S-5.0TRE1	AZ2940S-5.0TRG1	AZ2940S-5.0E1	AZ2940S-5.0G1	2500/Tape & Reel
TO-252-2 (3)/ TO-252-2 (4)/ TO-252-2(5)	-40 to +125°C	-	AZ2940D-1.2G1	-	AZ2940D-1.2G1	1000/Tube
		-	AZ2940D-1.2TRG1	-	AZ2940D-1.2G1	2500/Tape & Reel
		AZ2940D-1.8E1	AZ2940D-1.8G1	AZ2940D-1.8E1	AZ2940D-1.8G1	1000/Tube
		AZ2940D-1.8TRE1	AZ2940D-1.8TRG1	AZ2940D-1.8E1	AZ2940D-1.8G1	2500/Tape & Reel
		AZ2940D-2.5E1	AZ2940D-2.5G1	AZ2940D-2.5E1	AZ2940D-2.5G1	1000/Tube
		AZ2940D-2.5TRE1	AZ2940D-2.5TRG1	AZ2940D-2.5E1	AZ2940D-2.5G1	2500/Tape & Reel
		AZ2940D-3.3E1	AZ2940D-3.3G1	AZ2940D-3.3E1	AZ2940D-3.3G1	1000/Tube
		AZ2940D-3.3TRE1	AZ2940D-3.3TRG1	AZ2940D-3.3E1	AZ2940D-3.3G1	2500/Tape & Reel
		AZ2940D-5.0E1	AZ2940D-5.0G1	AZ2940D-5.0E1	AZ2940D-5.0G1	1000/Tube
		AZ2940D-5.0TRE1	AZ2940D-5.0TRG1	AZ2940D-5.0E1	AZ2940D-5.0G1	2500/Tape & Reel

Ordering Information (Cont.)



Package	Temperature Range	Part Number		Marking ID		Packing
		RoHS Compliant	Green	RoHS Compliant	Green	
SOT-223	-40 to +125°C	-	AZ2940H-1.2TRG1	-	GH12B	2500/Tape & Reel
		-	AZ2940H-1.8TRG1	-	GH12F	2500/Tape & Reel
		-	AZ2940H-2.5TRG1	-	GH12G	2500/Tape & Reel
		-	AZ2940H-3.3TRG1	-	GH12H	2500/Tape & Reel
		-	AZ2940H-5.0TRG1	-	GH12J	2500/Tape & Reel

Marking Information

(1) TO-220-3

(Front View)

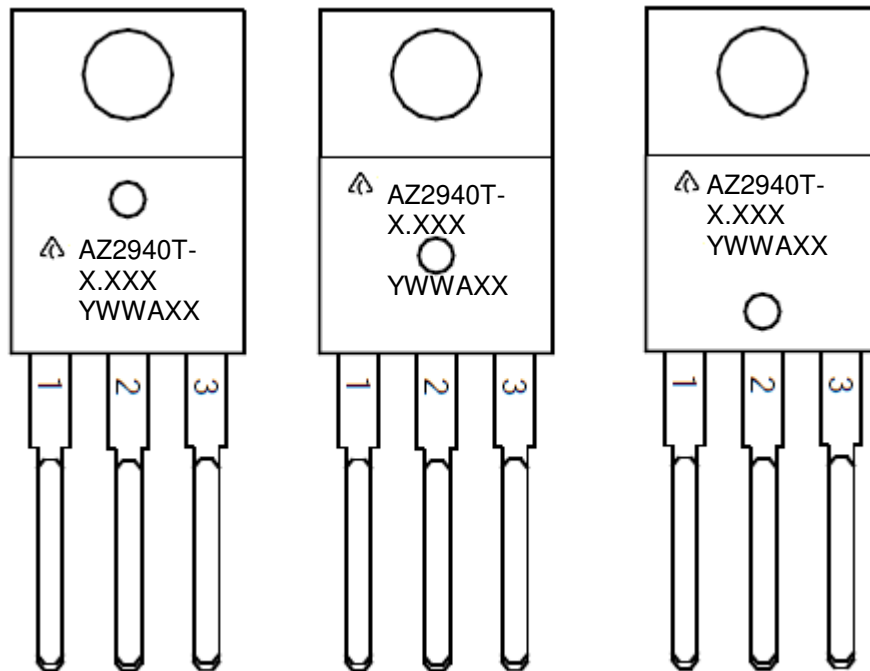

First and Second Lines: Logo and Marking ID
(See Ordering Information)
Third Line: Date Code
Y: Year
WW: Work Week of Molding
A: Assembly House Code
XX: Internal Code

Marking Information (Cont.)

(2) TO-220F-3

(Front View)

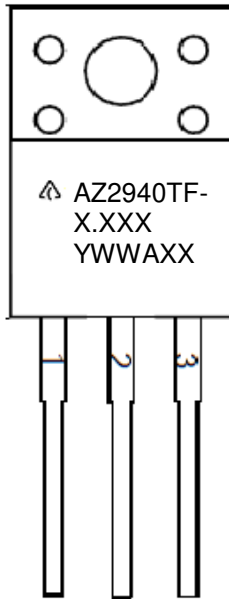

First and Second Lines: Logo and Marking ID
(See Ordering Information)
Third Line: Date Code
Y: Year
WW: Work Week of Molding
A: Assembly House Code
XX: Internal Code

(3) TO-252-2(3)/(4)/(5)

(Top View)

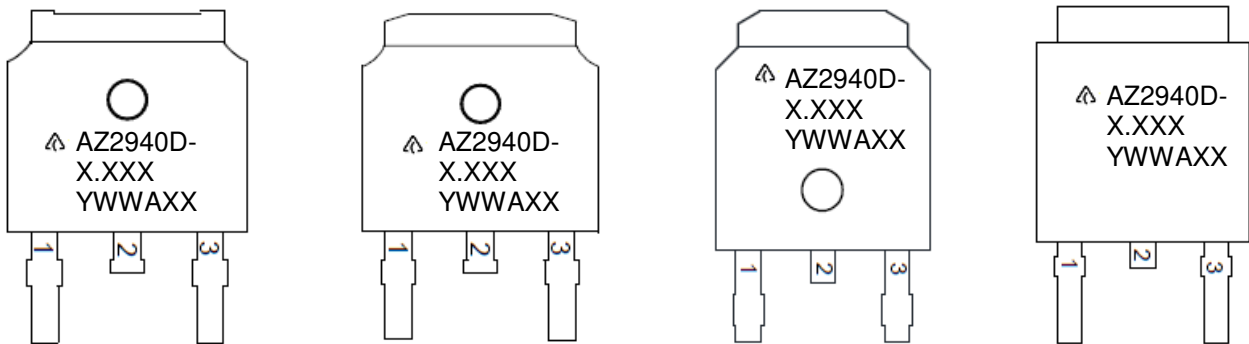

First and Second Lines: Logo and Marking ID
(See Ordering Information)
Third Line: Date Code
Y: Year
WW: Work Week of Molding
A: Assembly House Code
XX: Internal Code

Marking Information (Cont.)

(4) TO-263-3

(Top View)

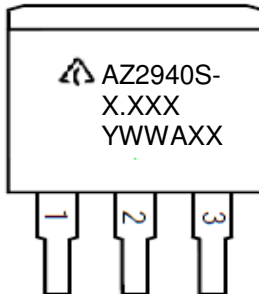

First and Second Lines: Logo and Marking ID
(See Ordering Information)
Third Line: Date Code
Y: Year
WW: Work Week of Molding
A: Assembly House Code
XX: Internal Code

(5) SOT-223

(Top View)



First Line: Logo and Marking ID
(See Ordering Information)
Second Line: Date Code
Y: Year
WW: Work Week of Molding
A: Assembly House Code
XX: Internal Code

Package Outline Dimensions (All dimensions in mm(inch).)

(1) Package Type: TO-220-3

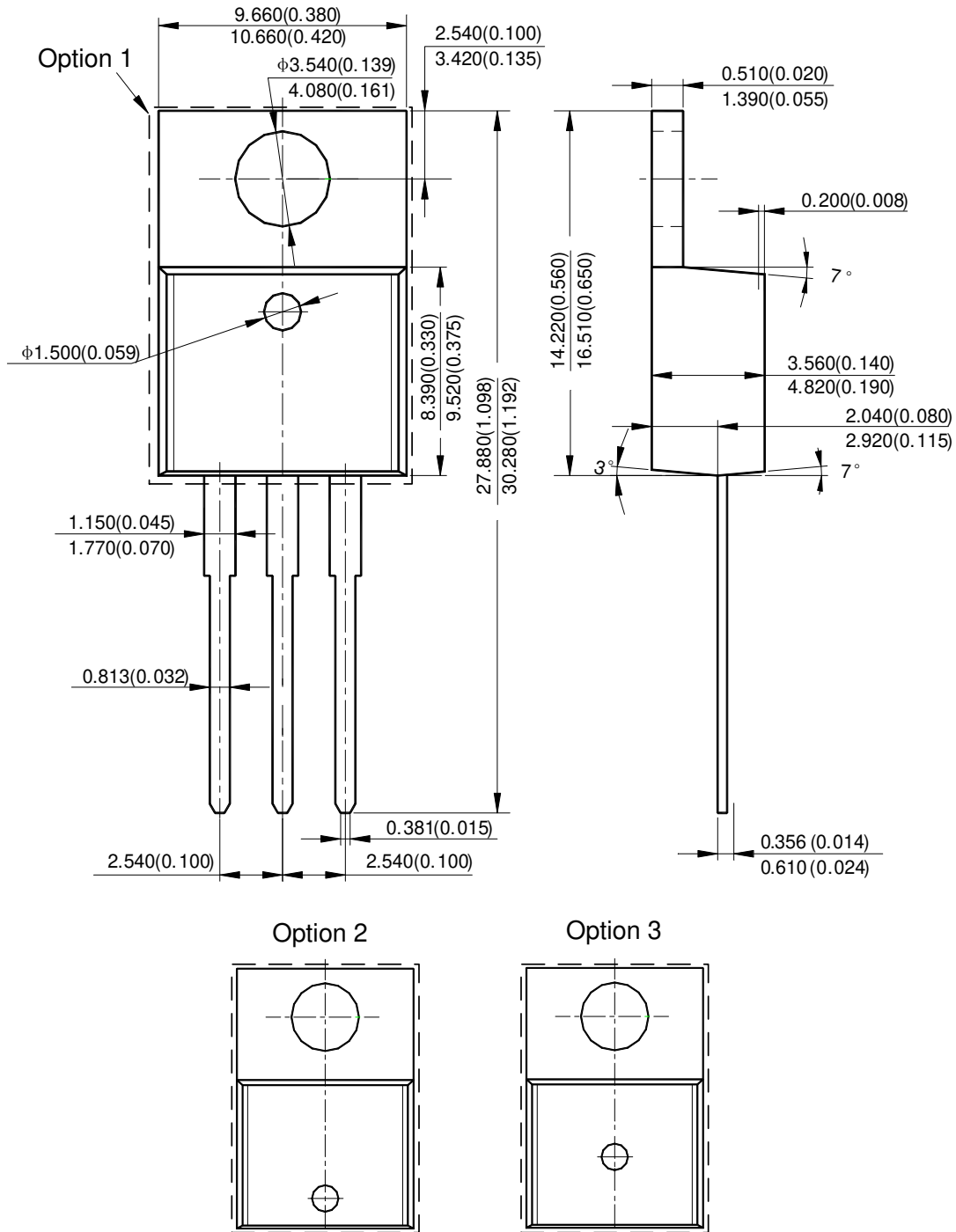

Package Outline Dimensions (Cont. All dimensions in mm(inch).)

(2) Package Type: TO-220F-3

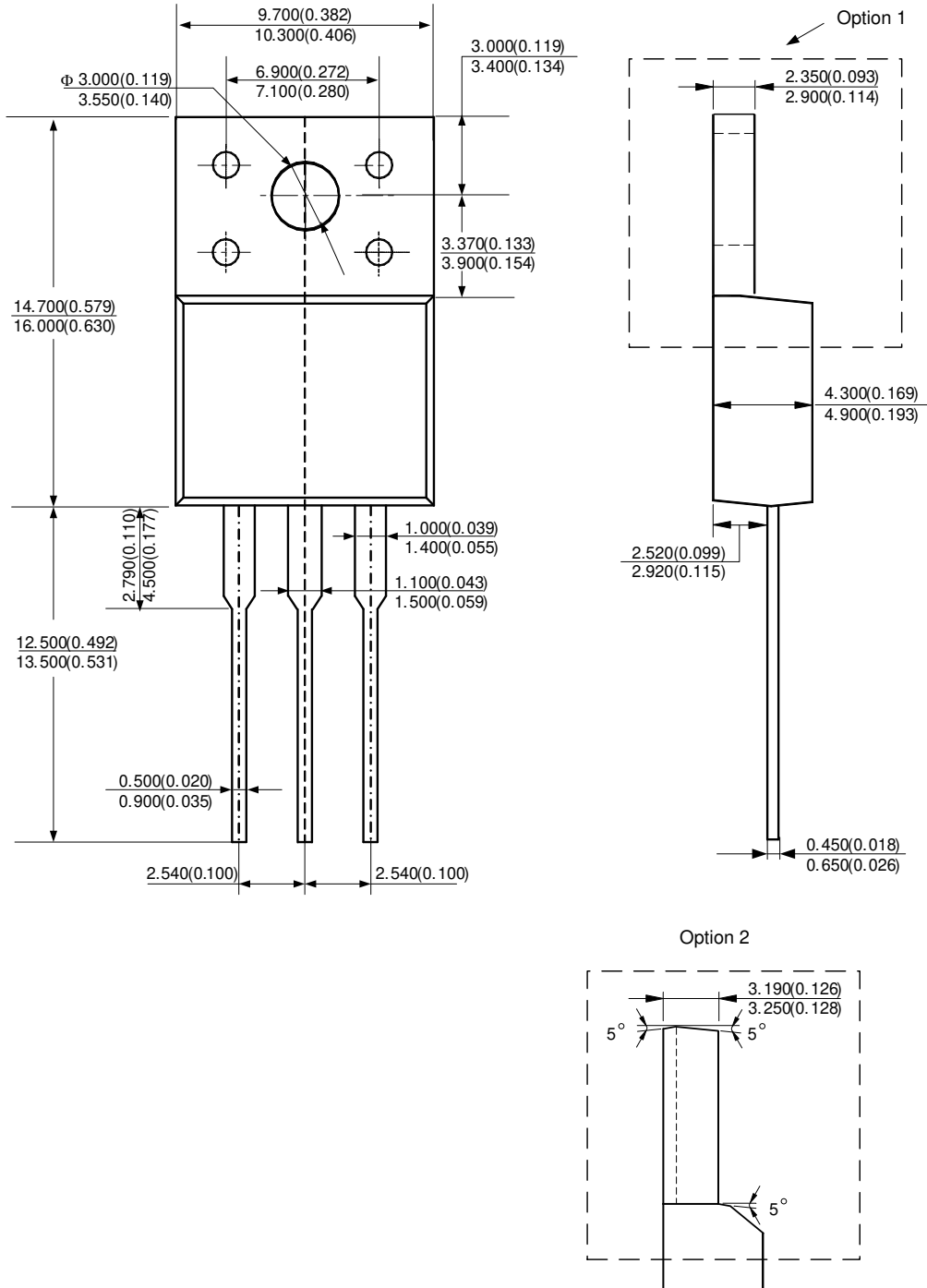

Package Outline Dimensions (Cont. All dimensions in mm(inch).)

(3) Package Type: TO-263-3

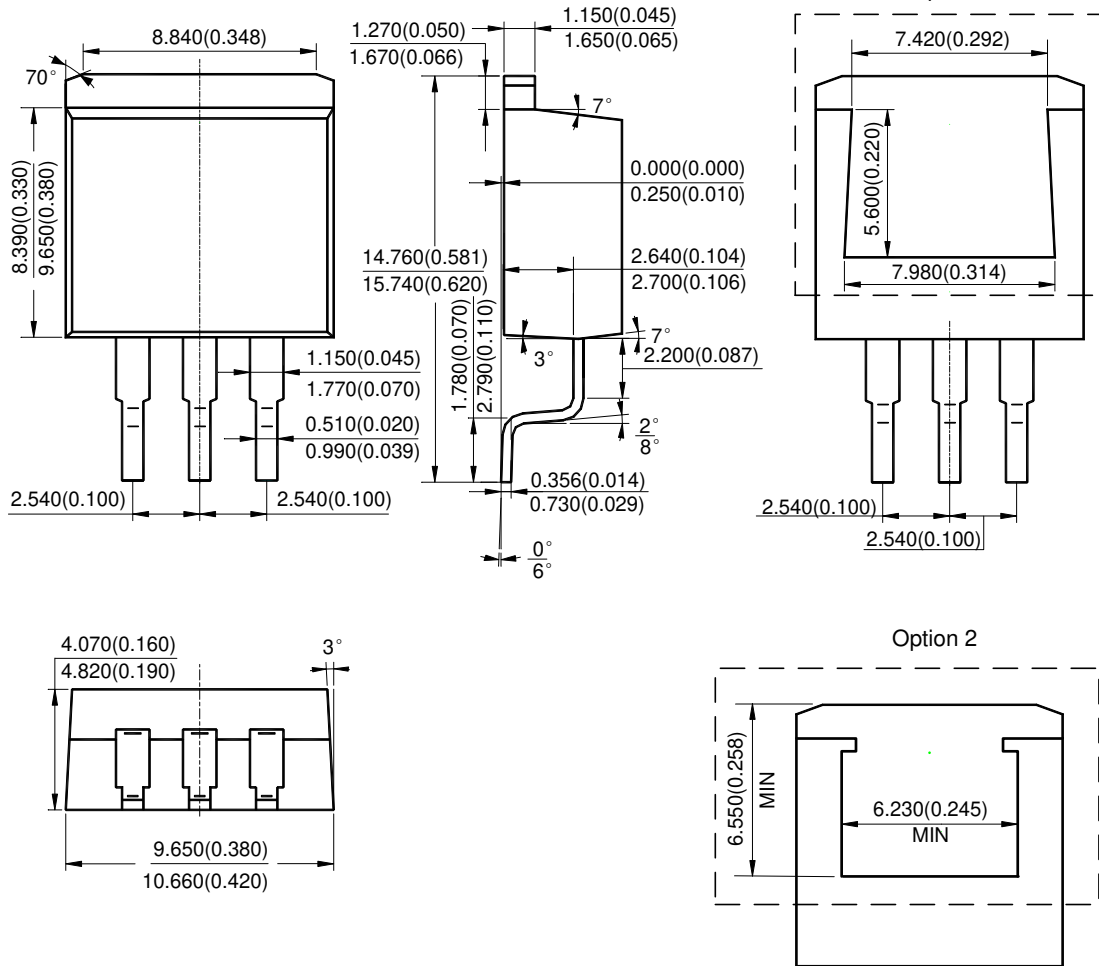

Package Outline Dimensions (Cont. All dimensions in mm(inch).)

(4) Package Type: SOT-223

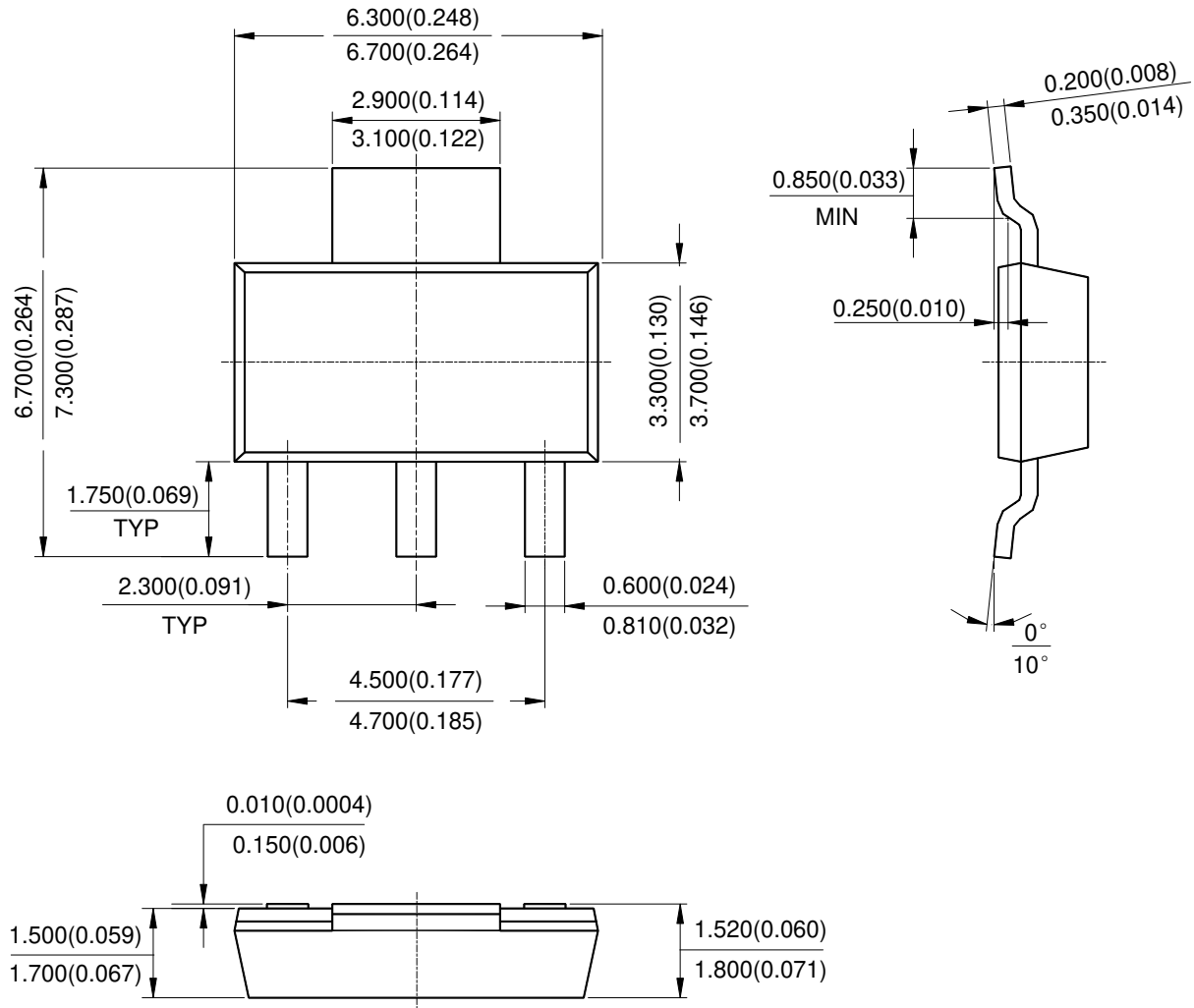

Package Outline Dimensions (Cont. All dimensions in mm(inch).)

(5) Package Type: TO-252-2 (3)

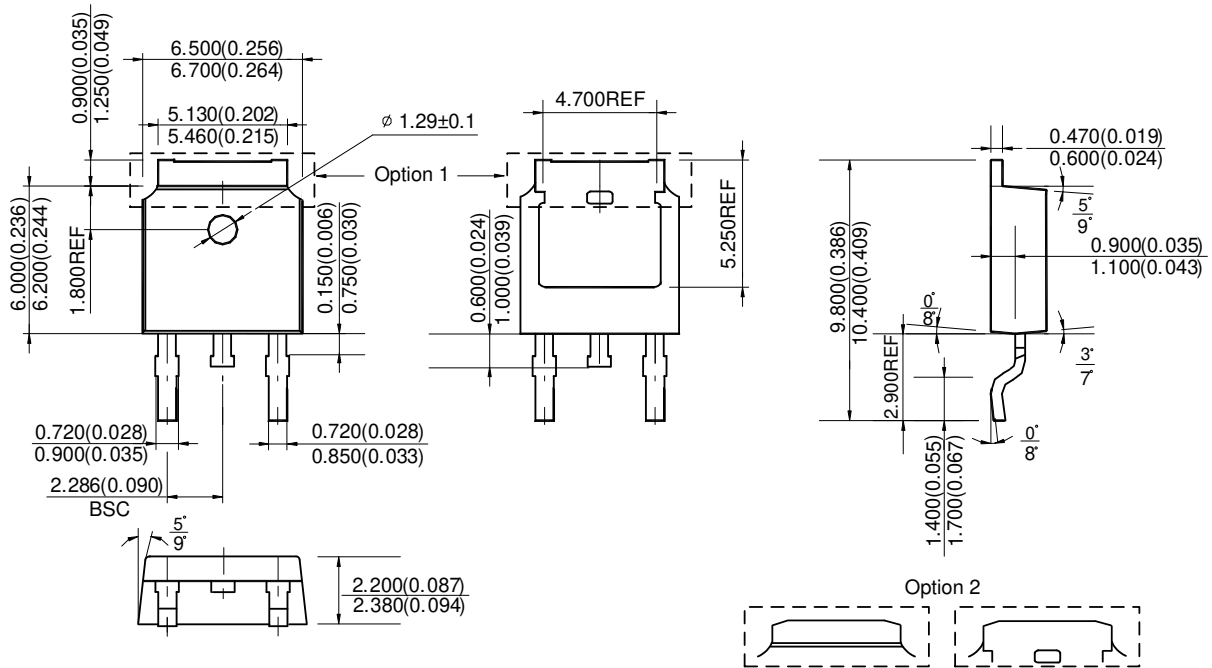

Package Outline Dimensions (Cont. All dimensions in mm(inch).)

(6) Package Type: TO-252-2 (4)

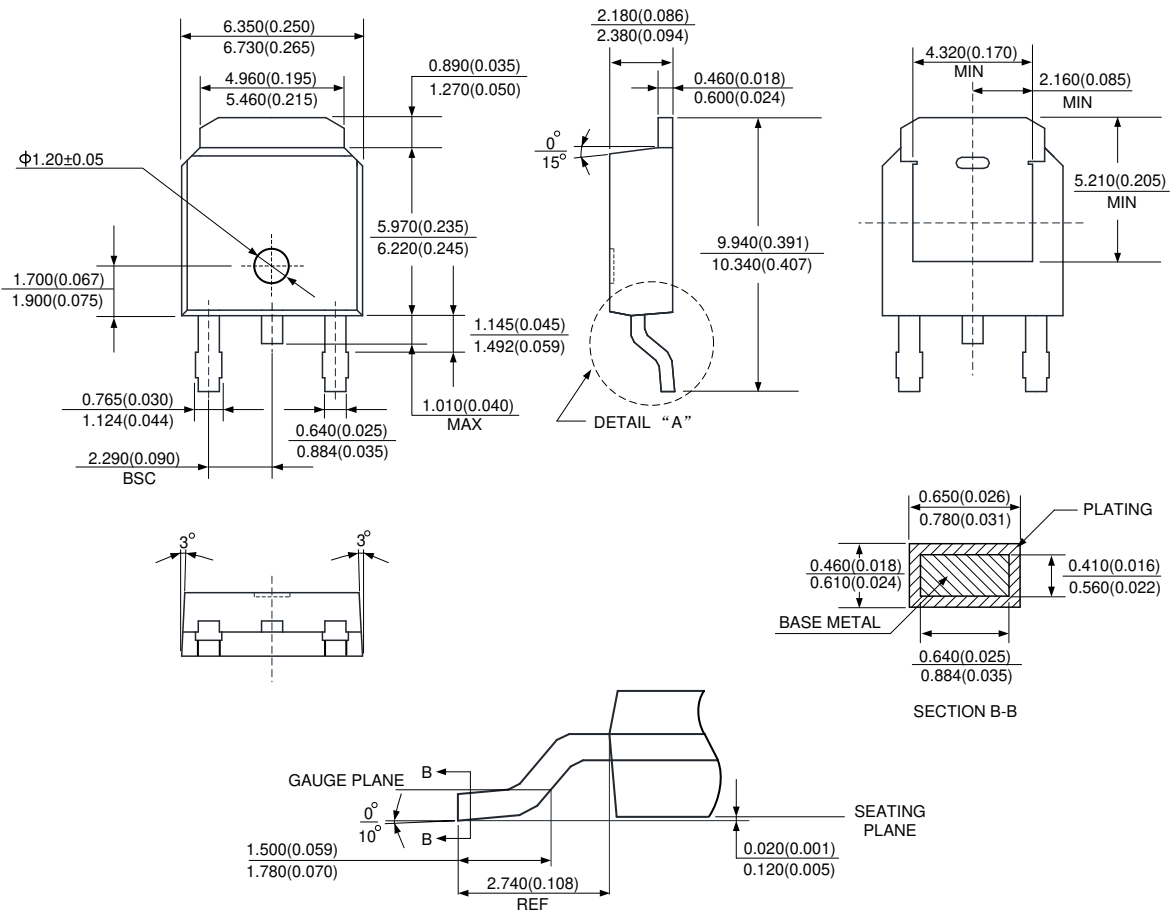

Package Outline Dimensions (Cont. All dimensions in mm(inch).)

(7) Package Type: TO-252-2 (5)

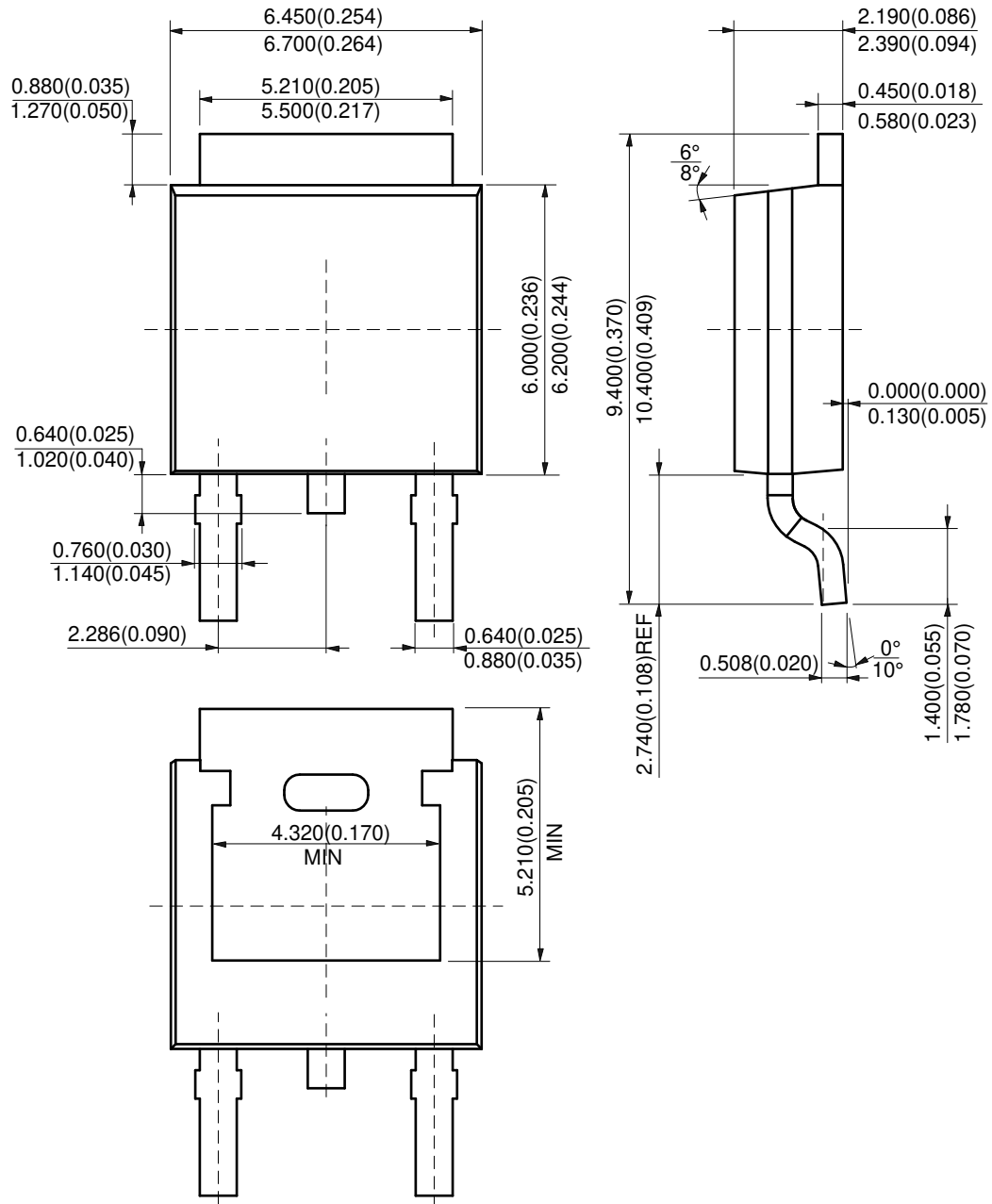

Suggested Pad Layout

(1) Package Type: TO-263-3

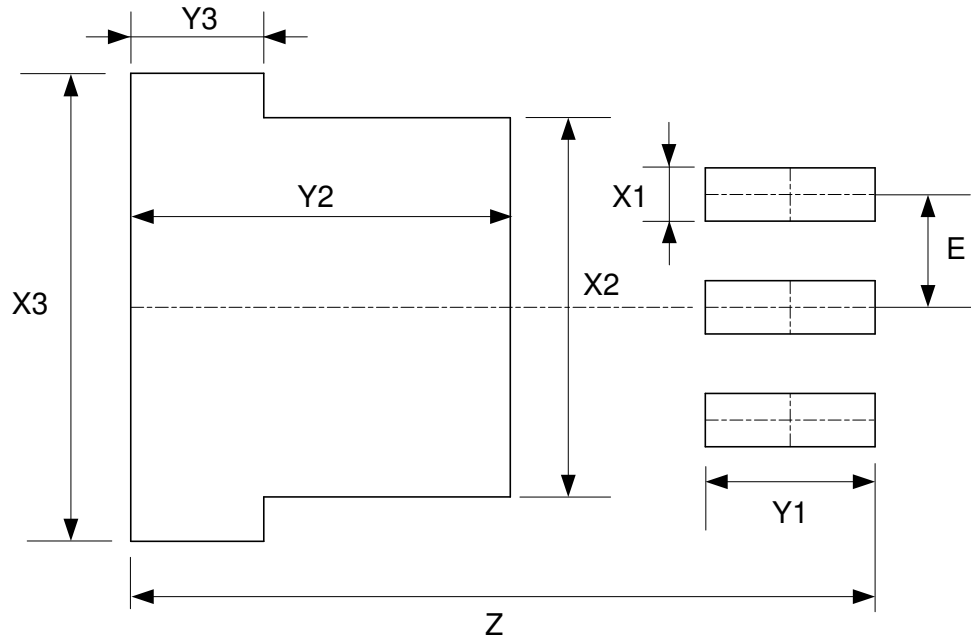

Dimensions	Z (mm)/(inch)	X1 (mm)/(inch)	X2 (mm)/(inch)	X3 (mm)/(inch)
Value	16.760/0.660	1.200/0.047	8.540/0.336	10.540/0.415
Dimensions	Y1 (mm)/(inch)	Y2 (mm)/(inch)	Y3 (mm)/(inch)	E (mm)/(inch)
Value	3.830/0.151	8.560/0.337	3.000/0.118	2.540/0.100

Suggested Pad Layout (Cont.)

(2) Package Type: SOT-223

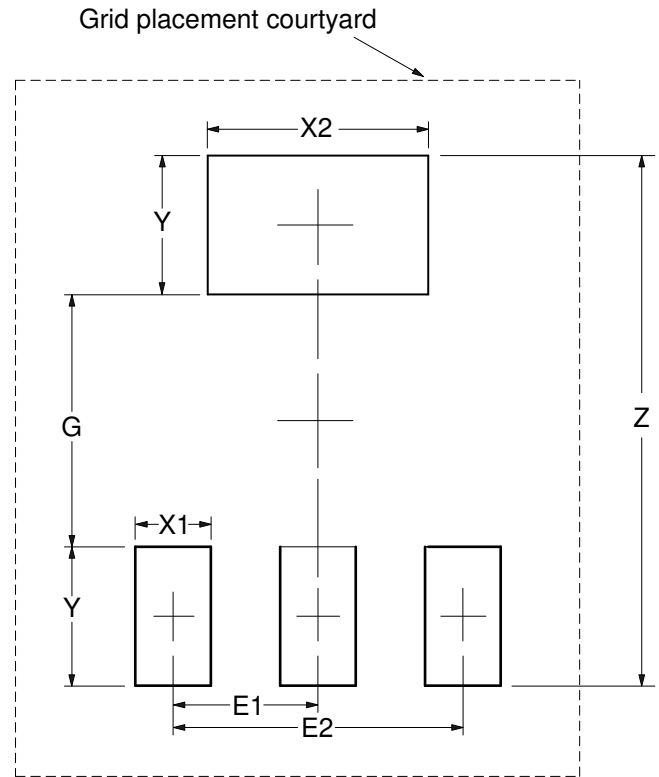

Dimensions	Z (mm)/(inch)	G (mm)/(inch)	X1 (mm)/(inch)	X2 (mm)/(inch)	Y (mm)/(inch)	E1 (mm)/(inch)	E2 (mm)/(inch)
Value	8.400/0.331	4.000/0.157	1.200/0.047	3.500/0.138	2.200/0.087	2.300/0.091	4.600/0.181