



Chipsmall Limited consists of a professional team with an average of over 10 year of expertise in the distribution of electronic components. Based in Hongkong, we have already established firm and mutual-benefit business relationships with customers from,Europe,America and south Asia,supplying obsolete and hard-to-find components to meet their specific needs.

With the principle of "Quality Parts,Customers Priority,Honest Operation,and Considerate Service",our business mainly focus on the distribution of electronic components. Line cards we deal with include Microchip,ALPS,ROHM,Xilinx,Pulse,ON,Everlight and Freescale. Main products comprise IC,Modules,Potentiometer,IC Socket,Relay,Connector.Our parts cover such applications as commercial,industrial, and automotives areas.

We are looking forward to setting up business relationship with you and hope to provide you with the best service and solution. Let us make a better world for our industry!



Contact us

Tel: +86-755-8981 8866 Fax: +86-755-8427 6832

Email & Skype: info@chipsmall.com Web: www.chipsmall.com

Address: A1208, Overseas Decoration Building, #122 Zhenhua RD., Futian, Shenzhen, China



LOW VOLTAGE (1.25V) ADJUSTABLE PRECISION SHUNT REGULATOR

Description

The AZ432 series ICs are low voltage three-terminal adjustable regulators with guaranteed thermal stability over a full operation range. These ICs feature sharp turn-on characteristics, low temperature coefficient and low output impedance, which make them ideal substitutes for Zener diodes in applications such as switching power supply, charger, motherboard and other adjustable regulators.

The output voltage can be set to any value between 1.25V and 18V with two external resistors.

The AZ432 precision reference is offered in two voltage tolerance: 0.5% and 1.0%.

These ICs are available in 4 packages: TO-92 (bulk or ammo packing), SOT-23, SOT-23-5 and SOT-89.

Features

- Wide Programmable Precise Output Voltage from 1.25V to 18V
- High Stability under Capacitive Load
- Low Temperature Deviation: 3mV Typical
- Low Equivalent Full-Range Temperature Coefficient: 20PPM/°C Typical
- Low Dynamic Output Resistance: 0.05Ω Typical
- High Sink Current Capacity from 0.1mA to 100mA
- Low Output Noise
- Wide Operating Range of -40 to +125°C

Applications

- Graphic Card
- PC Motherboard
- Voltage Adapter
- Switching Power Supply
- Charger

Pin Assignments

(Top View)

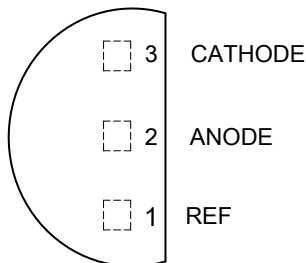

(TO-92 (Bulk Packing)/ Z Package)

(Top View)

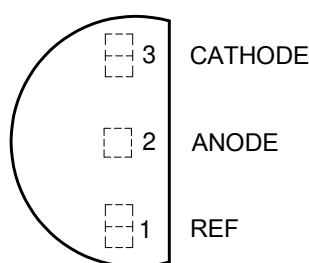

(TO-92 (Ammo Packing)/ Z Package)

(Top View)

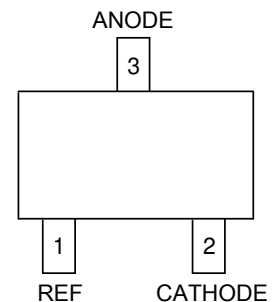

(SOT-23/ N Package)

Pin Assignments (Cont.)

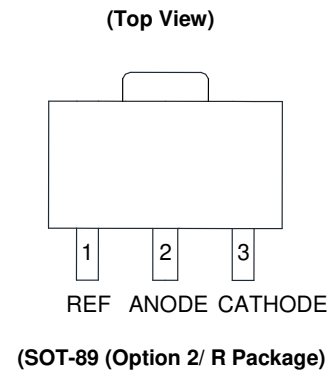
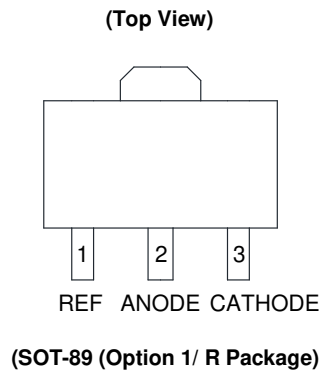
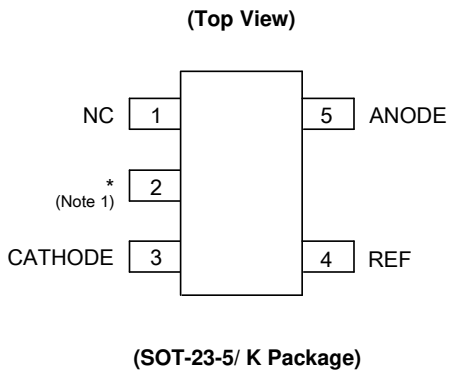

Note 1: *Pin 2 is attached to substrate and must be connected to ANODE or open.

Typical Applications Circuit

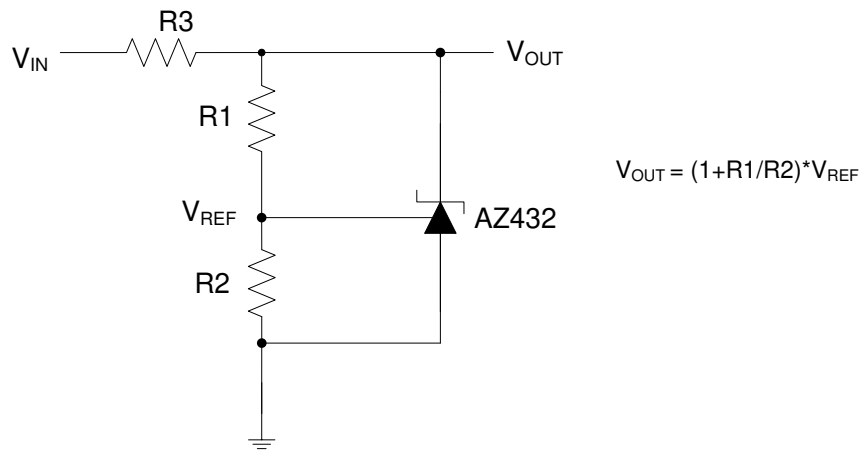

Shunt Regulator

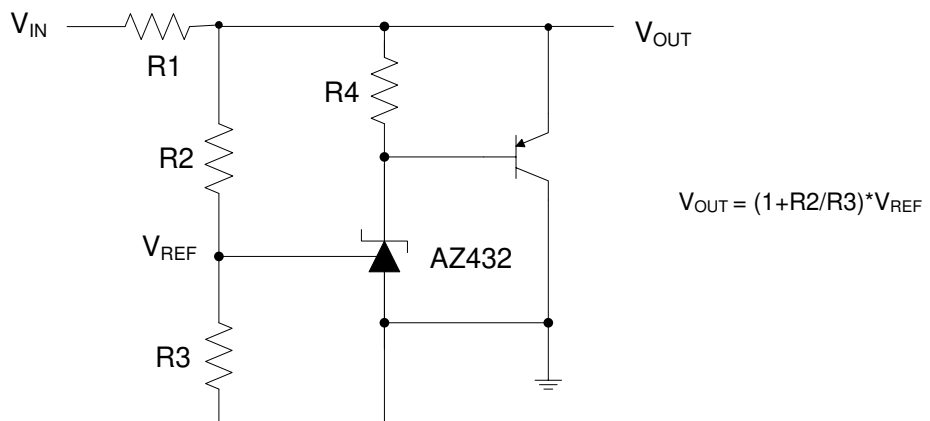

High Current Shunt Regulator

Typical Applications Circuit (Cont.)

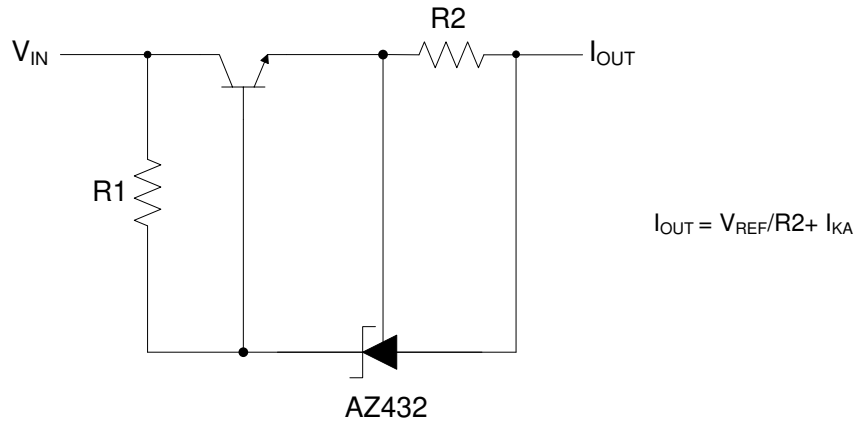

Current Source or Current Limit

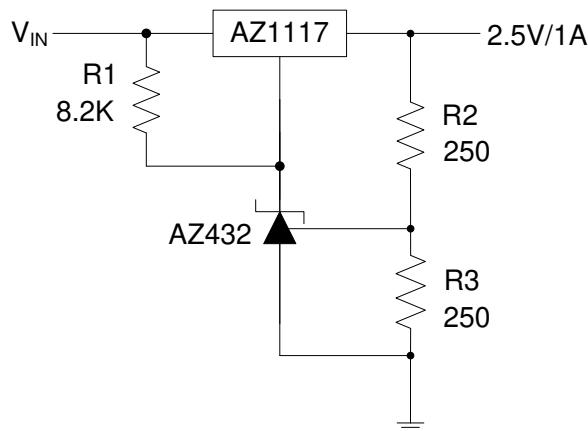

Precision 2.5V/1A Regulator

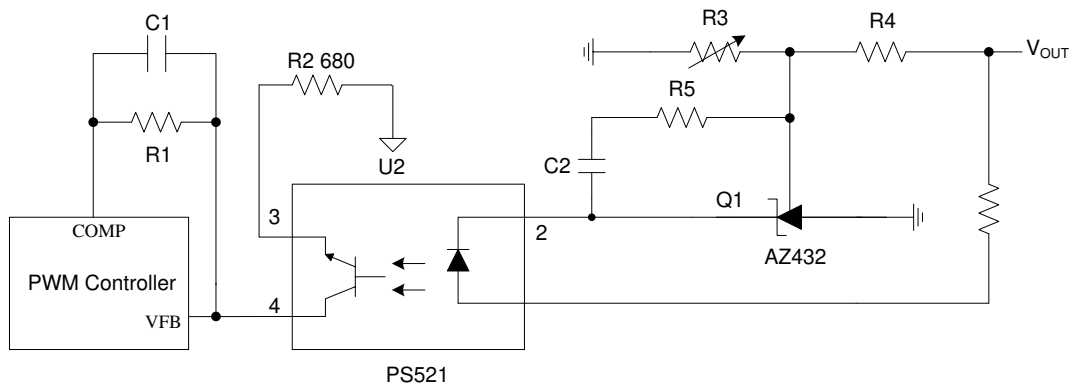

PWM Converter with Reference

Functional Block Diagram

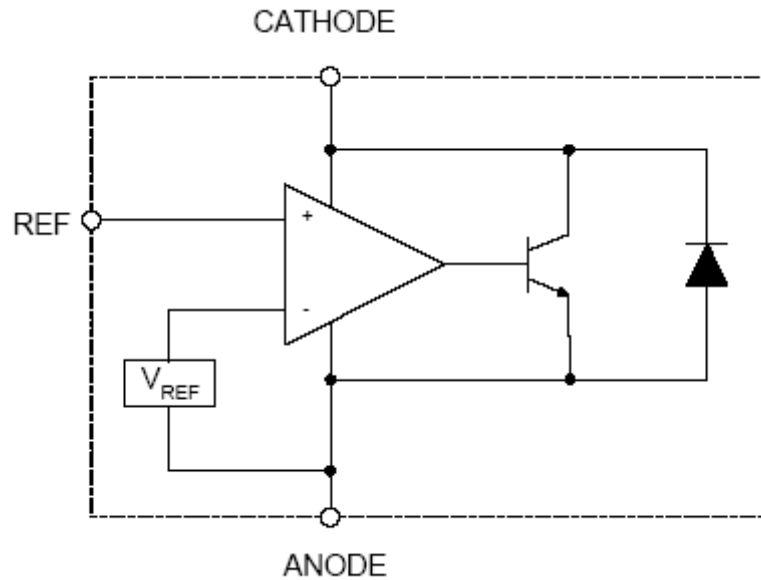

Absolute Maximum Ratings (Note 2)

Symbol	Parameter	Rating		Unit
V_{KA}	Cathode Voltage	20		V
I_{KA}	Cathode Current Range (Continuous)	-100 to 100		mA
I_{REF}	Reference Input Current Range	10		mA
P_D	Power Dissipation	Z, R Package	770	mW
		N, K Package	370	
T_J	Junction Temperature	+150		°C
T_{STG}	Storage Temperature Range	-65 to +150		°C

Note 2: Stresses greater than those listed under “Absolute Maximum Ratings” may cause permanent damage to the device. These are stress ratings only, and functional operation of the device at these or any other conditions beyond those indicated under “Recommended Operating Conditions” is not implied. Exposure to “Absolute Maximum Ratings” for extended periods may affect device reliability.

Recommended Operating Conditions

Symbol	Parameter	Min	Max	Unit
V_{KA}	Cathode Voltage	V_{REF}	18	V
I_{KA}	Cathode Current	0.1	100	mA
—	Operating Ambient Temperature Range	-40	+125	°C

Electrical Characteristics (Typical and limits apply for $T_A = +25\text{ }^\circ\text{C}$, unless otherwise noted.)

Symbol	Parameter		Test Circuit	Conditions	Min	Typ	Max	Unit	
V_{REF}	Reference Voltage	0.5%	4	$V_{KA} = V_{REF}, I_{KA} = 10\text{mA}$	1.244	1.250	1.256	V	
		1.0%			1.238	1.250	1.262		
ΔV_{REF}	Deviation of Reference Voltage Over Full Temperature Range		4	$V_{KA} = V_{REF}, I_{KA} = 10\text{mA}$	0 to $+70\text{ }^\circ\text{C}$	-	2	10	mV
					-40 to $+85\text{ }^\circ\text{C}$	-	3	10	
					-40 to $+125\text{ }^\circ\text{C}$	-	4	15	
$\frac{\Delta V_{REF}}{\Delta V_{KA}}$	Ratio of Change in V_{REF} to the Change in Cathode Voltage		5	$I_{KA} = 10\text{mA}, \Delta V_{KA}: V_{REF} \text{ to } 16\text{V}$	-	-0.5	-1.5	mV/V	
I_{REF}	Reference Input Current		5	$I_{KA} = 10\text{mA}, R1 = 10\text{K}\Omega, R2 = \infty$	-	0.15	0.4	μA	
ΔI_{REF}	Deviation of Reference Current Over Full Temperature Range		5	$I_{KA} = 10\text{mA}, R1 = 10\text{K}\Omega, R2 = \infty, T_A = -40 \text{ to } +125\text{ }^\circ\text{C}$	-	0.1	0.4	μA	
I_{KA} (Min)	Minimum Cathode Current for Regulation		4	$V_{KA} = V_{REF}$	-	55	80	μA	
I_{KA} (Off)	Off-state Cathode Current		6	$V_{REF} = 0, V_{KA} = 18\text{V}$	-	0.04	0.10	μA	
					$V_{KA} = 6\text{V}, V_{REF} = 0$	-	0.01		0.05
Z_{KA}	Dynamic Impedance		4	$V_{KA} = V_{REF}, I_{KA} = 1 \text{ to } 100\text{mA}, f \leq 1.0\text{KHz}$	-	0.05	0.15	Ω	
θ_{JC}	Thermal Resistance (Junction to Case)		-	SOT-23	-	84.84	-	$^\circ\text{C/W}$	
				SOT-23-5	-	84.84	-		
				TO-92	-	140.80	-		
				SOT-89	-	29.80	-		

Electrical Characteristics (Cont.)

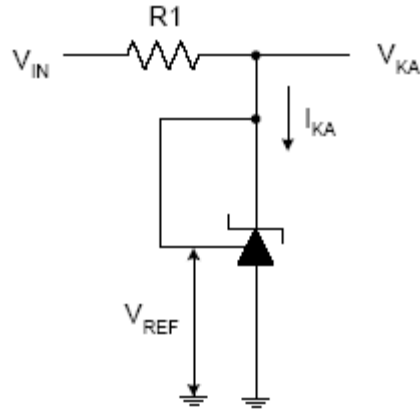

Test Circuit 4 for $V_{KA} = V_{REF}$

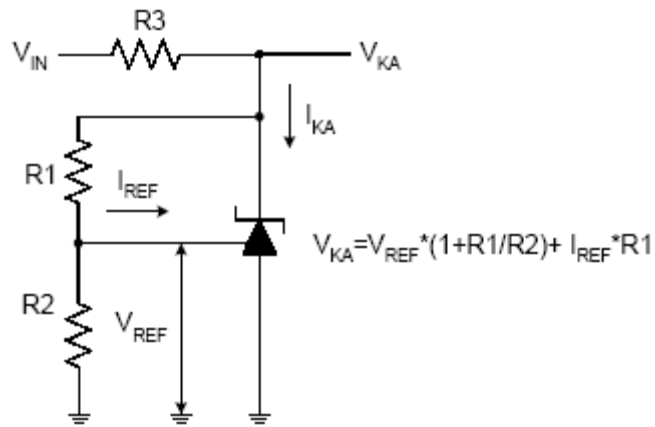

Test Circuit 5 for $V_{KA} > V_{REF}$

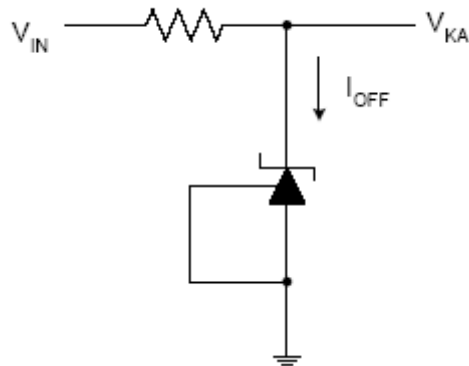

Test Circuit 6 for I_{OFF}

Performance Characteristics

Reference Voltage vs. Ambient Temperature

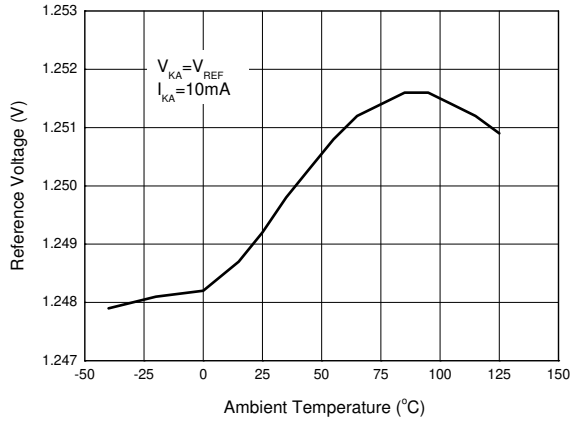

Reference Current vs. Ambient Temperature

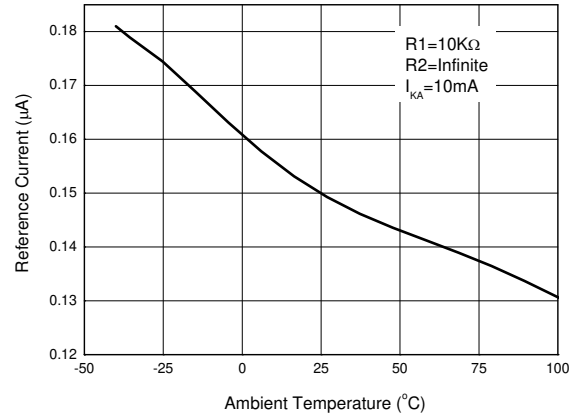

Cathode Current vs. Cathode Voltage

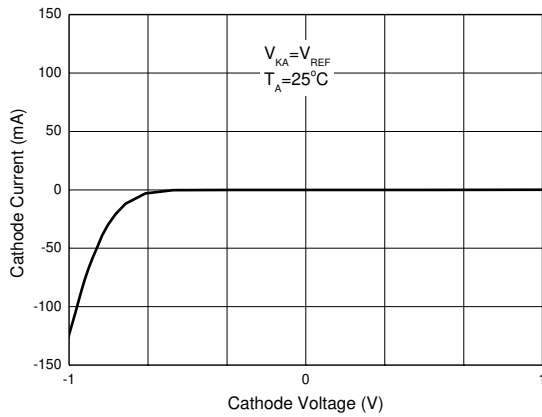

Cathode Current vs. Cathode Voltage

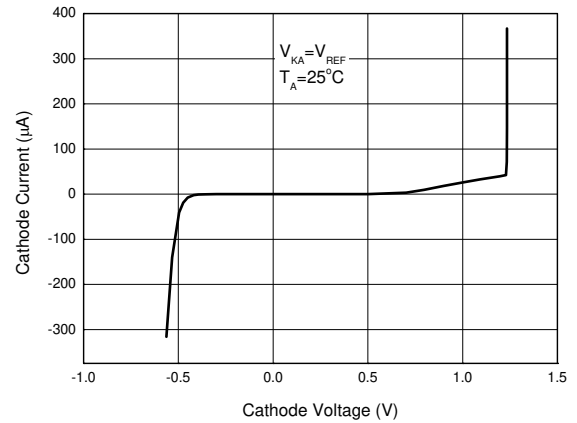

Small Signal Voltage Gain vs. Frequency

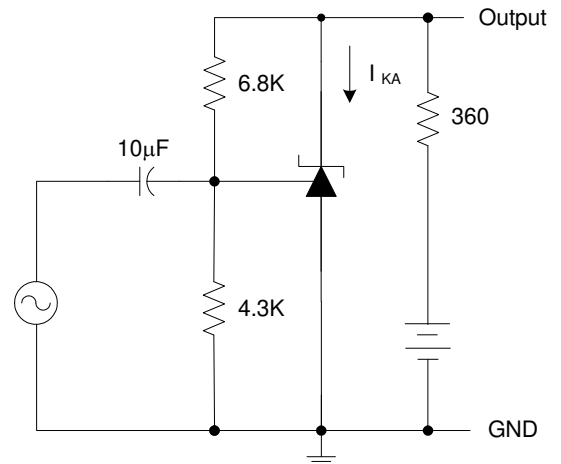
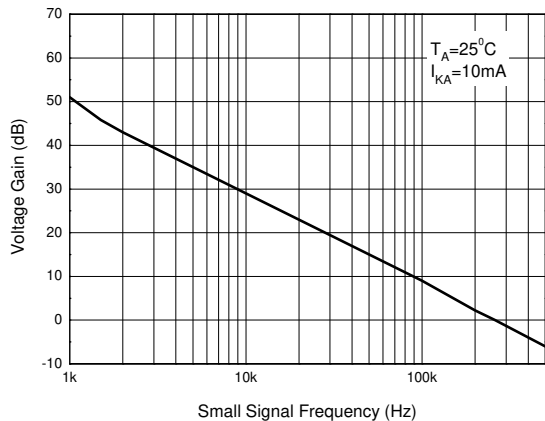

Performance Characteristics (Cont.)

Dynamic Impedance vs. Frequency

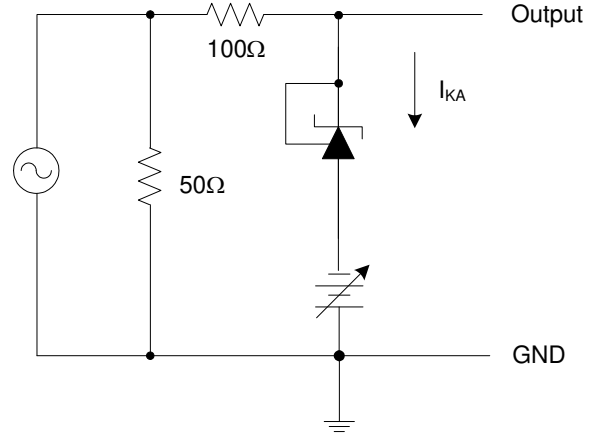
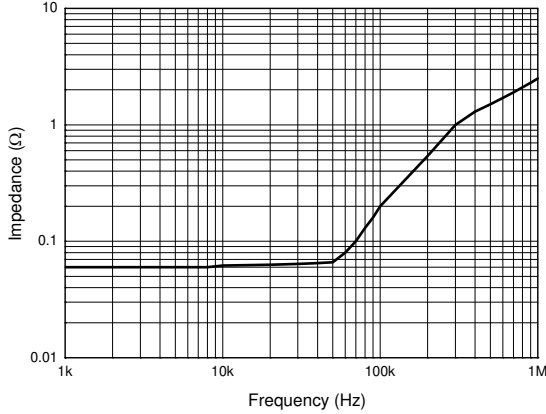

Pulse Response of Input and Output Voltage

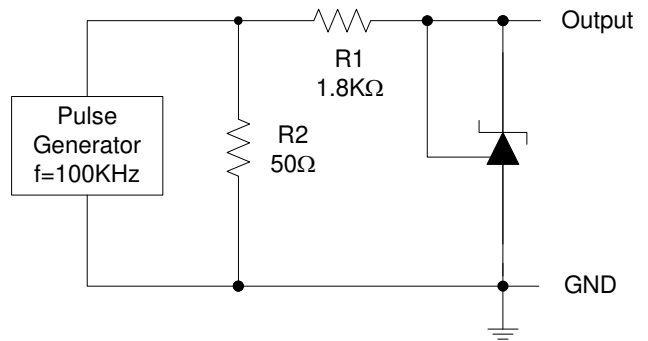
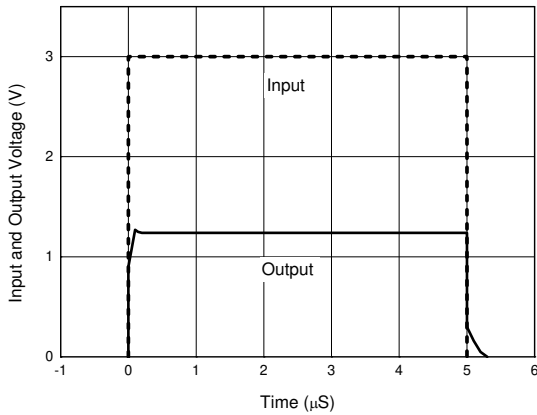

Ratio of Delta Reference Voltage to the Ratio of Delta Cathode Voltage vs. Ambient Temperature

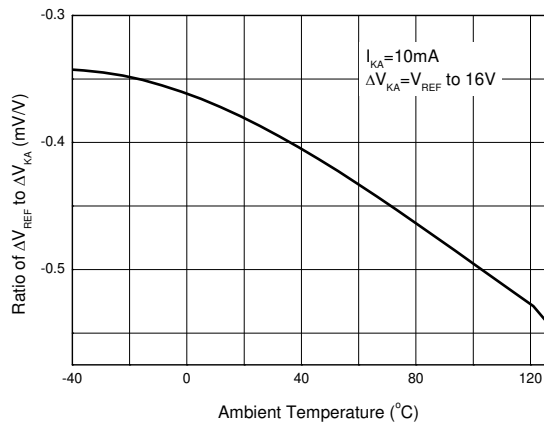

Ordering Information

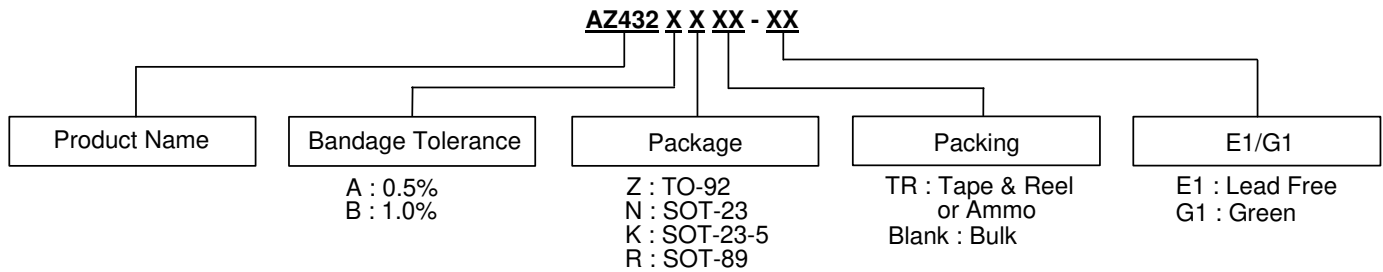

Diodes IC's Pb-free products, as designated with "E1" suffix in the part number, are RoHS compliant.
Products with "G1" suffix are available in green packages.

Package	Temperature Range	Voltage Tolerance	Part Number		Marking ID		Packing Type
			Lead Free	Green	Lead Free	Green	
TO-92	-40 to +125°C	0.5%	AZ432AZ-E1	AZ432AZ-G1	AZ432AZ-E1	AZ432AZ-G1	Bulk
		0.5%	AZ432AZTR-E1	AZ432AZTR-G1	AZ432AZ-E1	AZ432AZ-G1	Ammo
		1.0%	AZ432BZ-E1	AZ432BZ-G1	AZ432BZ-E1	AZ432BZ-G1	Bulk
		1.0%	AZ432BZTR-E1	AZ432BZTR-G1	AZ432BZ-E1	AZ432BZ-G1	Ammo
SOT-23	-40 to +125°C	0.5%	AZ432ANTR-E1	AZ432ANTR-G1	EA8	GA8	Tape & Reel
		1.0%	AZ432BNTR-E1	AZ432BNTR-G1	EA9	GA9	Tape & Reel
SOT-23-5	-40 to +125°C	0.5%	AZ432AKTR-E1	AZ432AKTR-G1	E7A	G7A	Tape & Reel
		1.0%	AZ432BKTR-E1	AZ432BKTR-G1	E8A	G8A	Tape & Reel
SOT-89	-40 to +125°C	0.5%	AZ432ARTR-E1	AZ432ARTR-G1	E42A	G42A	Tape & Reel
		1.0%	AZ432BRTR-E1	AZ432BRTR-G1	E42B	G42B	Tape & Reel

Package Outline Dimensions (All dimensions in mm(inch).)

(1) Package Type: TO-92 (Bulk Packing)

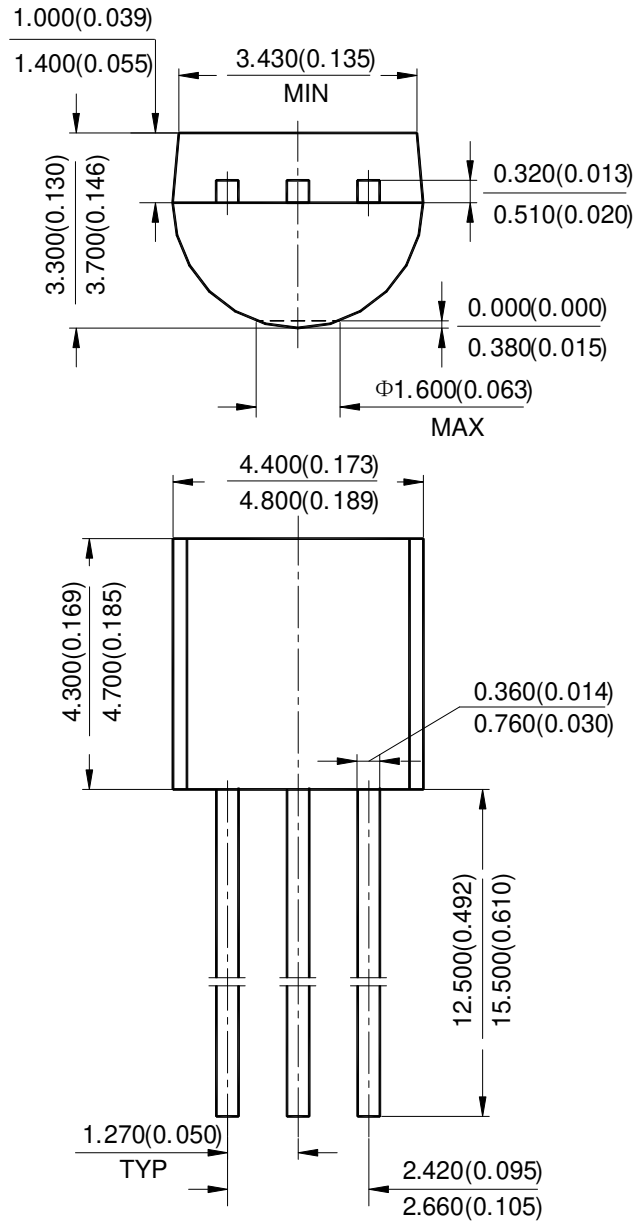

Package Outline Dimensions (Cont. All dimensions in mm(inch).)

(2) Package Type: TO-92 (Ammo Packing)

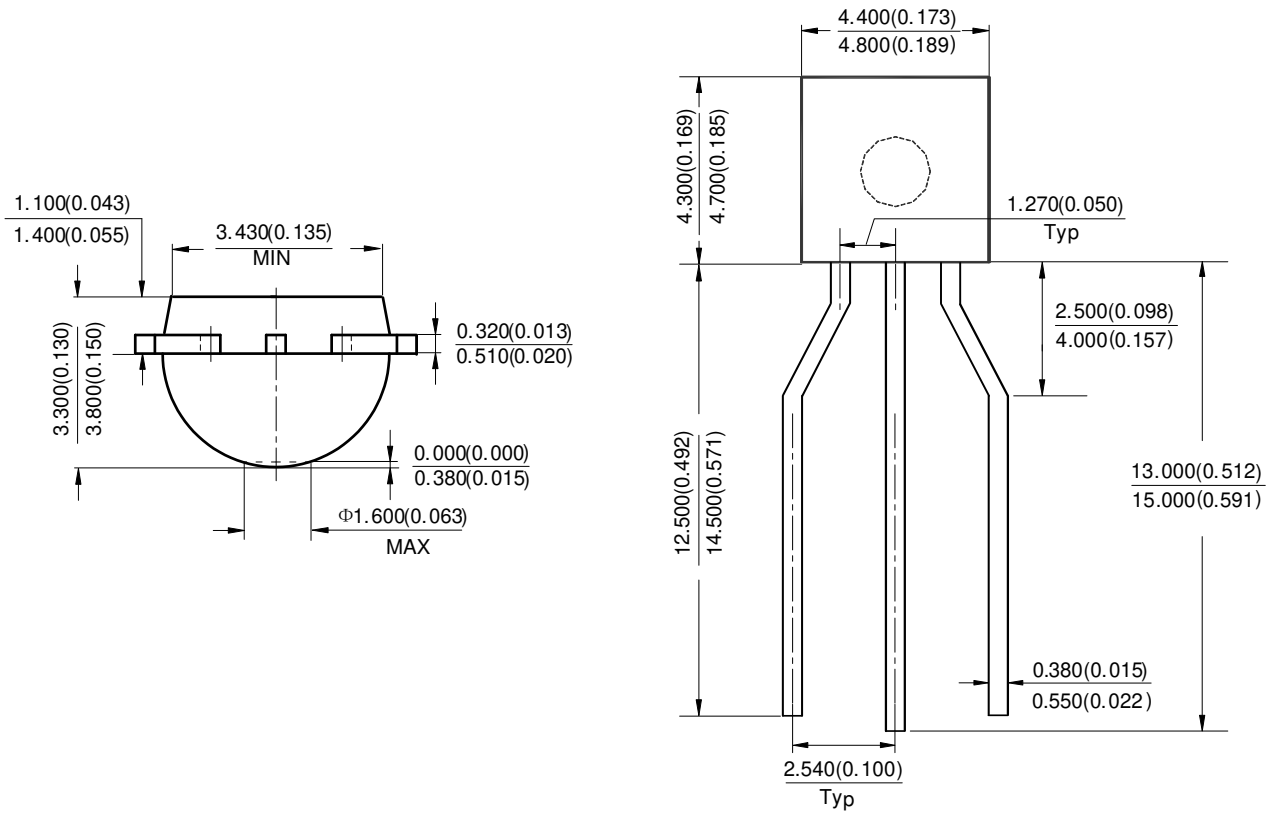

Package Outline Dimensions (Cont. All dimensions in mm(inch).)

(3) Package Type: SOT-23

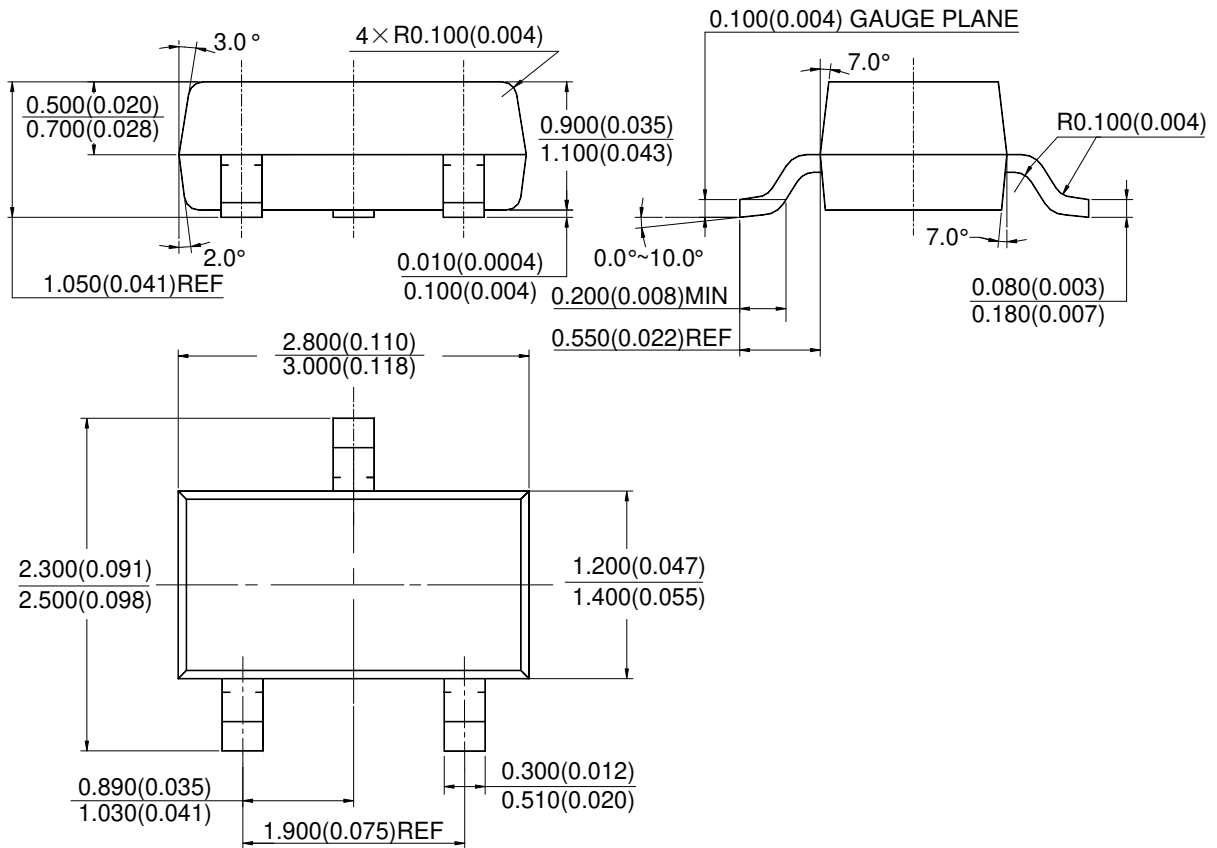

Package Outline Dimensions (Cont. All dimensions in mm(inch).)

(4) Package Type: SOT-23-5

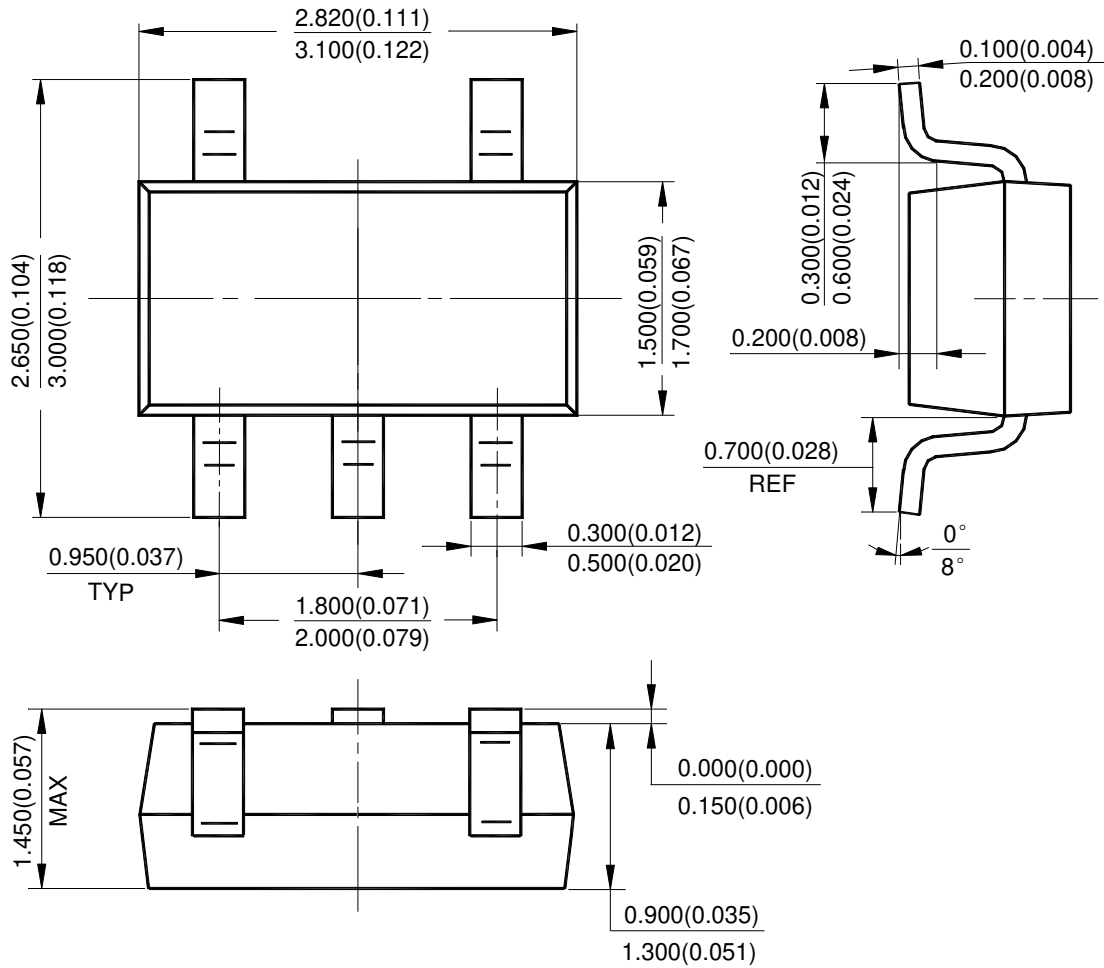

Package Outline Dimensions (Cont. All dimensions in mm(inch).)

(5) Package Type: SOT-89

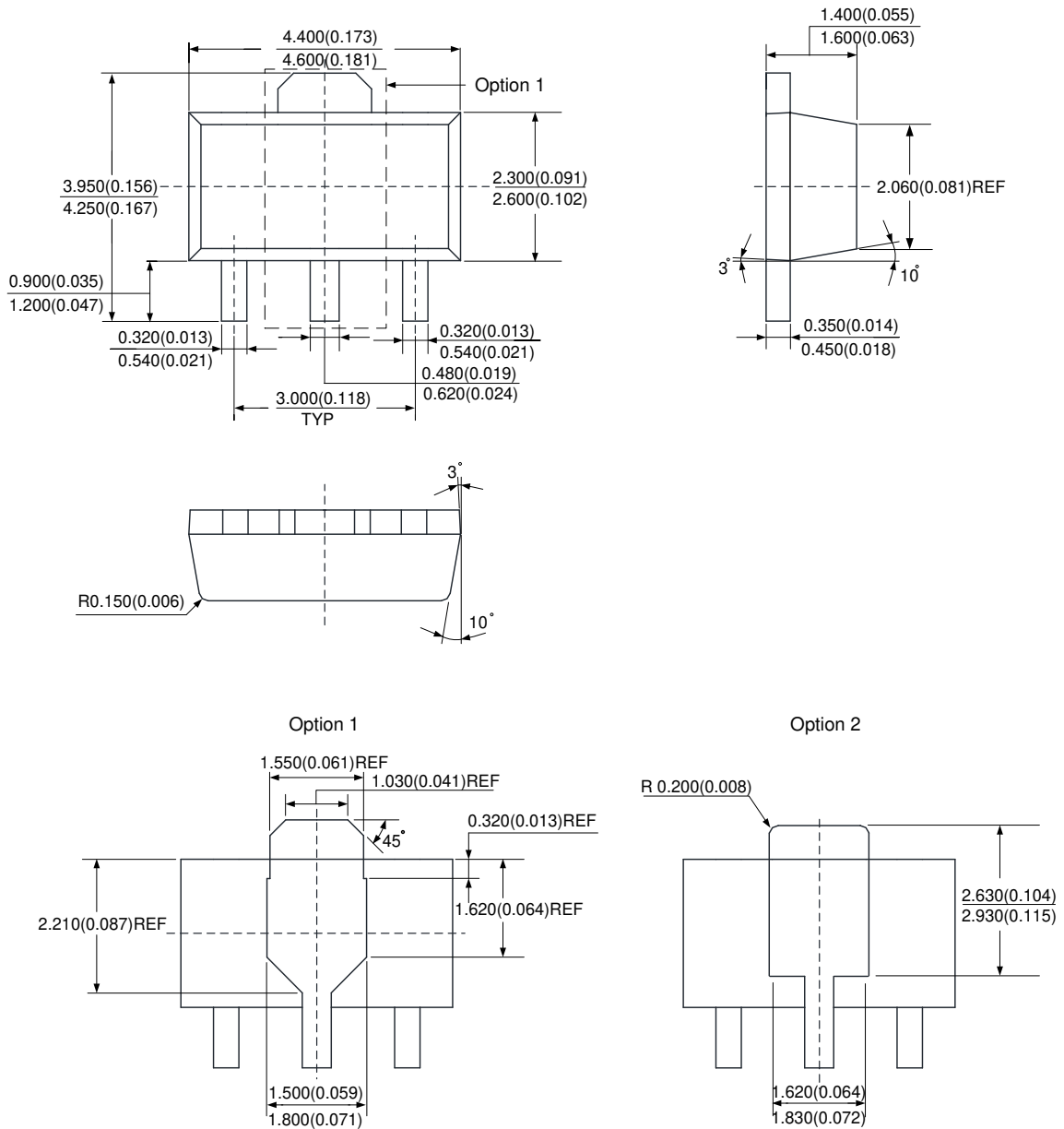

Suggested Pad Layout

(1) Package Type: SOT-23

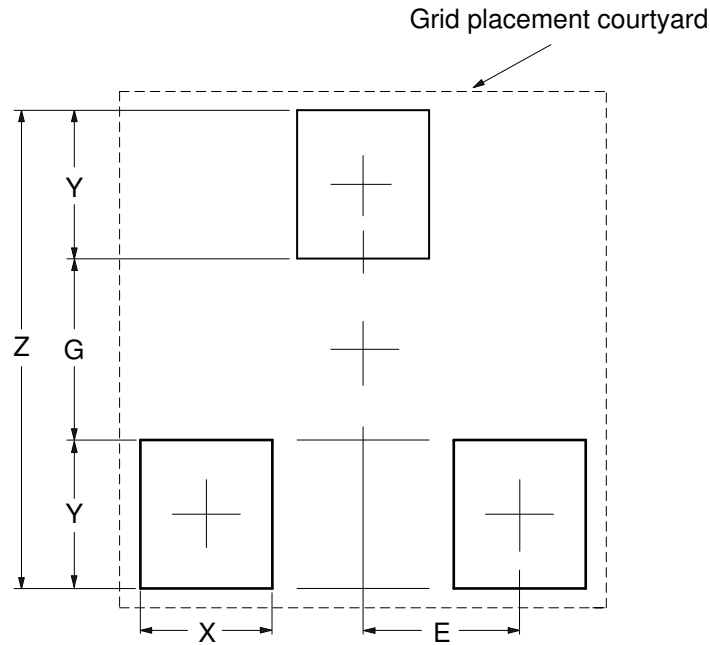

Dimensions	Z (mm)/(inch)	G (mm)/(inch)	X (mm)/(inch)	Y (mm)/(inch)	E (mm)/(inch)
Value	2.900/0.114	1.100/0.043	0.800/0.031	0.900/0.035	0.950/0.037

Suggested Pad Layout (Cont.)

(2) Package Type: SOT-23-5

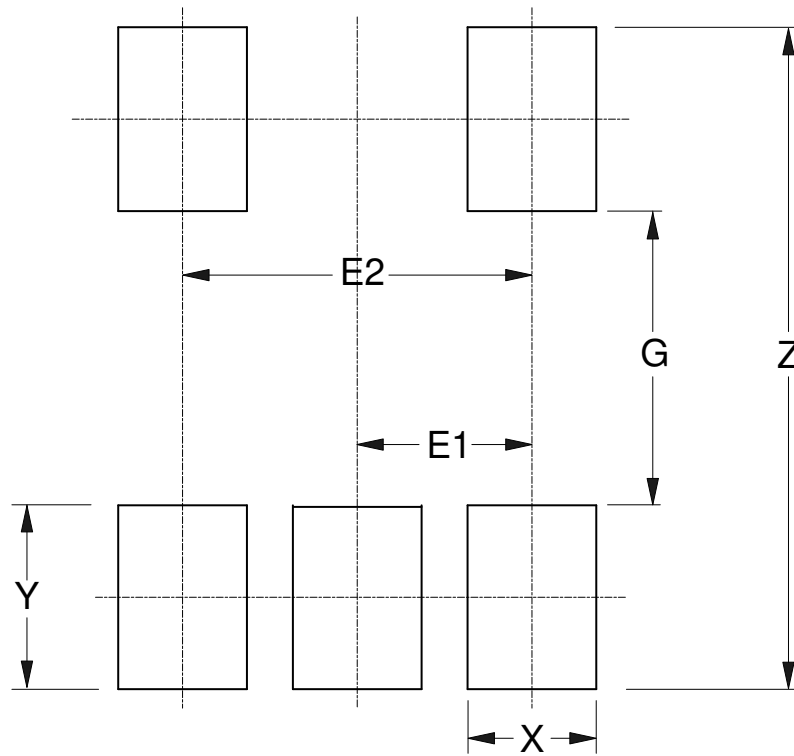

Dimensions	Z (mm)/(inch)	G (mm)/(inch)	X (mm)/(inch)	Y (mm)/(inch)	E1 (mm)/(inch)	E2 (mm)/(inch)
Value	3.600/0.142	1.600/0.063	0.700/0.028	1.000/0.039	0.950/0.037	1.900/0.075

Suggested Pad Layout (Cont.)

(3) Package Type: SOT-89

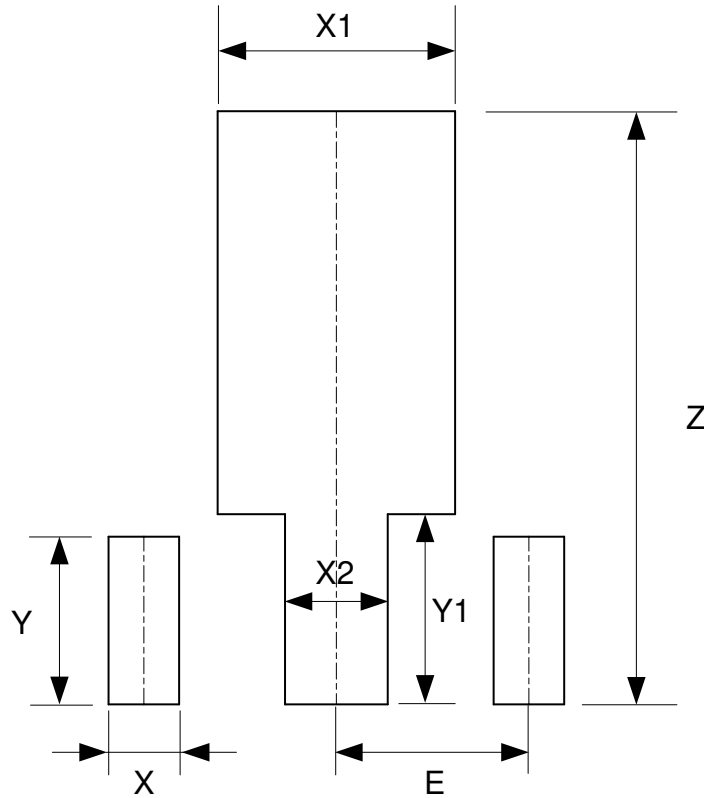

Dimensions	Z (mm)/(inch)	X (mm)/(inch)	X1 (mm)/(inch)	X2 (mm)/(inch)	Y (mm)/(inch)	Y1 (mm)/(inch)	E (mm)/(inch)
Value	4.600/0.181	0.550/0.022	1.850/0.073	0.800/0.031	1.300/0.051	1.475/0.058	1.500/0.059

IMPORTANT NOTICE

DIODES INCORPORATED MAKES NO WARRANTY OF ANY KIND, EXPRESS OR IMPLIED, WITH REGARDS TO THIS DOCUMENT, INCLUDING, BUT NOT LIMITED TO, THE IMPLIED WARRANTIES OF MERCHANTABILITY AND FITNESS FOR A PARTICULAR PURPOSE (AND THEIR EQUIVALENTS UNDER THE LAWS OF ANY JURISDICTION).

Diodes Incorporated and its subsidiaries reserve the right to make modifications, enhancements, improvements, corrections or other changes without further notice to this document and any product described herein. Diodes Incorporated does not assume any liability arising out of the application or use of this document or any product described herein; neither does Diodes Incorporated convey any license under its patent or trademark rights, nor the rights of others. Any Customer or user of this document or products described herein in such applications shall assume all risks of such use and will agree to hold Diodes Incorporated and all the companies whose products are represented on Diodes Incorporated website, harmless against all damages.

Diodes Incorporated does not warrant or accept any liability whatsoever in respect of any products purchased through unauthorized sales channel. Should Customers purchase or use Diodes Incorporated products for any unintended or unauthorized application, Customers shall indemnify and hold Diodes Incorporated and its representatives harmless against all claims, damages, expenses, and attorney fees arising out of, directly or indirectly, any claim of personal injury or death associated with such unintended or unauthorized application.

Products described herein may be covered by one or more United States, international or foreign patents pending. Product names and markings noted herein may also be covered by one or more United States, international or foreign trademarks.

This document is written in English but may be translated into multiple languages for reference. Only the English version of this document is the final and determinative format released by Diodes Incorporated.

LIFE SUPPORT

Diodes Incorporated products are specifically not authorized for use as critical components in life support devices or systems without the express written approval of the Chief Executive Officer of Diodes Incorporated. As used herein:

A. Life support devices or systems are devices or systems which:

1. are intended to implant into the body, or
2. support or sustain life and whose failure to perform when properly used in accordance with instructions for use provided in the labeling can be reasonably expected to result in significant injury to the user.

B. A critical component is any component in a life support device or system whose failure to perform can be reasonably expected to cause the failure of the life support device or to affect its safety or effectiveness.

Customers represent that they have all necessary expertise in the safety and regulatory ramifications of their life support devices or systems, and acknowledge and agree that they are solely responsible for all legal, regulatory and safety-related requirements concerning their products and any use of Diodes Incorporated products in such safety-critical, life support devices or systems, notwithstanding any devices- or systems-related information or support that may be provided by Diodes Incorporated. Further, Customers must fully indemnify Diodes Incorporated and its representatives against any damages arising out of the use of Diodes Incorporated products in such safety-critical, life support devices or systems.

Copyright © 2012, Diodes Incorporated

www.diodes.com