



Chipsmall Limited consists of a professional team with an average of over 10 year of expertise in the distribution of electronic components. Based in Hongkong, we have already established firm and mutual-benefit business relationships with customers from,Europe,America and south Asia,supplying obsolete and hard-to-find components to meet their specific needs.

With the principle of “Quality Parts,Customers Priority,Honest Operation,and Considerate Service”,our business mainly focus on the distribution of electronic components. Line cards we deal with include Microchip,ALPS,ROHM,Xilinx,Pulse,ON,Everlight and Freescale. Main products comprise IC,Modules,Potentiometer,IC Socket,Relay,Connector.Our parts cover such applications as commercial,industrial, and automotives areas.

We are looking forward to setting up business relationship with you and hope to provide you with the best service and solution. Let us make a better world for our industry!



Contact us

Tel: +86-755-8981 8866 Fax: +86-755-8427 6832

Email & Skype: info@chipsmall.com Web: www.chipsmall.com

Address: A1208, Overseas Decoration Building, #122 Zhenhua RD., Futian, Shenzhen, China



VOLTAGE MODE DUAL OUTPUT PWM CONTROLLER

Description

The AZ494 is a voltage mode pulse width modulation switching regulator control circuit designed primarily for power supply control.

The AZ494 consists of a reference voltage circuit, two error amplifiers, an on-chip adjustable oscillator, a dead-time control (DTC) comparator, a pulse-steering control flip-flop, and an output control circuit. The precision of voltage reference (V_{REF}) is improved up to $\pm 1\%$ through trimming and this provides a better output voltage regulation. The AZ494 provides for push-pull or single-ended output operation, which can be selected through the output control.

The difference between AZ494A and AZ494C is that they have 4.95V and 5V reference voltage respectively.

The AZ494 is available in standard packages of PDIP-16 and SO-16.

Pin Assignments

(Top View)

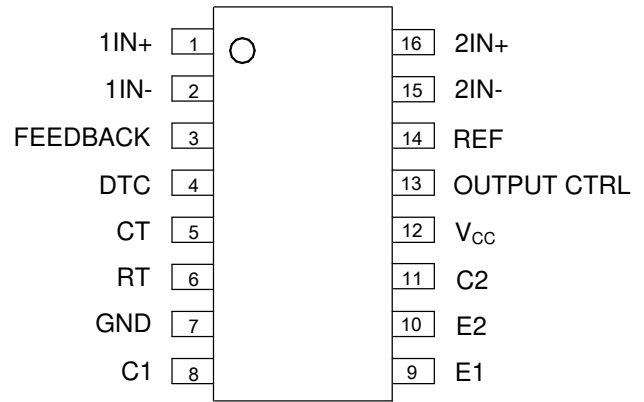

SO-16

Features

- Stable 4.95V/5V Reference Voltage Trimmed to $\pm 1.0\%$ Accuracy
- Uncommitted Output TR for 200mA Sink or Source Current
- Single-End or Push-Pull Operation Selected by Output Control
- Internal Circuitry Prohibits Double Pulse at Either Output
- Complete PWM Control Circuit with Variable Duty Cycle
- On-Chip Oscillator with Master or Slave Operation
- **Totally Lead-Free & Fully RoHS Compliant (Notes 1 & 2)**
- **Halogen and Antimony Free. "Green" Device (Note 3)**

(Top View)

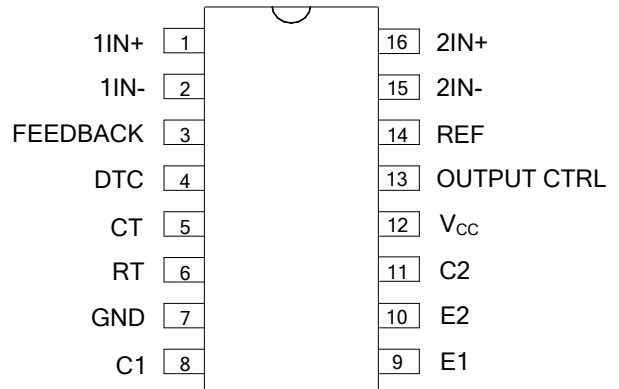

PDIP-16

Applications

- SMPS
- Back Light Inverter
- Charger

Notes: 1. No purposely added lead. Fully EU Directive 2002/95/EC (RoHS) & 2011/65/EU (RoHS 2) compliant.
2. See http://www.diodes.com/quality/lead_free.html for more information about Diodes Incorporated's definitions of Halogen- and Antimony-free, "Green" and Lead-free.
3. Halogen- and Antimony-free "Green" products are defined as those which contain <900ppm bromine, <900ppm chlorine (<1500ppm total Br + Cl) and <1000ppm antimony compounds.

Output Function Control Table

Signal for Output Control	Output Function
$V_I = \text{GND}$	Single-ended or parallel output
$V_I = V_{\text{REF}}$	Normal push-pull operation

Typical Applications Circuit

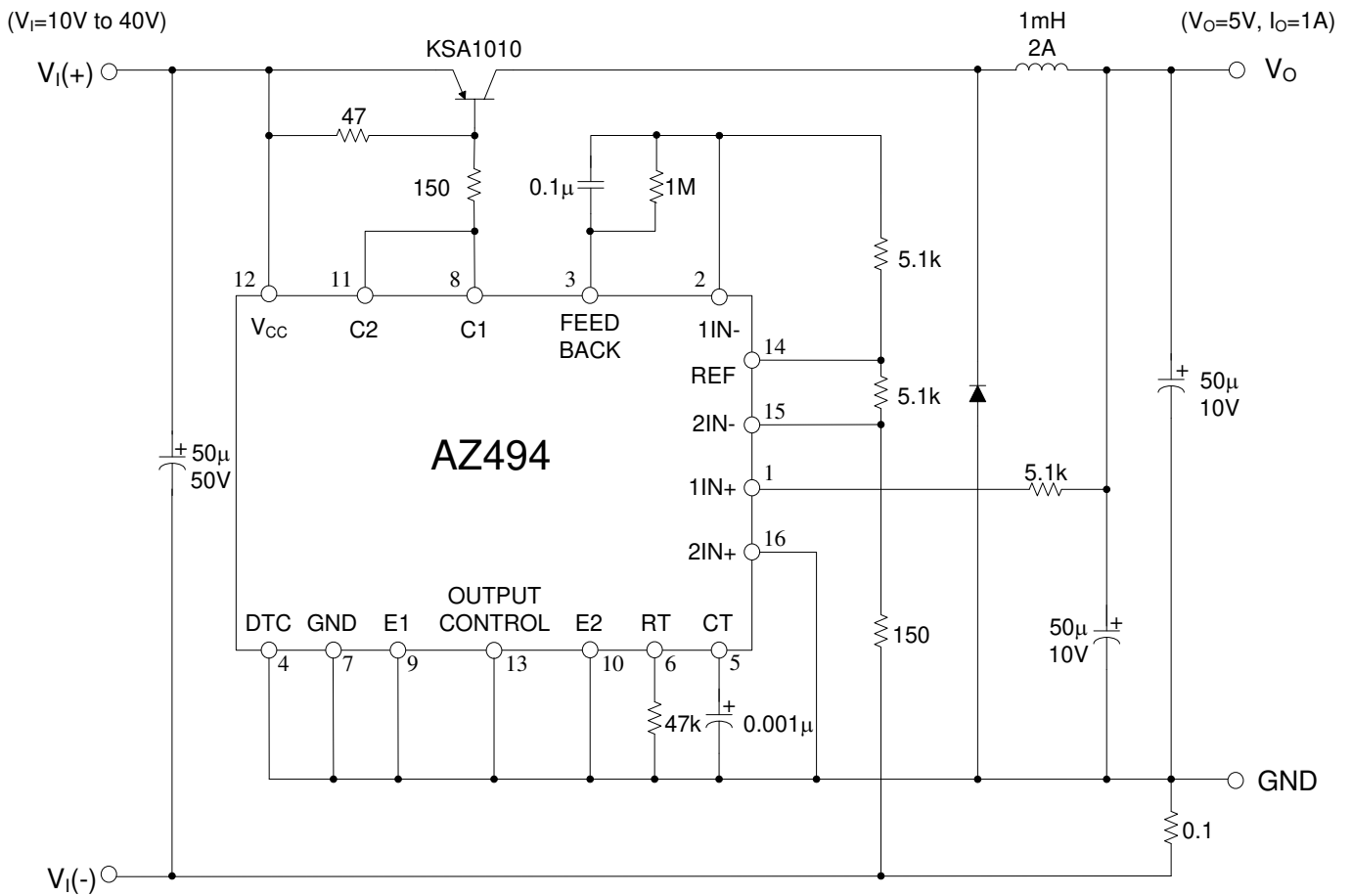

Pulse Width Modulated Step-Down Converter

NEW PRODUCT

Functional Block Diagram

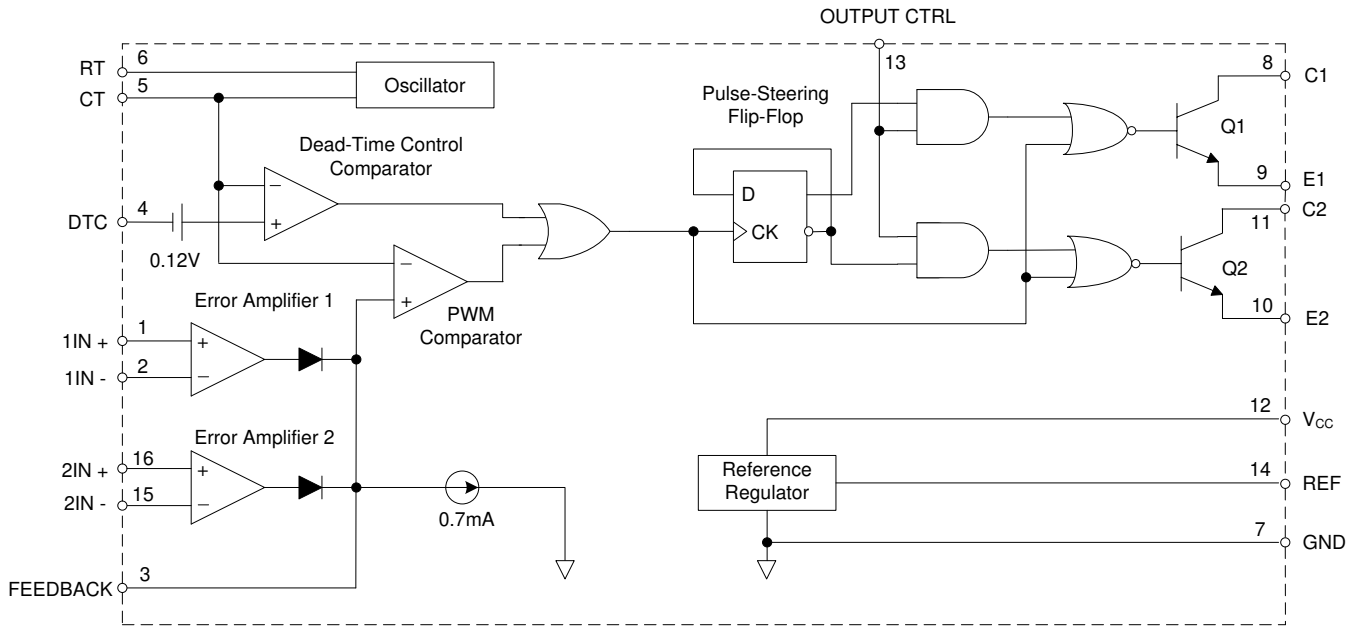

Absolute Maximum Ratings (Note 4)

Symbol	Parameter	Rating	Unit
V _{CC}	Supply Voltage (Note 5)	40	V
V _I	Amplifier Input Voltage	-0.3 to V _{CC} + 0.3	V
V _O	Collector Output Voltage	40	V
I _O	Collector Output Current	250	mA
θ _{JA}	Package Thermal Impedance (Note 6)	M Package	73
		P Package	67
-	Lead Temperature 1.6mm from case for 10 seconds	+260	°C
T _{STG}	Storage Temperature Range	-65 to +150	°C
-	ESD Rating (Machine Model)	200	V

Notes: 4. Stresses greater than those listed under "Absolute Maximum Ratings" may cause permanent damage to the device. These are stress ratings only, and functional operation of the device at these or any other conditions beyond those indicated under "Recommended Operating Conditions" is not implied. Exposure to "Absolute Maximum Ratings" for extended periods may affect device reliability.

5. All voltage values are with respect to the network ground terminal.

6. Maximum power dissipation is a function of T_{J(max)}, θ_{JA} and T_A. The maximum allowable power dissipation at any allowable ambient temperature is P_D = (T_{J(max)} - T_A) / θ_{JA}. Operating at the absolute maximum T_J of +150°C can affect reliability.

Recommended Operating Conditions

Symbol	Parameter	Min	Typ	Max	Unit
V _{CC}	Supply Voltage	7	15	36	V
V _{C1} , V _{C2}	Collector Output Voltage	–	30	36	V
I _{C1} , I _{C2}	Collector Output Current(Each Transistor)	–	–	200	mA
V _I	Amplifier Input Voltage	0.3	–	V _{CC} - 2	V
I _{FB}	Current Into Feedback Terminal	–	–	0.3	mA
I _{REF}	Reference Output Current	–	–	10	mA
C _T	Timing Capacitor	0.00047	0.001	10	μF
R _T	Timing Resistor	1.8	30	500	kΩ
f _{osc}	Oscillator Frequency	1.0	40	200	kHz
–	PWM Input Voltage (Pin 3, 4, 14)	0.3	–	5.3	V
T _A	Operating Free-Air Temperature	-40	–	+85	°C

Electrical Characteristics (T_A=+25°C, V_{CC}=20V, f=10kHz, unless otherwise noted.)

Symbol	Parameter	Conditions	Min	Typ	Max	Unit
Reference Section						
V _{REF}	Output Reference Voltage for AZ494A	I _{REF} =1mA	4.90	4.95	5.0	V
		I _{REF} =1mA, T _A = -40 to +85°C	4.85	4.95	5.05	V
V _{REF}	Output Reference Voltage for AZ494C	I _{REF} =1mA	4.95	5.0	5.05	V
		I _{REF} =1mA, T _A = -40 to +85°C	4.9	5.0	5.1	V
R _{LINE}	Line Regulation	V _{CC} = 7V to 36V	–	2	25	mV
R _{LOAD}	Load Regulation	I _{REF} =1mA to 10mA	–	1	15	mV
I _{SC}	Short-Circuit Output Current	V _{REF} = 0V	10	35	50	mA
Oscillator Section						
f _{osc}	Oscillator Frequency	C _T =0.001μF, R _T =30kΩ	–	40	–	kHz
		C _T =0.01μF, R _T =12kΩ	9.2	10	10.8	
		C _T =0.01μF, R _T =12kΩ T _A = -40 to +85°C	9.0	–	12	
Δf / ΔT	Frequency Change with Temperature	C _T =0.01μF, R _T =12kΩ T _A = -40 to +85°C	–	–	1	%

Electrical Characteristics ($T_A=+25^{\circ}\text{C}$, $V_{CC}=20\text{V}$, $f=10\text{kHz}$ unless otherwise noted.) (Cont.)

Symbol	Parameter	Conditions	Min	Typ	Max	Unit	
Dead-Time Control Section							
I_{BIAS}	Input Bias Current	$V_{CC}=15\text{V}$, $V_{PIN4}= 0$ to 5.25V	-	-2	-10	μA	
$D(\text{MAX})$	Maximum Duty Cycle	$V_{CC}=15\text{V}$, $V_{PIN4}= 0\text{V}$, $V_{PIN13}= V_{REF}$	45	-	-	%	
V_{ITH}	Input Threshold Voltage	Zero Duty Cycle	-	3	3.3	V	
		Maximum Duty Cycle	0	-	-		
Error-Amplifier Section							
V_{IO}	Input Offset Voltage	$V_{PIN3} = 2.5\text{V}$	-	2	10	mV	
I_{IO}	Input Offset Current	$V_{PIN3} = 2.5\text{V}$	-	25	250	nA	
I_{BIAS}	Input Bias Current	$V_{PIN3} = 2.5\text{V}$	-	0.2	1	μA	
V_{CM}	Common-Mode Input Voltage Range	$V_{CC}=7\text{V}$ to 36V	-0.3	-	$V_{CC}-2$	V	
G_{VO}	Open-Loop Voltage Gain	$V_O = 0.5\text{V}$ to 3.5V	70	95	-	dB	
BW	Unity-Gain Bandwidth	-	-	650	-	kHz	
CMRR	Common-Mode Rejection Ratio	-	65	80	-	dB	
I_{SINK}	Output Sink Current (Feedback)	$V_{ID} = -15\text{mV}$ to -5V , $V_3 = 0.7\text{V}$	-0.3	-0.7	-	mA	
I_{SOURCE}	Output Source Current (Feedback)	$V_{ID}=15\text{mV}$ to 5V , $V_3 = 3.5\text{V}$	2	-	-	mA	
PWM Comparator Section							
V_{ITH}	Input Threshold Voltage	Zero duty cycle	-	4	4.5	V	
I_{SINK}	Input Sink Current	$V_3 = 0.7\text{V}$	-0.3	-0.7	-	mA	
Output Section							
$V_{CE}(\text{SAT})$	Output Saturation Voltage	Common Emitter	$V_E = 0\text{V}$, $I_C = 200\text{mA}$	-	1.1	1.3	V
$V_{CC}(\text{SAT})$		Emitter Follower	$V_{CC} = 15\text{V}$, $I_E = -200\text{mA}$	-	1.5	2.5	
$I_C(\text{OFF})$	Collector Off-State Current	$V_{CE} = 36\text{V}$, $V_{CC}=36\text{V}$	-	2	100	μA	
$I_E(\text{OFF})$	Emitter Off-State Current	$V_{CC} = V_C = 36\text{V}$, $V_E = 0$	-	-	-100	μA	
Total Device							
I_{CC}	Supply Current	$V_{PIN6} = V_{REF}$, $V_{CC}=15\text{V}$	-	6	10	mA	
Output Switching Characteristics							
t_R	Rise Time	Common Emitter Common Collector	-	100	200	ns	
t_F	Fall Time	Common Emitter Common Collector	-	25	100	ns	

Parameter Measurement Information

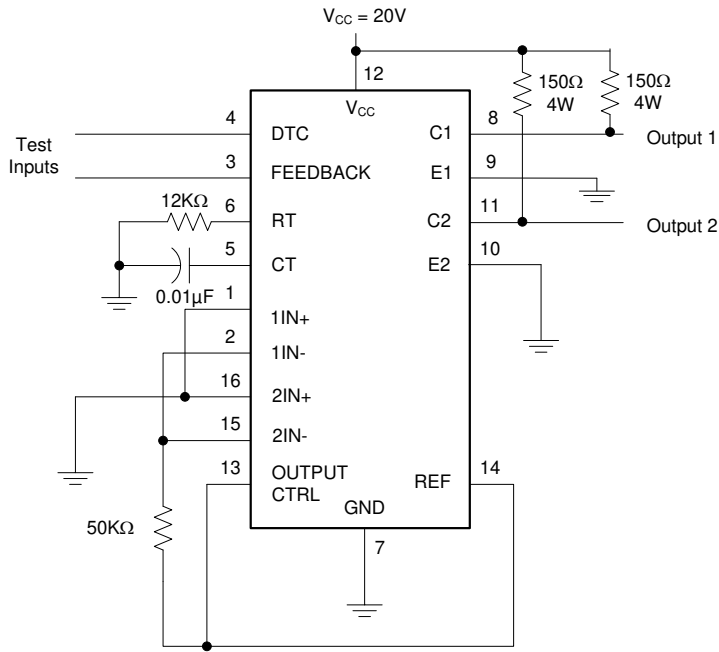

Test Circuit

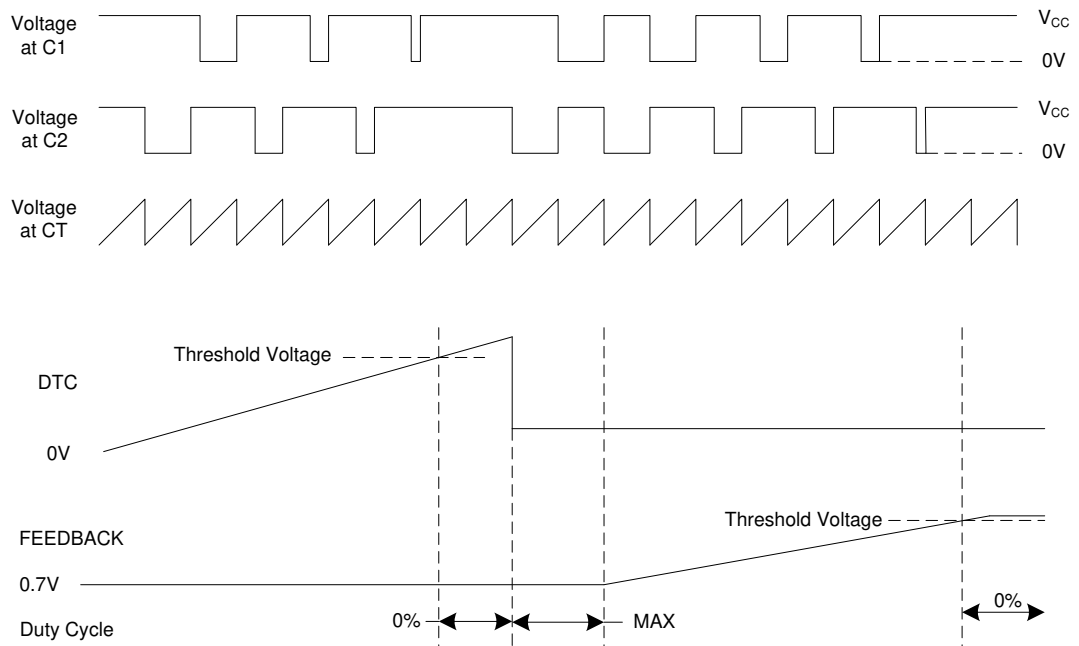

Figure 1. Operational Test Circuit and Waveforms

NEW PRODUCT

Parameter Measurement Information (Cont.)

NEW PRODUCT

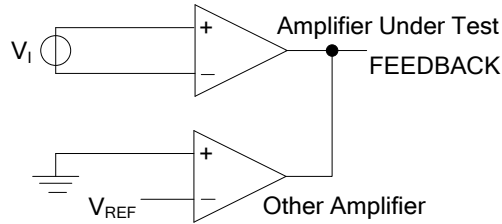
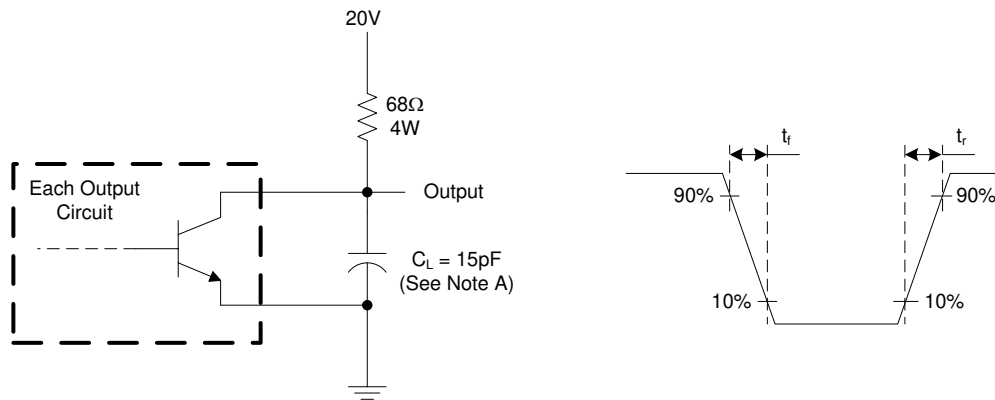
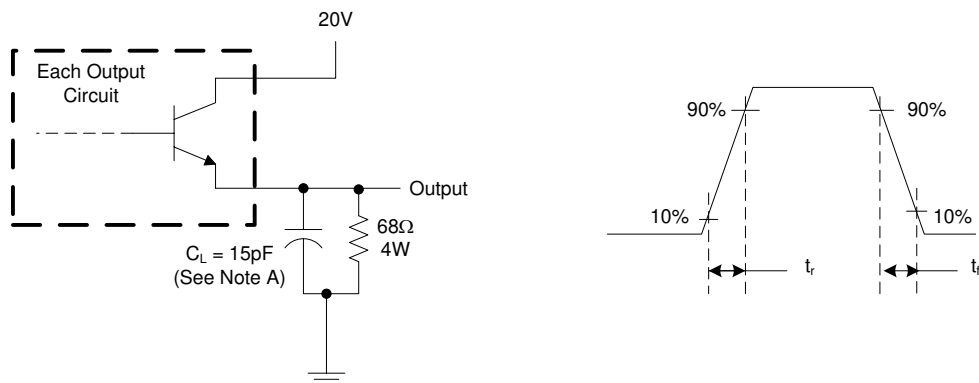

Figure 2. Error Amplifier Characteristics



Note A: C_L includes probe and jig capacitance.

Figure 3. Common-Emitter Configuration



Note A: C_L includes probe and jig capacitance.

Figure 4. Emitter-Follower Configuration

NEW PRODUCT

Performance Characteristics

Oscillator Frequency vs. RT and CT

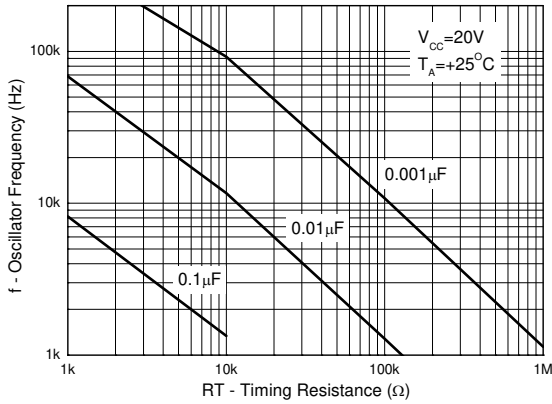

Error Amplifier Small-Signal Voltage Gain vs. Frequency

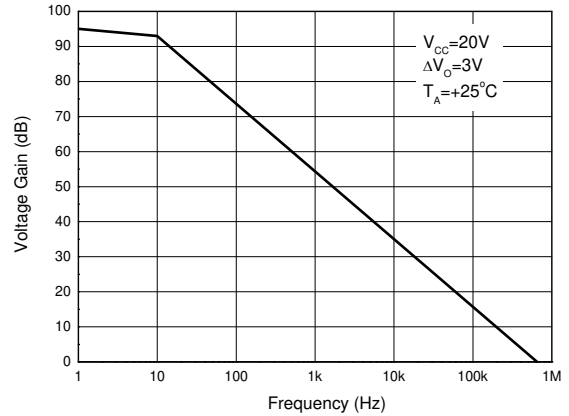

Ordering Information

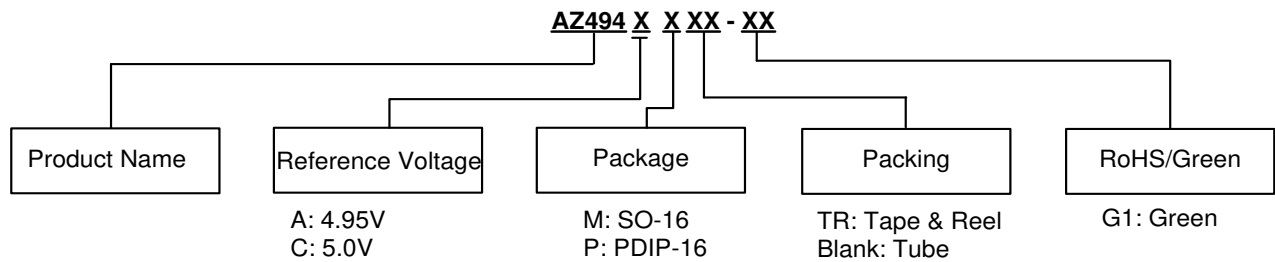

Package	Temperature Range	Part Number	Marking ID	Packing
SO-16	-40 to +85°C	AZ494CMTR-G1	AZ494CM-G1	4000/Tape & Reel
PDIP-16		AZ494AP-G1	AZ494AP-G1	25/Tube

Marking Information

PDIP-16 (Top View)

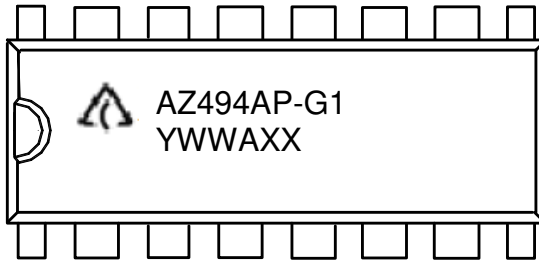

First Line: Logo and Marking ID
(See Ordering Information)
Second Line: Date Code
Y: Year
WW: Work Week of Molding
A: Assembly House Code
XX: 7th and 8th Digits of Batch No.

SO-16 (Top View)



First Line: Logo and Marking ID
(See Ordering Information)
Second Line: Date Code
Y: Year
WW: Work Week of Molding
A: Assembly House Code
XX: 7th and 8th Digits of Batch No.

Package Outline Dimensions (All dimensions in mm(inch).)

(1) Package Type: SO-16

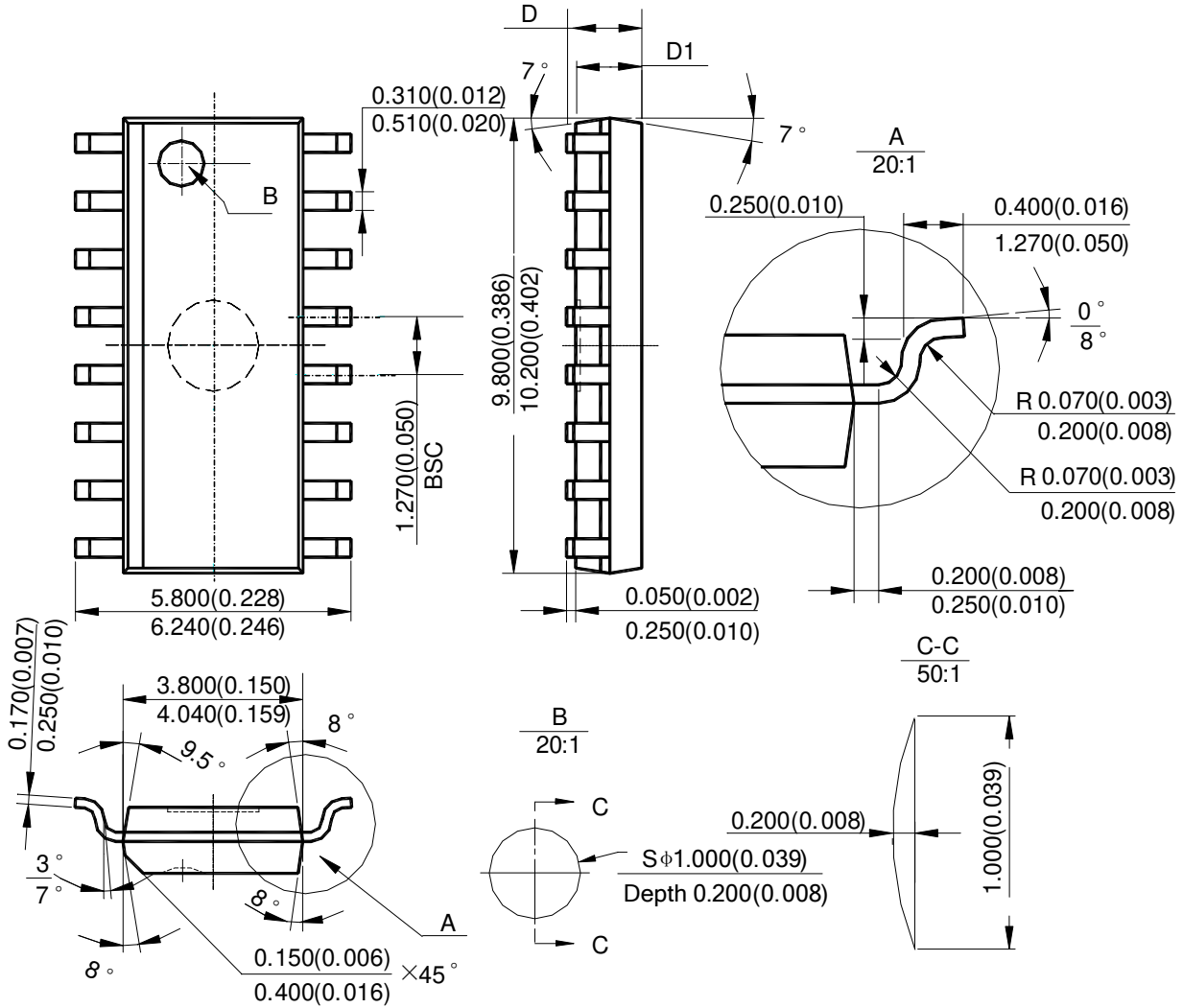

Note: Eject hole, oriented hole and mold mark is optional.

Symbol	D				D1			
	min(mm)	max(mm)	min(inch)	max(inch)	min(mm)	max(mm)	min(inch)	max(inch)
Option1	1.350	1.750	0.053	0.069	1.250	1.650	0.049	0.065
Option2	-	1.260	-	0.050	1.020	-	0.040	-

Package Outline Dimensions (All dimensions in mm(inch).) (Cont.)

(2) Package Type: PDIP-16

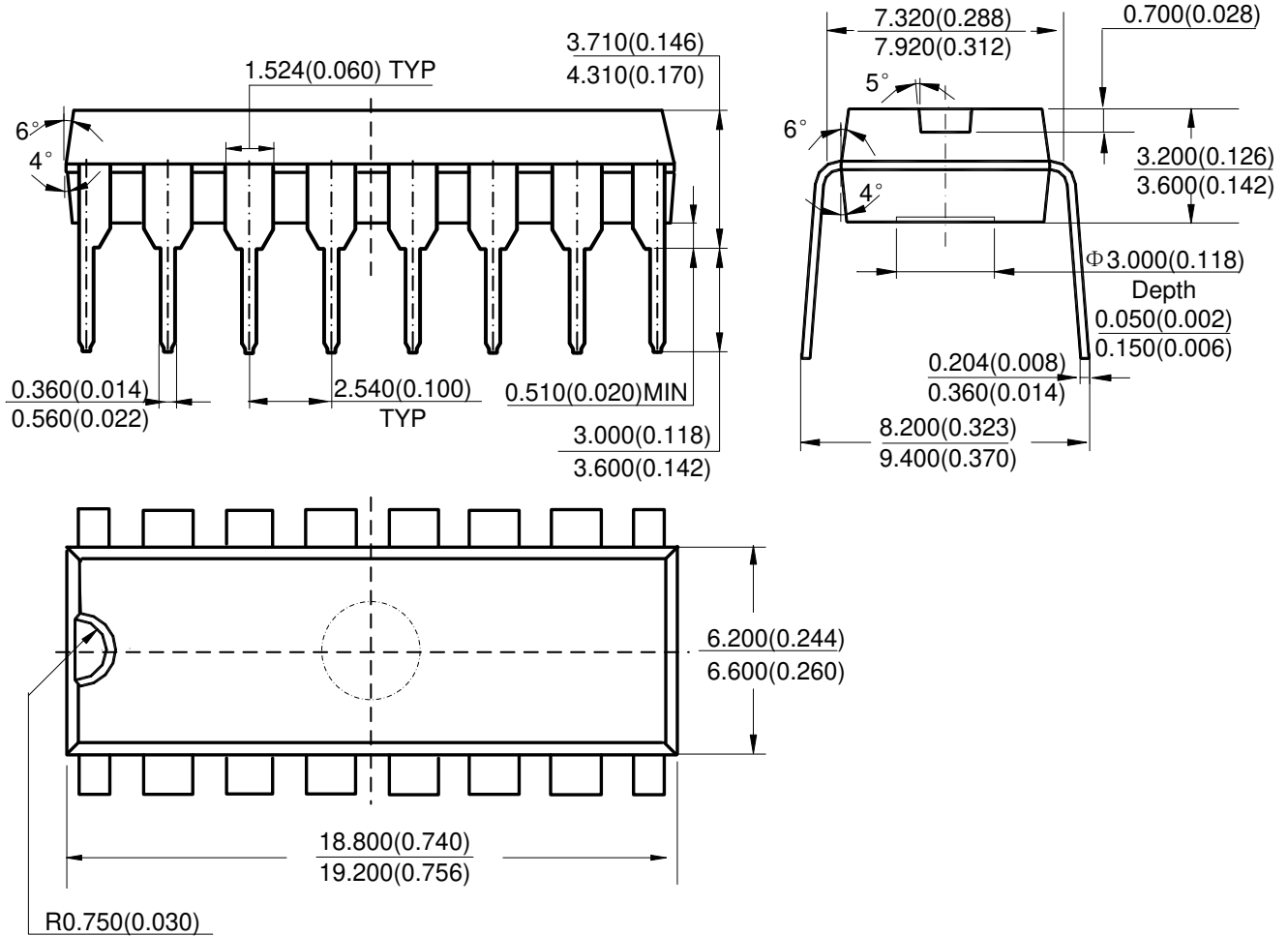

Note: Eject hole, oriented hole and mold mark is optional.

NEW PRODUCT

Suggested Pad Layout

(1) Package Type: SO-16

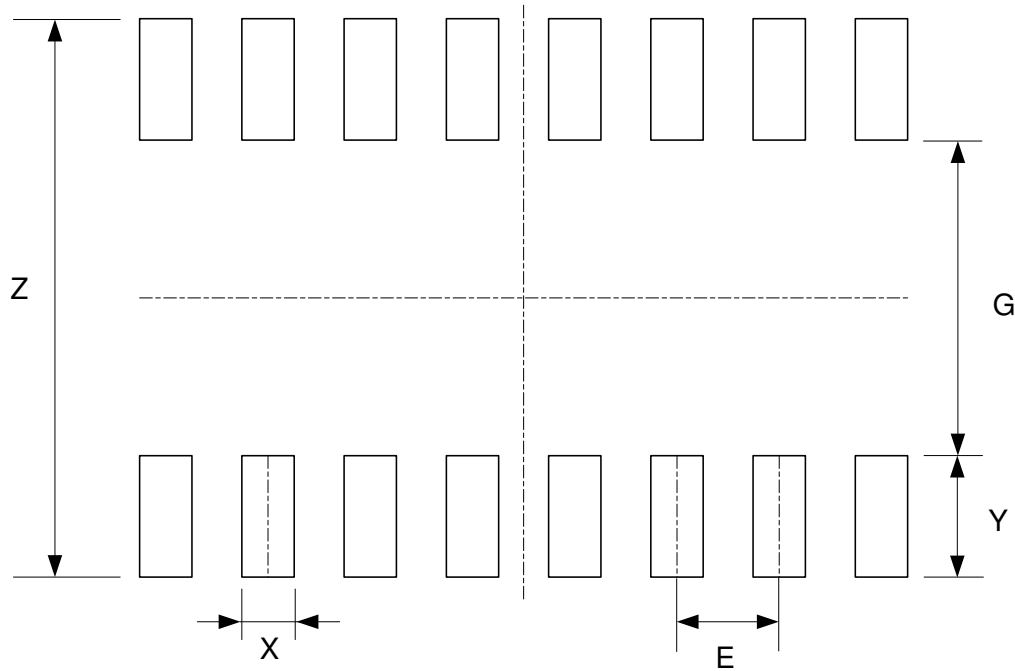

Dimensions	Z (mm)/(inch)	G (mm)/(inch)	X (mm)/(inch)	Y (mm)/(inch)	E (mm)/(inch)
Value	6.900/0.272	3.900/0.154	0.650/0.026	1.500/0.059	1.270/0.050

NEW PRODUCT

IMPORTANT NOTICE

DIODES INCORPORATED MAKES NO WARRANTY OF ANY KIND, EXPRESS OR IMPLIED, WITH REGARDS TO THIS DOCUMENT, INCLUDING, BUT NOT LIMITED TO, THE IMPLIED WARRANTIES OF MERCHANTABILITY AND FITNESS FOR A PARTICULAR PURPOSE (AND THEIR EQUIVALENTS UNDER THE LAWS OF ANY JURISDICTION).

Diodes Incorporated and its subsidiaries reserve the right to make modifications, enhancements, improvements, corrections or other changes without further notice to this document and any product described herein. Diodes Incorporated does not assume any liability arising out of the application or use of this document or any product described herein; neither does Diodes Incorporated convey any license under its patent or trademark rights, nor the rights of others. Any Customer or user of this document or products described herein in such applications shall assume all risks of such use and will agree to hold Diodes Incorporated and all the companies whose products are represented on Diodes Incorporated website, harmless against all damages.

Diodes Incorporated does not warrant or accept any liability whatsoever in respect of any products purchased through unauthorized sales channel. Should Customers purchase or use Diodes Incorporated products for any unintended or unauthorized application, Customers shall indemnify and hold Diodes Incorporated and its representatives harmless against all claims, damages, expenses, and attorney fees arising out of, directly or indirectly, any claim of personal injury or death associated with such unintended or unauthorized application.

Products described herein may be covered by one or more United States, international or foreign patents pending. Product names and markings noted herein may also be covered by one or more United States, international or foreign trademarks.

This document is written in English but may be translated into multiple languages for reference. Only the English version of this document is the final and determinative format released by Diodes Incorporated.

LIFE SUPPORT

Diodes Incorporated products are specifically not authorized for use as critical components in life support devices or systems without the express written approval of the Chief Executive Officer of Diodes Incorporated. As used herein:

A. Life support devices or systems are devices or systems which:

1. are intended to implant into the body, or
2. support or sustain life and whose failure to perform when properly used in accordance with instructions for use provided in the labeling can be reasonably expected to result in significant injury to the user.

B. A critical component is any component in a life support device or system whose failure to perform can be reasonably expected to cause the failure of the life support device or to affect its safety or effectiveness.

Customers represent that they have all necessary expertise in the safety and regulatory ramifications of their life support devices or systems, and acknowledge and agree that they are solely responsible for all legal, regulatory and safety-related requirements concerning their products and any use of Diodes Incorporated products in such safety-critical, life support devices or systems, notwithstanding any devices- or systems-related information or support that may be provided by Diodes Incorporated. Further, Customers must fully indemnify Diodes Incorporated and its representatives against any damages arising out of the use of Diodes Incorporated products in such safety-critical, life support devices or systems.

Copyright © 2015, Diodes Incorporated

www.diodes.com