



Chipsmall Limited consists of a professional team with an average of over 10 year of expertise in the distribution of electronic components. Based in Hongkong, we have already established firm and mutual-benefit business relationships with customers from,Europe,America and south Asia,supplying obsolete and hard-to-find components to meet their specific needs.

With the principle of “Quality Parts,Customers Priority,Honest Operation,and Considerate Service”,our business mainly focus on the distribution of electronic components. Line cards we deal with include Microchip,ALPS,ROHM,Xilinx,Pulse,ON,Everlight and Freescale. Main products comprise IC,Modules,Potentiometer,IC Socket,Relay,Connector.Our parts cover such applications as commercial,industrial, and automotives areas.

We are looking forward to setting up business relationship with you and hope to provide you with the best service and solution. Let us make a better world for our industry!



## Contact us

Tel: +86-755-8981 8866 Fax: +86-755-8427 6832

Email & Skype: info@chipsmall.com Web: www.chipsmall.com

Address: A1208, Overseas Decoration Building, #122 Zhenhua RD., Futian, Shenzhen, China



## SPECIFICATION CONTROL DRAWING

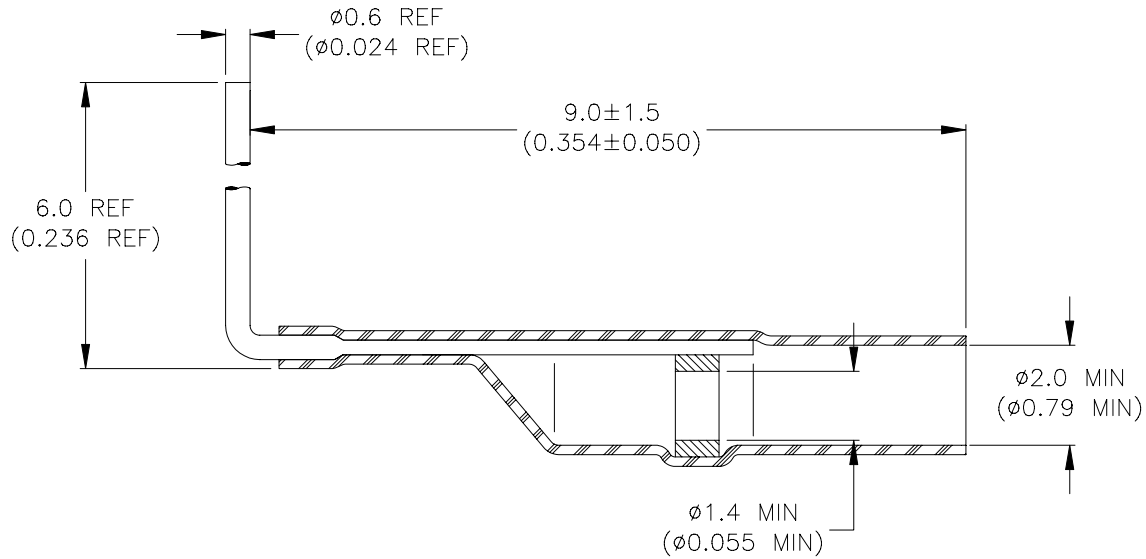

### MATERIALS

1. INSULATION SLEEVE: Heat shrinkable, transparent blue, radiation cross-linked modified polyvinylidene fluoride.
2. SOLDER PREFORM WITH FLUX:  
 SOLDER: TYPE Sn63 per ANSI J-STD-006.  
 FLUX: TYPE ROL1 per ANSI J-STD-004.
3. PIN: Phosphor bronze coated with Sn60 solder alloy.

### APPLICATION

1. This controlled soldering device facilitates the strain-relieved termination of stranded wires to printed circuit boards with 0.8mm diameter holes.
2. It will terminate the tin-plated or silver-plated copper conductor of a wire whose insulation is rated at 125°C or higher. It will handle 26, 24, and 22 AWG stranded wires.
3. For all wires, the strip length shall be  $4.0 \pm 0.5$  ( $0.157 \pm 0.020$ )
4. The recommended application tool is the AA 400 with Soldersleeve reflector. After the PinPak device is applied to the wire, the pin is cut to the desired length and hand or wave soldered to the board.

<b>Raychem Interconnect</b> <small>a division of tyco ELECTRONICS</small> 300 Constitution Drive Menlo Park, CA 94025, USA		THERMOFIT DEVICES		TITLE: <b>PCB TERMINATION PINPAK DEVICE</b>			
UNLESS OTHERWISE SPECIFIED DIMENSIONS ARE IN MILLIMETERS. INCHES DIMENSIONS ARE BETWEEN BRACKETS.				DOCUMENT NO.: <b>B-801-36</b>			
TOLERANCES: 0.00 N/A 0.0 N/A 0 N/A	ANGLES: N/A  ROUGHNESS IN MICRON	Raychem reserves the right to amend this drawing at any time. Users should evaluate the suitability of the product for their application.		DCR NUMBER: D001305		REPLACES: N/A	
DRAWN BY: M. FORONDA	DATE: 05-Dec-00	PROD. REV. E	DOC ISSUE: 1	SCALE: None	SIZE: A	SHEET: 1 of 1	

If this document is printed it becomes uncontrolled. Check for the latest revision.