



Chipsmall Limited consists of a professional team with an average of over 10 year of expertise in the distribution of electronic components. Based in Hongkong, we have already established firm and mutual-benefit business relationships with customers from,Europe,America and south Asia,supplying obsolete and hard-to-find components to meet their specific needs.

With the principle of “Quality Parts,Customers Priority,Honest Operation,and Considerate Service”,our business mainly focus on the distribution of electronic components. Line cards we deal with include Microchip,ALPS,ROHM,Xilinx,Pulse,ON,Everlight and Freescale. Main products comprise IC,Modules,Potentiometer,IC Socket,Relay,Connector.Our parts cover such applications as commercial,industrial, and automotives areas.

We are looking forward to setting up business relationship with you and hope to provide you with the best service and solution. Let us make a better world for our industry!



Contact us

Tel: +86-755-8981 8866 Fax: +86-755-8427 6832

Email & Skype: info@chipsmall.com Web: www.chipsmall.com

Address: A1208, Overseas Decoration Building, #122 Zhenhua RD., Futian, Shenzhen, China



Metallized Polyester Film Capacitors - MKT In Heat Shrinkable Tube

Construction

Dielectric: polyethylene terephthalate
Stacked-film technology
Lead spacing 5 mm

Heat shrinkable tube:
(Polyester 100µm; 125°C)

Features

Very small dimensions
Self-healing properties
High pulse strength

Terminals

Parallel wire leads, tinned
Lead spacing 5,0 mm

Marking

Manufacturer's logo,
rated capacitance (coded),
capacitance tolerance (code letter),
rated ac voltage,
date of manufacture (coded)

Delivery mode

Bulk (untaped)
Taped (Ammo pack or reel)

Detail specifications

Homologated in accordance with IEC 384-2

Straight Leads

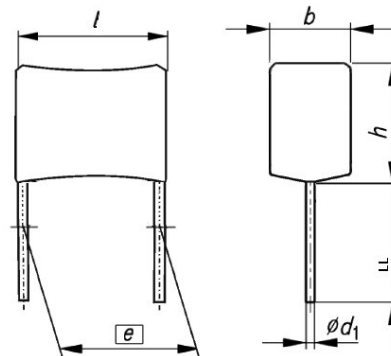

Conformed Leads "Kink"

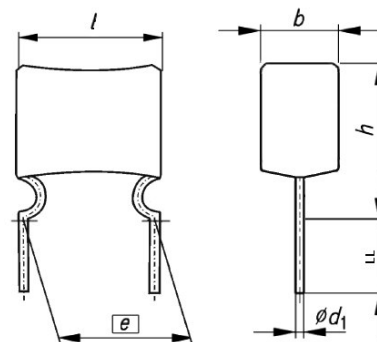

Dimensions in mm	
Lead spacing	Lead Diameter
5 ± 0,4	0,5

Ordering codes and pack units

Vr (Vrms, f ≤ 60 Hz)	CR	Maximum Dimensions ¹ (straight leads) <i>b x h x l (mm)</i>	Maximum Dimensions ² (crimped leads) <i>b x h x l (mm)</i>	Ordering code ³ (capacitance tolerance, code end)	Packing units (pcs)			
					Ammo pack	Reel pack	Untaped (bulk)	
63 Vdc (40 Vac)	0,22 µF	2,0 x 5,5 x 7,0	2,0 x 9,0 x 7,0	B32559-C0224-+***	4000	3200	3000	
	0,33 µF	2,5 x 6,0 x 7,0	2,5 x 9,5 x 7,0	B32559-C0334-+***	3200	2700	2700	
	0,47 µF	3,0 x 6,5 x 7,0	3,0 x 10,0 x 7,0	B32559-C0474-+***	2700	1900	2500	
	0,68 µF	3,0 x 8,5 x 7,0	3,0 x 12,0 x 7,0	B32559-C0684-+***	2700	1900	2000	
	1,0 µF	4,0 x 9,0 x 7,0	-	B32559-C0105-+***	2000	1700	1500	
100 Vdc (63 Vac)	33 nF	2,5 x 6,5 x 7,0	2,5 x 10,0 x 7,0	B32559-C1333-+***	3200	2800	3000	
	47 nF	2,5 x 6,5 x 7,0	2,5 x 10,0 x 7,0	B32559-C1473-+***	3200	2800	3000	
	56 nF	2,5 x 6,5 x 7,0	2,5 x 10,0 x 7,0	B32559-C1563-+***	3200	2800	3000	
	68 nF	2,5 x 6,5 x 7,0	2,5 x 10,0 x 7,0	B32559-C1683-+***	3200	2800	3000	
	0,1 µF	2,5 x 6,5 x 7,0	2,5 x 10,0 x 7,0	B32559-C1104-+***	3200	2800	3000	
	0,12 µF	2,5 x 6,5 x 7,0	2,5 x 10,0 x 7,0	B32559-C1124-+***	3200	2800	3000	
	0,15 µF	2,5 x 6,5 x 7,0	2,5 x 10,0 x 7,0	B32559-C1154-+***	3200	2800	3000	
	0,22 µF	2,5 x 7,0 x 7,0	2,5 x 10,5 x 7,0	B32559-C1224-+***	3200	2800	2800	
	0,33 µF	3,0 x 8,0 x 7,0	3,0 x 11,5 x 7,0	B32559-C1334-+***	2700	2200	2200	
	0,47 µF	3,5 x 8,0 x 7,0	3,5 x 11,5 x 7,0	B32559-C1474-+***	2300	1700	1700	
	250 Vdc (160 Vac)	22 nF	2,5 x 6,5 x 7,0	2,5 x 10,0 x 7,0	B32559-C3223-+***	3200	2800	3000
27 nF		2,5 x 6,5 x 7,0	2,5 x 10,0 x 7,0	B32559-C3223-+***	3200	2800	3000	
33 nF		2,5 x 6,5 x 7,0	2,5 x 10,0 x 7,0	B32559-C3333-+***	3200	2800	3000	
47 nF		2,5 x 6,5 x 7,0	2,5 x 10,0 x 7,0	B32559-C3473-+***	3200	2800	3000	
56 nF		2,5 x 6,5 x 7,0	2,5 x 10,0 x 7,0	B32559-C3563-+***	3200	2800	3000	
68 nF		3,0 x 7,0 x 7,0	3,0 x 10,5 x 7,0	B32559-C3683-+***	2700	2200	2500	
82 nF		3,0 x 8,0 x 7,0	3,0 x 11,5 x 7,0	B32559-C3823-+***	2700	2200	2200	
0,1 µF		3,0 x 8,5 x 7,0	3,0 x 12,0 x 7,0	B32559-C3104-+***	2700	2200	2000	
0,12 µF		3,5 x 8,5 x 7,0	-	B32559-C3124-+***	2300	1700	1500	
0,15 µF		4,5 x 8,5 x 7,0	-	B32559-C3154-+***	1800	1500	1500	
400 Vdc (200 Vac)		6,8 nF	2,5 x 6,5 x 7,0	2,5 x 10,0 x 7,0	B32559-C6682-+***	3200	2800	3000
		8,2 nF	2,5 x 6,5 x 7,0	2,5 x 10,0 x 7,0	B32559-C6822-+***	3200	2800	3000
	10 nF	2,5 x 6,5 x 7,0	2,5 x 10,0 x 7,0	B32559-C6103-+***	3200	2800	3000	
	12 nF	2,5 x 6,5 x 7,0	2,5 x 10,0 x 7,0	B32559-C6123-+***	3200	2800	3000	
	15 nF	2,5 x 6,5 x 7,0	2,5 x 10,0 x 7,0	B32559-C6153-+***	3200	2800	3000	
	22 nF	2,5 x 6,5 x 7,0	2,5 x 10,0 x 7,0	B32559-C6223-+***	3200	2800	3000	
	27 nF	2,5 x 7,0 x 7,0	2,5 x 10,5 x 7,0	B32559-C6273-+***	3200	2800	2800	
	33 nF	3,0 x 7,0 x 7,0	3,0 x 10,5 x 7,0	B32559-C6333-+***	2700	2300	2500	
	47 nF	3,5 x 7,0 x 7,0	3,5 x 10,5 x 7,0	B32559-C6473-+***	2300	1900	2500	
	56 nF	4,0 x 7,5 x 7,0	-	B32559-C6563-+***	2000	1700	1700	
	68 nF	4,5 x 8,0 x 7,0	-	B32559-C6683-+***	1800	1500	1500	
	0,1 µF	5,5 x 10,0 x 7,0	-	B32559-C6104-+***	1400	1100	1000	
	0,12 µF	5,5 x 11,0 x 7,0	-	B32559-C6124-+***	1400	1100	1000	
	630 Vdc (400 Vac)	1,0 nF	3,0 x 7,0 x 7,0	3,0 x 10,5 x 7,0	B32559-C8102-+***	2700	2300	2500
		1,5 nF	3,0 x 7,0 x 7,0	3,0 x 10,5 x 7,0	B32559-C8152-+***	2700	2300	2500
2,2 nF		3,0 x 7,0 x 7,0	3,0 x 10,5 x 7,0	B32559-C8222-+***	2700	2300	2500	
2,7 nF		3,5 x 7,5 x 7,0	3,5 x 11,0 x 7,0	B32559-C8272-+***	2300	1900	2000	
3,3 nF		3,5 x 7,5 x 7,0	3,5 x 11,0 x 7,0	B32559-C8332-+***	2300	1900	2000	
4,7 nF		3,5 x 8,0 x 7,0	3,5 x 11,5 x 7,0	B32559-C8472-+***	2300	1900	2000	
6,8 nF		3,5 x 8,0 x 7,0	3,5 x 11,5 x 7,0	B32559-C8682-+***	2300	1900	2000	
8,2 nF		3,5 x 8,0 x 7,0	3,5 x 11,5 x 7,0	B32559-C8822-+***	2300	1900	2000	
10 nF		3,5 x 8,0 x 7,0	3,5 x 11,5 x 7,0	B32559-C8103-+***	2300	1900	2000	

¹ Straight leads; ² Conformed leads "Kink". ³ Replace the + by the code letter for the required capacitance tolerance. **Capacitance tolerance:** ±20 % = M, ±10 % = K, ±5 % = J.

Code end: Replace the *** by the code number for the required lead length or packing:

000 = lead length 6 mm (untaped bulk "kink" wire); **001** = lead length 6mm (untaped bulk straight lead); **289** = taped, Ammo pack ("kink" leads); **489** = taped, Ammo pack (straight leads).

Technical Data

Climatic category in accordance with IEC 68-1 Lower category temperature T _{min} Upper category temperature T _{max} Damp heat test Limit values after damp heat test	55/125/56 - 55 °C + 125 °C 56 days/40 °C/93 % relative humidity Capacitance change ΔC/C ≤ 5 % Dissipation factor change Δ tan δ ≤ 5 · 10 ⁻³ (at 1 kHz) Insulation resistance R _{is} ≥ 50 % of minimum or time constant τ = C _R · R _{is} as-delivered values		
Reliability: Reference conditions Failure rate Service life Failure criteria: Total failure Failure due to variation of parameters	0,5 · Vr ; 40 °C 1 · 10 ⁻⁹ / h = 1 fit 200 000 h Short circuit or open circuit Capacitance change ΔC/C > 10% Dissipation factor tan δ 2 · upper limit value Insulation resistance Ris < 150 MΩ (Cr ≤ 0,33μF) Or time constant τ = Cr · Ris < 50s (Cr > 0,33μF)		
DC test voltage	1,4 · Vr, 2s		
Category voltage Vc Operation with dc voltage or ac voltage Vrms up to 60 Hz	T _A (°C)	DC voltage derating	AC voltage derating
	T _A ≤ 85 85 < T _A ≤ 125	V _C = V _R V _C = V _R · (165 - T _A) / 80	V _{C,rms} = V _{rms} V _{C,rms} = V _{rms} · (165 - T _A) / 80
Operating voltage for short operating periods	T _A (°C)	DC voltage (max. hours)	AC voltage (max hours)
	T _A ≤ 100 100 < T _A ≤ 125	V _{op} = 1.25 · V _C (2000h) V _{op} = 1.25 · V _C (1000h)	V _{op} = 1.0 · V _{C,rms} · (2000h) V _{op} = 1.0 · V _{C,rms} · (1000h)
Dissipation factor tan δ (in 10 ⁻³) at 20 °C (upper limit values)	at 1 kHz 10 kHz 100 kHz	C _R ≤ 0,1 μF 8 15 30	0,1 μF < C _R ≤ 1 μF 10 20 -
Insulation resistance R _{is} or time constant τ = C _R · R _{is} at 20 °C, rel. humidity ≤ 65 % (minimum as-delivered values)	V _R ≤ 100 Vdc ≥ 250 Vdc	C _R ≤ 0,33 μF 3750 MΩ 7500 MΩ	

Pulse Handling capability

V _R	Max. rate of voltage rise Vpp/τ in V/μs (for Vpp = Vr)
63 Vdc	250
100 Vdc	300
250 Vdc	400
400 Vdc	600
630 Vdc	800

V _R	Pulse characteristic ko in V ² /μs (for Vpp ≤ Vr)
----------------	--

63 Vdc	30 000
100 Vdc	60 000
250 Vdc	200 000
400 Vdc	500 000
630 Vdc	1 000 000

Soldering conditions

Maximum solder bath temperature: 245 °C
Maximum soldering time: 4s

Impedance Z versus frequency f (typical values)

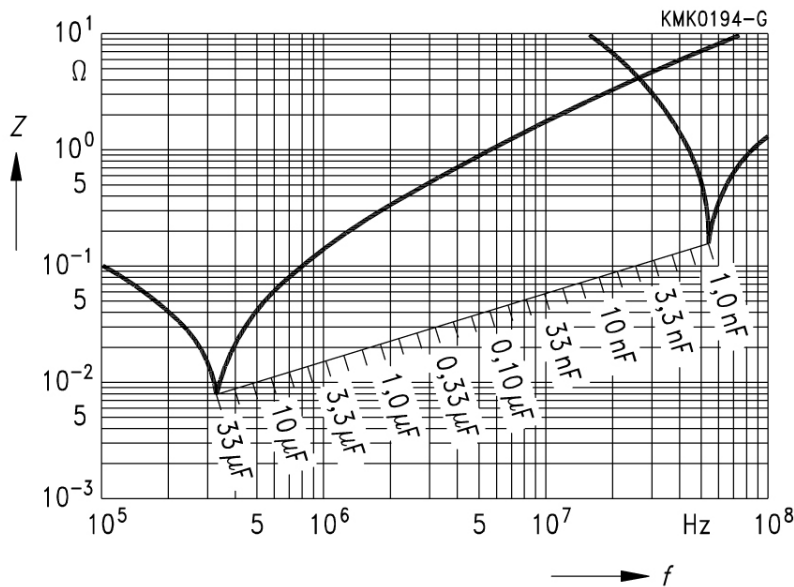

Permissible ac voltage V_{rms} versus frequency f

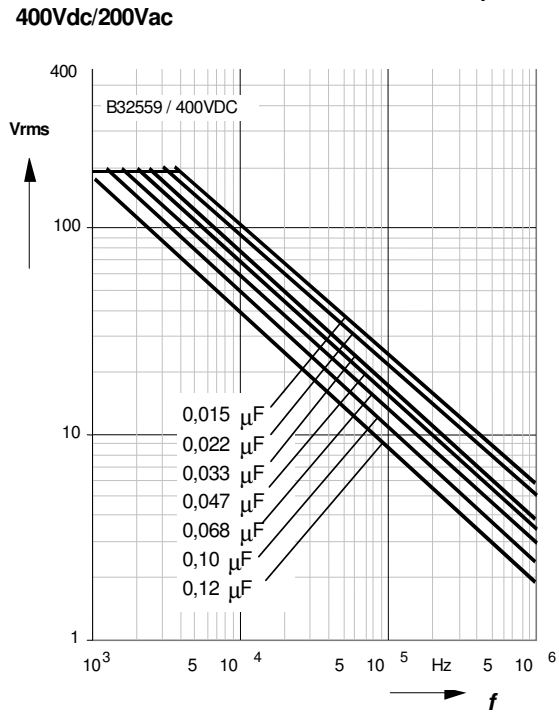
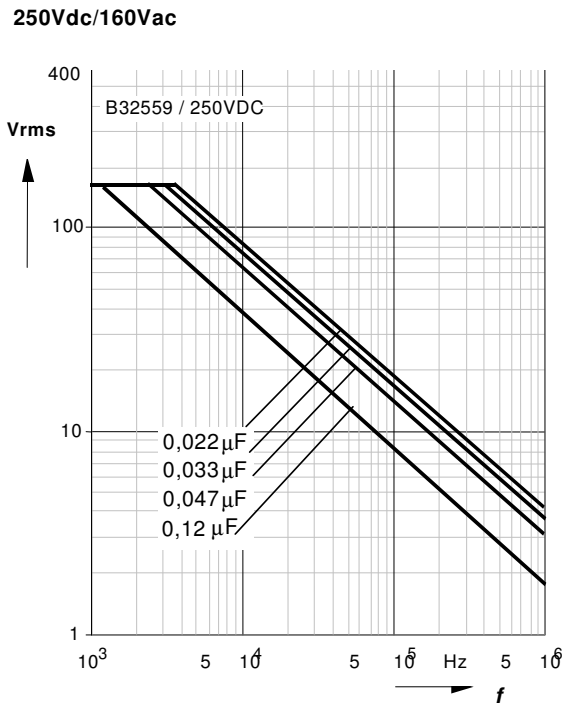
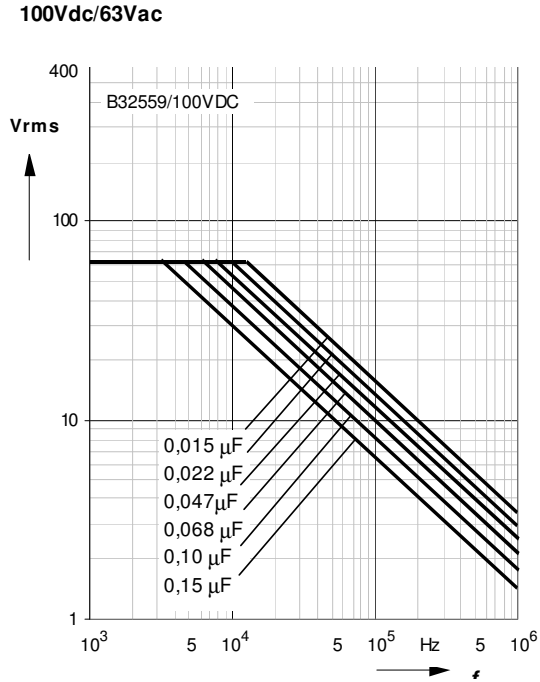
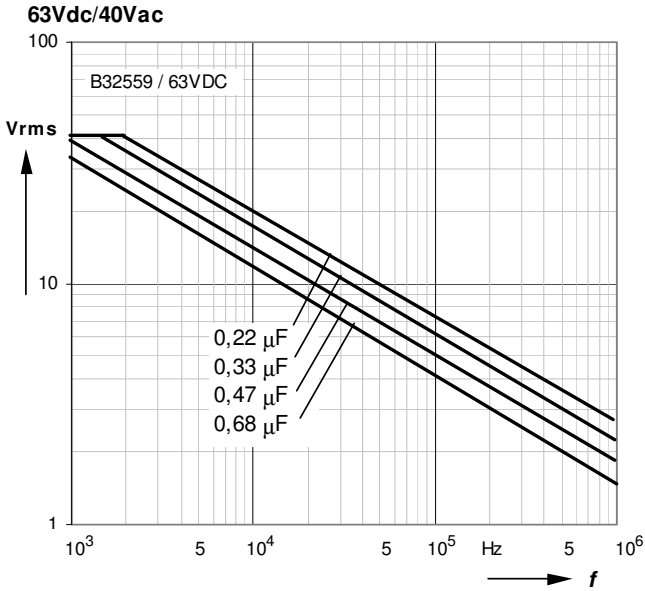

630Vdc/400Vac

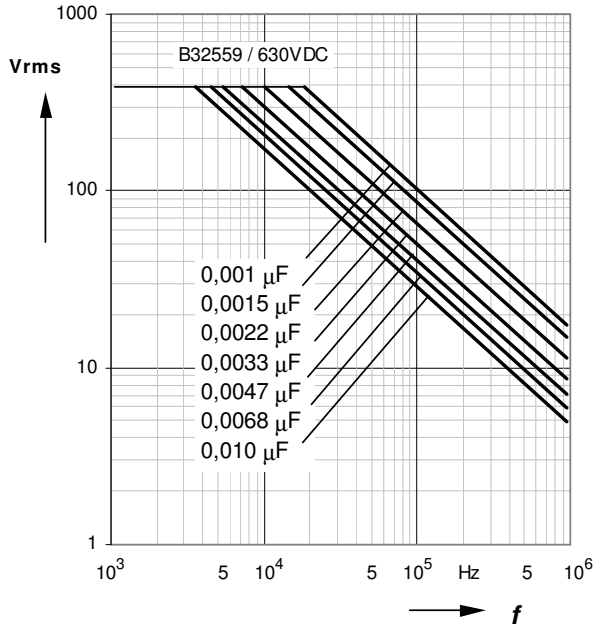

Permissible ac current I_{rms} versus frequency f

63Vdc/40Vac

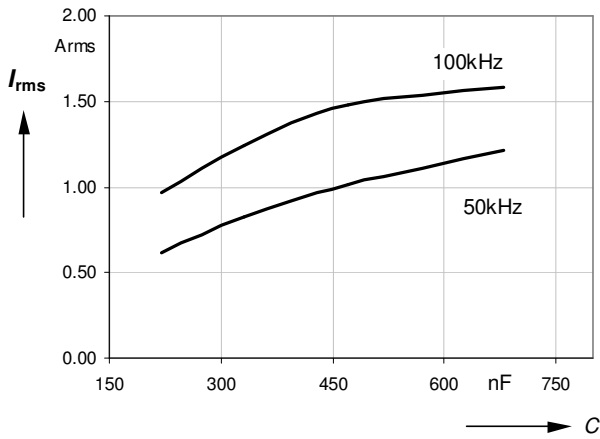

100Vdc/63Vac

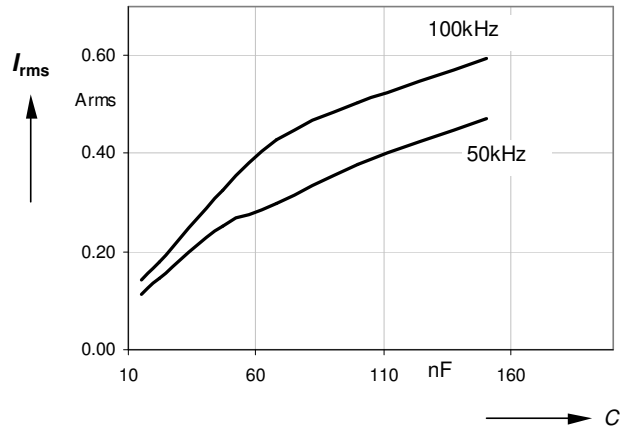

250Vdc/160Vac

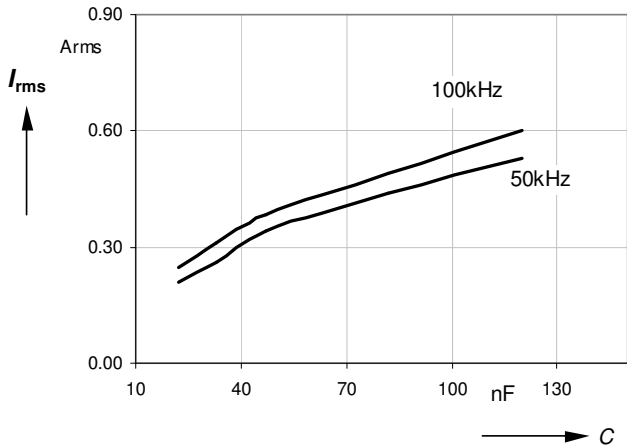

400Vdc/200Vac

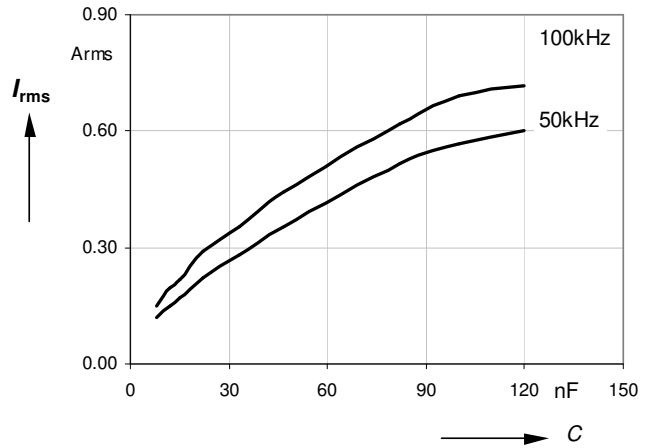

630Vdc/400Vac

