



Chipsmall Limited consists of a professional team with an average of over 10 year of expertise in the distribution of electronic components. Based in Hongkong, we have already established firm and mutual-benefit business relationships with customers from,Europe,America and south Asia,supplying obsolete and hard-to-find components to meet their specific needs.

With the principle of “Quality Parts,Customers Priority,Honest Operation,and Considerate Service”,our business mainly focus on the distribution of electronic components. Line cards we deal with include Microchip,ALPS,ROHM,Xilinx,Pulse,ON,Everlight and Freescale. Main products comprise IC,Modules,Potentiometer,IC Socket,Relay,Connector.Our parts cover such applications as commercial,industrial, and automotives areas.

We are looking forward to setting up business relationship with you and hope to provide you with the best service and solution. Let us make a better world for our industry!



## Contact us

Tel: +86-755-8981 8866 Fax: +86-755-8427 6832

Email & Skype: info@chipsmall.com Web: www.chipsmall.com

Address: A1208, Overseas Decoration Building, #122 Zhenhua RD., Futian, Shenzhen, China





# *SAW Components*

*Data Sheet B7731*



**Features**

- Low-loss RF filter for mobile telephone cellular system, receive path
- Low amplitude ripple
- Usable passband 25 MHz
- Unbalanced to balanced operation
- Impedance transformation from 50  $\Omega$  to 100  $\Omega$
- Package for **Surface Mounted Technology (SMT)**

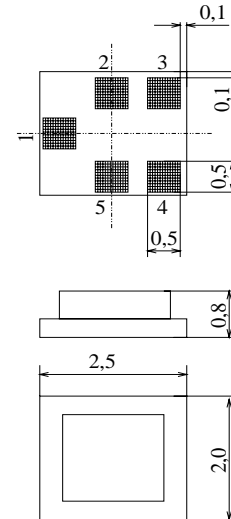
**Chip Size SAW package QCS5A**

Dimensions in mm, approx. weight 0,015g

**Terminals**

- Ni, gold-plated

**Pin configuration**

- |     |                   |
|-----|-------------------|
| 1   | Input, unbalanced |
| 3,4 | Balanced output   |
| 2,5 | Case ground       |

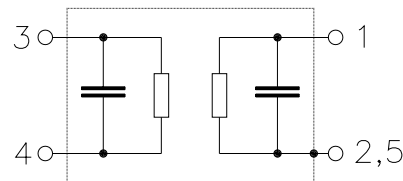

Type	Ordering code	Marking and Package according to	Packing according to
B7731	B39881-B7731-B610	C61157-A7-A71	F61074-V8153-Z000

Electrostatic Sensitive Device (ESD)

**Maximum ratings**

Operable temperature range	$T$	- 30 / + 85	$^{\circ}\text{C}$	source impedance 50 $\Omega$ CDMA signal
Storage temperature range	$T_{\text{stg}}$	- 40 / + 85	$^{\circ}\text{C}$	
DC voltage	$V_{\text{DC}}$	5	V	
Input power max.	$P_{\text{IN}}$	0	dBm	



SAW Components

B7731

Low-Loss Filter for Mobile Communication

881,5 MHz

Data Sheet



**Characteristics**

Operating temperature range:  $T = -30$  to  $+85$  °C  
 Terminating source impedance:  $Z_S = 50 \Omega$   
 Terminating load impedance:  $Z_L = 100 \Omega$

			min.	typ.	max.	
<b>Center frequency</b>	$f_C$		—	881,5	—	MHz
<b>Maximum insertion attenuation</b>	$\alpha_{max}$					
	869,0 ... 894,0 MHz		—	2,4	3,0	dB
<b>Amplitude ripple (p-p)</b>	$\Delta\alpha$					
	869,0 ... 894,0 MHz		—	1,0	1,6	dB
<b>Input VSWR</b>						
	869,0 ... 894,0 MHz		—	1,9	2,0	
<b>Output VSWR</b>						
	869,0 ... 894,0 MHz		—	2,0	2,1	
<b>Attenuation</b>	$\alpha$					
	0,0 ... 824,0 MHz		55,0	64,0	—	dB
	824,0 ... 849,0 MHz		33,0	50,0	—	dB
	915,0 ... 1000,0 MHz		25,0	31,0	—	dB
	1000,0 ... 1610,0 MHz		55,0	63,0	—	dB
	1610,0 ... 3000,0 MHz		50,0	64,0	—	dB
	3000,0 ... 6000,0 MHz		45,0	68,0	—	dB
<b>Amplitude Imbalance</b>			-0,8	—	0,8	dB
<b>Phase Imbalance</b>			-4,5	—	3,5	degree



Transfer function

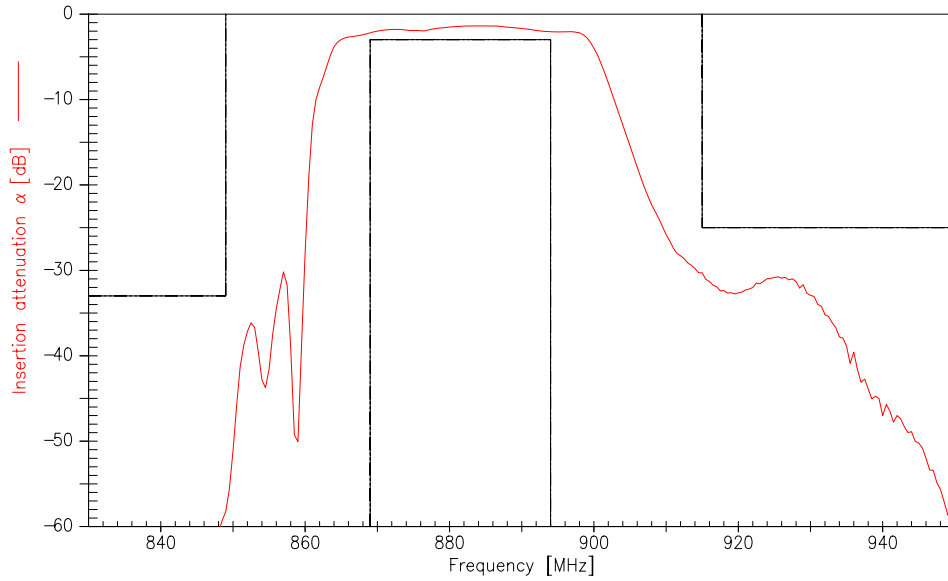

Transfer function (wideband)

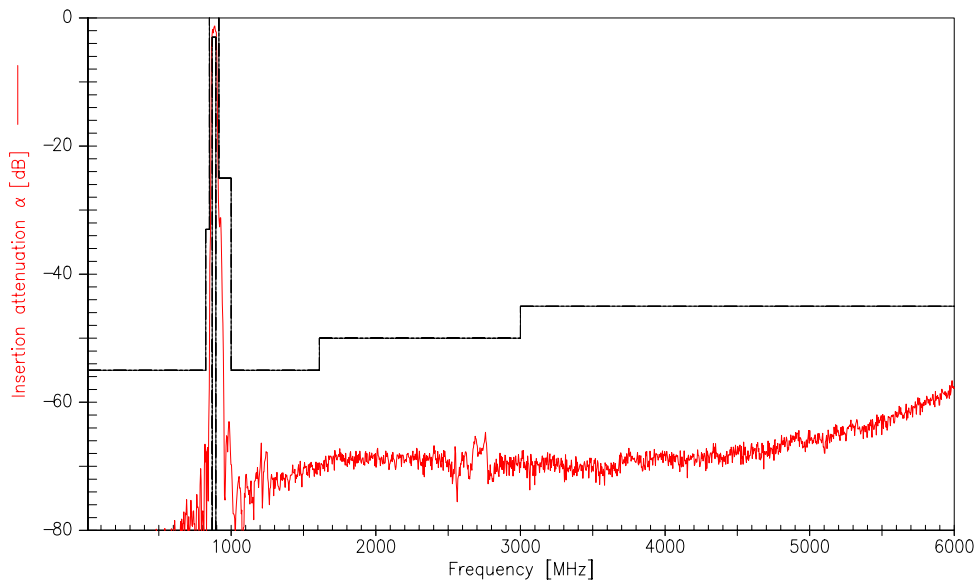



$S_{11}$

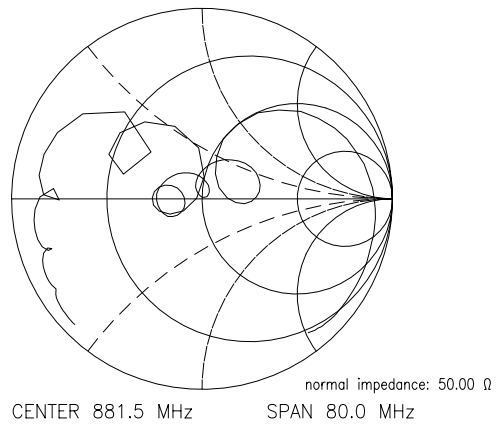
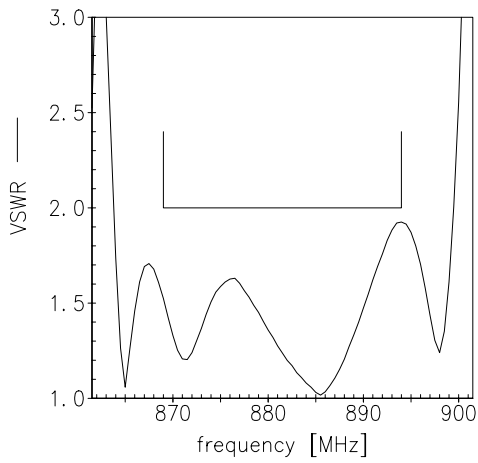

$S_{22}$

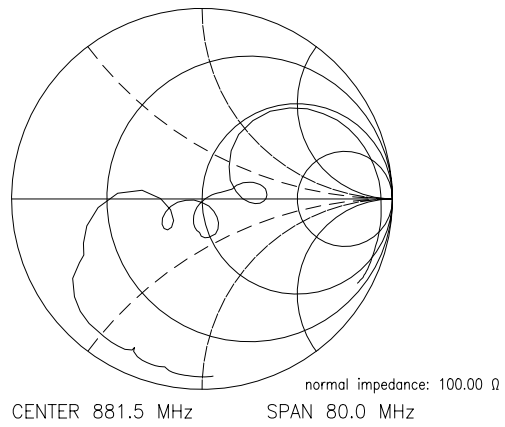
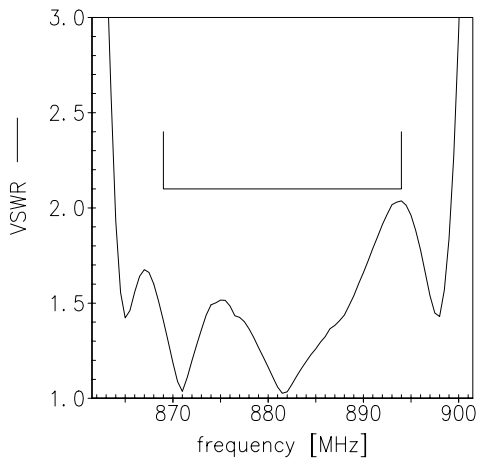

**Amplitude imbalance**

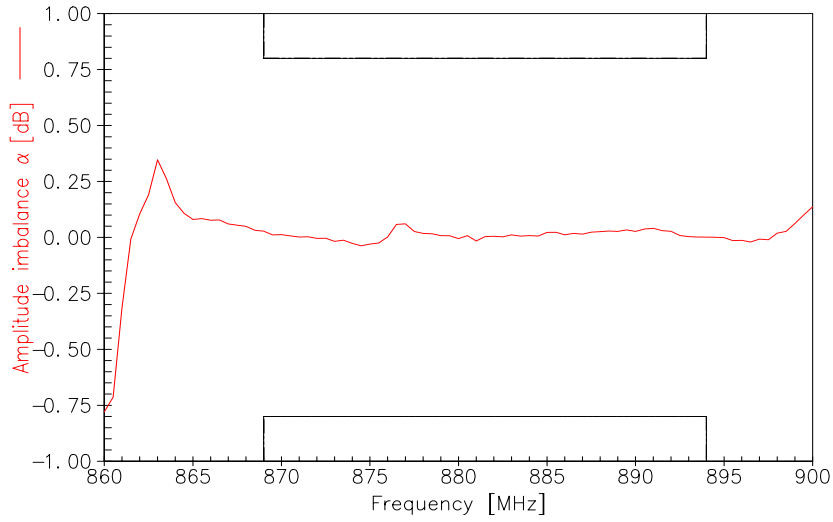

**Phase imbalance**

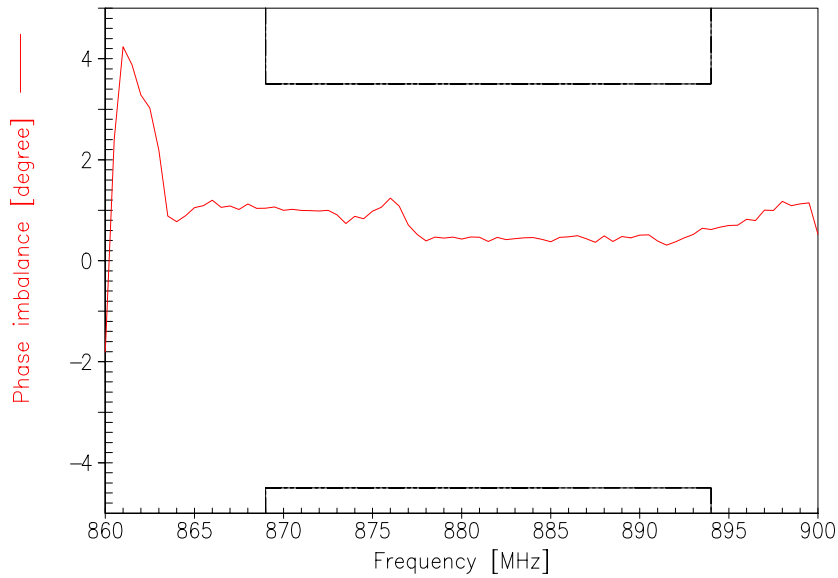



**SAW Components**

**B7731**

**Low-Loss Filter for Mobile Communication**

**881,5 MHz**

Data Sheet



**Published by EPCOS AG**

**Surface Acoustic Wave Components Division, SAW MC WT**

**P.O. Box 80 17 09, 81617 Munich, GERMANY**

© EPCOS AG 2002. Reproduction, publication and dissemination of this brochure and the information contained therein without EPCOS' prior express consent is prohibited.

Purchase orders are subject to the General Conditions for the Supply of Products and Services of the Electrical and Electronics Industry recommended by the ZVEI (German Electrical and Electronic Manufacturers' Association), unless otherwise agreed.

This brochure replaces the previous edition.

For questions on technology, prices and delivery please contact the Sales Offices of EPCOS AG or the international Representatives.

Due to technical requirements components may contain dangerous substances. For information on the type in question please also contact one of our Sales Offices.