



Chipsmall Limited consists of a professional team with an average of over 10 year of expertise in the distribution of electronic components. Based in Hongkong, we have already established firm and mutual-benefit business relationships with customers from,Europe,America and south Asia,supplying obsolete and hard-to-find components to meet their specific needs.

With the principle of "Quality Parts,Customers Priority,Honest Operation,and Considerate Service",our business mainly focus on the distribution of electronic components. Line cards we deal with include Microchip,ALPS,ROHM,Xilinx,Pulse,ON,Everlight and Freescale. Main products comprise IC,Modules,Potentiometer,IC Socket,Relay,Connector.Our parts cover such applications as commercial,industrial, and automotives areas.

We are looking forward to setting up business relationship with you and hope to provide you with the best service and solution. Let us make a better world for our industry!



Contact us

Tel: +86-755-8981 8866 Fax: +86-755-8427 6832

Email & Skype: info@chipsmall.com Web: www.chipsmall.com

Address: A1208, Overseas Decoration Building, #122 Zhenhua RD., Futian, Shenzhen, China





UltraCap[®]

Module
9 F/ 28 V

Series/Type:
Ordering code: B48611A5903Q012
Date: March 2005

© EPCOS AG 2005. Reproduction, publication and dissemination of this data sheet, enclosures hereto and the information contained therein without EPCOS' prior express consent is prohibited.

Purchase orders are subject to the General Conditions for the Supply of Products and Services of the Electrical and Electronics Industry recommended by the ZVEI (German Electrical and Electronic Manufacturers' Association), unless otherwise agreed.

Features

- Cable connector
- Passive cell voltage balancing
- Case material polyethylene, black
- Power type
- 12 serial single cells of 110 F
- Maintenance-free
- Short-circuit-proof
- Fast-acting blowout fuse 20 A

Note

- Please pay attention to the safety, transport and waste disposal instructions in chapter "Cautions".

Dimensional drawing

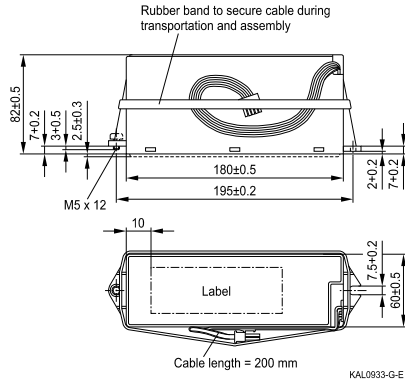

Dimensions in mm

Electrical specifications

Rated capacitance	($T_A = 25\text{ °C}$; DCC) ¹⁾	C_R	9	F
Tolerance of C_R			-10/+30	%
Rated voltage	($T_A = 25\text{ °C}$)	V_R	28	V
Capacity			70	mAh
Specific power	(IEC 62391-2)		1.0	kW/kg
Specific power	(IEC 62391-2)		0.9	kW/l
Stored energy	($V = V_R$)	E	3528	J
Specific energy	($V = V_R$)		1.3	Wh/kg
Specific energy	($V = V_R$)		1.1	Wh/l
Surge voltage		V_{surge}	32	V
Maximum series resistance	($T_A = 25\text{ °C}$; 1 kHz)	ESR	60	mΩ
Maximum series resistance	($T_A = 25\text{ °C}$; 50 mHz)	ESR _{DC}	120	mΩ
Weight			0.75	kg
Volume			0.9	l
Operating temperature range		T_{op}	-30/+70	°C
Storage temperature	($V = 0\text{ V}$)	T_{st}	-40/+70	°C
Lifetime (hours) ²⁾	($T_A = 25\text{ °C}$; $V = V_R$)		90000	h
Lifetime (cycles) ³⁾	($T_A = 25\text{ °C}$; $I = 10\text{ A}$)		500000	cycles

1) DCC: discharging with constant current.

2) Requirements: $|\Delta C/C_R| \leq 30\%$, $\text{ESR} \leq 2$ times of specified limit, $I_{\text{leak}} \leq 2$ times of initial value.

3) Requirements: $|\Delta C/C_R| \leq 30\%$, $\text{ESR} \leq 2$ times of specified limit, $I_{\text{leak}} \leq 2$ times of initial value (1 cycle: charging to V_R , 30 s rest, discharging to $V_R/2$, 30 s rest).