



Chipsmall Limited consists of a professional team with an average of over 10 year of expertise in the distribution of electronic components. Based in Hongkong, we have already established firm and mutual-benefit business relationships with customers from,Europe,America and south Asia,supplying obsolete and hard-to-find components to meet their specific needs.

With the principle of “Quality Parts,Customers Priority,Honest Operation,and Considerate Service”,our business mainly focus on the distribution of electronic components. Line cards we deal with include Microchip,ALPS,ROHM,Xilinx,Pulse,ON,Everlight and Freescale. Main products comprise IC,Modules,Potentiometer,IC Socket,Relay,Connector.Our parts cover such applications as commercial,industrial, and automotives areas.

We are looking forward to setting up business relationship with you and hope to provide you with the best service and solution. Let us make a better world for our industry!



Contact us

Tel: +86-755-8981 8866 Fax: +86-755-8427 6832

Email & Skype: info@chipsmall.com Web: www.chipsmall.com

Address: A1208, Overseas Decoration Building, #122 Zhenhua RD., Futian, Shenzhen, China





Metal Oxide Varistor	Disc type
SIOV- S10K60S5	Ordering code: B72210S0600K501

Data sheet

Form: FBLE3K/b

File name: S10K60S5_a.doc

MODIFICATIONS: New Issue

REMARKS:

Prepared by	Collins-Hunt	Release	signed: PE / Collins-Hunt		signed: QS /		
			signed:		signed:		
ISSUE DATE	13.03.03	ISSUE	a	PUBLISHER	KH PE VAR	PAGE	0/6

Data sheet
SIOV nomenclature:

S	=	Disk type
10	=	Rated disk diameter
K	=	Tolerance of V_V at 1mA : $\pm 10\%$
60	=	Max. AC voltage
S5	=	Crimp style

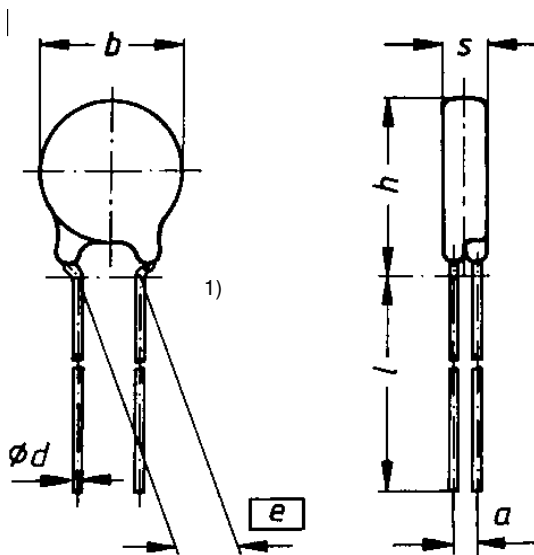
Figure: Dimensions given in Millimeters (mm)

b_{max}	=	12,0
h_{max}	=	15,5
s_{max}	=	4,0
e	=	$7,5 \pm 1,0$
a	=	$1,4 \pm 1,0$
$\varnothing d$	=	$0,8 \pm 0,05$
l	=	n.a.

¹⁾ seating plane in accordance with IEC 60717

Electrical data:
Maximum Ratings (85°C):

Max. operating AC voltage	V_{RMS}	=	60V
Max. operating DC voltage	V_{DC}	=	85V
Surge current (8/20 μ s) 1 time	I_{max}	=	2500A
Energy absorption (2ms) 1 time	W_{max}	=	10J
Average power dissipation	P_{max}	=	0,4W

Characteristics (25°C):

Varistor voltage at 1mA	V_V	=	$100V \pm 10\%$
Clamping voltage at 25A (8/20 μ s)	$V_{C,max}$	=	165V
Typ. capacitance at 1 kHz	C	=	870pF

Data sheet

V/I Characteristic:

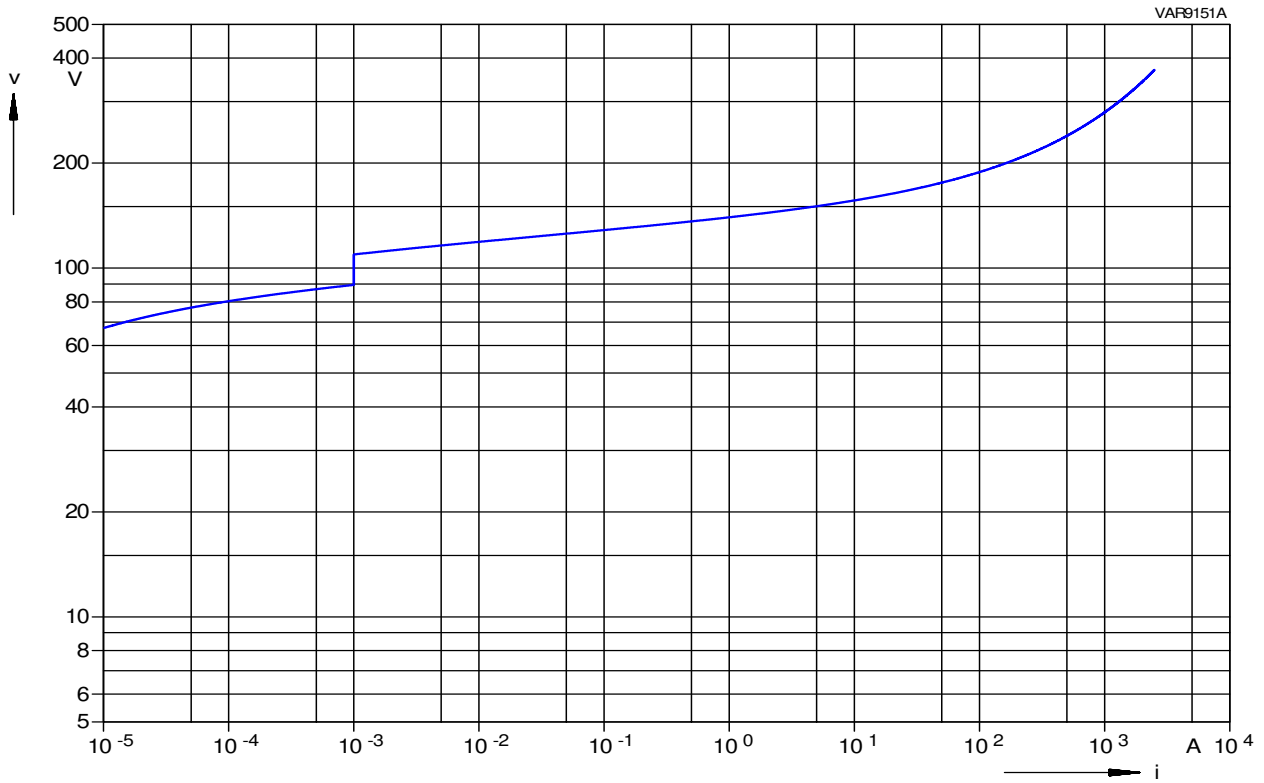

Derating:

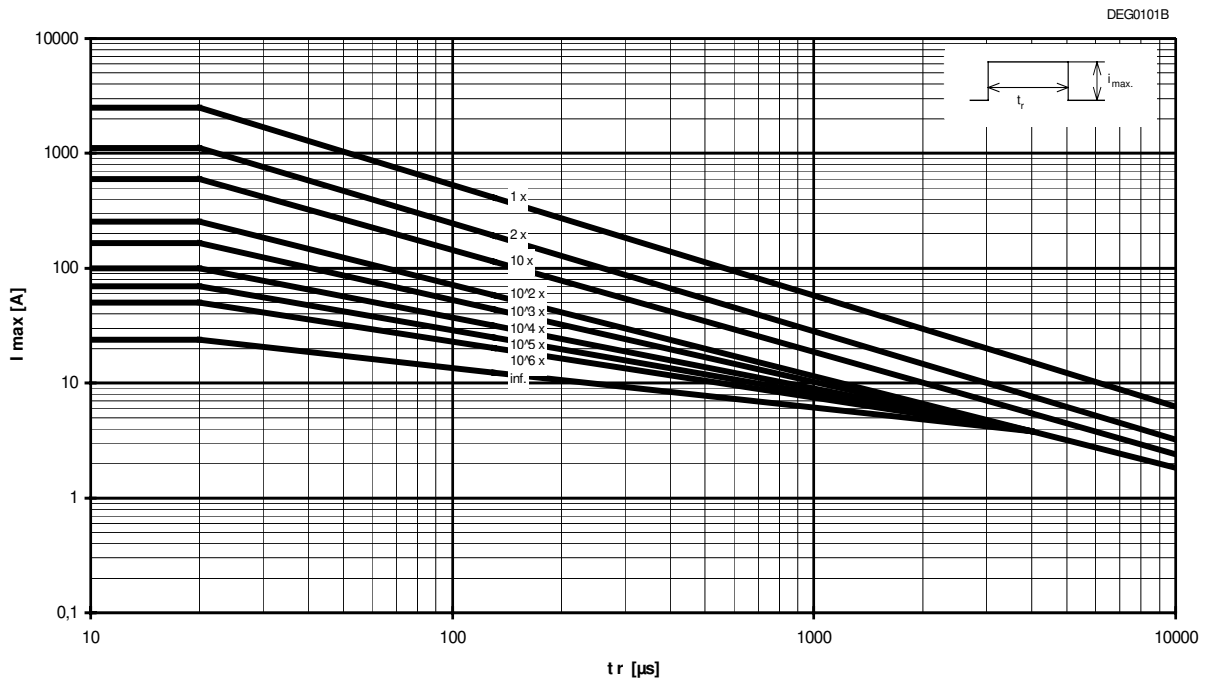

Reliability Data:

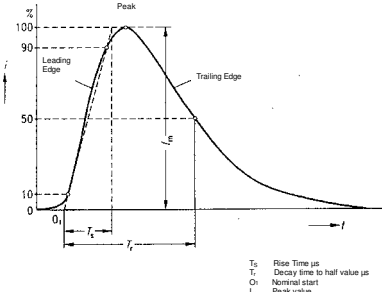
	Characteristics	Test Methods/Description	Specifications
E	Varistor Voltage	The voltage between two terminals with the specified measuring current applied is called V_V ($1 \text{ mA}_{\text{DC}} @ 0.2 - 2 \text{ s}$).	To meet the specified value.
L E C T R I C	Clamping Voltage	<p>The maximum voltage between two terminals with the specified standard impulse current ($8/20\mu\text{s}$) illustrated below applied.</p>  <p> T_1 Rise Time μs T_2 Decay time to half value μs O_1 Nominal start I_0 Peak value </p>	To meet the specified value.
A	Surge current derating, $8/20 \mu\text{s}$	100 surge currents ($8/20 \mu\text{s}$), unipolar, interval 30 s, amplitude corresponding to derating curve for $20 \mu\text{s}$	$ \Delta V/V (1 \text{ mA}) \leq 10 \%$ (measured in direction of surge current) No visible damage
L	Surge current derating, 2 ms	100 surge currents (2ms), unipolar, interval 120s, amplitude corresponding to derating curve for 2ms	$ \Delta V/V (1 \text{ mA}) \leq 10 \%$ (measured in direction of surge current) No visible damage



Data sheet

	Characteristics	Test Methods/Description	Specifications							
M	Tensile strength	After gradually applying the force specified below and keeping the unit fixed for 10 seconds, the terminal shall be visually examined for any damage.	$ \Delta V/V (1 \text{ mA}) \leq 5 \%$ No break of solder joint, no wire break							
		<table border="1"> <thead> <tr> <th>Terminal diameter</th> <th>Force</th> </tr> </thead> <tbody> <tr> <td>0.5 mm</td> <td>5 N</td> </tr> <tr> <td>0.6 mm</td> <td>10 N</td> </tr> <tr> <td>0.8 mm</td> <td>10 N</td> </tr> <tr> <td>1.0 mm</td> <td>20 N</td> </tr> </tbody> </table>		Terminal diameter	Force	0.5 mm	5 N	0.6 mm	10 N	0.8 mm
Terminal diameter	Force									
0.5 mm	5 N									
0.6 mm	10 N									
0.8 mm	10 N									
1.0 mm	20 N									
E C H	Vibration	After repeatedly applying a single harmonic vibration according to the table below. Thereafter, the unit shall be visually examined. frequency range: 10 ... 55 Hz amplitude: 0.75 mm or 98 m/s ² duration: 6 h (3 x 2 h) pulse: sine wave	$ \Delta V/V (1 \text{ mA}) \leq 5 \%$ No visible damage							
A N I C A L	Solderability	After dipping the terminals to a depth of approximately 3 mm from the body in a soldering bath of 235°C for 5 seconds, the terminals shall be visually examined.	The inspection shall be carried out under adequate light with normal eyesight or with the assistance of a magnifier capable of giving a magnification of 4 times to 10 times. The dipped surface shall be covered with a smooth and bright solder coating with no more than small amounts of scattered imperfections such as pinholes or un-wetted or de-wetted areas. These imperfections shall not be concentrated in one area.							



Data sheet

	Characteristics	Test Methods/Description	Specifications
M E C H A N I C A L	Resistance to soldering heat	Each lead shall be dipped into a solder bath having a temperature of $260 \pm 5^{\circ}\text{C}$ to a point 2.0 to 2.5 mm from the body of the unit, be held there for 10 ± 1 s and then be stored at room temperature and normal humidity for 1 to 2 hours. The change of V_v and mechanical damages shall be examined.	$ \Delta V/V (1 \text{ mA}) \leq 5 \%$ No visible damage
	Electric strength	2500 V_{RMS} , 10 s The varistor is placed in a container holding 1.6 \pm 0.2 mm diameter metal balls such that only the terminations of the varistor are protruding. The specified voltage shall be applied between both terminals of the specimen connected together and the electrode inserted between the metal balls.	No breakdown



Data sheet

	Characteristics	Test Methods/Description	Specifications												
E N V I	Max. AC operating voltage	After being continuously applied the maximum allowable voltage at $85 \pm 2^\circ\text{C}$ for 1000 hours, the specimen shall be stored at room temperature and normal humidity for 1 to 2 hours. Thereafter, the change of V_v shall be measured.	$ \Delta V/V (1 \text{ mA}) \leq 10 \%$												
	Damp heat, steady state	The specimen shall be subjected to $40 \pm 2^\circ\text{C}$, 90 to 95 % r.H. for 56 days without load and then stored at room temperature and normal humidity for 1 to 2 hours. Thereafter, the change of V_v shall be measured.	$ \Delta V/V (1 \text{ mA}) \leq 10 \%$												
R O N M	Climatic sequence	The specimen shall be subjected to: a) dry heat at $+85^\circ\text{C}$, 16 h b) damp heat, 1st cycle: 55°C , 93 % r.H., 24 h c) cold, -40°C , 2 h d) damp heat, additional 5 cycles: 55°C , 93 % r.H., 24 h/cycle Then the specimen shall be stored at room temperature and normal humidity for 1 to 2 hours. Thereafter, the change of V_v shall be measured.	$ \Delta V/V (1 \text{ mA}) \leq 10 \%$												
E N T A L	Fast temperature cycling	The temperature cycle shown below shall be repeated 5 times. Then the specimen shall be stored at room temperature and normal humidity for 1 to 2 hours. The change of V_v and mechanical damage shall be examined. <table border="1" style="margin-left: auto; margin-right: auto;"> <thead> <tr> <th>Step</th> <th>Temperature ($^\circ\text{C}$)</th> <th>Period (min.)</th> </tr> </thead> <tbody> <tr> <td>1</td> <td>-40 ± 3</td> <td>30 ± 3</td> </tr> <tr> <td>2</td> <td>transition time</td> <td>$< 10 \text{ s}$</td> </tr> <tr> <td>3</td> <td>85 ± 2</td> <td>30 ± 3</td> </tr> </tbody> </table>	Step	Temperature ($^\circ\text{C}$)	Period (min.)	1	-40 ± 3	30 ± 3	2	transition time	$< 10 \text{ s}$	3	85 ± 2	30 ± 3	$ \Delta V/V (1 \text{ mA}) \leq 5 \%$ No visible damage
Step	Temperature ($^\circ\text{C}$)	Period (min.)													
1	-40 ± 3	30 ± 3													
2	transition time	$< 10 \text{ s}$													
3	85 ± 2	30 ± 3													

Note: More details can be found in the data book 'SIOV Metal Oxide Varistors', Ordering No. EPC: 62002-7600

© EPCOS AG 2002. Reproduction, publication and dissemination of this data sheet, enclosures hereto and the information contained therein without EPCOS' prior express consent is prohibited.

Purchase orders are subject to the General Conditions for the Supply of Products and Services of the Electrical and Electronics Industry recommended by the ZVEI (German Electrical and Electronic Manufacturers' Association), unless otherwise agreed.

ISSUE DATE	13.03.03	ISSUE	a	PUBLISHER	KH PE VAR	PAGE	6/6
------------	----------	-------	---	-----------	-----------	------	-----