



Chipsmall Limited consists of a professional team with an average of over 10 year of expertise in the distribution of electronic components. Based in Hongkong, we have already established firm and mutual-benefit business relationships with customers from,Europe,America and south Asia,supplying obsolete and hard-to-find components to meet their specific needs.

With the principle of “Quality Parts,Customers Priority,Honest Operation,and Considerate Service”,our business mainly focus on the distribution of electronic components. Line cards we deal with include Microchip,ALPS,ROHM,Xilinx,Pulse,ON,Everlight and Freescale. Main products comprise IC,Modules,Potentiometer,IC Socket,Relay,Connector.Our parts cover such applications as commercial,industrial, and automotives areas.

We are looking forward to setting up business relationship with you and hope to provide you with the best service and solution. Let us make a better world for our industry!



## Contact us

Tel: +86-755-8981 8866 Fax: +86-755-8427 6832

Email & Skype: info@chipsmall.com Web: www.chipsmall.com

Address: A1208, Overseas Decoration Building, #122 Zhenhua RD., Futian, Shenzhen, China



**Feedthrough Filter B85321A4205B630**

**FEATURES:**

Metallized (selfhealing) film capacitors. High insertion loss up to the GHz range. Metal case, resin sealed, plastic insulating bush (UL94-V0).

**RATINGS AND CHARACTERISTICS:**

Rated Capacitance	2 x 1 $\mu$ F
Capacitance Tolerance	$\pm$ 20%
Rated Voltage	440VAC / 600VDC
Subclass (EN133200)	X2
Rated Current (T <sub>amb</sub> -55°C)	63A
Test Voltage (Terminal-Case)	2500VDC / 2s
Climatic Category	40/085/56
Approx.Weight	600g
Mounting Thread	M32 x 1,5
Terminal Thread	M6

**TYPICAL INSERTION LOSS (50 $\Omega$ ):**

f	10 KHz	100 KHz	1 MHz	10 MHz	100 MHz	1 GHz
dB	12	30	60	>100	>100	>100

Circuit Diagram:



**MATERIAL:**

Metal case, nickel plated. UL-listed material for resin and plastic insulating bush. Terminals, nuts and washers are nickel- or tin plated.

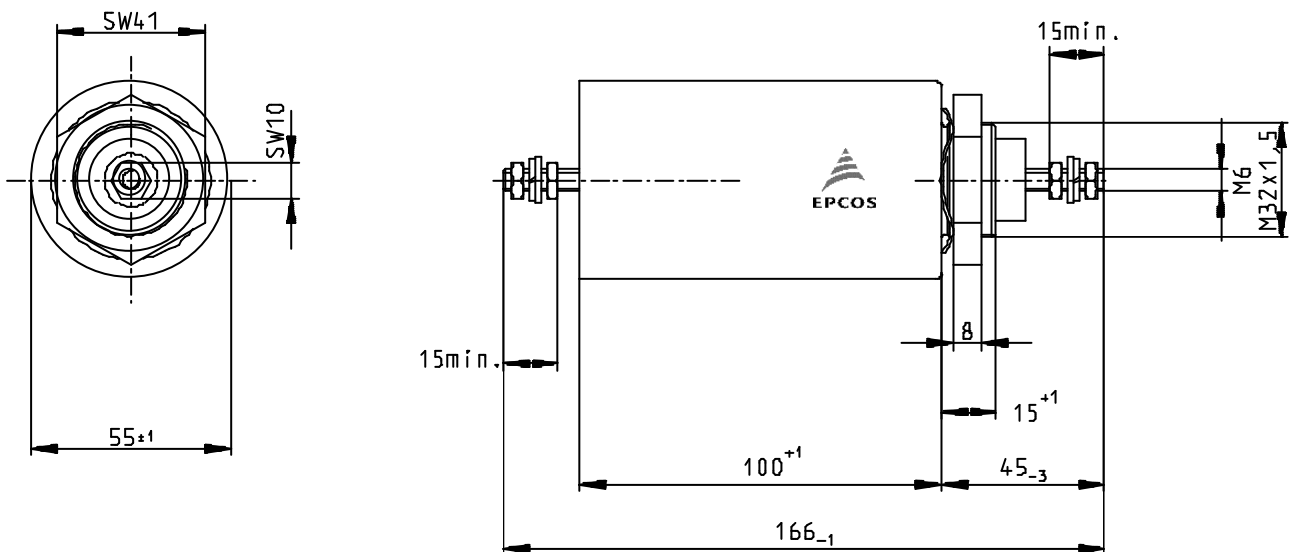

**Published by EPCOS AG**  
**Corporate Communications, P.O. Box 80 17 09, 81617 Munich, GERMANY**  
**☎ ++49 89 636 09, FAX (0 89) 636-2 26 89**

© EPCOS AG 2002. Reproduction, publication and dissemination of this brochure and the information contained therein without EPCOS' prior express consent is prohibited.

Purchase orders are subject to the General Conditions for the Supply of Products and Services of the Electrical and Electronics Industry recommended by the ZVEI (German Electrical and Electronic Manufacturers' Association), unless otherwise agreed.

This brochure replaces the previous edition.

For questions on technology, prices and delivery please contact the Sales Offices of EPCOS AG or the international Representatives.

Due to technical requirements components may contain dangerous substances. For information on the type in question please also contact one of our Sales Offices.