



Chipsmall Limited consists of a professional team with an average of over 10 year of expertise in the distribution of electronic components. Based in Hongkong, we have already established firm and mutual-benefit business relationships with customers from,Europe,America and south Asia,supplying obsolete and hard-to-find components to meet their specific needs.

With the principle of “Quality Parts,Customers Priority,Honest Operation,and Considerate Service”,our business mainly focus on the distribution of electronic components. Line cards we deal with include Microchip,ALPS,ROHM,Xilinx,Pulse,ON,Everlight and Freescale. Main products comprise IC,Modules,Potentiometer,IC Socket,Relay,Connector.Our parts cover such applications as commercial,industrial, and automotives areas.

We are looking forward to setting up business relationship with you and hope to provide you with the best service and solution. Let us make a better world for our industry!



Contact us

Tel: +86-755-8981 8866 Fax: +86-755-8427 6832

Email & Skype: info@chipsmall.com Web: www.chipsmall.com

Address: A1208, Overseas Decoration Building, #122 Zhenhua RD., Futian, Shenzhen, China





Switching spark gap

SSG with lead wires

Series/Type: FS04X-1JMG
Ordering code: B88069X0410T502
Version/Date: Issue 06 / 2009-06-29

© EPCOS AG 2015. Reproduction, publication and dissemination of this publication, enclosures hereto and the information contained therein without EPCOS' prior express consent is prohibited.

EPCOS AG is a TDK Group Company.

Features	Applications
<ul style="list-style-type: none"> ▪ Extremely long life time ▪ Stable performance over life ▪ Insensitive performance against variations in temperature ▪ Extremely low switching losses ▪ Very short breakdown time ▪ High reliability by robust design ▪ RoHS compatible 	<ul style="list-style-type: none"> ▪ Ignition of HID lamps

Electrical specifications

Nominal breakdown voltage V_N	400	V
Initial values		
Static breakdown voltage V_S ^{1) 2)}		
First ignition value $V_{S, FTE}$ after 24 hours in darkness	≤ 460	V
Following ignition values (selection limits)	360 ... 420	V
Following ignition values $V_{S, FIV}$	350 ... 430	V
Breakdown voltage V_B (measuring time 200 ms) ⁴⁾		
First ignition value $V_{B, FTE}$	≤ 460	V
Following ignition values $V_{B, FIV}$	340 ... 460	V
Electrical life time ³⁾		
Breakdown voltage V_B		
First ignition value $V_{B, FTE}$ initial after 24 hours in darkness	≤ 460	V
First ignition value $V_{B, FTE}$ after 24 hours in darkness	≤ 500	V
Following ignition values $V_{B, FIV}$	340 ... 460	V
Switching operations		
at - 40 °C Ignition time t_i ≤ 60 ms ⁵⁾	60 000	Ignitions
at - 40 °C Ignition time t_i ≤ 200 ms	100 000	Ignitions
at +25 °C Ignition time t_i ≤ 60 ms	100 000	Ignitions
at +25 °C Ignition time t_i ≤ 200 ms	200 000	Ignitions
at +125 °C Ignition time t_i ≤ 60 ms	200 000	Ignitions
Test circuit parameters		
Open circuit voltage V_0	500	V
Loading resistance R	10	kΩ
Discharge capacitance C	680	nF
Inductance L	0.5	μH
Discharge peak current I_P	~ 500	A

General technical data Insulation resistance at 100 V Early ignition values below 340 V Breakdown time Maximum switching frequency Maximum loading current Weight	> 100 ≤ 2 ≤ 50 200 50 ~ 2	$M\Omega$ % ns Hz mA g
Marking, blue positive	EPCOS 400 WWY O 400 - Nominal voltage WW - Calendar week of production Y - Year of production O - Non radioactive	

- 1) At delivery AQL 0,65 level II, DIN ISO 2859
- 2) Page 2, Fig. 1 and 2
- 3) Page 2, Fig. 3 and 4
- 4) Page 2, Fig. 3 and 4, 100 % outgoing inspection
- 5) After storage in darkness for 30 days

Figures

Fig. 1: QC- test circuit (100% outgoing inspection)

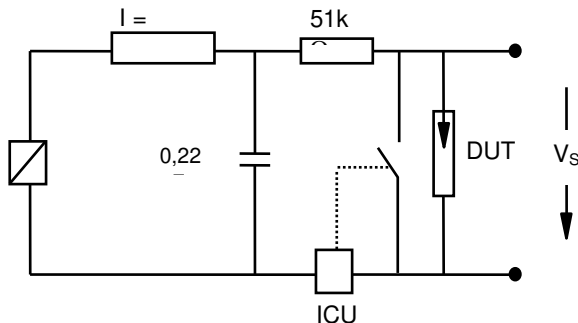

DUT device under test
 ICU ignition control unit (sensitivity 10...30 μA)
 Discharge current 10...20 mA

Fig. 2: Explanation of measurands

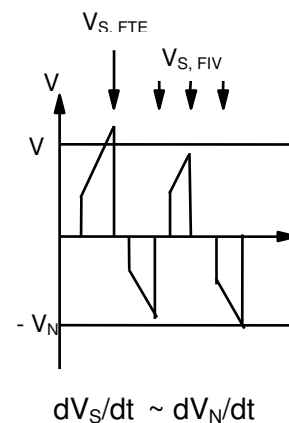

Fig. 3: QC- test circuit (sampling inspection at 25

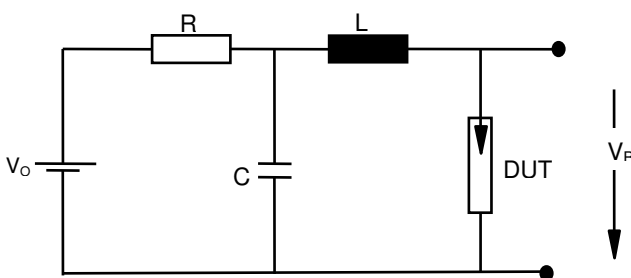
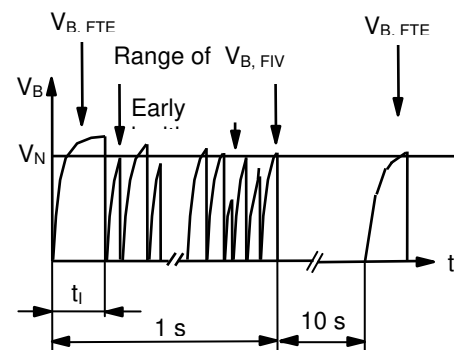
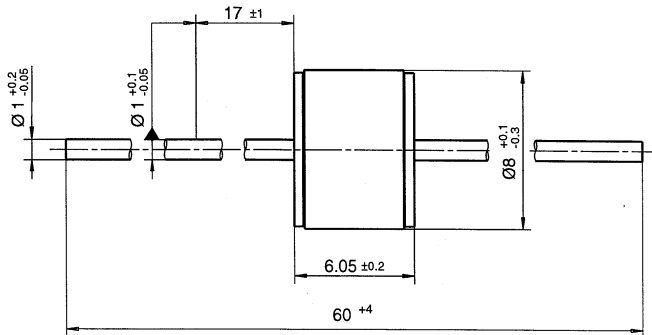

Fig. 4: Explanation of measurands



Dimensional drawing

Not to scale

Dimensions in mm

Non controlled document

Packing advice

T502 = 500 pcs on tape and reel

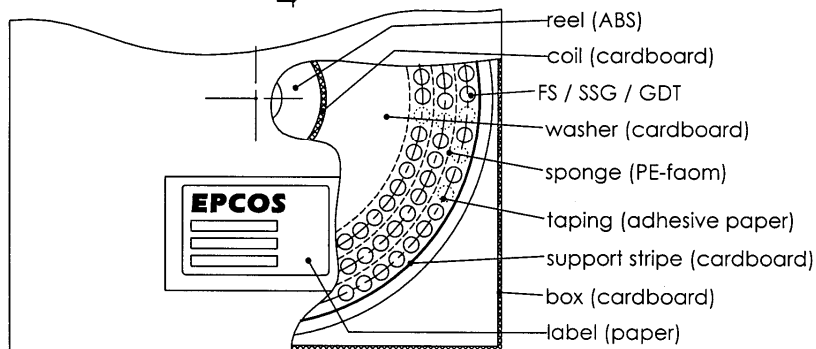
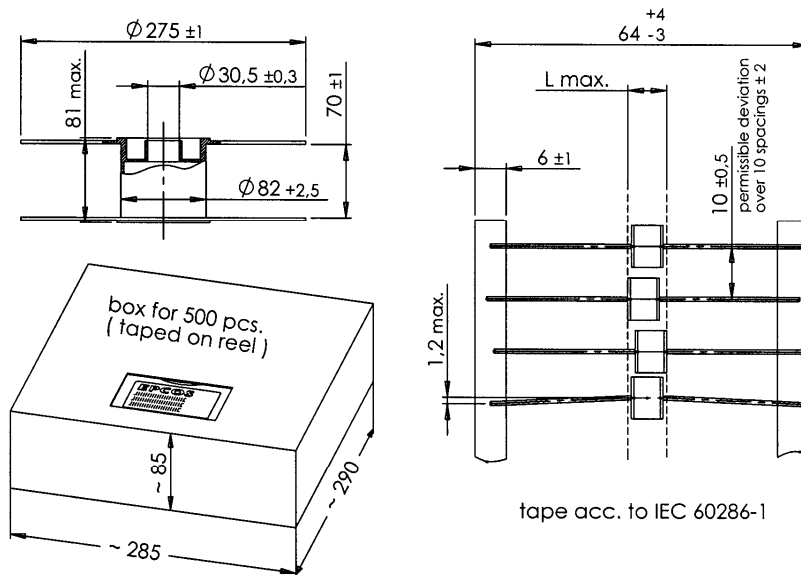
Cautions and warnings

- Switching spark gaps may be used only within their specified values.
- Damaged switching spark gaps must not be re-used.

Important notes

The following applies to all products named in this publication:

1. Some parts of this publication contain **statements about the suitability of our products for certain areas of application**. These statements are based on our knowledge of typical requirements that are often placed on our products in the areas of application concerned. We nevertheless expressly point out **that such statements cannot be regarded as binding statements about the suitability of our products for a particular customer application**. As a rule, EPCOS is either unfamiliar with individual customer applications or less familiar with them than the customers themselves. For these reasons, it is always ultimately incumbent on the customer to check and decide whether an EPCOS product with the properties described in the product specification is suitable for use in a particular customer application.
2. We also point out that **in individual cases, a malfunction of electronic components or failure before the end of their usual service life cannot be completely ruled out in the current state of the art, even if they are operated as specified**. In customer applications requiring a very high level of operational safety and especially in customer applications in which the malfunction or failure of an electronic component could endanger human life or health (e.g. in accident prevention or life-saving systems), it must therefore be ensured by means of suitable design of the customer application or other action taken by the customer (e.g. installation of protective circuitry or redundancy) that no injury or damage is sustained by third parties in the event of malfunction or failure of an electronic component.
3. **The warnings, cautions and product-specific notes must be observed.**
4. In order to satisfy certain technical requirements, **some of the products described in this publication may contain substances subject to restrictions in certain jurisdictions (e.g. because they are classed as hazardous)**. Useful information on this will be found in our Material Data Sheets on the Internet (www.epcos.com/material). Should you have any more detailed questions, please contact our sales offices.
5. We constantly strive to improve our products. Consequently, **the products described in this publication may change from time to time**. The same is true of the corresponding product specifications. Please check therefore to what extent product descriptions and specifications contained in this publication are still applicable before or when you place an order. We also **reserve the right to discontinue production and delivery of products**. Consequently, we cannot guarantee that all products named in this publication will always be available. The aforementioned does not apply in the case of individual agreements deviating from the foregoing for customer-specific products.
6. Unless otherwise agreed in individual contracts, **all orders are subject to the current version of the "General Terms of Delivery for Products and Services in the Electrical Industry" published by the German Electrical and Electronics Industry Association (ZVEI)**.
7. The trade names EPCOS, BAOKE, Alu-X, CeraDiode, CSMP, CSSP, CTVS, DSSP, MiniBlue, MKK, MLSC, MotorCap, PCC, PhaseCap, PhaseCube, PhaseMod, SIFERRIT, SIFI, SIKOREL, SilverCap, SIMDAD, SIMID, SineFormer, SIOV, SIP5D, SIP5K, ThermoFuse, WindCap are **trademarks registered or pending** in Europe and in other countries. Further information will be found on the Internet at www.epcos.com/trademarks.