



Chipsmall Limited consists of a professional team with an average of over 10 year of expertise in the distribution of electronic components. Based in Hongkong, we have already established firm and mutual-benefit business relationships with customers from,Europe,America and south Asia,supplying obsolete and hard-to-find components to meet their specific needs.

With the principle of "Quality Parts,Customers Priority,Honest Operation,and Considerate Service",our business mainly focus on the distribution of electronic components. Line cards we deal with include Microchip,ALPS,ROHM,Xilinx,Pulse,ON,Everlight and Freescale. Main products comprise IC,Modules,Potentiometer,IC Socket,Relay,Connector.Our parts cover such applications as commercial,industrial, and automotives areas.

We are looking forward to setting up business relationship with you and hope to provide you with the best service and solution. Let us make a better world for our industry!



## Contact us

Tel: +86-755-8981 8866 Fax: +86-755-8427 6832

Email & Skype: info@chipsmall.com Web: www.chipsmall.com

Address: A1208, Overseas Decoration Building, #122 Zhenhua RD., Futian, Shenzhen, China



# Reversible motor driver

## BA6285FS / BA6285FP

The BA6285FS and BA6285FP are reversible-motor drivers with a maximum output current of 1.0A. Two logic inputs allow four output modes: forward, reverse, stop (idling), and brake. A built-in power saving circuit suppresses current consumption when the motor is in stop mode.

### ●Applications

VCRs and audio equipment in general

### ●Features

- 1) Logic and power sections have separate ground pins; this allows the IC to drive speed-variable, reversible motors by connecting an electronic governor circuit.
- 2) Built-in power saving circuit suppresses the stop mode current dissipation.
- 3) Output voltage can be set arbitrarily with the  $V_{ref}$  pin.
- 4) Interfaces with TTL devices.
- 5) Built-in thermal shutdown circuit.

### ●Absolute maximum ratings ( $T_a = 25^\circ\text{C}$ )

Parameter		Symbol	Limits	Unit
Power supply voltage		$V_{CC}$	18	V
Power dissipation	BA6285FS	$P_d$	800*1	mW
	BA6285FP		1500*2	
Operating temperature		$T_{opr}$	$-20 \sim +75$	$^\circ\text{C}$
Storage temperature		$T_{stg}$	$-55 \sim +150$	$^\circ\text{C}$
Output current		$I_{Omax}$	1000*3	mA

Note: When mounted on a glass epoxy PCB (90 × 50 × 1.6 mm).

\*1 Reduced by 6.4 mW for each increase in  $T_a$  of  $1^\circ\text{C}$  over  $25^\circ\text{C}$ .

\*2 Reduced by 12.0 mW for each increase in  $T_a$  of  $1^\circ\text{C}$  over  $25^\circ\text{C}$ .

\*3 Should not exceed  $P_d$  or ASO values.

### ●Recommended operating conditions ( $T_a = 25^\circ\text{C}$ )

Parameter	Symbol	Min.	Typ.	Max.	Unit
Operating power supply voltage	$V_{CC}$	4.5	—	15	V
	$V_M$	4.5	—	15	V
	$V_{REF}$	4.5	—	15	V

● Block diagram

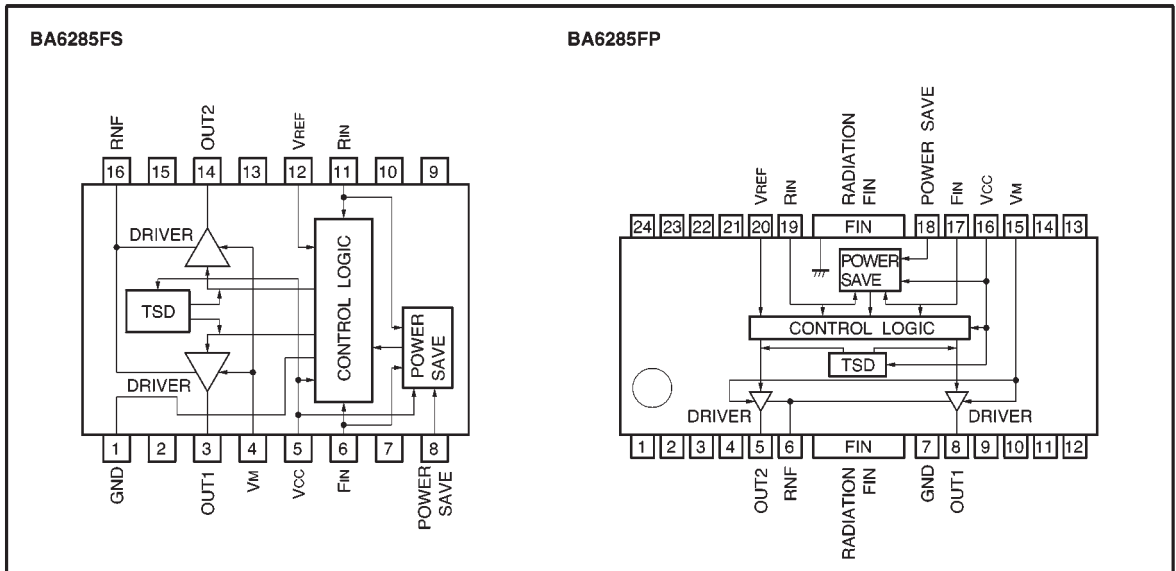

● Pin descriptions

BA6285FS

Pin No.	Pin name	Function
1	GND	GND
2	N.C.	—
3	OUT1	Motor output
4	VM	Motor power supply
5	VCC	Power supply
6	FIN	Logic input
7	N.C.	—
8	POWER SAVE	Power save switch; operating mode when 0.8 V or less, standby mode when 2.0 V or more
9	N.C.	—
10	N.C.	—
11	RIN	Logic input
12	VREF	HIGH level output voltage setting
13	N.C.	—
14	OUT2	Motor output
15	N.C.	—
16	RNF	Output section ground pin; resistor connection pin for detecting output current

## BA6285FP

Pin No.	Pin name	Function
1	N.C.	—
2	N.C.	—
3	N.C.	—
4	N.C.	—
5	OUT2	Motor output
6	RNF	Output section ground ; resistor connection for detecting output current
7	GND	GND
8	OUT1	Motor output
9	N.C.	—
10	N.C.	—
11	N.C.	—
12	N.C.	—
13	N.C.	—
14	N.C.	—
15	V <sub>M</sub>	Motor power supply
16	V <sub>CC</sub>	Power supply
17	F <sub>IN</sub>	Logic input
18	POWER SAVE	Power save switch; operating mode when 0.8 V or less, standby mode when 2.0 V or more
19	R <sub>IN</sub>	Logic input
20	V <sub>REF</sub>	HIGH level output voltage setting
21	N.C.	—
22	N.C.	—
23	N.C.	—
24	N.C.	—
FIN	FIN	Note: make sure to connect the radiation FINS to GND

● Input / output circuits

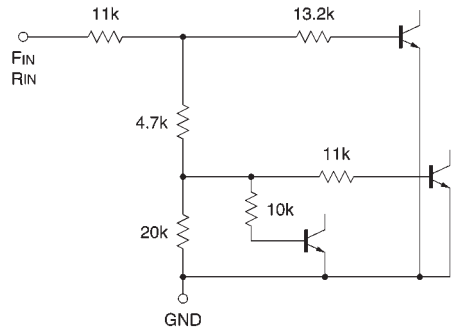
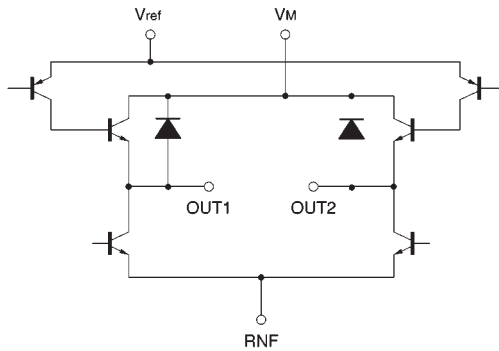

● Electrical characteristics (unless otherwise noted,  $T_a = 25^\circ$ ,  $V_{CC} = 9V$ ,  $V_M = 9V$ ,  $V_{REF} = 9V$ )

Parameter	Symbol	Min.	Typ.	Max.	Unit	Conditions	Measurement circuit
Supply current 1	$I_{CC1}$	12	24	36	mA	Forward or reverse mode	Fig.1,5
Supply current 2	$I_{CC2}$	29	48	67	mA	Brake mode	Fig.1,5
Standby supply current	$I_{ST}$	—	—	15	$\mu A$	Standby mode	Fig.1,5
$V_{REF}$ pin sink current	$I_{REF}$	6	12	18	mA	Forward or reverse mode $I_o = 200mA$	Fig.1,5
Input high level voltage	$V_{IH}$	2.0	—	—	V	—	Fig.2,6
Input low level voltage	$V_{IL}$	—	—	0.8	V	—	Fig.2,6
Input high level current	$I_{IH}$	45	90	135	$\mu A$	$V_{IN} = 2.0V$	Fig.2,6
Output saturation voltage	$V_{CE}$	—	1.0	1.5	V	$I_o = 200mA$ Sum of output transistor high- and low-side voltages	Fig.3,7
Power save mode OFF voltage	$V_{PS OFF}$	—	—	0.8	V	Operating mode	Fig.4,8
Power save mode ON voltage	$V_{PS ON}$	2.0	—	—	V	Standby mode	Fig.4,8

● Measurement circuits

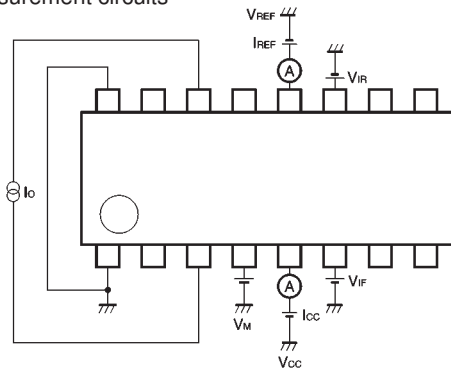

\* Refer to the truth table for output mode. The supply current is represented by the  $I_{CC}$ -value, and the  $V_{ref}$  sink current is represented by the  $I_{REF}$ -value. The direction of the  $I_O$  current is from the HIGH level to the LOW level output pin.

Fig.1

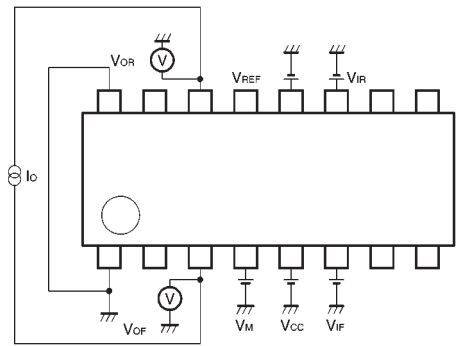

$V_{CE}$  is the sum of the high- and low-side output transistor C-E voltages. The direction of the  $I_O$  current is from the HIGH level to the LOW level output pin.

Fig.3

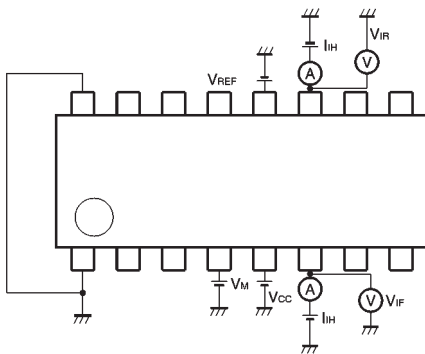

\* Refer to the truth table for output mode. HIGH and LOW level input voltages correspond to the readings of  $V_{IF}$  and  $V_{IR}$  voltmeters, respectively. The HIGH level input current is represented by the  $I_H$  ammeter reading when  $V_{IN} = 2\text{ V}$ .

Fig.2

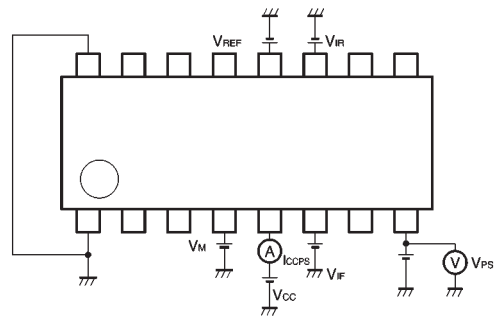

The power save mode ON voltage is represented by the  $V_{PS}$  reading when  $I_{CCPS}$  is  $15\ \mu\text{A}$  or less. The power save mode OFF voltage is represented by the  $V_{PS}$  reading when  $I_{CCPS}$  is more than  $15\ \mu\text{A}$ .

Fig.4

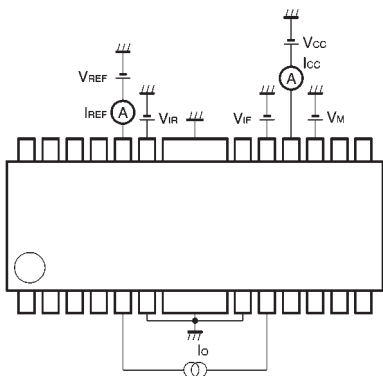

\* Refer to the truth table for output mode. The supply current is represented by the ICC-value, and the VREF sink current is represented by the IREF-value. The direction of the Io current is from the HIGH level to the LOW level output pin.

Fig.5

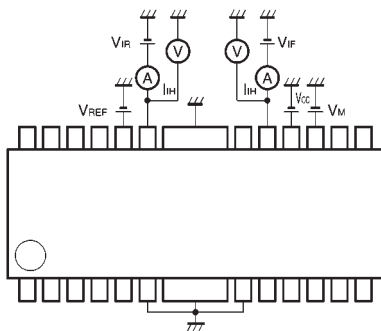

\* Refer to the truth table for output mode. HIGH and LOW level input voltages correspond to the readings of VIF and VIR voltmeters, respectively. The HIGH level input current is represented by the VIH ammeter reading when VIN = 2 V.

Fig.6

● Circuit operation

(1) Input section

The four output modes are controlled by two logic inputs. Current flows from OUT1 to OUT2 when FIN is HIGH and RIN is LOW, and from OUT2 to OUT1 when RIN is HIGH and FIN is LOW (refer to the truth table). The input circuit can be operated by a logic circuit with a current capacity of 120 ~ 170μA.

(2) Output section

Current flows from OUT1 to OUT2 during forward rotation, and from OUT2 to OUT1 during reverse rotation.

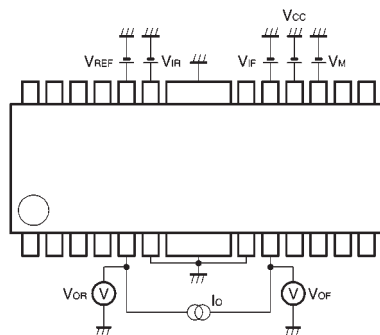

VCE is the sum of the high- and low-side output transistor C-E voltages. The direction of the Io current is from the HIGH level to the LOW level output pin.

Fig.7

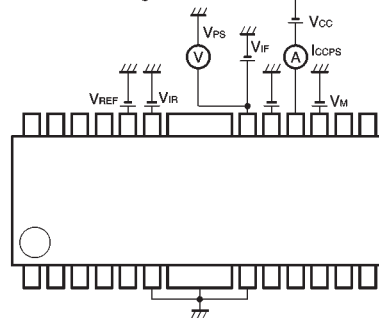

The power save mode ON voltage is represented by the VPS reading when ICCPS is 15 μA or less. The power save mode OFF voltage is represented by the VPS reading when ICCPS is more than 15 μA.

Fig.8

The output voltages VOH and VOL are given by :

$$V_{OH} [V] = V_{REF} - V_{CE(sat)} (PNP) - V_{BE} (NPN)$$

$$V_{OL} [V] = V_{CE(sat)} (NPN)$$

VCE and VBE are functions of the output current (see electrical characteristic curves). The output current can be set with the VREF pin.

(3) Power saving circuit

All circuits are turned OFF when the FIN and RIN input pins are both LOW or the POWER SAVE pin is HIGH. This circuit saves power during standby mode by leaving the outputs OPEN.

(4) Thermal shutdown circuit

When the thermal shutdown circuit is activated at the chip temperature of about 175°C (typical), the outputs are left OPEN. The temperature difference between the activation and deactivation settings is about 15°C. When the thermal shutdown circuit is deactivated, the outputs revert to the status determined by input mode.

●Application examples

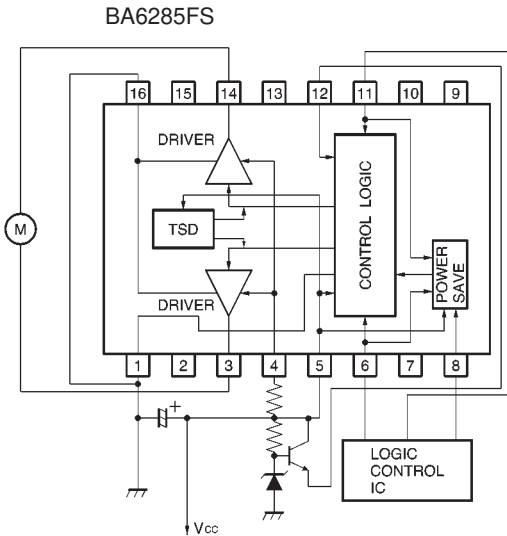

Fig.9

●Input / output truth table

F <sub>IN</sub>	R <sub>IN</sub>	OUT2	OUT1	Mode
H	L	L	H	Forward
L	H	H	L	Reverse
H	H	L	L	Brake
L	L	OPEN	OPEN	Standby

BA6285FP

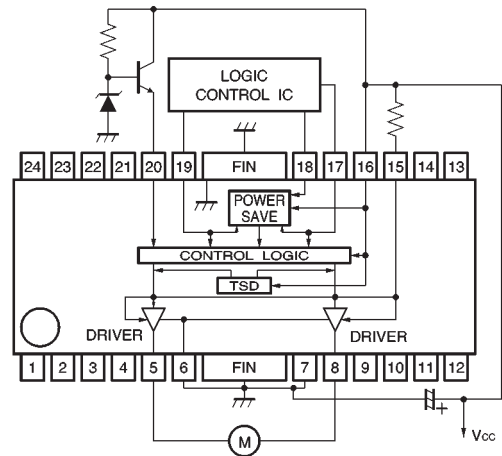

Fig.10

●Operation notes

(1) The quality of these products have been carefully checked; however, use of the products with applied voltages, operating temperatures, or other parameters that exceed the absolute maximum rating given may result in the damage of the IC and the product it is used in. If the IC is damaged, the short mode and open modes cannot be specified, so if the IC is to be used in applications where parameters may exceed the absolute maximum ratings, then be sure to incorporate fuses, or other physical safety measures.

(2) GND potential

The potential for pin 1 must be kept lower than the potentials of the other pins regardless of the circumstances.

(3) Input pins

Voltage should never be applied to the input pins when the V<sub>CC</sub> voltage is not applied to the IC. Similarly, when V<sub>CC</sub> is applied, the voltage on each input pin should be less than V<sub>CC</sub> and within the guaranteed range for the electrical characteristics.

(4) Back-rush voltage

Depending on the ambient conditions, environment, or motor characteristics, the back-rush voltage may fluctuate. Be sure to confirm that the back-rush voltage will not adversely affect the operation of the IC.



(5) Large current line

Large currents are carried by the motor power supply and motor ground for these ICs.

Therefore, the layout of the pattern of the PC board and the constants of certain parameters for external components, such as the capacitor between the power supply and ground, may cause this large output current to flow back to the input pins, resulting in output oscillation or other malfunctions. To prevent this, make sure that the PC board layout and external circuit constants cause no problems with the characteristics of these ICs.

(6) Power dissipation

The power dissipation will fluctuate depending on the mounting conditions of the IC and the ambient environment. Make sure to carefully check the thermal design of the application where these ICs will be used.

(7) Power consumption

The power consumption by the IC varies widely with the power supply voltage and the output current. Give full consideration to the power dissipation rating and the thermal resistance data and transient thermal resistance data, to provide a thermal design so that none of the ratings for the IC are exceeded.

(8) ASO

Make sure that the output current and supply voltage do not exceed the ASO values.

(9) Precautions for input mode switching

To ensure reliability, it is recommended that the mode switching for the motor pass once through the open mode.

(10) In-rush current

There are no circuits built into these ICs that prevent in-rush currents. Therefore, it is recommended to place a current limiting resistor or other physical countermeasure.

(11) Factors regarding the thermal, power supply, and motor conditions

If the potential of the output pin sways greatly and goes below the potential of ground, the operation of the IC may malfunction or be adversely affected. In such a case, place a diode between the output and ground, or other measure, to prevent this.

(12) HIGH level output voltage setting pin

Ensure that the voltage applied to the  $V_{REF}$  pin does not exceed the voltage on the motor power supply pin or the  $V_{CC}$  pin.

(13) The input and POWER SAVE pins have temperature-dependent characteristics. Take the temperature effect into consideration when using the IC.

(14) To eliminate motor noise, connect a capacitor between OUT1 and GND and between OUT2 and GND. Alternatively, connect a capacitor between OUT1 and OUT2, and also a diode between OUT1 and GND and between OUT2 and GND (see Fig. 11).

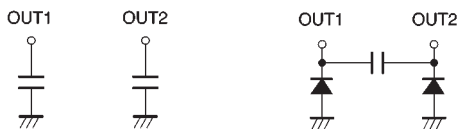

Fig.11

● Electrical characteristic curves

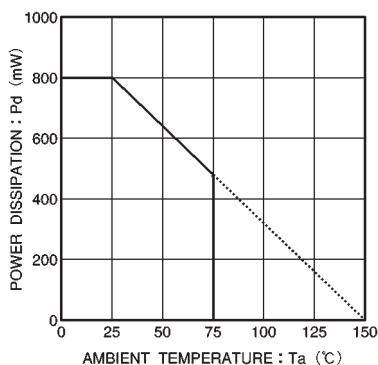

Fig.12 Temperature dependence of power dissipation curve (BA6285FS)

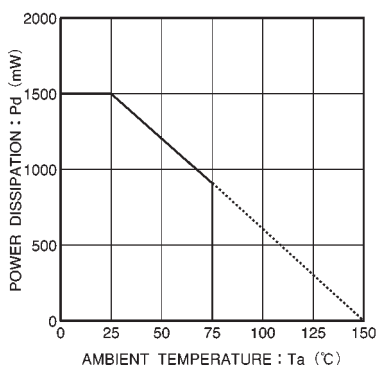

Fig.13 Temperature dependence of power dissipation curve (BA6285FP)

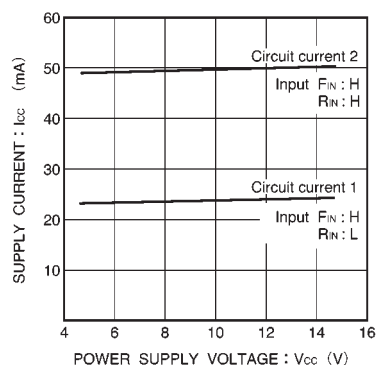

Fig.14 Supply current vs. power supply voltage

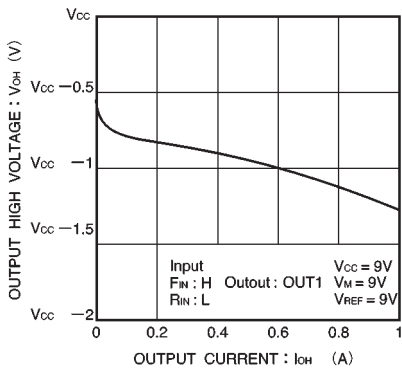

Fig.15 Output high level voltage vs. output current

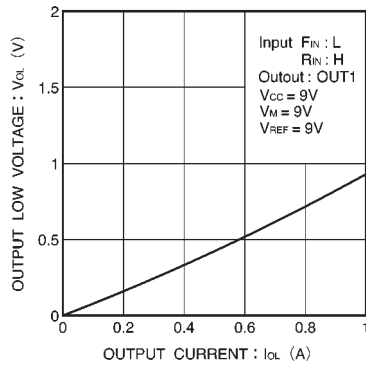

Fig.16 Output low level voltage vs. output current

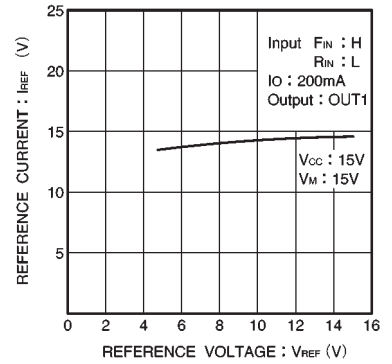

Fig.17  $V_{REF}$  reference current vs.  $V_{REF}$  reference voltage

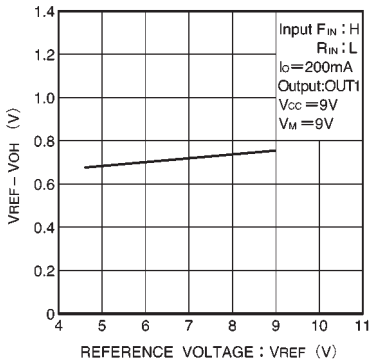

Fig.18  $V_{REF} - V_{OH}$  voltage vs.  $V_{REF}$  reference voltage

● External dimensions (Units: mm)

