



Chipsmall Limited consists of a professional team with an average of over 10 year of expertise in the distribution of electronic components. Based in Hongkong, we have already established firm and mutual-benefit business relationships with customers from,Europe,America and south Asia,supplying obsolete and hard-to-find components to meet their specific needs.

With the principle of “Quality Parts,Customers Priority,Honest Operation,and Considerate Service”,our business mainly focus on the distribution of electronic components. Line cards we deal with include Microchip,ALPS,ROHM,Xilinx,Pulse,ON,Everlight and Freescale. Main products comprise IC,Modules,Potentiometer,IC Socket,Relay,Connector.Our parts cover such applications as commercial,industrial, and automotives areas.

We are looking forward to setting up business relationship with you and hope to provide you with the best service and solution. Let us make a better world for our industry!



Contact us

Tel: +86-755-8981 8866 Fax: +86-755-8427 6832

Email & Skype: info@chipsmall.com Web: www.chipsmall.com

Address: A1208, Overseas Decoration Building, #122 Zhenhua RD., Futian, Shenzhen, China



LED level meter driver, 12-point, VU scale, dot or bar display

BA682A

The BA682A is a monolithic IC for LED level meter applications.

The display level range is 13mV_{rms} to $327\text{mV}_{\text{rms}}$ (Typ.), the 0dB level is $130\text{mV}_{\text{rms}}$ (Typ.) and the VU display is -20dB to +8dB.

The constant current outputs can be set using external components allowing use of different color LEDs in various combinations.

●Applications

Level meters for all types of audio equipment applications

●Features

- 1) 12-point VU display meter driver for bar / dot displays.
- 2) Fixed-current outputs that can directly drive LEDs.
- 3) Output current can be set using external resistors allowing different types of LEDs to be used in combination.
- 4) Built-in half-wave rectifier amplifier.
- 5) LED on and off timing can be set using an external capacitor and resistor.
- 6) With bar-type display, by connecting four LEDs in series, power dissipation is reduced.

●Absolute maximum ratings (Ta = 25°C)

Parameter	Symbol	Limits	Unit
Power supply voltage	Vcc	15	V
Power dissipation	Pd	1050*	mW
Operating temperature	Topr	-25~+75	°C
Storage temperature	Tstg	-55~+125	°C

* Reduced by 10.5mW for each increase in Ta of 1°C over 25°C.

● Block diagram

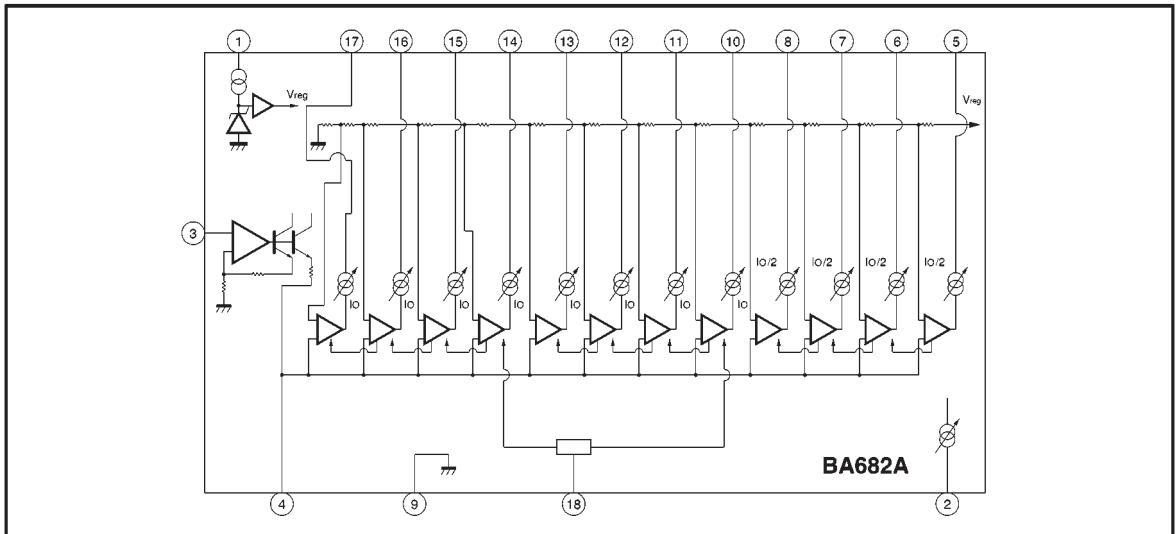
● Electrical characteristics (unless otherwise noted, $T_a = 25^\circ\text{C}$ and $V_{CC} = 12\text{V}$)

Parameter	Symbol	Min.	Typ.	Max.	Unit	Conditions
Power supply voltage	V_{CC}	10	12	14	V	When $V_{F(L\text{LED})} = 2\text{V}$
Quiescent current	I_Q	—	5	10	mA	$V_{IN} = 0\text{V}$
LED current setting range	I_{LED}	—	—	20	mA	Set using R_1 (see Fig. 3)
Pin 5 LED current	I_{LED}	12	15	18	mA	$R_1 = 27\text{k}\Omega$
LED current deviation	ΔI_{LED}	-1.5	0	1.5	mA	$R_1 = 27\text{k}\Omega$ With respect to the pin 5 LED value.
Sensitivity	V_{IN}	0.09	0.13	0.18	V_{rms}	On level for comparator 8.
Comparator level 1	V_{C1}	—	-20	—	dB	Pin 17 output (use VR_1 to adjust the offset)
Comparator level 2	V_{C2}	-16.5	-15	-13.5	dB	Pin 16 output
Comparator level 3	V_{C3}	-11.5	-10	-8.5	dB	Pin 15 output
Comparator level 4	V_{C4}	-8.0	-7	-6.0	dB	Pin 14 output
Comparator level 5	V_{C5}	-6.0	-5	-4.0	dB	Pin 13 output
Comparator level 6	V_{C6}	-4.0	-3	-2.0	dB	Pin 12 output
Comparator level 7	V_{C7}	-1.5	-1	-0.5	dB	Pin 11 output
Comparator level 8	V_{C8}	—	0	—	dB	Pin 10 output (V_{C8} level is 0dB)
Comparator level 9	V_{C9}	0.5	1	1.5	dB	Pin 8 output
Comparator level 10	V_{C10}	2.0	3	4.0	dB	Pin 7 output
Comparator level 11	V_{C11}	4.0	5	6.0	dB	Pin 6 output
Comparator level 12	V_{C12}	6.5	8	9.5	dB	Pin 5 output

● Measurement circuit

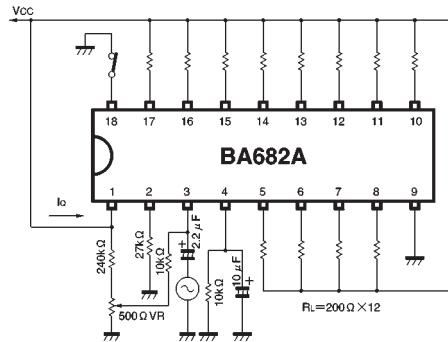

Fig. 1

● Comparator level vs. AC and DC input levels

Comparator level Vo	1	2	3	4	5	6	7	8	9	10	11	12
dB display [dB]	-20	-15	-10	-7	-5	-3	-1	0	+1	+3	+5	+8
AC input level [mV _{rms}]	13	23	41	58	73	92	116	130	146	184	231	327
DC input level [mV]	17	30	54	76	96	120	151	170	191	240	302	427

* These values are not guaranteed. Use for reference only.

● Application example

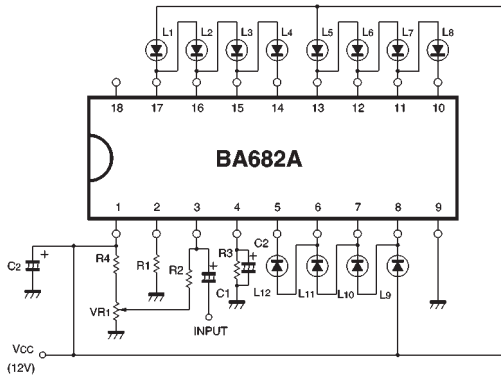

(1) Bar display connections

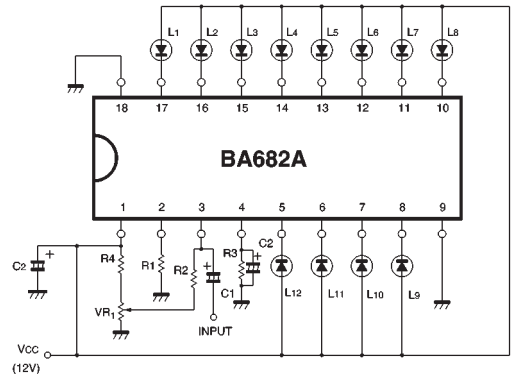

(2) Dot display connections

Note: Ensure that the voltage on the LED current output pins (5 to 8 and 10 to 17) is always 2V or more. If the voltage is below 2V, the current may drop significantly. Take particular care when using high V_F LEDs in bar display applications.

Recommended values
 R1 = 27kΩ (green LED) or 39 to 47kΩ (red LED)
 R2 = 10kΩ C1 = 2.2 μF
 R3 = 10kΩ C2 = 10 μF
 R4 = 240kΩ C3 = 10 μF
 VR1 = 500Ω
 (these values are the same for both bar and dot display)

Fig.2

●Attached components

(1) LED current setting resistor (R_1)

This resistor sets the LED current value. Refer to Fig. 3 for the relationship between the value of this resistor and the current value. The recommended value is $27\text{k}\Omega$ for green LEDs, and $39\text{k}\Omega$ for red LEDs. If the LED current is set too high, the allowable power dissipation of the package may be exceeded, so exercise due caution.

(2) Input coupling capacitor (C_1)

This capacitor connects the BA682A to external input circuits. The recommended value is $2.2\mu\text{F}$.

(3) Input bias resistor (R_2)

This resistor is the input impedance. If the value is set too large, the DC bias voltage will increase, and the input offset will increase and have an effect on the comparators. The recommended value is $10\text{k}\Omega$.

(4) Resistor and capacitor that set the LED operation level discharge time constant (R_3 and C_2)

These components set the discharge time constant for LED operation level. The recommended values are $R_3 = 10\text{k}\Omega$ and $C_2 = 10\mu\text{F}$.

(5) Input offset adjustment resistors (R_4 and VR_1)

These resistors are used to adjust the input offset for the rectifier amplifier.

●Operation notes

(1) LED connection

Connect the LEDs as indicated in Fig. 2. Note that the connection methods are different for bar and dot displays, and that in the case of bar display, pin 18 is open, while for dot display, pin 18 is connected to GND.

When using different color LEDs that have different current values (e.g. green for the lower 10 LEDs and red for the top two) set the value of the current to the larger LED current using the external resistor, and adjust the current value for LEDs that require a smaller current by connecting resistors in parallel them. If you wish to remove LEDs, do so from the lowest level.

(except when the 12th LED is not used for display alignment). Be certain to short unused LEDs.

(2) LED current adjustment

The LED current is set using R_1 . The relationship between the value of R_1 and the typical LED current is given in Fig. 3.

The recommended values are $R_4 = 240\text{k}\Omega$, and $VR_1 = 500\Omega$. If the value of VR_1 is too high, adjustment becomes difficult, and if it is too small, adjustment may not be possible.

(6) Power supply capacitor (C_3)

This capacitor stabilizes the power supply line. The recommended value is $10\mu\text{F}$. This capacitor will have no effect if its value is $1\mu\text{F}$ or less.

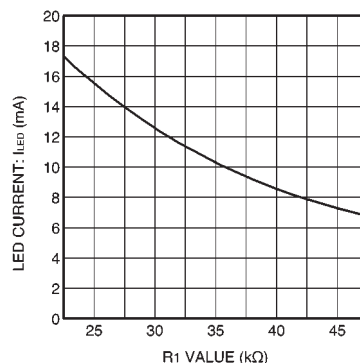

Fig. 3 LED current vs. R_1 setting

(3) Comparator voltage

In the case of the BA682A, the comparator voltage is the input voltage when about half LED current setting value (typ.) is flowing in an LED.

Therefore, if the LED current is set to 16mA , the comparator voltage is the value when 8mA is flowing in the LED.

(4) 0dB and input offset adjustment

First, adjust the input signal so that the 8th LED lights. This is the 0dB input signal level. Next, lower the input signal level to -20dB , and adjust the offset adjustment potentiometer VR_1 so that the first LED lights. Repeat the 0dB and -20dB adjustments alternately to accurately set the levels. The input level at which an LED lights is the comparator voltage.

(5) The BA682A GND (pin 9) and the external component earths should be connected together at one point.

●Tape deck application example

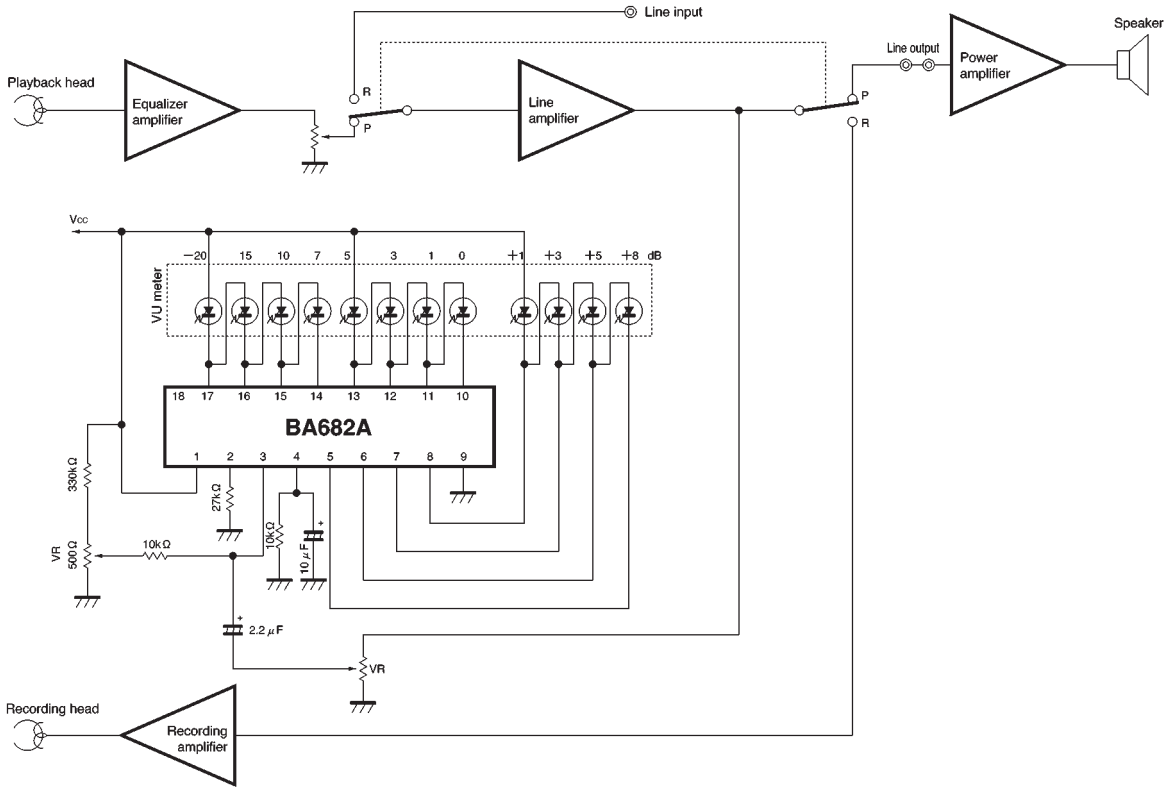

Fig. 4

●External dimensions (Units: mm)

