



Chipsmall Limited consists of a professional team with an average of over 10 year of expertise in the distribution of electronic components. Based in Hongkong, we have already established firm and mutual-benefit business relationships with customers from,Europe,America and south Asia,supplying obsolete and hard-to-find components to meet their specific needs.

With the principle of “Quality Parts,Customers Priority,Honest Operation,and Considerate Service”,our business mainly focus on the distribution of electronic components. Line cards we deal with include Microchip,ALPS,ROHM,Xilinx,Pulse,ON,Everlight and Freescale. Main products comprise IC,Modules,Potentiometer,IC Socket,Relay,Connector.Our parts cover such applications as commercial,industrial, and automotives areas.

We are looking forward to setting up business relationship with you and hope to provide you with the best service and solution. Let us make a better world for our industry!



Contact us

Tel: +86-755-8981 8866 Fax: +86-755-8427 6832

Email & Skype: info@chipsmall.com Web: www.chipsmall.com

Address: A1208, Overseas Decoration Building, #122 Zhenhua RD., Futian, Shenzhen, China





Small Signal Switching Diodes, High Voltage

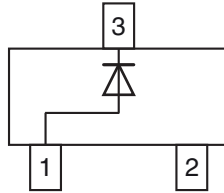

FEATURES

- Silicon epitaxial planar diode
- Fast switching diode in case SOT-23, especially suited for automatic insertion.
- AEC-Q101 qualified
- Base P/N-E3 - RoHS-compliant, commercial grade
- Base P/N-HE3 - RoHS-compliant, AEC-Q101 qualified
- Material categorization: For definitions of compliance please see www.vishay.com/doc?99912



RoHS COMPLIANT

MECHANICAL DATA

Case: SOT-23

Weight: approx. 8.8 mg

Packaging codes/options:

18/10K per 13" reel (8 mm tape), 10K/box

08/3K per 7" reel (8 mm tape), 15K/box

PARTS TABLE					
PART	TYPE DIFFERENTIATION	ORDERING CODE	TYPE MARKING	INTERNAL CONSTRUCTION	REMARKS
BAS19	$V_R = 100\text{ V}$	BAS19-E3-08 or BAS19-E3-18	A8	Single diode	Tape and reel
		BAS19-HE3-08 or BAS19-HE3-18			
BAS20	$V_R = 150\text{ V}$	BAS20-E3-08 or BAS20-E3-18	A81	Single diode	Tape and reel
		BAS20-HE3-08 or BAS20-HE3-18			
BAS21	$V_R = 200\text{ V}$	BAS21-E3-08 or BAS21-E3-18	A82	Single diode	Tape and reel
		BAS21-HE3-08 or BAS21-HE3-18			

ABSOLUTE MAXIMUM RATINGS ($T_{amb} = 25\text{ }^\circ\text{C}$, unless otherwise specified)					
PARAMETER	TEST CONDITION	PART	SYMBOL	VALUE	UNIT
Continuous reverse voltage		BAS19	V_R	100	V
		BAS20	V_R	150	V
		BAS21	V_R	200	V
Repetitive peak reverse voltage		BAS19	V_{RRM}	120	V
		BAS20	V_{RRM}	200	V
		BAS21	V_{RRM}	250	V
Non repetitive peak forward current	$t = 1\text{ }\mu\text{s}$		I_{FSM}	2.5	A
Non repetitive peak forward surge current	$t = 1\text{ s}$		I_{FSM}	0.5	A
Maximum average forward rectified current ⁽¹⁾	(av. over any 20 ms period)		$I_{F(AV)}$	200	mA
DC forward current ⁽²⁾			I_F	200	mA
Repetitive peak forward current			I_{FRM}	625	mA
Power dissipation ⁽²⁾			P_{tot}	250	mW

Notes

⁽¹⁾ Measured under pulse conditions; pulse time = $t_p \geq 0.3\text{ ms}$

⁽²⁾ Device on fiberglass substrate, see layout on next page



THERMAL CHARACTERISTICS ($T_{amb} = 25\text{ }^{\circ}\text{C}$, unless otherwise specified)				
PARAMETER	TEST CONDITION	SYMBOL	VALUE	UNIT
Thermal resistance junction to ambient air		$R_{thJA}^{(1)}$	430	$^{\circ}\text{C}$
Junction temperature		T_j	150	$^{\circ}\text{C}$
Storage temperature range		T_{stg}	- 65 to + 150	$^{\circ}\text{C}$
Operating temperature range		T_{op}	- 55 to + 150	$^{\circ}\text{C}$

Note

(1) Device on fiberglass substrate, see layout drawing below

ELECTRICAL CHARACTERISTICS ($T_{amb} = 25\text{ }^{\circ}\text{C}$, unless otherwise specified)							
PARAMETER	TEST CONDITION	PART	SYMBOL	MIN.	TYP.	MAX.	UNIT
Forward voltage	$I_F = 100\text{ mA}$		V_F			1.0	V
	$I_F = 200\text{ mA}$		V_F			1.25	V
Leakage current	$V_R = 100\text{ V}$	BAS19	I_R			100	nA
	$V_R = 150\text{ V}$	BAS20	I_R			100	nA
	$V_R = 200\text{ V}$	BAS21	I_R			100	nA
	$V_R = V_{Rmax}, T_j = 150\text{ }^{\circ}\text{C}$		I_R			100	μA
Dynamic forward resistance	$I_F = 10\text{ mA}$		r_f		5		Ω
Diode capacitance	$V_R = 0, f = 1\text{ MHz}$		C_D			5	pF
Reverse recovery time	$I_F = I_R = 30\text{ mA}, R_L = 100\text{ }\Omega, i_R = 3\text{ mA}$		t_{rr}			50	ns

LAYOUT FOR R_{thJA} TEST

Thickness:

Fiberglass 1.5 mm (0.059 inches)

Copper leads 0.3 mm (0.012 inches)

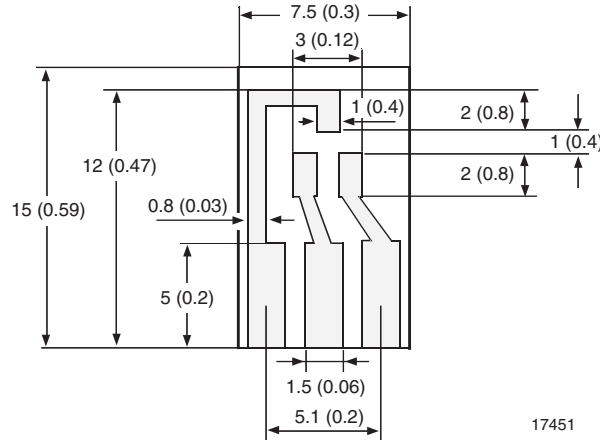



PACKAGE DIMENSIONS in millimeters (inches): SOT-23

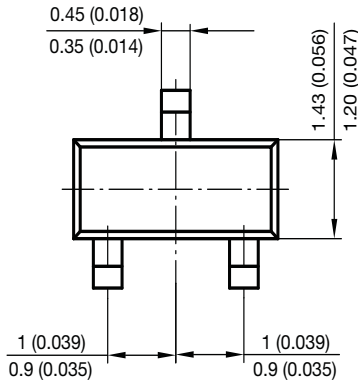
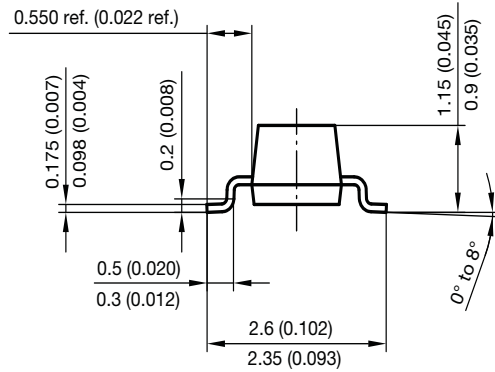
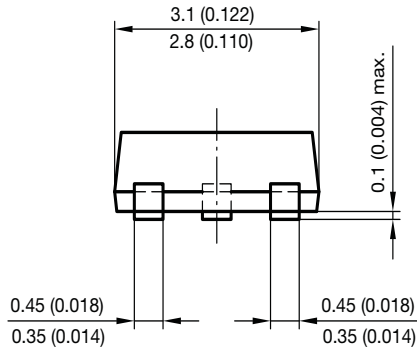

Foot print recommendation:

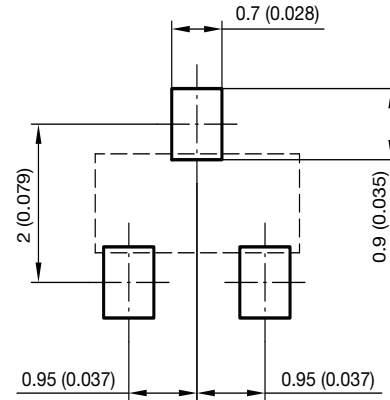

Document no.: 6.541-5014.01-4
 Rev. 8 - Date: 23.Sept.2009
 17418



Disclaimer

ALL PRODUCT, PRODUCT SPECIFICATIONS AND DATA ARE SUBJECT TO CHANGE WITHOUT NOTICE TO IMPROVE RELIABILITY, FUNCTION OR DESIGN OR OTHERWISE.

Vishay Intertechnology, Inc., its affiliates, agents, and employees, and all persons acting on its or their behalf (collectively, "Vishay"), disclaim any and all liability for any errors, inaccuracies or incompleteness contained in any datasheet or in any other disclosure relating to any product.

Vishay makes no warranty, representation or guarantee regarding the suitability of the products for any particular purpose or the continuing production of any product. To the maximum extent permitted by applicable law, Vishay disclaims (i) any and all liability arising out of the application or use of any product, (ii) any and all liability, including without limitation special, consequential or incidental damages, and (iii) any and all implied warranties, including warranties of fitness for particular purpose, non-infringement and merchantability.

Statements regarding the suitability of products for certain types of applications are based on Vishay's knowledge of typical requirements that are often placed on Vishay products in generic applications. Such statements are not binding statements about the suitability of products for a particular application. It is the customer's responsibility to validate that a particular product with the properties described in the product specification is suitable for use in a particular application. Parameters provided in datasheets and / or specifications may vary in different applications and performance may vary over time. All operating parameters, including typical parameters, must be validated for each customer application by the customer's technical experts. Product specifications do not expand or otherwise modify Vishay's terms and conditions of purchase, including but not limited to the warranty expressed therein.

Except as expressly indicated in writing, Vishay products are not designed for use in medical, life-saving, or life-sustaining applications or for any other application in which the failure of the Vishay product could result in personal injury or death. Customers using or selling Vishay products not expressly indicated for use in such applications do so at their own risk. Please contact authorized Vishay personnel to obtain written terms and conditions regarding products designed for such applications.

No license, express or implied, by estoppel or otherwise, to any intellectual property rights is granted by this document or by any conduct of Vishay. Product names and markings noted herein may be trademarks of their respective owners.