



Chipsmall Limited consists of a professional team with an average of over 10 year of expertise in the distribution of electronic components. Based in Hongkong, we have already established firm and mutual-benefit business relationships with customers from,Europe,America and south Asia,supplying obsolete and hard-to-find components to meet their specific needs.

With the principle of “Quality Parts,Customers Priority,Honest Operation,and Considerate Service”,our business mainly focus on the distribution of electronic components. Line cards we deal with include Microchip,ALPS,ROHM,Xilinx,Pulse,ON,Everlight and Freescale. Main products comprise IC,Modules,Potentiometer,IC Socket,Relay,Connector.Our parts cover such applications as commercial,industrial, and automotives areas.

We are looking forward to setting up business relationship with you and hope to provide you with the best service and solution. Let us make a better world for our industry!



Contact us

Tel: +86-755-8981 8866 Fax: +86-755-8427 6832

Email & Skype: info@chipsmall.com Web: www.chipsmall.com

Address: A1208, Overseas Decoration Building, #122 Zhenhua RD., Futian, Shenzhen, China



REVISIONS			
REV	DESCRIPTION	DATE	APPV
A	INITIAL RELEASE OF INTERNAL DOCUMENT	2-FEB-12	SAH
B	ADDED PART NUMBER TABLE AND SECOND SHEET; UPDATED NOTE 3	23-JUL-18	CLL

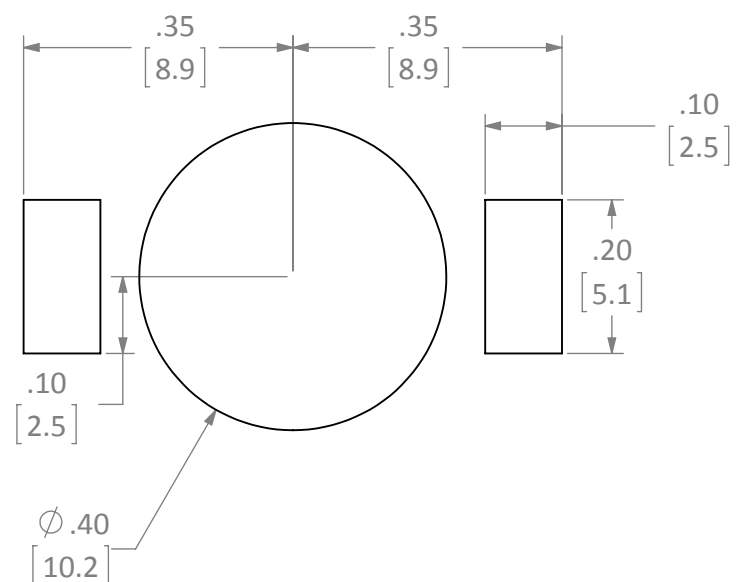
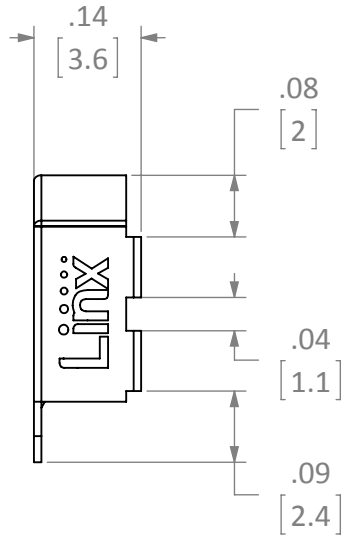
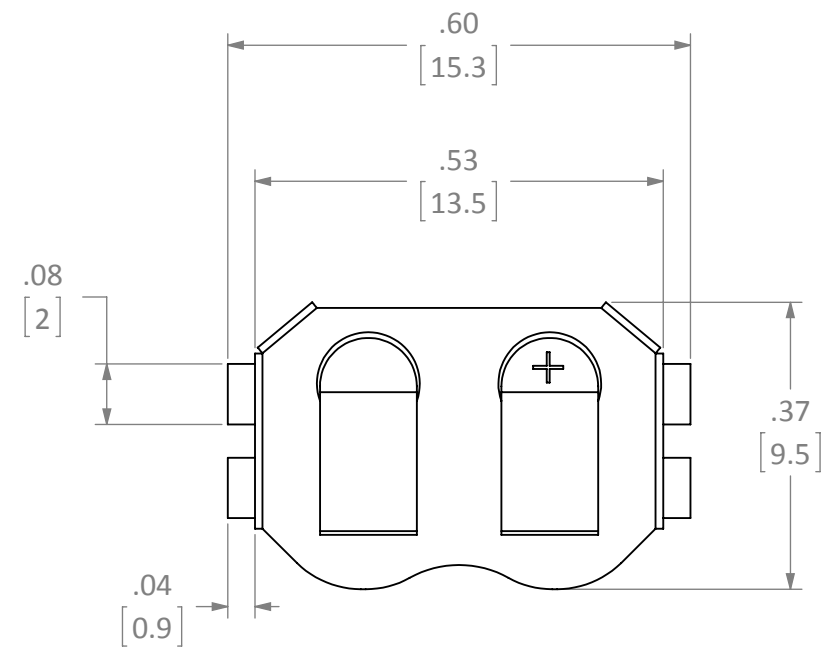

RECOMMENDED FOOTPRINT

- NOTES: (UNLESS OTHERWISE SPECIFIED)
1. ALL DIMENSIONS ARE IN INCHES [mm].
 2. DIMENSIONS APPLY AFTER FINISHING.
 3. MANUFACTURE TO BE COMPLIANT WITH EU RoHS DIRECTIVE, USE MATERIALS THAT DO NOT CONTAIN REACH SUBSTANCES OF VERY HIGH CONCERN >1000ppm, AND USE DRC CONFLICT-FREE SOURCED MATERIALS.
 4. SAFETY BREAK ALL SHARP CORNERS AND EDGES .02 MAXIMUM.

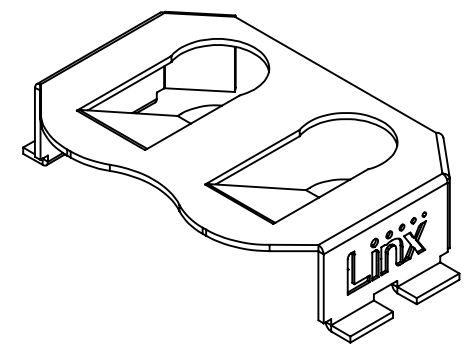

PART NUMBER	PACKAGING
BAT-HLD-012-SMT	BULK
BAT-HLD-012-SMT-TR	TAPE & REEL

WARNING: THIS DRAWING CONTAINS PROPRIETARY INFORMATION THAT IS THE SOLE PROPERTY OF LINX TECHNOLOGIES, AND SHALL BE TREATED AS SUCH. NO DISCLOSURE OR REPRODUCTION OF THIS DOCUMENT IS PERMITTED, IN WHOLE OR IN PART, WITHOUT THE EXPRESS WRITTEN PERMISSION OF LINX TECHNOLOGIES OR ITS DESIGNATED AGENTS.		159 ORT LANE MERLIN, OR 97532	
MATERIAL: INTERPRET DIMENSIONS AND TOLERANCES PER ASME Y14.5.		PROJECTION:	
SURFACE FINISH: $\sqrt{32}$ ANGLES: $\pm 1^\circ$		TITLE: CR1216,1225 HOLDER OUTLINE SURFACE MOUNT	
TOLERANCES: .X \pm .1 .XX \pm .01 .XXX \pm .005		SIZE: B	DWG. NO.: BAT-HLD-012-SMT-OTL
FINISH: DRAWN: B.MURPHY DT: 2-FEB-12		SCALE: 4:1	REV: B
ENGR: S.HOGAN DT: 2-FEB-12		DO NOT SCALE DRAWING	SHEET 1 OF 2

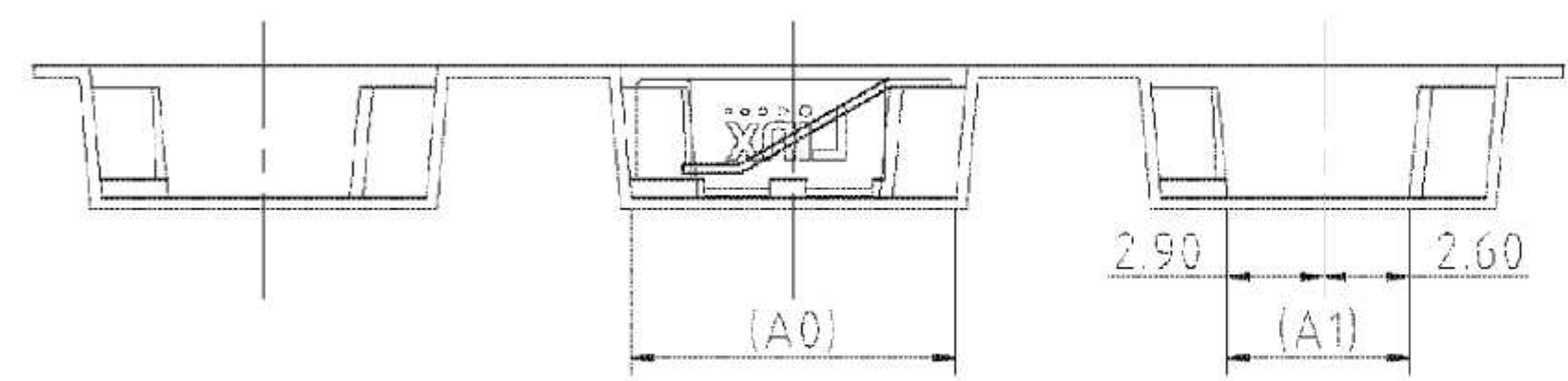
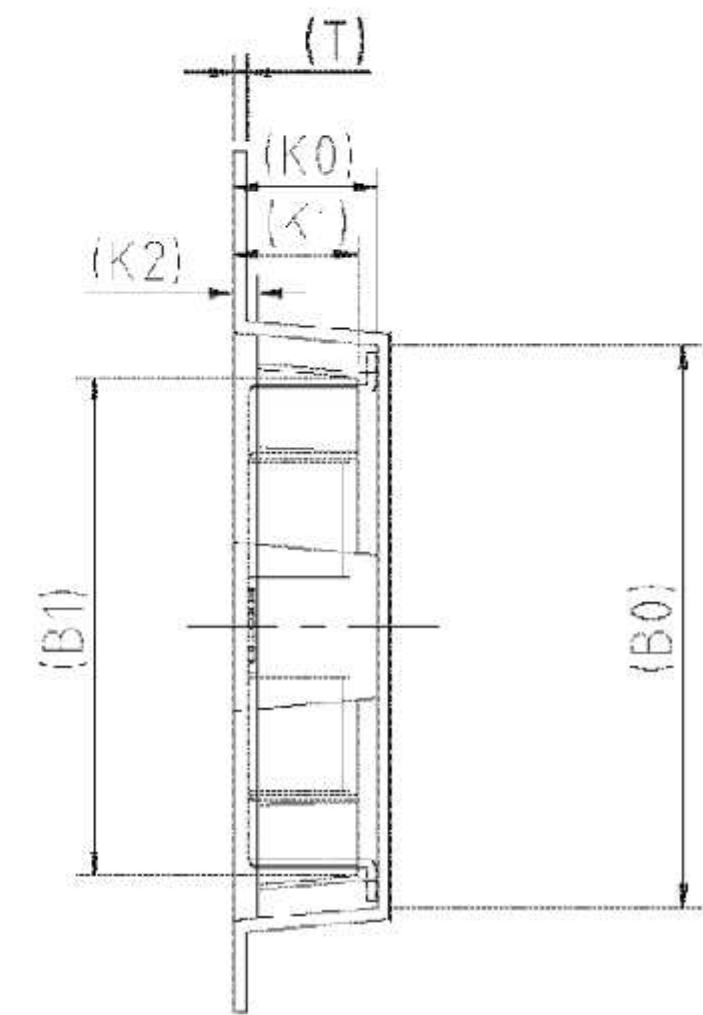
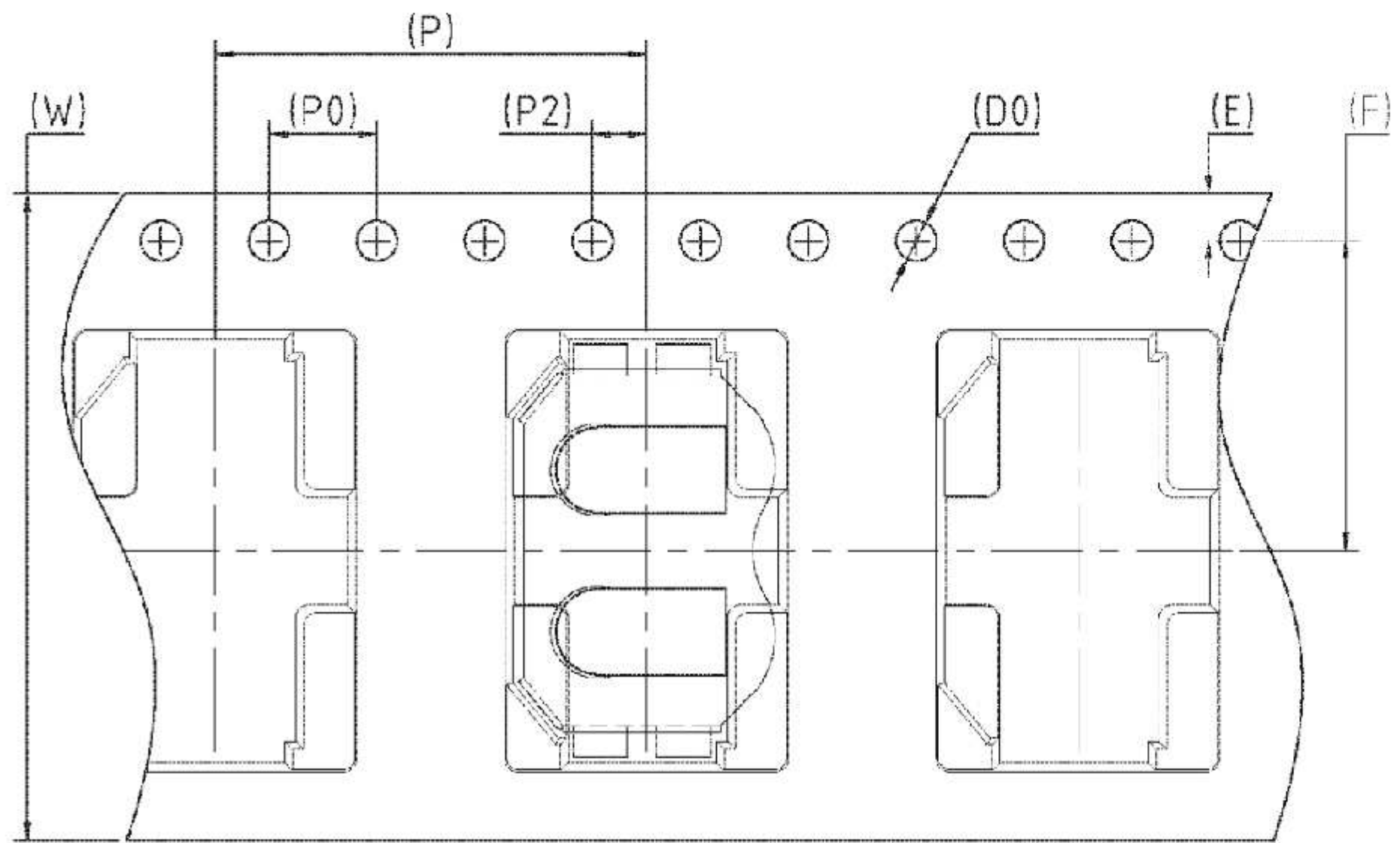

- NOTES: (UNLESS OTHERWISE SPECIFIED)
1. ALL DIMENSIONS ARE IN MILLIMETERS [INCHES].
 2. 10 SPROCKET HOLE PITCH CUMULATIVE TOLERANCE ± 0.2 mm.
 3. MATERIAL: BLACK POLYSTYRENE.
 4. PACKING LENGTH PER 22" REEL: 51.0 m.
 5. COMPONENT LOAD PER 13" REEL: 1000.
 6. ANGLE TOLERANCE: $\pm 1^\circ$
 7. CARRIER CAMBER IS WITHIN 1 mm IN 250 mm.

W	24.00 \pm 0.30	P	16.00 \pm 0.10	A0	9.80 \pm 0.10	B0	15.70 \pm 0.10
S		P0	4.00 \pm 0.10	A1	5.50 \pm 0.10	B1	13.90 \pm 0.10
E	1.75 \pm 0.10	P2	2.00 \pm 0.10	A2		B2	
F	11.50 \pm 0.10	D0	$\phi 1.50^{+0.10}_{-0.00}$	K0	4.00 \pm 0.10	K2	0.65 \pm 0.10
T	0.35 \pm 0.05	D1		K1	3.45 \pm 0.10	COLOR: BK/ANT	