



Chipsmall Limited consists of a professional team with an average of over 10 year of expertise in the distribution of electronic components. Based in Hongkong, we have already established firm and mutual-benefit business relationships with customers from,Europe,America and south Asia,supplying obsolete and hard-to-find components to meet their specific needs.

With the principle of “Quality Parts,Customers Priority,Honest Operation,and Considerate Service”,our business mainly focus on the distribution of electronic components. Line cards we deal with include Microchip,ALPS,ROHM,Xilinx,Pulse,ON,Everlight and Freescale. Main products comprise IC,Modules,Potentiometer,IC Socket,Relay,Connector.Our parts cover such applications as commercial,industrial, and automotives areas.

We are looking forward to setting up business relationship with you and hope to provide you with the best service and solution. Let us make a better world for our industry!



Contact us

Tel: +86-755-8981 8866 Fax: +86-755-8427 6832

Email & Skype: info@chipsmall.com Web: www.chipsmall.com

Address: A1208, Overseas Decoration Building, #122 Zhenhua RD., Futian, Shenzhen, China



Carrier HVAC Converter CE

Includes Send Data Control

Model 485CARLP9A

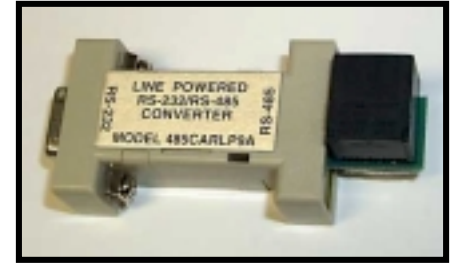

The Model 485CARLP9A is an RS-232 to RS-485 converter that allows you to connect your laptop PC to Carrier HVAC equipment.

The 485CARLP9A is a port-powered, half-duplex RS-232 to RS-485 converter with send data control. The unit converts TD and RD RS-232 lines to balanced RS-485 signals and supports three-wire (Data A, B, and Signal Ground reference) RS-485 communications only. The converter is powered from the RS-232 handshake lines, RTS, CTS and DTR, DSR, CD. The handshake lines are looped back on each other and can be in either state. No handshake change is necessary so no software is required to control the lines. The RS-485 driver is enabled with each bit of data. The RS-485 receiver is disabled when the driver is enabled and is enabled when the driver is disabled. This prevents data from being echoed back into the RS-232 device. The RS-232 side has a DB-9 female connector. The RS-485 side has a six-position RJ11 connector.

NOTE: This converter is not optically isolated.

Connections

Regardless of the system, the 485CARLP9A must be connected with the proper polarity (See Table 1). With no data being sent and the driver enabled, the RS-232 line should be negative and the Data(A) should be negative with respect to Data(B).

Proper operation of any RS-485 system requires the presence of a signal return path between the signal grounds of the equipment at each end of an interconnection. This circuit reference may be established by a third conductor connecting the common leads of devices, or it may be provided by connections in each equipment to an earth reference. When the circuit reference is provided by a third conductor, the connection between the signal grounds and the third conductor should contain some resistance (e.g. 100 ohms) to limit circulating currents when other ground connections are provided for safety.

Modular Connector Pin Assignment

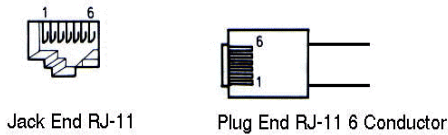

Table 1: 485CARLP9A Pin-Outs

Signal	RJ11 Pin #
Data A (-)	2
Data B (+)	5
Signal Ground	4

Specifications

Communication: Two-wire with Signal Ground reference
 Data Rate: 115.2K Baud max.
 Power: Port-powered from handshake lines
 Dimensions: 3.0 x 1.3 x 0.9 in
 Temperature Range: 0°C to 70°C

DECLARATION OF CONFORMITY

Manufacturer's Name: B&B Electronics Manufacturing Company
 Manufacturer's Address: P.O. Box 1040
 707 Dayton Road
 Ottawa, IL 61350 USA

Model Number: 485CARLP9A
 Description: RS-232 to RS-485 Data Converter with
 Send Data Control, Port-powered, DB9 to RJ45

Type: Light industrial ITE equipment

Application of Council
 Directive: 89/336/EEC

Standards: EN 50082-1 (IEC 801-2, IEC 801-3, IEC 801-4)
 EN 50081-1 (EN 55022, IEC 1000-4-2)
 EN 61000 (-4-2, -4-3, -4-4, -4-5, -4-6, -4-8, -4-11)
 ENV 50204
 EN 55024

MJ Fahrion

Michael J. Fahrion, Director of Engineering

CE

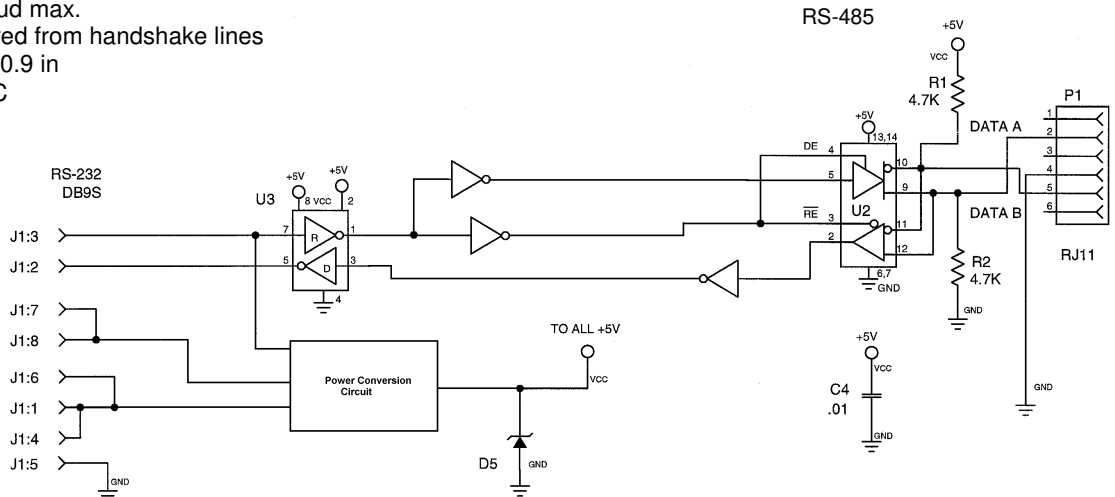

© B&B Electronics – Revised November 2000

This product designed and manufactured in USA of domestic and imported parts by

B & B Electronics Mfg. Co.
 707 Dayton Road - P.O. Box 1040 - Ottawa, IL 61350 USA
 Phone: (815) 433-5100 - Fax: (815) 433-5105
 Home Page: www.bb-elec.com
 Sales e-mail: orders@bb-elec.com - Fax: (815) 433-5109
 Technical Support e-mail: support@bb-elec.com - Fax: (815) 433-5104

B & B Electronics Ltd
 Westlink Commercial Park - Oranmore, Co. Galway - Ireland
 Phone: +353 91 792444 - Fax: +353 91 792445
 Home Page: www.bb-europe.com
 Sales e-mail: orders@bb-europe.com
 Technical Support e-mail: support@bb-europe.com