



Chipsmall Limited consists of a professional team with an average of over 10 year of expertise in the distribution of electronic components. Based in Hongkong, we have already established firm and mutual-benefit business relationships with customers from,Europe,America and south Asia,supplying obsolete and hard-to-find components to meet their specific needs.

With the principle of “Quality Parts,Customers Priority,Honest Operation,and Considerate Service”,our business mainly focus on the distribution of electronic components. Line cards we deal with include Microchip,ALPS,ROHM,Xilinx,Pulse,ON,Everlight and Freescale. Main products comprise IC,Modules,Potentiometer,IC Socket,Relay,Connector.Our parts cover such applications as commercial,industrial, and automotives areas.

We are looking forward to setting up business relationship with you and hope to provide you with the best service and solution. Let us make a better world for our industry!



## Contact us

Tel: +86-755-8981 8866 Fax: +86-755-8427 6832

Email & Skype: info@chipsmall.com Web: www.chipsmall.com

Address: A1208, Overseas Decoration Building, #122 Zhenhua RD., Futian, Shenzhen, China



# SNMP-Manageable Chassis

## - for "iMcV" Series Modular Media Converters

iMediaChassis/20 series

B+B SMARTWORX

Powered by

ADVANTECH

www.advantech-bb.com



### PRODUCT FEATURES

- 20-slot chassis supporting low to high density deployment
- Install wide varieties of media conversion and optical demarcation modules
- SNMP management using optional SNMP management module
- 19" rack or rack shelf mountable
- Dual (redundant) AC or DC power supplies and fans

The iMediaChassis/20 is an intelligent, carrier-class optical access platform that supports modules which provide conversion of Ethernet to fiber and a variety of other telco networking technologies, including VDSL2, T1/E1, and DS3/E3/STS-1. The iMediaChassis/20 enables network operators to drastically reduce the capital and operational expenses by providing copper-to-fiber, multi-mode to single-mode fiber and TDM conversions in a variety of speeds ranging from 10Mbps up to 10GB from the same managed chassis platform. Having the highest port density in the industry - along with a robust design, hot-swappable architecture, SNMP-management, and redundant power supplies for fault tolerance - makes the iMediaChassis ideal for installing in the Central Office (CO) where a multitude of diverse applications, using a variety of protocols, is required. Pair this multi-slot chassis with a MediaChassis or other standalone B+B SmartWorx unmanaged device at the customer premises, for complete end-to-end management.

- A designated SNMP-Management slot to allow management of all iMcV-Modules in the chassis using one IP address
- Fans on the 20-slot chassis can be remotely controlled via SNMP
- Remote temperature monitoring on all chassis



Webserver Version iView<sup>2</sup> - free download from website.

### ORDERING INFORMATION

MODEL NUMBER	DESCRIPTION
<b>iMediaChassis/20 *</b>	
<b>605-10144-2AC</b>	Includes 2 AC power supply modules
<b>605-10145-2DC</b>	Includes 2 DC power supply modules

\*An SNMP module is required to utilize full SNMP functionality in the iMediaChassis family.

### ACCESSORIES

- 850-39950 – iMediaChassis SNMP Management Module
- 605-10144-AC – AC Power Supply (300 W, 100-240V AC)
- 605-10145-DC – DC Power Supply (300 W, -48V DC)



SNMP module (optional)  
# 850-39950

All product specifications are subject to change without notice.  
iMediaChassis/20\_3517ds



# SNMP-Manageable Chassis

## - for "iMcV" Series Modular Media Converters

iMediaChassis/20 series



### SPECIFICATIONS

TECHNICAL	
SNMP-manageable with use of SNMP module	
SNMP Write Lock switch protects the SNMP-configured settings	
Last Gasp feature sends notification of AC line failures and power supply failures	
Available with AC or DC power	
Available with redundant power	
Highest port density, 20 slots	
Includes fan tachometers	
MIB:	
Port Type	
Fan Speeds	
Traps	
Fiber Type	
Module Type	
Link Status of Ports	
Chassis Temperature	
Power Supply Type/Status	
User-Definable Name/ID of Product and Each Port	
Enable/Disable Ports	
Enable/Disable FO/FX LinkLoss, TP/TX LinkLoss	
Enable/Disable FiberAlert, Auto Negotiation	

MECHANICAL	
Dimensions	13.13H x 48.26W x 35.56D cm (5.17H x 19.0W x 14D inches)
Shipping Weight	13.60 kg (30 lbs)
AC INPUT LOAD: DUAL AC	
605-10144-AC series:	100 to 240V AC $\pm$ 10%, 50-60Hz, 4.5/2A
DC INPUT LOAD: DUAL DC	
605-10145-DC series:	-48V DC, 9A
ENVIRONMENTAL	
Operating Temperature:	0° to +50° C (+32° to +122° F)
Storage Temperature:	-20° to +80° C (-4° to +176° F): Dual AC, AC/DC -20° to +60° C (-4° to +140° F): Dual DC
Operating Humidity	5 to 95% (non-condensing) 0 – 10000 ft. altitude
REGULATORY APPROVALS	
Dual AC:	FCC Class B
Dual DC:	FCC Class B
UL/cUL, CSA, CE	
MEANTIME BEFORE FAILURE (MTBF)	
MTBF	Dual AC: 678497 hours Dual DC: 678497 hours

### MECHANICAL DIAGRAM

(dimensions in inches)

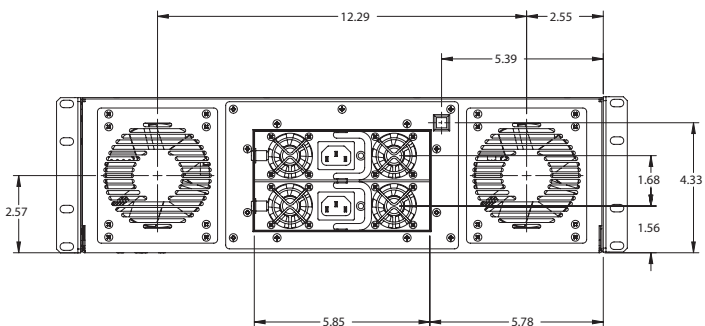
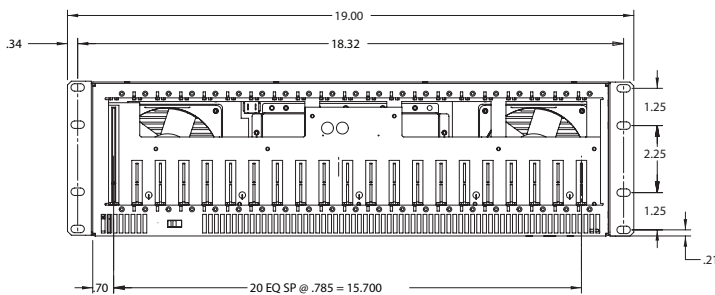

Chassis shown with optional power supply.  
Power supplies available for purchase, depending on chassis style.

