



Chipsmall Limited consists of a professional team with an average of over 10 year of expertise in the distribution of electronic components. Based in Hongkong, we have already established firm and mutual-benefit business relationships with customers from,Europe,America and south Asia,supplying obsolete and hard-to-find components to meet their specific needs.

With the principle of "Quality Parts,Customers Priority,Honest Operation,and Considerate Service",our business mainly focus on the distribution of electronic components. Line cards we deal with include Microchip,ALPS,ROHM,Xilinx,Pulse,ON,Everlight and Freescale. Main products comprise IC,Modules,Potentiometer,IC Socket,Relay,Connector.Our parts cover such applications as commercial,industrial, and automotives areas.

We are looking forward to setting up business relationship with you and hope to provide you with the best service and solution. Let us make a better world for our industry!



Contact us

Tel: +86-755-8981 8866 Fax: +86-755-8427 6832

Email & Skype: info@chipsmall.com Web: www.chipsmall.com

Address: A1208, Overseas Decoration Building, #122 Zhenhua RD., Futian, Shenzhen, China



Industrial 10/100BASE-TX Ethernet Copper Extender

EIS2-EXTEND



19-inch rack system with power supply



Optional, additional power supply

The model EIS2-EXTEND extends your copper Ethernet connections up to 2600 meters (8,530 feet) over twisted pair wire. The Ethernet Extender fully complies with IEEE 802.3 10BaseT and IEEE 802.3u 100BaseTX standards. Two EIS2-EXTEND models are required for the Ethernet extension, (one at each end of your extension points). The EIS2-EXTEND's design features high shock, vibration, electrical noise immunity, a wide operating temperature range from -10C to 60C and ruggedized housing. The EIS2-EXTEND can be used with included power supply or in the EIS-RACK-16, 19-inch rack mount chassis used to house up to 16 EIS2-EXTEND units.

PRODUCT FEATURES

- Extend Ethernet Copper up to 2600 meters (8,530 feet) over existing copper wire (common copper, telephone, Cat5e)
- VDSL2 technology with transmission rate of 100Mbps at 300meters
- Auto -detection of Local/Remote function to reduce installation time
- Symmetric mode where downstream and upstream TX are important
- Asymmetric mode where single TX like CCTV requires larger BW
- Auto negotiation of speed and duplex mode on TX port
- Performance / Standard mode to adjust SNR according to line quality
- One 10/100Base TX (TX) Ethernet port with RJ-45 connector
- IEEE 802.3 10BaseT and IEEE 802.3u 100BaseTX compliant
- Line port uses common RJ-11 connector
- One DIP switch for configuring local or remote mode
- Status LEDs for speed, monitoring and connection status
- External AC to DC power adapter included
- Used as a stand-alone device or with a 19-inch rack chassis
- Hot-swappable when used in 19 inch rack chassis

ORDERING INFORMATION

MODEL NUMBER	DESCRIPTION	POWER SUPPLY (INCLUDED)
EIS2-EXTEND	Industrial 10/100BASE-TX Ethernet Extender	USA

ACCESSORIES

- EIS-PS-US - Replacement Power supply 12V US Plug
- EIS-PS-EU - Replacement Power supply 12V EU plug
- EIS-PS-UK - Replacement Power supply 12V UK plug
- EIS-RACK-PS - Power Supply For EIS-RACK-16, 84 Watts
- EIS-RACK-16 - Media Converter 19 Inch 2U Rack Chassis - 16 Slots
- C5UMB3FBG - 3 ft. (1 M) - Beige - Category 5e UTP Patch Cord

Industrial 10/100BASE-TX Ethernet Copper Extender

EIS2-EXTEND



SPECIFICATIONS

TECHNOLOGY	
Standards	IEEE802.3 10BASE-T, IEEE802.3u 100BASE-TX, IEEE802.3x
Protocols	Transparent to higher layer protocols
Processing Type	Half-duplex back-pressure and IEEE802.3x Full-duplex flow control
Forward and Filtering Rate	14,880pps for 10Mbps; 148,810pps for 100Mbps
INTERFACE	
Ethernet Port	Port: One RJ-45 port, 10/100BASE-TX Full/Half-duplex Auto-Negotiation, Auto-MDI/MDIX Speed: 10/100Mbps Distance: 100meters (328 ft.) Cable: 10BASE-T: UTP CAT. 3, 4, 5 (2-pair wire) 100BASE-TX: UTP CAT. 5 (4-pair wire) Port: One RJ-11
Extender Port	Distance: 2600 meters (8,530 ft.) Cable: Telephone wire 24AWG (0.5mm diameter, 1-pair) or larger
DIP Switch	DIP Switch 1: AUTO / LOC DIP Switch 3: Perf. / Std. DIP Switch 2: SYM / ASM Per Unit: Power 1
LED Indicators	Per 10/100TX Port: Link/Activity, full-duplex SYM: Symmetric mode (distance ≤ 1000m) ASM: Asymmetric mode RMT: Remote mode LOC: Local mode Per: On/Performance mode - Off/Standard mode
POWER	
Input Voltage	12 VDC
Power Consumption	4.56 W Max. 0.38A @ 12VDC
MECHANICAL	
Enclosure	Aluminum case
Dimensions	8.03W x 10.92D x 2.38H cm (3.16W x 4.30D x 0.94H in)
Weight	150g (0.33 lb.)
Installation	Desktop, DIN-Rail (Top hat type 35mm), wall mounting or 19 inch rack mount chassis system

MECHANICAL DIAGRAM

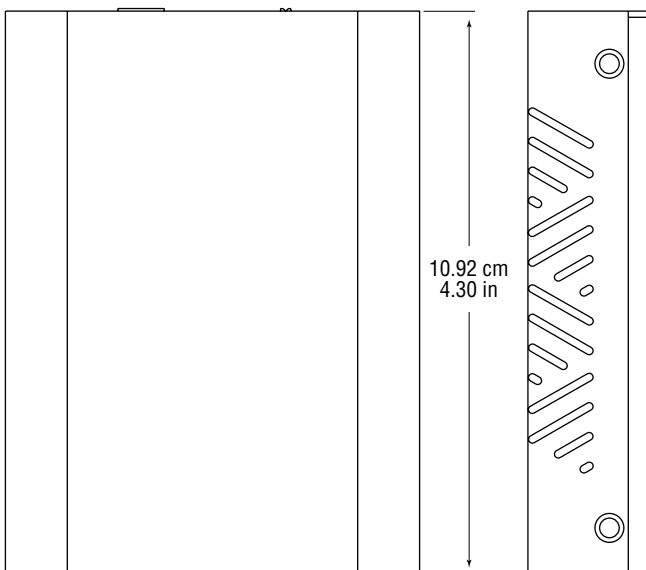

ENVIRONMENTAL	
Operating Temperature	-10°C to 60°C (14°F to 140°F)
Storage Temperature	-20°C to 70°C (-4 to 158°F)
Ambient Relative Humidity	5% to 95% (non-condensing)
REGULATORY APPROVALS	
ISO	Manufactured in an ISO9001 facility
Safety	UL60950-1 / EN60950-1 / IEC60950-1
EMI/EMS	CE FCC Part 15, Class A VCCI Class A EN55022 EN61000-3-2, -3-3, -4-3, -4-4, -4-5, -4-6, -4-8, -6-2, 6-3 IEC60068-2-6 Fc (Vibration Resistance)
Environmental	IEC60068-2-27 Ea (Shock) FED STD 101C Method 5007.1 (Free fall w/package)

PERFORMANCE

DISTANCE (M)	DATA RATE (MBPS)
300	100
400	80
600	60
800	40
...	...
2600	1

Note:

- All speed selections are Symmetrical on the DSL and Full-duplex on the Ethernet
- The data rate will vary according to the line quality

