



Chipsmall Limited consists of a professional team with an average of over 10 year of expertise in the distribution of electronic components. Based in Hongkong, we have already established firm and mutual-benefit business relationships with customers from,Europe,America and south Asia,supplying obsolete and hard-to-find components to meet their specific needs.

With the principle of “Quality Parts,Customers Priority,Honest Operation,and Considerate Service”,our business mainly focus on the distribution of electronic components. Line cards we deal with include Microchip,ALPS,ROHM,Xilinx,Pulse,ON,Everlight and Freescale. Main products comprise IC,Modules,Potentiometer,IC Socket,Relay,Connector.Our parts cover such applications as commercial,industrial, and automotives areas.

We are looking forward to setting up business relationship with you and hope to provide you with the best service and solution. Let us make a better world for our industry!



## Contact us

Tel: +86-755-8981 8866 Fax: +86-755-8427 6832

Email & Skype: info@chipsmall.com Web: www.chipsmall.com

Address: A1208, Overseas Decoration Building, #122 Zhenhua RD., Futian, Shenzhen, China





# WIRED CONNECTIVITY BCM53134

## Six-Port Ultra-Low Power Ethernet Switch

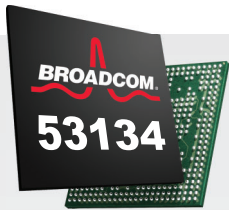

- Four GPHY integrated + 1xRGMII + 1xRGMII/SGMII multilayer Ethernet switch for Home Gateway, Wi-Fi router, and broadband access applications
- 1G/2.5 Gbps SGMII to address growth in bandwidth demand and 802.11ac rollout
- 256-pin, 11 mm x 11 mm FBGA package for improved layout and yield
- Lowest power consumption to meet EU CoC and Energy Efficiency requirements for home and SOHO/SMB gateways
- Six selectable queues per port, plus two time-sensitive queues for efficient delivery of multiple differentiated services

### OVERVIEW

The BCM53134 is Broadcom's lowest power consumption integrated multilayer Ethernet switch for next-generation Home Gateway, SOHO/SMB, and wireless router applications.

Building on industry-leading 28 nm RoboSwitch™ architecture, the BCM53134 allows customers to significantly reduce power consumption of existing designs, while delivering higher performance to meet the growing bandwidth demands in the home and SOHO/SMB environments.

The BCM53134 can connect with other devices for scalable, high-performance systems through multiple interfaces including RGMII and SGMII, at line rates of up to 2.5 Gbps.

Requirements such as video and Internet Protocol (IP) phone services are driving the need for QoS and adherence to industry standards. The BCM53134 supports six selectable classes of service per port, plus two additional time-sensitive classes. It supports SP, WRR, any combination of SP and WRR scheduling, port, MAC, IEEE 802.1P, and IPv4/IPv6 DSCP-based QoS. The BCM53134 delivers the most comprehensive feature set required by top tier service providers for home and SOHO/SMB gateways.

Protocols such as IEEE 802.1Q-based VLAN with 4K entries, port-based VLAN, VLAN double tagging (Q-in-Q), and VLAN translation are fully supported.

### FEATURES

- 4xGPHY integrated, 1xRGMII and 1xRGMII/SGMII cost-effective smart-managed Gigabit switch
- 1G/2.5 Gbps SGMII interface
- Integrated on-chip 8051 microcontroller for cable diagnostics and green-power saving modes
- IEEE 802.1p, MAC Port, TOS, and DiffServ QoS for six queues, plus two time sensitive queues
- 128 Compact field processor (CFP) entries rules
- Broadsync™ HD for IEEE 802.1AS support

### BENEFITS

- Lowest power consumption Gigabit switch for next-gen Broadband home gateway, SOHO/SMB, and wireless router applications
- 11 mm x11 mm 0.65 mm ball pitch FBGA package for improved layout and yield
- 2.5G SGMII interface to address 802.11ac high bandwidth and other 2.5G applications
- Individual ports can automatically detect when short cable lengths are used to scale power appropriately

BCM53134	
✓	Multilayer Switch
✓	Lowest Power
✓	EEE
✓	1G/2.5 Gbps SGMII interface

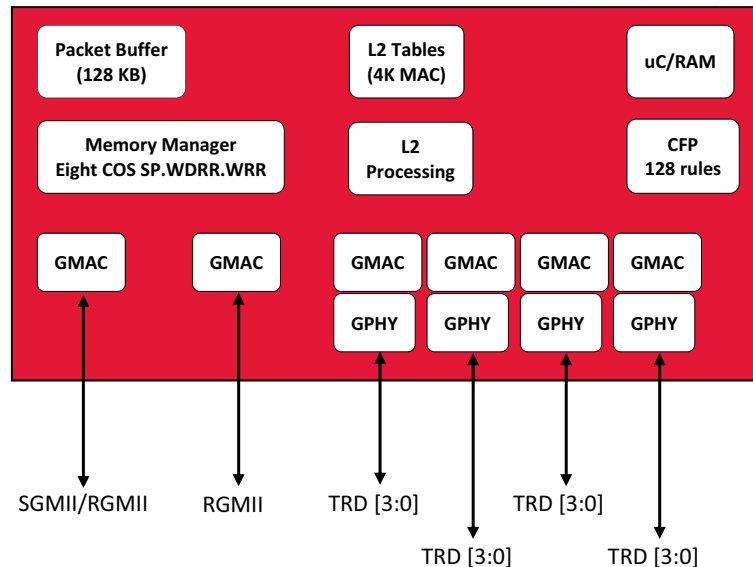

Block Diagram

<b>BCM53134: PRODUCT FAMILY</b>	<b>BCM53134M</b>	<b>BCM53134S</b>	<b>BCM53134P</b>	<b>BCM53134O</b>
Number of Cu ports supported (four GPHYs)	4	4	4	4
RGMI interface	2	2	1	1
SGMI interface	0	0	1	1
Package	11x11 (256-pin)	11x11 (256-pin)	11x11 (256-pin)	11x11 (256-pin)
CFP support	Yes	Not supported	Yes	Not supported
802.11AS	Yes	Yes	Yes	Yes
Link aggregation	Yes	Yes	Yes	Yes
RoHS support	Yes	Yes	Yes	Yes
Cable diagnostics tool support	Yes	Yes	Yes	Yes
LoopDetect tool support	Yes	Yes	Yes	Yes



For more information, visit:  
[www.broadcom.com](http://www.broadcom.com)

#### **ABOUT BROADCOM**

Broadcom Corporation (NASDAQ: BRCM), a FORTUNE 500® company, is a global leader and innovator in semiconductor solutions for wired and wireless communications. Broadcom® products seamlessly deliver voice, video, data, and multimedia connectivity in the home, office, and mobile environments. With the industry's broadest portfolio of state-of-the-art system-on-a-chip and embedded software solutions, Broadcom is changing the world by Connecting everything®. For more information, go to [www.broadcom.com](http://www.broadcom.com).



53134-PB101-R • May 7, 2015

© 2015 Broadcom Corporation. All rights reserved. Broadcom®, the pulse logo, Connecting everything, RoboSwitch™, Broadsync™, SmartPath™, FastPath®, and the Connecting everything logo are among the trademarks of Broadcom Corporation and/or its affiliates in the United States, certain other countries and/or the EU. Any other trademarks or trade names mentioned are the property of their respective owners.