



Chipsmall Limited consists of a professional team with an average of over 10 year of expertise in the distribution of electronic components. Based in Hongkong, we have already established firm and mutual-benefit business relationships with customers from,Europe,America and south Asia,supplying obsolete and hard-to-find components to meet their specific needs.

With the principle of “Quality Parts,Customers Priority,Honest Operation,and Considerate Service”,our business mainly focus on the distribution of electronic components. Line cards we deal with include Microchip,ALPS,ROHM,Xilinx,Pulse,ON,Everlight and Freescale. Main products comprise IC,Modules,Potentiometer,IC Socket,Relay,Connector.Our parts cover such applications as commercial,industrial, and automotives areas.

We are looking forward to setting up business relationship with you and hope to provide you with the best service and solution. Let us make a better world for our industry!



Contact us

Tel: +86-755-8981 8866 Fax: +86-755-8427 6832

Email & Skype: info@chipsmall.com Web: www.chipsmall.com

Address: A1208, Overseas Decoration Building, #122 Zhenhua RD., Futian, Shenzhen, China



LED Driver

Features

- LED drive current of 50mA
- Output current adjustable up to 65mA with external resistor
- Supply voltage up to 40V
- Easy paralleling of drivers to increase current
- Low voltage overhead of 1.4V
- High current accuracy at supply voltage variation
- No EMI
- High power dissipation of 750mW
- Reduced output current at higher temperatures - Negative thermal coefficient of $-0.2\% / K$
- RoHS compliant (pb-free) small and robust SC-74 package
- Qualified according to AEC Q101

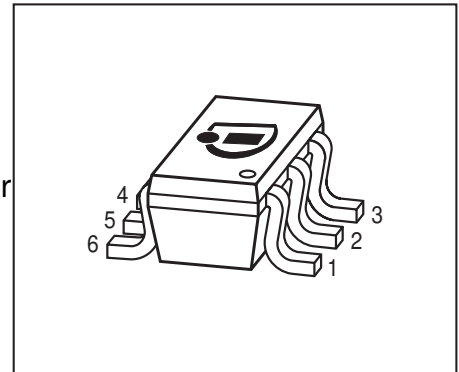

Applications

- Channel letters for advertising, LED strips for decorative lighting
- Aircraft, train, ship illumination
- Retrofits for general lighting, white goods like refrigerator lighting
- Medical lighting
- Automotive applications like CHMSL and rear combination lights

General Description

The BCR405U is a cost efficient LED driver to drive low power LED's. The advantages towards resistor biasing are:

- homogenous light output despite varying forward voltages in different LED strings
- homogenous light output of LED's despite voltage drop across long supply lines
- homogenous light output independent from supply voltage variations
- longer lifetime of the LED's due to reduced output current at higher temperatures (negative thermal coefficient)

The advantages towards discrete solutions are:

- lower assembly cost
- smaller form factor
- better quality due to less soldering points
- higher output current accuracy due to pretested LED drivers

Dimming is possible by using an external digital transistor at the ground pin.

The BCR405U can be operated at higher supply voltages by putting LED's between the power supply +VS and the power supply pin of the LED driver. You can find further details in the application note AN097.

The BCR405U is a perfect fit for numerous low power LED applications by combining small form factor with low cost. These LED drivers offer several advantages to resistors like significantly higher current control at very low voltage drop ensuring high lifetime of LED's.

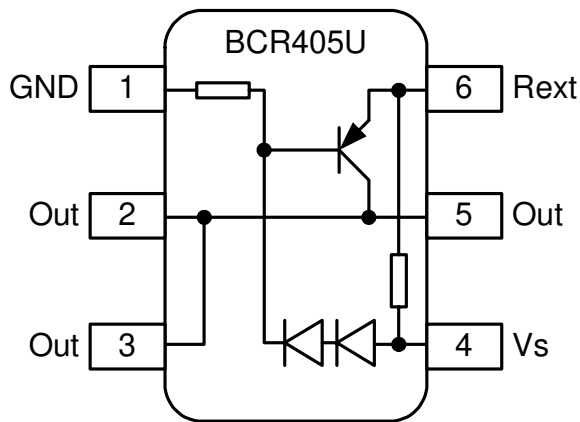
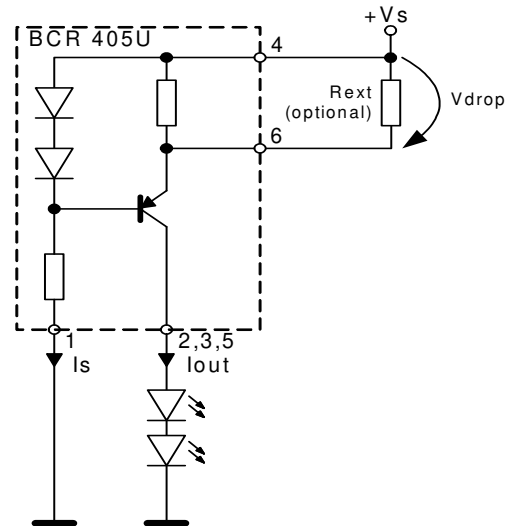
Pin Configuration

Typical Application

Type	Marking	Pin Configuration			Package	
BCR405U	L5s	1 = GND	2;3;5 = I_{out}	4 = V_S	6 = R_{ext}	SC74

Maximum Ratings

Parameter	Symbol	Value	Unit
Supply voltage	V_S	40	V
Output current	I_{out}	65	mA
Output voltage	V_{out}	38	V
Reverse voltage between all terminals	V_R	0.5	
Total power dissipation, $T_S \leq 125\text{ °C}$	P_{tot}	750	mW
Junction temperature	T_j	150	°C
Storage temperature	T_{stg}	-65 ... 150	

Thermal Resistance

Parameter	Symbol	Value	Unit
Junction - soldering point ¹⁾	R_{thJS}	50	K/W

¹⁾For calculation of R_{thJA} please refer to Application Note Thermal Resistance

Electrical Characteristics at $T_A=25^\circ\text{C}$, unless otherwise specified

Parameter	Symbol	Values			Unit
		min.	typ.	max.	
Characteristics					
Collector-emitter breakdown voltage $I_C = 1 \text{ mA}, I_B = 0$	$V_{BR(CEO)}$	40	-	-	V
Supply current $V_S = 10 \text{ V}$	I_S	340	420	500	μA
DC current gain $I_C = 50 \text{ mA}, V_{CE} = 1 \text{ V}$	h_{FE}	100	220	470	-
Internal resistor $I_{Rint} = 50 \text{ mA}$	R_{int}	13	17	22	Ω
Output current $V_S = 10 \text{ V}$	I_{out}	45	50	55	mA
Voltage drop ($V_S - V_E$) $I_{out} = 50 \text{ mA}$	V_{drop}	0.75	0.8	0.85	V

DC Characteristics with stabilized LED load

Lowest sufficient battery voltage overhead $I_{out} > 18\text{mA}$	V_{Smin}	-	1.4	-	V
Output current change versus T_A $V_S = 10 \text{ V}$	$\Delta I_{out}/I_{out}$	-	-0.15	-	%/K
Output current change versus V_S $V_S = 10 \text{ V}$	$\Delta I_{out}/I_{out}$	-	1	-	%/V

Total power dissipation $P_{tot} = f(T_S)$

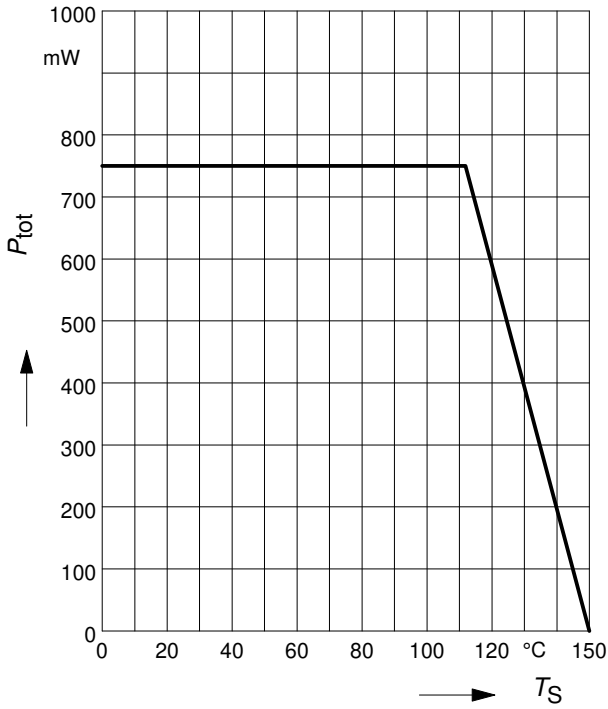

Permissible Pulse Load $R_{thJS} = f(t_p)$

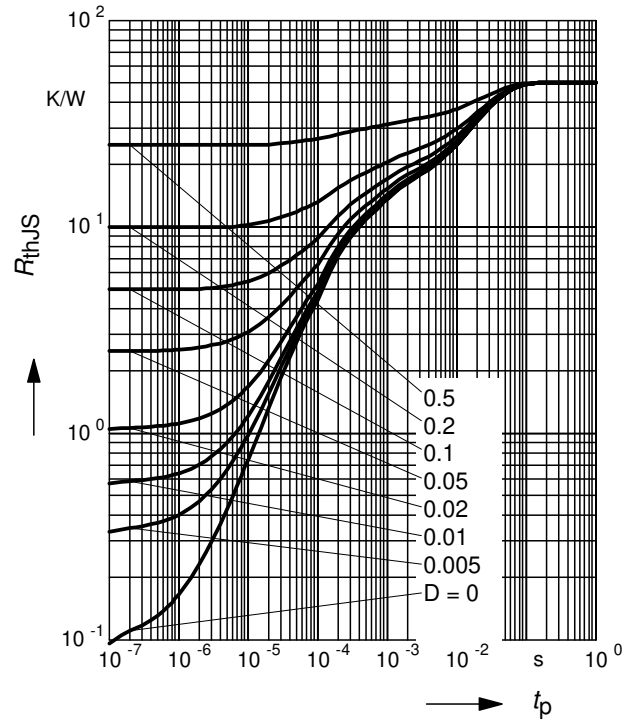

Permissible Pulse Load

$P_{totmax} / P_{totDC} = f(t_p)$

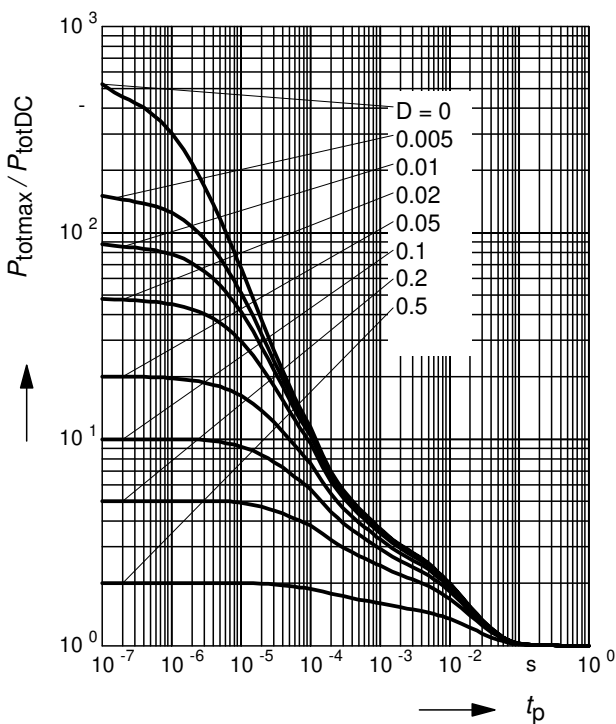

Output current versus supply voltage

$I_{out} = f(V_S); R_{ext} = \text{Parameter}$

$V_S - V_{out} = 1.4 \text{ V}$

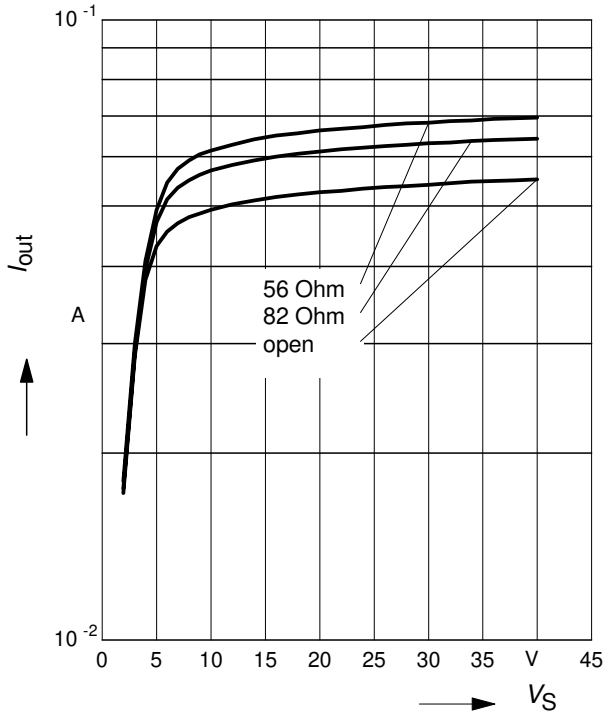

Supply current versus supply voltage

$I_S = f(V_S)$

$T_A = \text{Parameter}$

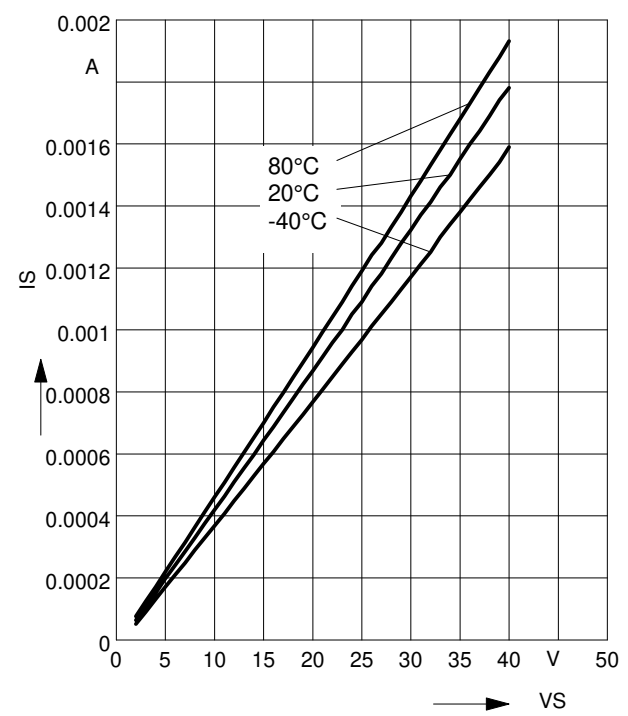

Output current versus supply voltage

$I_{out} = f(V_S), T_A = 20^\circ\text{C}$

$V_S - V_{out}$ as Parameter

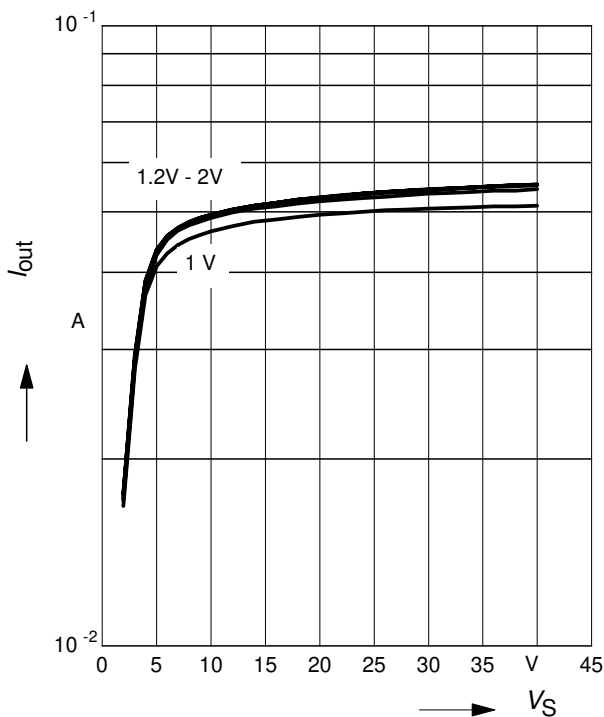

Output current versus supply voltage

$I_{out} = f(V_S), V_S - V_{out} = 1.4 \text{ V}$

$T_A = \text{Parameter}$

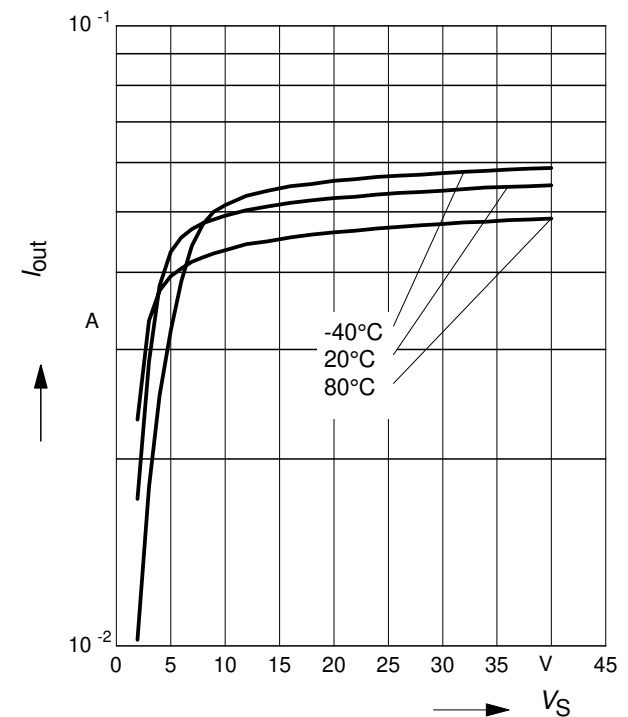

Output current versus external resistor

$I_{out} = (R_{ext}), V_S = 10V, V_S - V_{out} = 1.4 V$
 $T_A = \text{Parameter}$

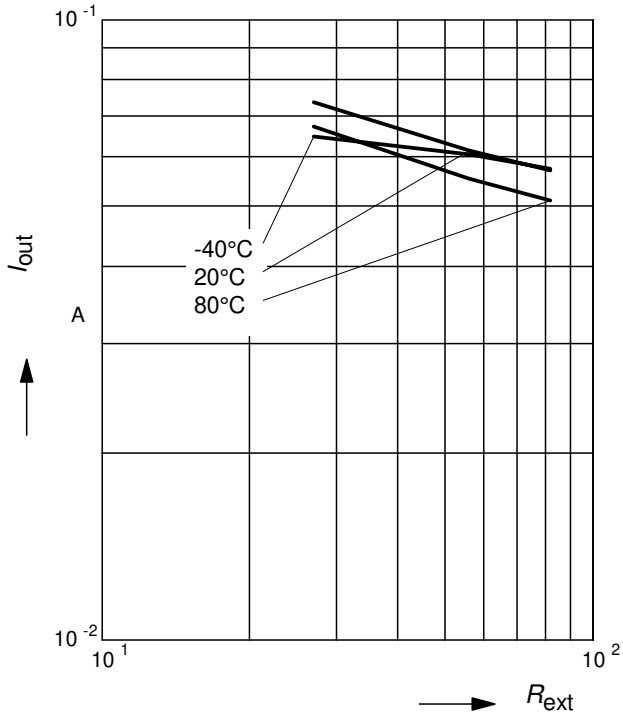

Output current

$I_{out}(T_S), V_S = 10V, V_S - V_{out} = 1.4 V$
 $R_{EXT} = \text{Parameter}$

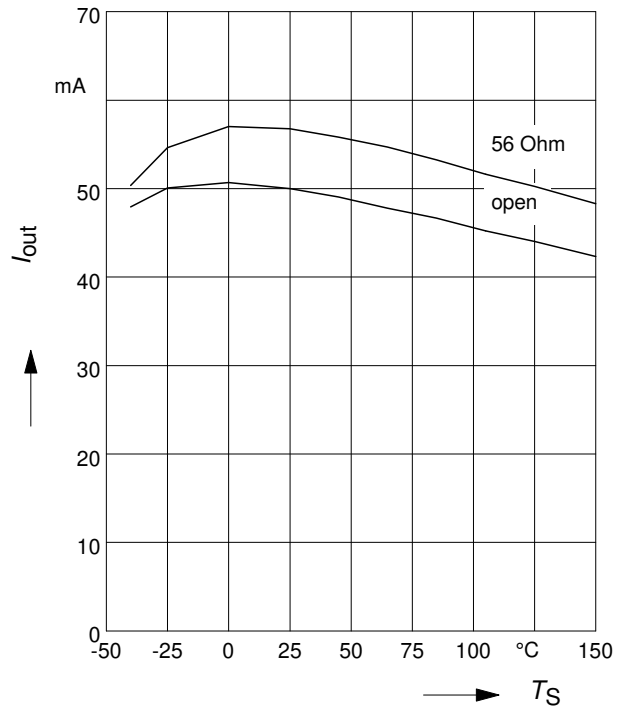

Reference Voltage (Vdrop)

versus $I_{out} = 10 \mu A \dots 10 mA$

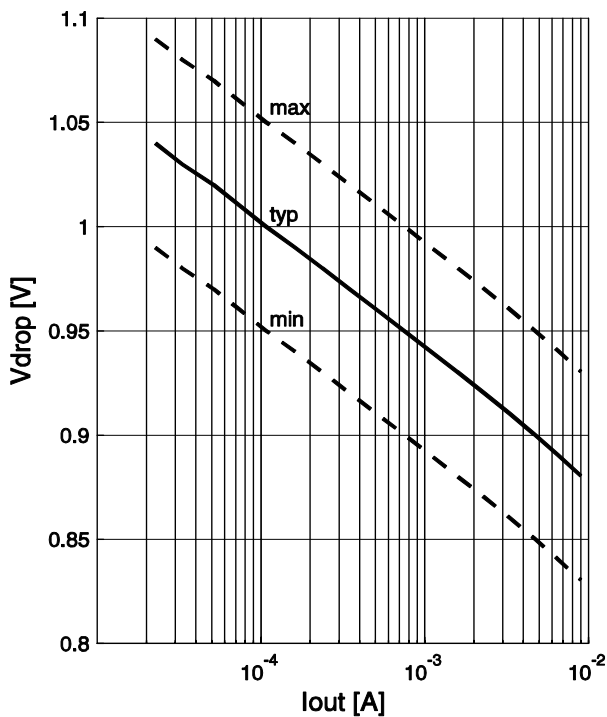

Reference Voltage (Vdrop)

versus $I_{out} = 10 mA \dots 65 mA$

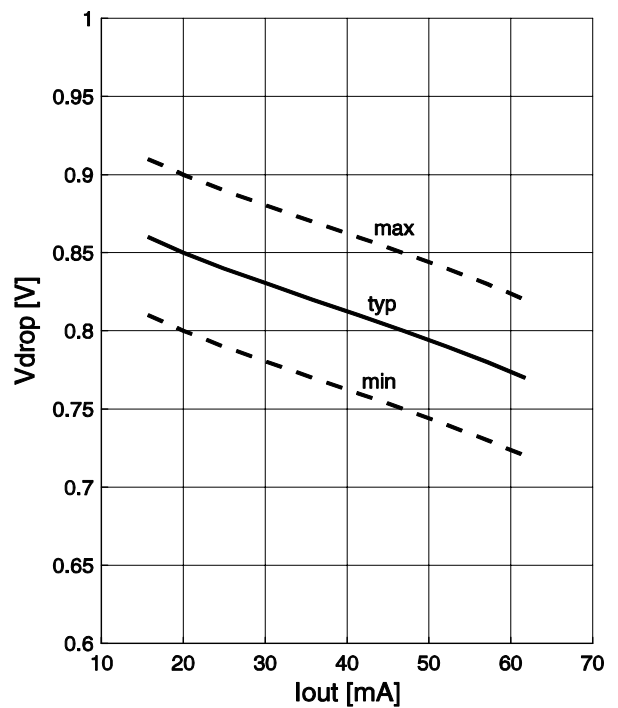

Application circuit:

Stand alone current source

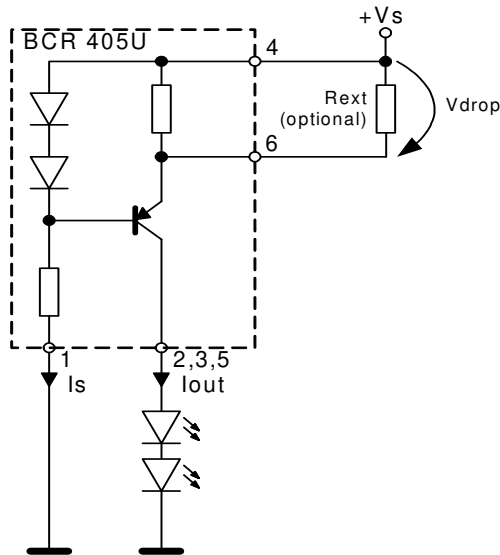
Application circuit:

Boost mode current source with external power transistor

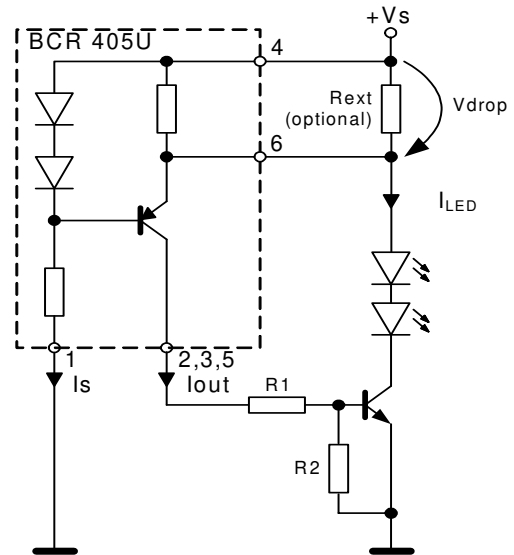
Application hints

BCR405U serves as an easy to use constant current source for LEDs. In stand alone application an external resistor can be connected to adjust the current from 50 mA to 65 mA. Rext can be determined by using the diagram 'Output current versus external resistor', or by referring to diagram 'Reference voltage versus output current'. Look for your desired output current on the x axis and read out the corresponding Vdrop. Calculate Rext:

$$R_{ext} = V_{drop} / (I_{out} - (V_{drop}/R_{int}))$$

Please take into account that the resulting output currents will be slightly lower due to the self heating of the component and the negative thermal coefficient.

In boost mode configuration the LED current can be extended to drive high power LEDs. Select the power transistor according the power dissipation and output current requirements. (e.g. BC817SU or BCX68-25, etc.) Dimension R2 to reduce the transistor current transfer ratio to 20 ... 50. For $I_{LED} / I_{out} = 50$ e.g. $I_{LED} = 350$ mA, I_{out} is 7 mA.

$$R_2 = V_{beON} / I_{out}$$

Dimension R1 for minimum supply voltage condition:

$$R_1 = (V_{smin} - 1.4V - V_{beON}) / I_{out}$$

Please visit our web site for application notes: www.infineon.com/lowcostleddriver

- AN077 gives hints to thermal design
- AN097 helps in case of high supply voltages
- AN101 gives an overview to LED biasing

Package Outline

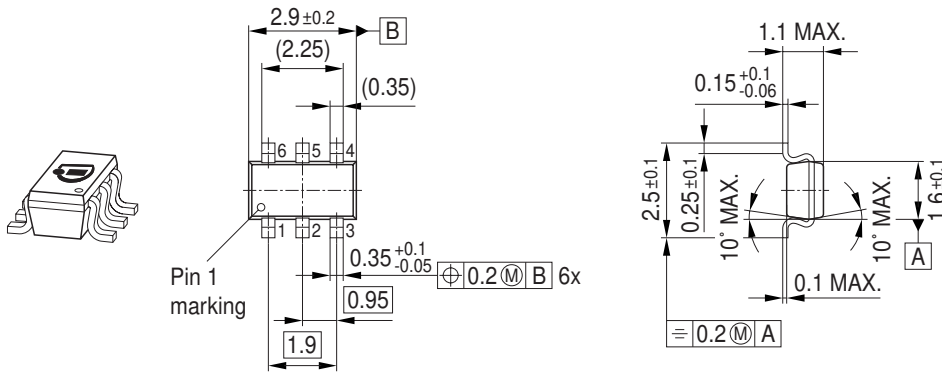

Foot Print

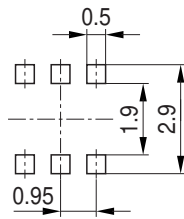

Marking Layout (Example)

Small variations in positioning of Date code, Type code and Manufacture are possible.

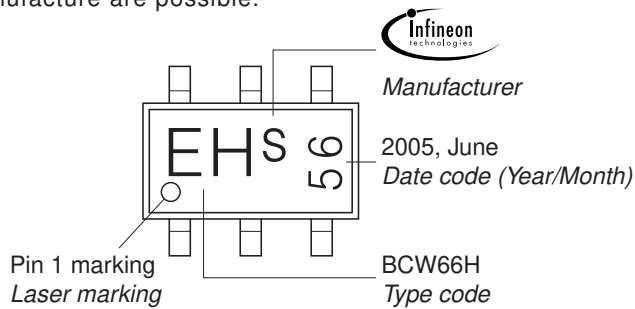

Standard Packing

Reel \varnothing 180 mm = 3.000 Pieces/Reel

Reel \varnothing 330 mm = 10.000 Pieces/Reel

For symmetric types no defined Pin 1 orientation in reel.

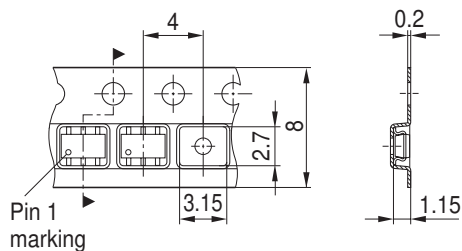

Published by
Infineon Technologies AG
81726 München, Germany
© Infineon Technologies AG 2007.
All Rights Reserved.

Attention please!

The information given in this data sheet shall in no event be regarded as a guarantee of conditions or characteristics ("Beschaffenheitsgarantie"). With respect to any examples or hints given herein, any typical values stated herein and/or any information regarding the application of the device, Infineon Technologies hereby disclaims any and all warranties and liabilities of any kind, including without limitation warranties of non-infringement of intellectual property rights of any third party.

Information

For further information on technology, delivery terms and conditions and prices please contact your nearest Infineon Technologies Office (www.infineon.com).

Warnings

Due to technical requirements components may contain dangerous substances. For information on the types in question please contact your nearest Infineon Technologies Office.

Infineon Technologies Components may only be used in life-support devices or systems with the express written approval of Infineon Technologies, if a failure of such components can reasonably be expected to cause the failure of that life-support device or system, or to affect the safety or effectiveness of that device or system.

Life support devices or systems are intended to be implanted in the human body, or to support and/or maintain and sustain and/or protect human life. If they fail, it is reasonable to assume that the health of the user or other persons may be endangered.