



Chipsmall Limited consists of a professional team with an average of over 10 year of expertise in the distribution of electronic components. Based in Hongkong, we have already established firm and mutual-benefit business relationships with customers from,Europe,America and south Asia,supplying obsolete and hard-to-find components to meet their specific needs.

With the principle of "Quality Parts,Customers Priority,Honest Operation,and Considerate Service",our business mainly focus on the distribution of electronic components. Line cards we deal with include Microchip,ALPS,ROHM,Xilinx,Pulse,ON,Everlight and Freescale. Main products comprise IC,Modules,Potentiometer,IC Socket,Relay,Connector.Our parts cover such applications as commercial,industrial, and automotives areas.

We are looking forward to setting up business relationship with you and hope to provide you with the best service and solution. Let us make a better world for our industry!



## Contact us

Tel: +86-755-8981 8866 Fax: +86-755-8427 6832

Email & Skype: info@chipsmall.com Web: www.chipsmall.com

Address: A1208, Overseas Decoration Building, #122 Zhenhua RD., Futian, Shenzhen, China



# LED Driver IC BCR450

Power Management and  
Multimarket



Never stop thinking

**Edition 2013-02-21**

**Published by Infineon Technologies AG,  
81726 München, Germany**

**© Infineon Technologies AG 2013.  
All Rights Reserved.**

**Attention please!**

The information herein is given to describe certain components and shall not be considered as a guarantee of characteristics.

Terms of delivery and rights to technical change reserved.

We hereby disclaim any and all warranties, including but not limited to warranties of non-infringement, regarding circuits, descriptions and charts stated herein.

**Information**

For further information on technology, delivery terms and conditions and prices please contact your nearest Infineon Technologies Office ([www.infineon.com](http://www.infineon.com)).

**Warnings**

Due to technical requirements components may contain dangerous substances. For information on the types in question please contact your nearest Infineon Technologies Office.

Infineon Technologies Components may only be used in life-support devices or systems with the express written approval of Infineon Technologies, if a failure of such components can reasonably be expected to cause the failure of that life-support device or system, or to affect the safety or effectiveness of that device or system. Life support devices or systems are intended to be implanted in the human body, or to support and/or maintain and sustain and/or protect human life. If they fail, it is reasonable to assume that the health of the user or other persons may be endangered.

BCR450, LED Driver IC

Revision History: 2013-02-21, Rev. 3.1

Previous Version: 2009-10-15, Rev. 3.0

Page	Subjects (major changes since last revision)
Figure 1	Block diagram: Pin 3 (EN), ESD protection and base resistor added
Table 5	Note 1) added to Enable voltage range
Table 6	Typical input capacitance of pin 3 (EN) added
Figure 5	Units added to figure title
Figure 6	Units added to figure title

## 1 BCR450 Power LED Driver IC

### Features

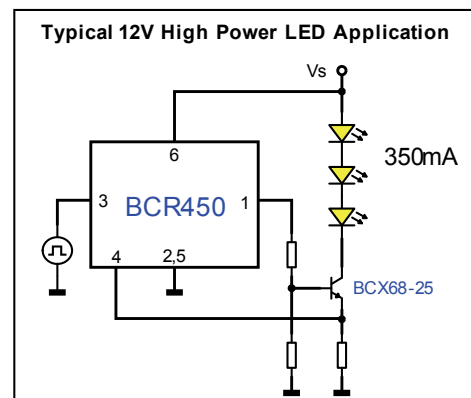
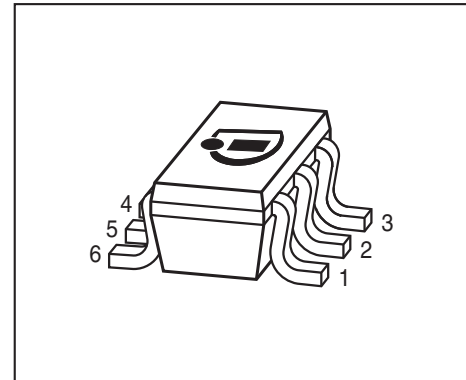
- Low voltage drop across sense resistor, 0.15 V typical
- High output current precision
- Operating voltage from 8 to 27 V
- Over voltage protection
- Overtemperature current foldback and Thermal shut down function
- Adjustable Constant LED Current up to 85 mA in stand alone operation
- Precise Internal bandgap enables High output current accuracy
- Up to 2.5 A LED current possible by using external transistor
- EN Input for PWM LED brightness control and On/Off control
- Very Low Standby Current
- Minimum number of external components required, no inductors
- Very small SC-74 package: 2.9 mm x 2.5 mm x 1.1 mm

### Benefits

- High level of colour control due to high output current precision
- Small space requirement
- No electro- magnetic interference
- Active thermal monitoring of chip and LED temperature with current fold- back to avoid thermal overstress
- Low cost device
- Scalable output stage optimizing cost and space

### Typical Applications

- General lighting e.g. retrofits
- Architectural lighting, Medical and Dental lighting
- Transportation like train and aircraft lighting
- Strobe lighting
- Universal constant current source
- Signal and marker lights for orientation or navigation
- LED controller for industrial applications, not qualified to AECQ-100



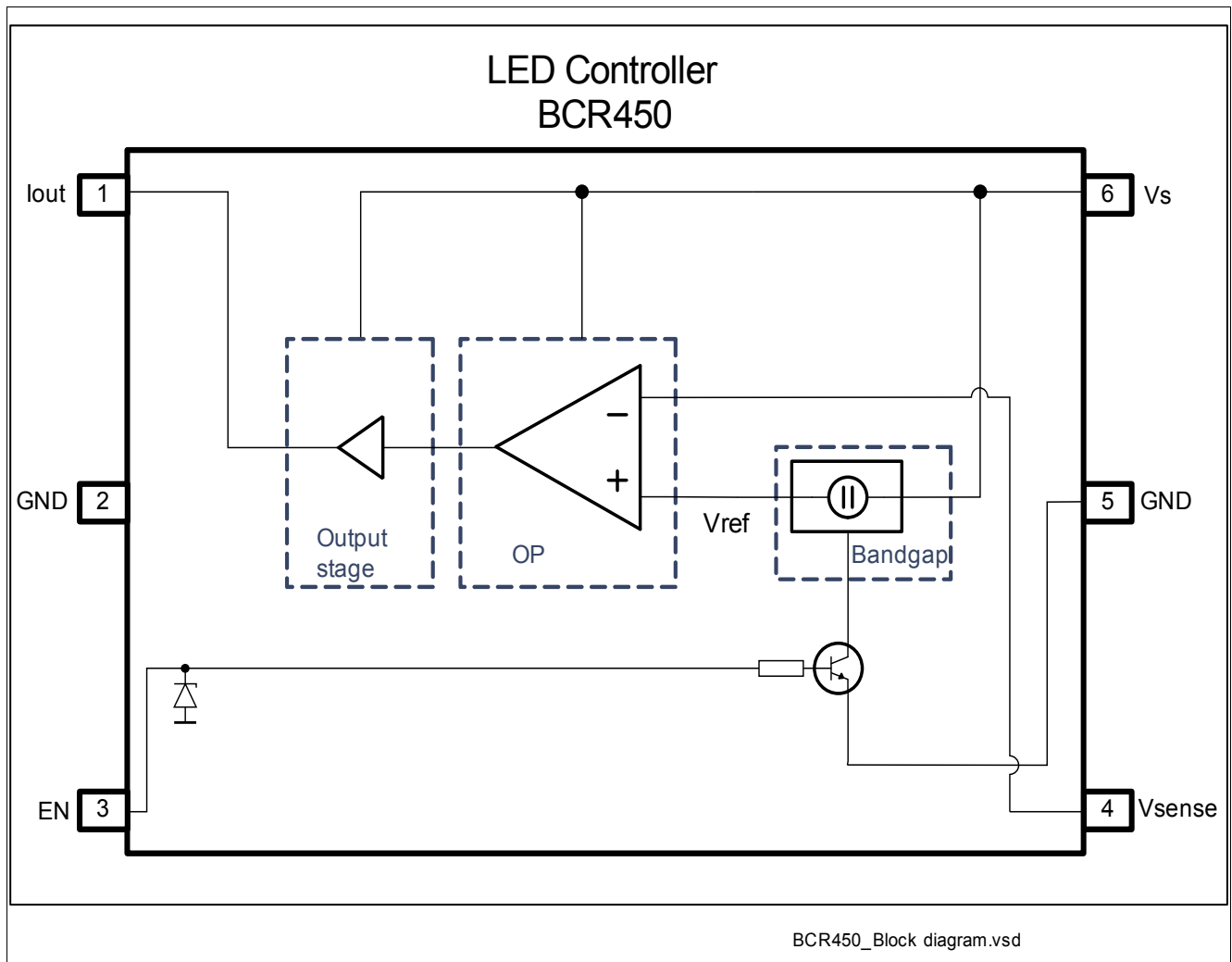
## 2 Description

The BCR450 is a LED driver IC optimized for usage with an external power transistor for driving LEDs above 100 mA. For currents up to 85 mA the BCR450 can be used in stand alone operation. The output current level can be adjusted with an external sense resistor.

The IC can be switched on and off by an external signal, which is also suitable to regulate brightness of the LEDs by PWM dimming.

The precise internal bandgap stabilizes the circuit and provides stable current conditions over temperature range. Additional features are included to protect the LEDs from overload, short circuit events as well as from over voltage. The LEDs can be also protected against thermal overload by thermally coupling the LEDs to the BCR450.





**Figure 1** Block diagram

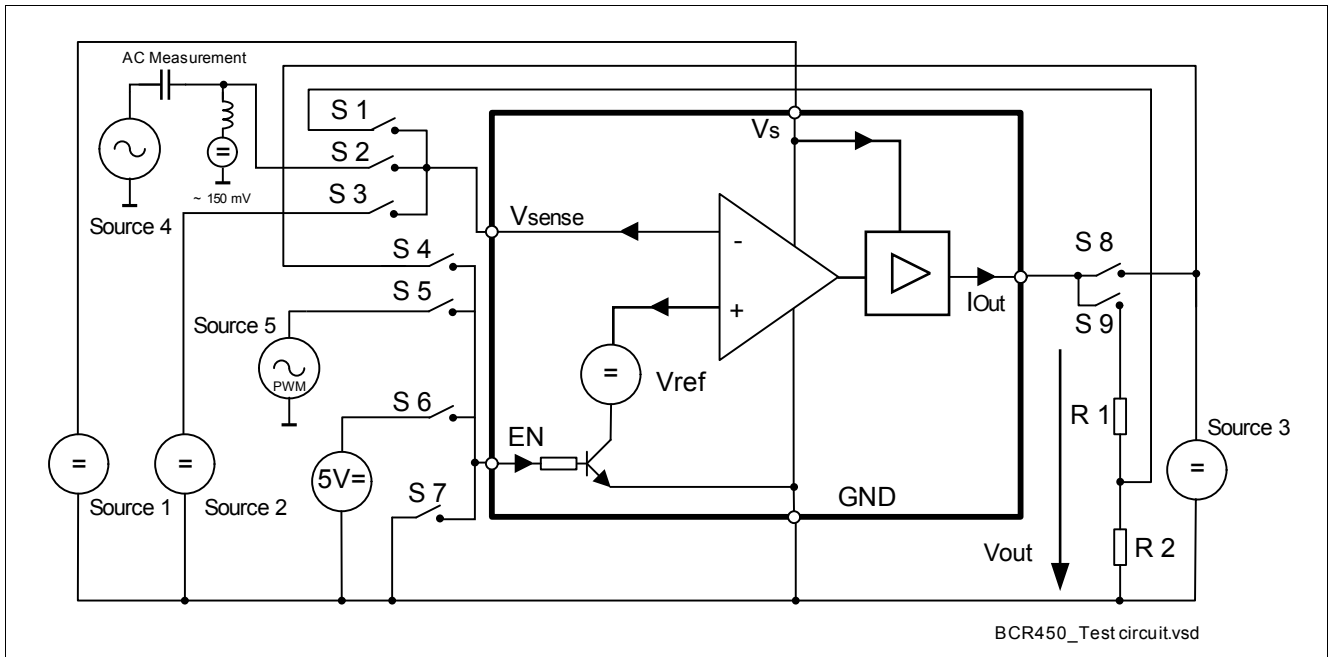
**Pin Definition**

**Table 1** Pin definition and function

Pin number	Pin Symbol	Function
1	$I_{out}$	Controlled output current to drive LEDs
2	GND	IC ground
3	EN	Power On control voltage pin ( <i>PWM input</i> )
4	$V_{sense}$	Sense control voltage pin for internal feedback mechanism
5	GND	IC ground
6	$V_s$	Supply voltage

**Table 2** Marking

Type	Marking	Package
BCR450	50s	SC74


**Figure 2 Electrical test circuit**
**Thermal resistance**
**Table 3 Thermal resistance**

Parameter	Symbol	Value	Unit
Junction - solder point	$R_{thJS}$	75	K/W

**Absolute Maximum Ratings**
**Table 4 Absolute Maximum ratings**

Parameter	Symbol	Limit Value	Unit
Supply voltage	$V_s$	40	V
Sense Voltage	$V_{sense}$	200	mV
Output current	$I_{out}$	100	mA
Total Power Dissipation; $T_s = 112.5^\circ\text{C}$	$P_{tot}$	500	mW
Junction temperature	$T_J$	150	$^\circ\text{C}$
Storage temperature range	$T_{STG}$	-65... 150	$^\circ\text{C}$
ESD capability Human Body Model <sup>1)</sup>	$V_{ESD\_HBM}$	2000	V

1) For ESD testing, the chip was mounted in a SC74 package on an application board, where GND is electrically connected to the chip GND

### 3 Electrical Characteristics

#### 3.1 DC Characteristics

$8\text{ V} < V_S < 27\text{ V}$ ;  $-40\text{ }^\circ\text{C} < T_J < 150\text{ }^\circ\text{C}$ , all voltages with respect to ground; current directions as given in [Figure 2](#); unless otherwise specified

All parameters are tested at  $25\text{ }^\circ\text{C}$ , unless otherwise specified

**Table 5 DC Characteristics**

Parameter	Symbol	Values			Unit	Note / Test Condition
		Min.	Typ.	Max.		
Overall current consumption	$I_{S_{\text{short}}}$	70	90		mA	$I_S$ short; $V_S = 8..27\text{ V}$ $V_{\text{sense}} = 20\text{ mV}$
Overall current consumption	$I_{S_{\text{short}}}$			600	$\mu\text{A}$	$I_S$ short; $V_S = 42\text{ V}$ $V_{\text{sense}} = 20\text{ mV}$
Overall standby current consumption	$I_{S_{\text{standby}}}$			200	nA	EN = 0 V; $V_S = 8..27\text{ V}$ $V_{\text{sense}} = 20\text{ mV}$
Current of enable input	$I_{\text{EN}}$	20	40	70	$\mu\text{A}$	$V_{\text{sense}} = 0..200\text{ mV}$
Current of driver output	$I_{\text{outhigh}}$	70	90		mA	$V_{\text{sense}} = 20\text{ mV}$ ; $V_S = 8\text{ V}$
Current of driver output	$I_{\text{outlow}}$			100	nA	$V_{\text{sense}} = 200\text{ mV}$ ; $V_S = 8\text{ V}$
Current of Sense input	$I_{\text{sense}}$			200	nA	$V_{\text{sense}} = 20..200\text{ mV}$
Voltage of Driver output	$V_{\text{out}}$		6		V	$I_{\text{out}} = 15\text{ mA}$ ; S1, S6, S8, S9 = on; R1 = 390 $\Omega$ ; R2 = 10 $\Omega$ ; see <a href="#">Figure 2</a>
Voltage of Sense input	$V_{\text{sense}}$	135	150	165	mV	$I_{\text{out}} = 15\text{ mA}$ ; $V_S = 8..27\text{ V}$ S3, S6, S8 = on; R1 = 390 $\Omega$ ; R2 = 10 $\Omega$ $T_J = 115\text{ }^\circ\text{C}$ see <a href="#">Figure 2</a>
Enable voltage range	$U_{\text{Pon}}$	-0.3		5 <sup>1)</sup>	V	
Control voltage for power on	$U_{\text{On}}$	0.6	0.85	5	V	
Control voltage for power off	$U_{\text{Off}}$	-0.3		0.35	V	
Over voltage Protection	$V_{s, \text{OV}}$	27			V	$I_{\text{out}} \rightarrow 0\text{ A}$
Delta sense voltage	$\Delta V_{\text{sense}}$	2	10	50	mV	$I_{\text{out}}: 0 \rightarrow 50\text{ mA}$
Drop Voltage	$V_S - V_{\text{out}}$		1.2		V	$I_{\text{out}} < 40\text{ mA}$
Temperature shut down	$T_{\text{SD}}$	130	150	170	$^\circ\text{C}$	$I_{\text{out}} \rightarrow 0\text{ A}$ ; refer to $T_J$

1) ESD protection diode of pin 3 (EN) will breakdown above 5 V input voltage to GND



### 3.2 Digital Signals

All parameters are tested at 25 °C, unless otherwise specified

**Table 6 Digital Control Parameter (EN)**

Parameter	Symbol	Values			Unit	Note / Test Condition
		Min.	Typ.	Max.		
PWM signal frequency	$f_{\text{PWM}}$			1000	Hz	$t_{\text{duty cycle}} = 1\%$ ; signal level reaches 100% in on and off mode
PWM Duty cycle	$t_{\text{duty PWM}}$	5			%	$F = 5 \text{ kHz}$ ; signal level reaches 100% in on and off mode
PWM voltage	$U_{\text{PWM}}$			5	V	
EN input capacitance to GND	$C_{\text{EN}}$		130		pF	EN = 0 V

### 3.3 Transient Parameters

$8 \text{ V} < V_{\text{S}} < 27 \text{ V}$ ;  $-40 \text{ °C} < T_{\text{J}} < 150 \text{ °C}$ , all voltages with respect to ground; current directions as given in [Figure 2](#); unless otherwise specified

All parameters are tested at 25 °C, unless otherwise specified

**Table 7 Digital Control Parameter (EN)**

Parameter	Symbol	Values			Unit	Note / Test Condition
		Min.	Typ.	Max.		
Response Time	$T_{\text{ON}}$			10	$\mu\text{s}$	EN: 0 -> 5 V @ $t_{\text{rise}} < 20 \text{ ns}$ $t_{\text{risetime}} @ (10\text{...}90\%) * V_{\text{sense}}$ ( $I_{\text{out}} \sim 15 \text{ mA}$ ); $R_{\text{sense}} = 10 \Omega$
	$T_{\text{OFF}}$			70	$\mu\text{s}$	EN: 5 V -> 0 @ $t_{\text{fall}} < 20 \text{ ns}$ $t_{\text{falltime}} @ (90\text{...}10\%) * V_{\text{sense}}$ ( $I_{\text{out}} \sim 15 \text{ mA}$ ); $R_{\text{sense}} = 10 \Omega$

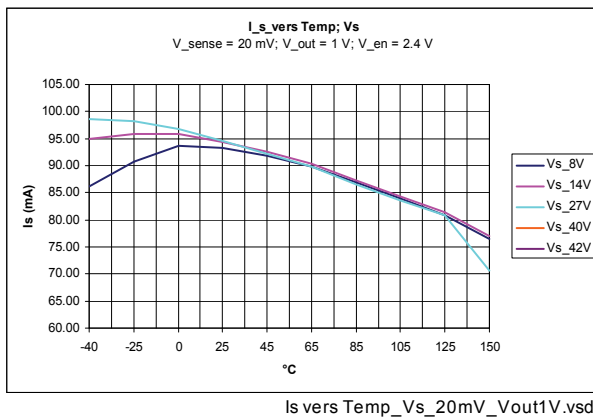
## 4 Measured Parameters

BCR450 IC has been measured in test bench with undefined high thermal resistance  
This is valid for all diagramed DC- and AC- Parameters

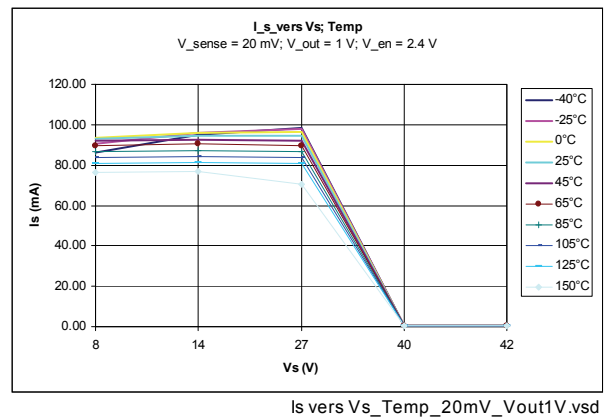
### 4.1 DC- Parameter

$$V_{out} = 1.0 \text{ V, EN} = 2.4 \text{ V}$$

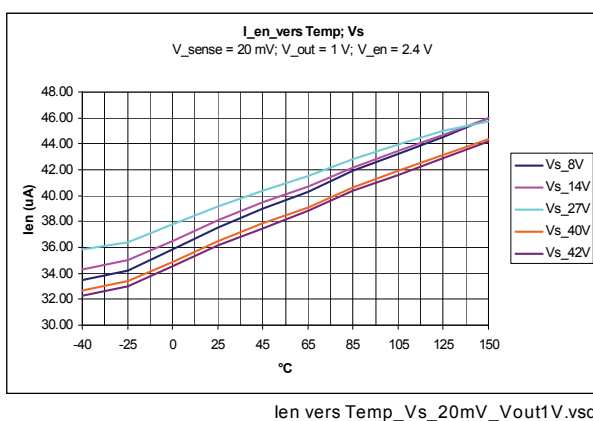
$I_S$  vers Temperature ( $V_S$ );  $V_{sense} = 20 \text{ mV}$



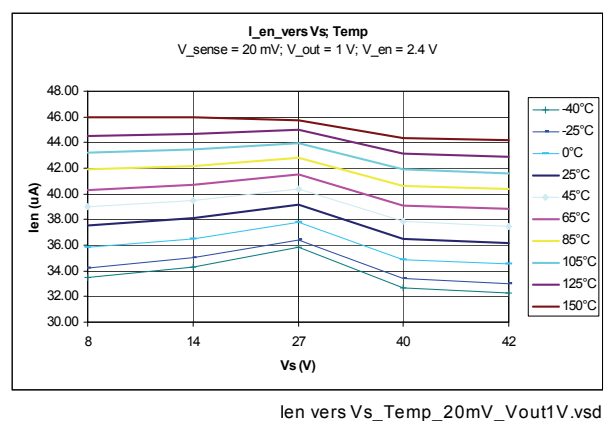
$I_S$  vers  $V_S$  (Temperature);  $V_{sense} = 20 \text{ mV}$



$I_{en}$  vers Temperature ( $V_S$ );  $V_{sense} = 20 \text{ mV}$

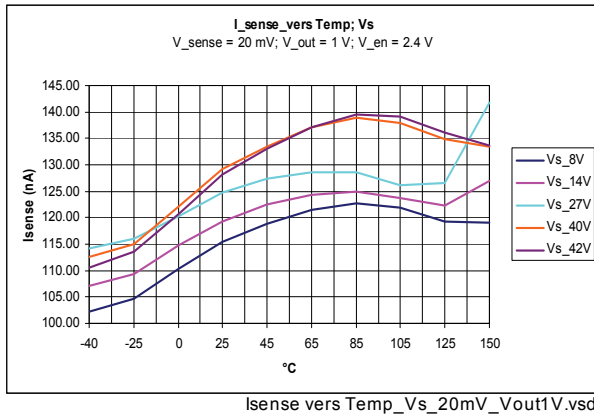


$I_{en}$  vers  $V_S$  (Temperature);  $V_{sense} = 20 \text{ mV}$

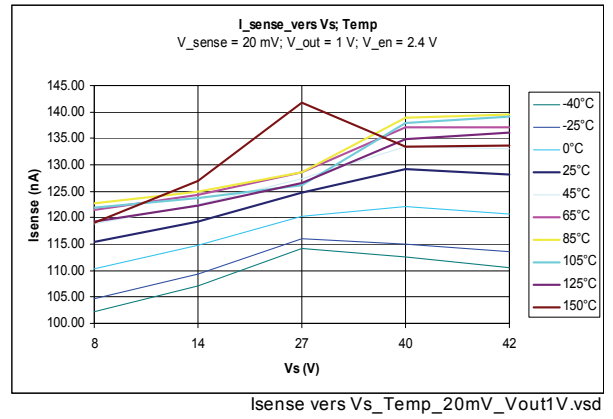


**Measured Parameters**

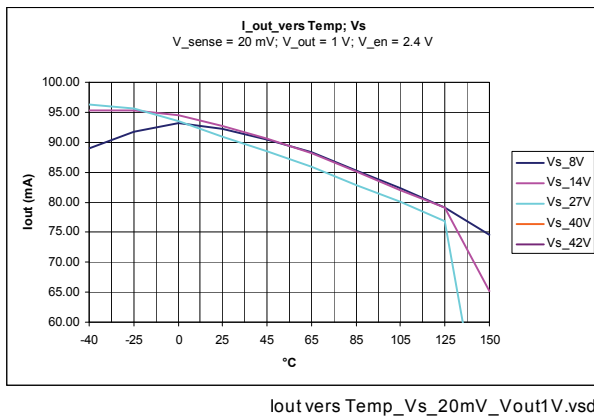
$I_{sense}$  vers Temperature ( $V_s$ );  $V_{sense} = 20$  mV



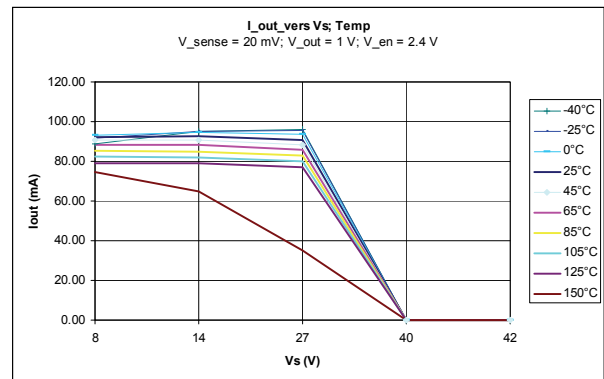
$I_{sense}$  vers  $V_s$  (Temperature);  $V_{sense} = 20$  mV



$I_{out}$  vers Temperature ( $V_s$ );  $V_{sense} = 20$  mV

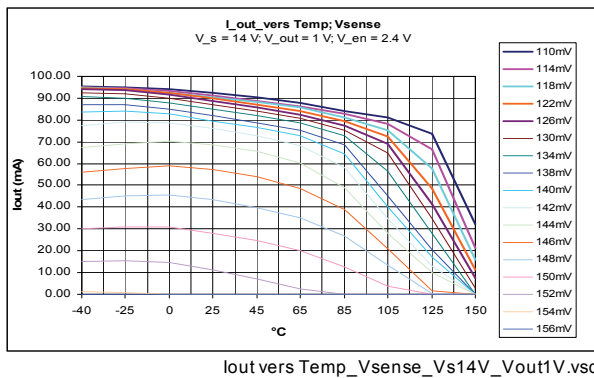


$I_{out}$  vers  $V_s$  (Temperature);  $V_{sense} = 20$  mV

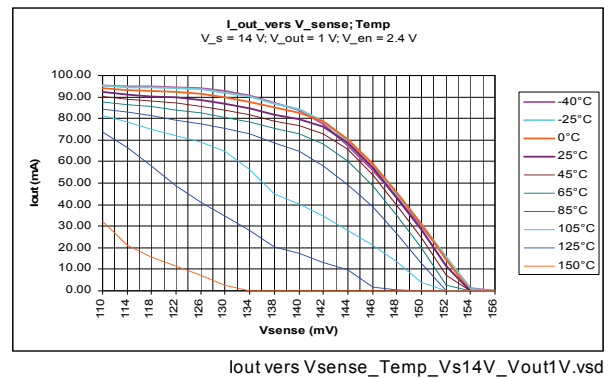


$V_s = 14$  V,  $V_{out} = 1$  V;  $EN = 2.4$  V

$I_{out}$  vers Temperature ( $V_{sense}$ )

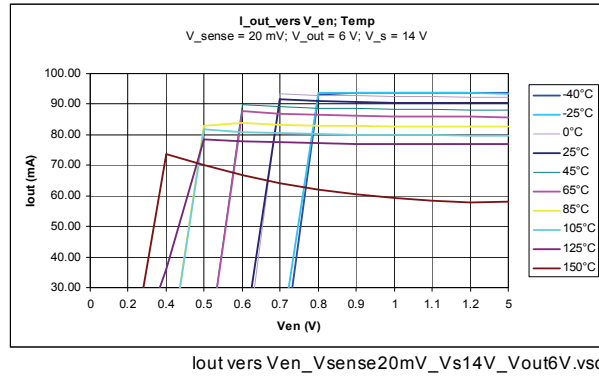


$I_{out}$  vers  $V_{sense}$  (Temperature)



$V_s = 14\text{ V}$ ,  $V_{out} = 6\text{ V}$ ;  $EN = 20\text{ mV}$

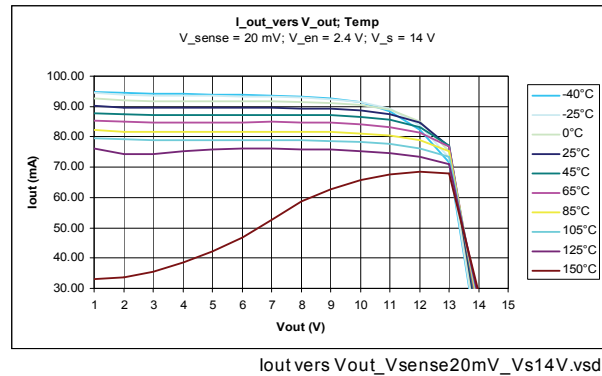
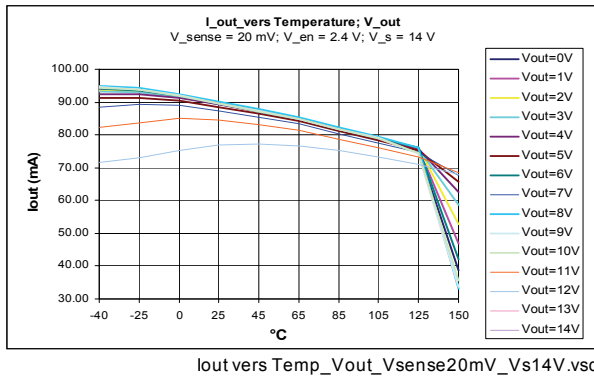
$I_{out}$  vers  $EN$  (Temperature)



$V_s = 14\text{ V}$ ,  $V_{sense} = 20\text{ mV}$ ;  $EN = 2.4\text{ V}$

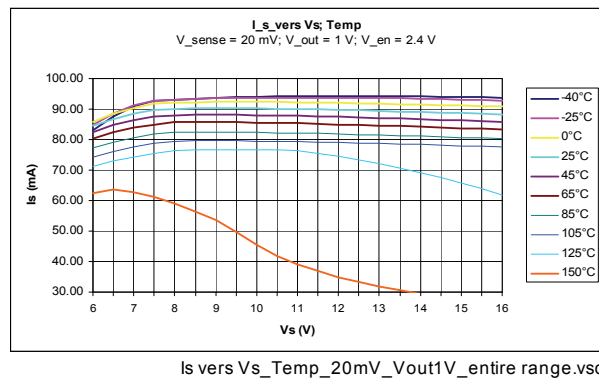
$I_{out}$  vers Temperature ( $V_{out}$ )

$I_{out}$  vers  $V_{out}$  (Temperature)



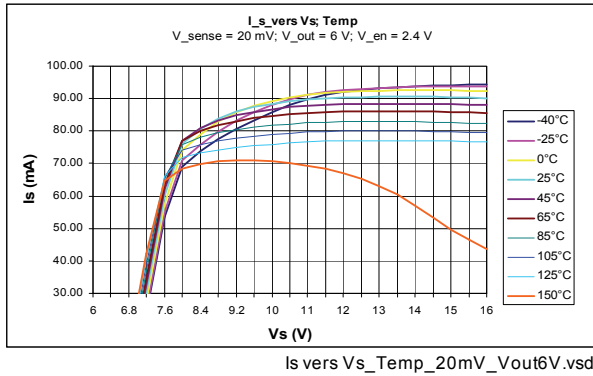
$V_{out} = 1\text{ V}$ ,  $V_{sense} = 20\text{ mV}$ ;  $EN = 2.4\text{ V}$

$I_s$  vers  $V_s$  (Temperature)

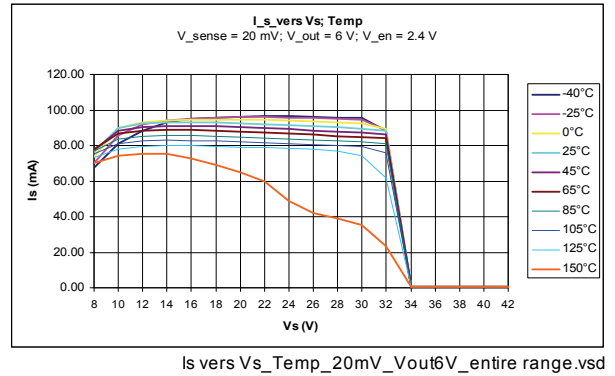


$V_{out} = 6\text{ V}$ ,  $V_{sense} = 20\text{ mV}$ ;  $EN = 2.4\text{ V}$

$I_s$  vers  $V_S$  (Temperature)

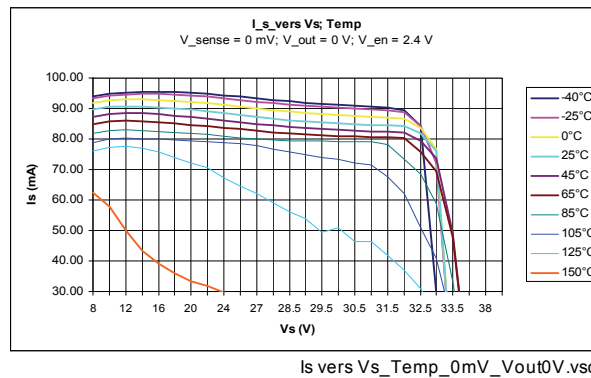


$I_s$  vers  $V_S$  (Temperature)



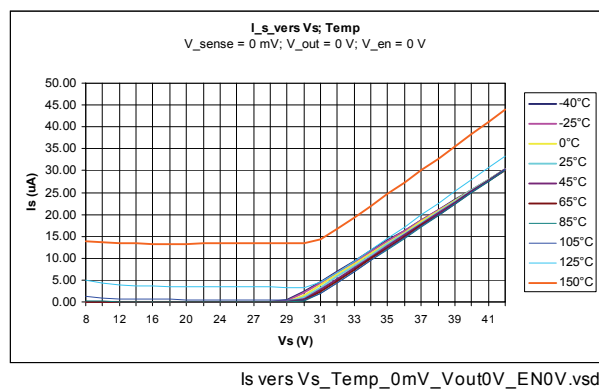
$I_{s\text{ short}} \rightarrow V_{out} = 0\text{ V}$ ,  $V_{sense} = 0\text{ mV}$ ;  $EN = 2.4\text{ V}$

$I_s$  vers  $V_S$  (Temperature)



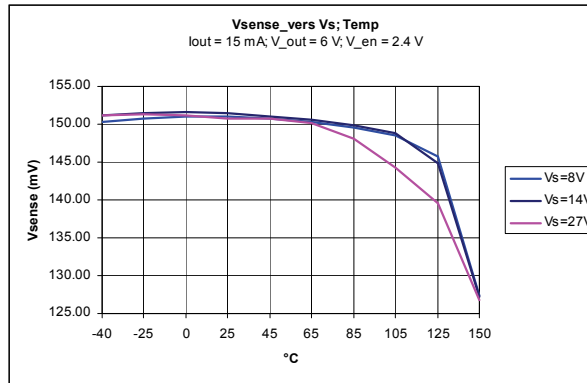
$I_{s\text{ standby}} \rightarrow V_{out} = 0\text{ V}$ ,  $V_{sense} = 0\text{ mV}$ ;  $EN = 0\text{ V}$

$I_s$  vers  $V_S$  (Temperature)



$V_{out} = 6\text{ V}$ ,  $I_{out} = 15\text{ mA}$ ;  $EN = 2.4\text{ V}$

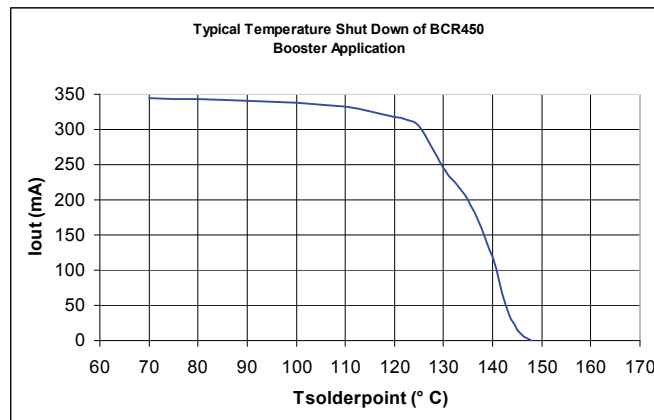
$V_{sense}$  vers  $V_S$  (Temperature)



Vsense vers Vs\_Temp\_Iout15mA\_Vout6V.vsd

$V_S = 12\text{ V}$ ,  $I_{out} = 350\text{ mA}$ , Booster Application, see Figure 3

$I_{out}$  vers  $T_{solder}$

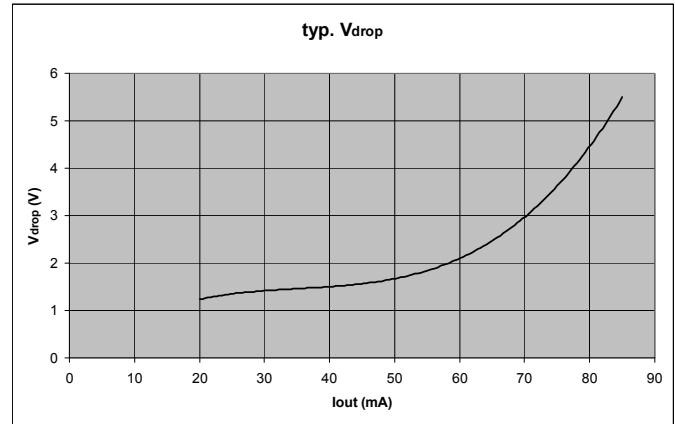
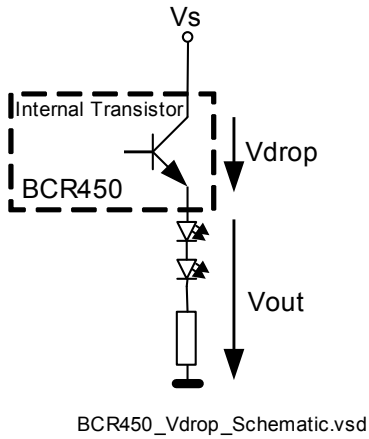


TSD.vsd



**EN = 2.4 V**

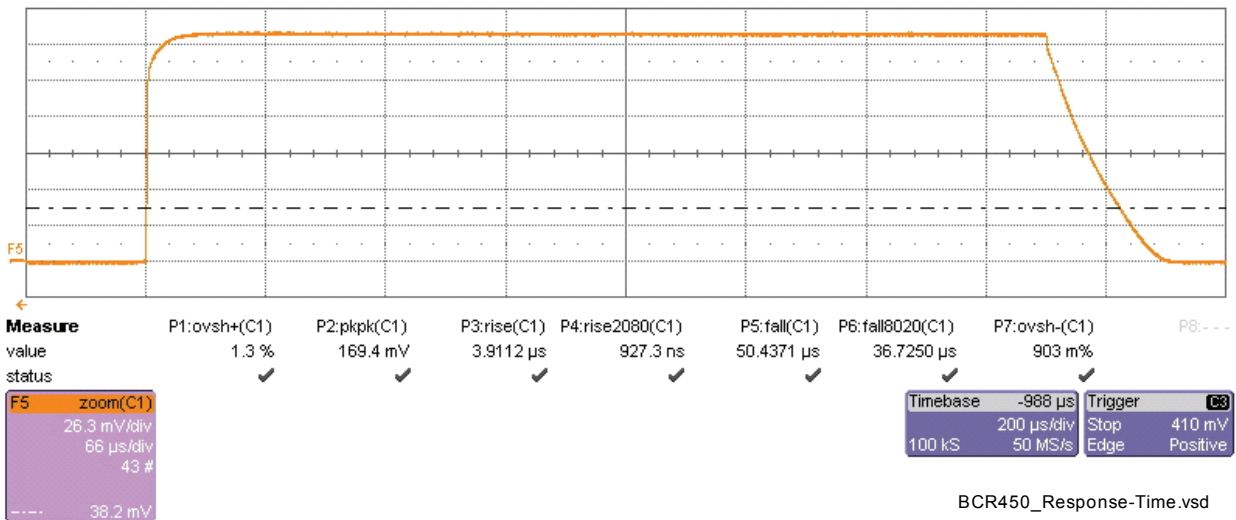
$V_{drop}$  vers  $I_{out}$



## 4.2 AC- Parameter

Response Time

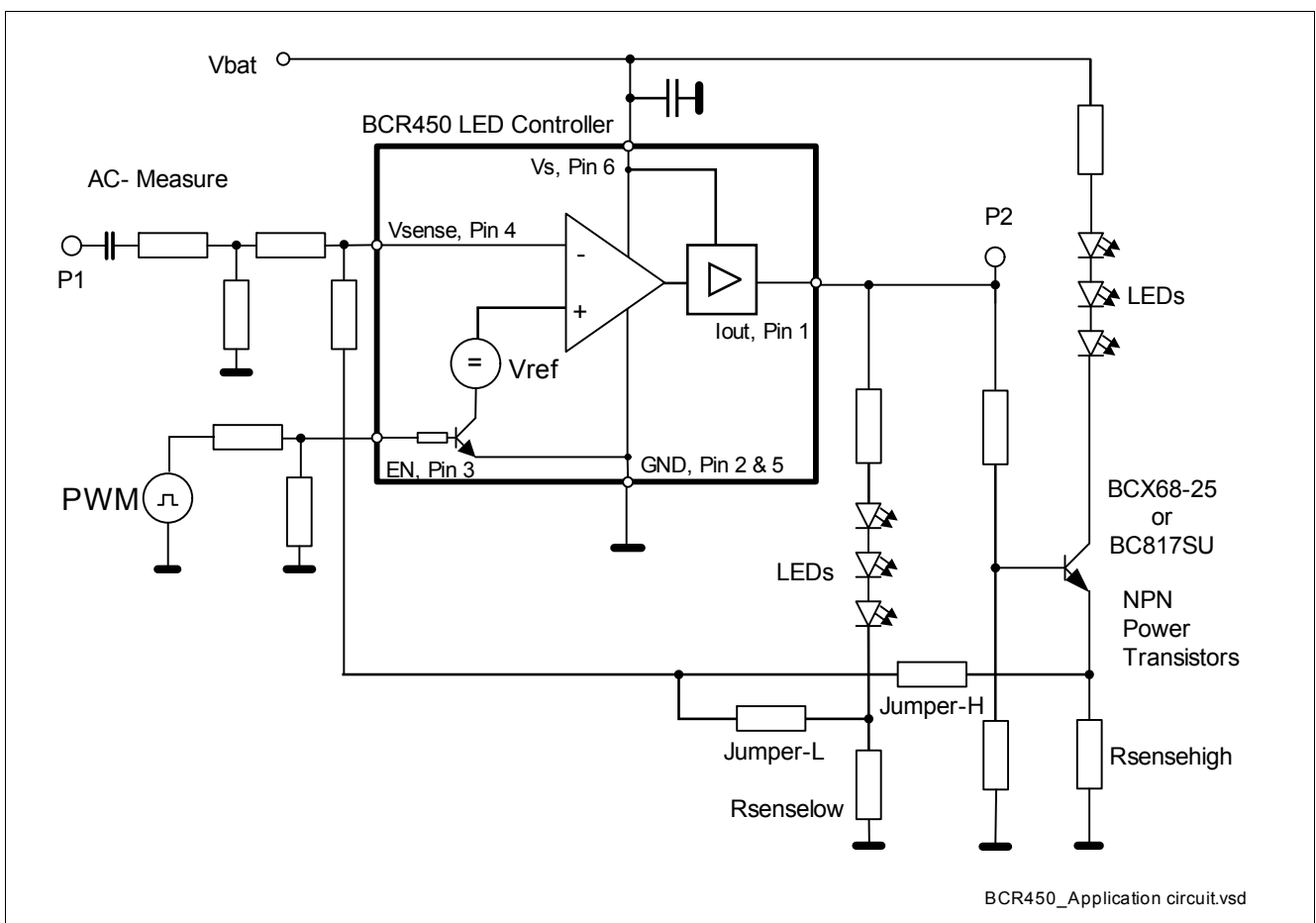
$T_{on}$  &  $T_{off}$ ;  $V_s = 12\text{ V}$ ;  $f_{Pulse} = 1\text{ kHz}$ ;  $t_{duty} = 50\%$



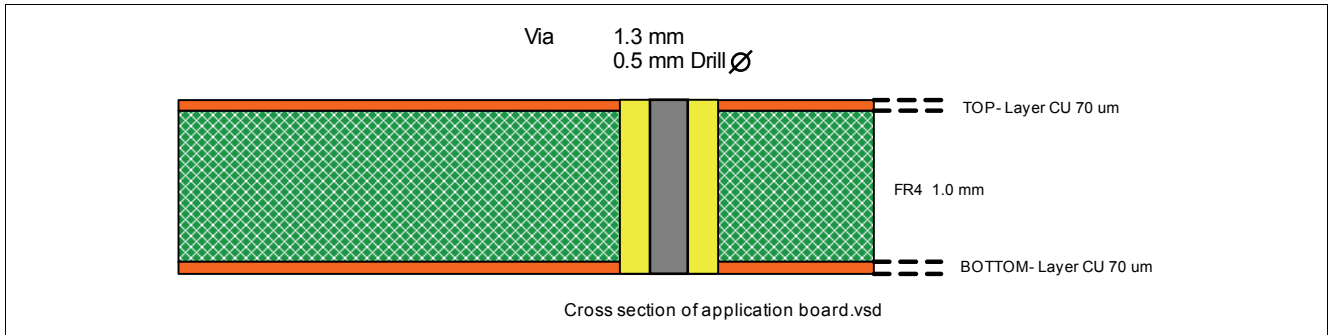
## 5 Evaluation Board

The evaluation board is designed to test the BCR450 as a stand alone device for lower LED current applications and also with additional external “booster” transistors for high current, high brightness LEDs. Up to three external transistors BCX68 or BC817SU each could be used on the PCB to minimize thermal problems.

3 LEDs in series for high current mode or 3 LEDs for low current applications can be chosen by setting resistors (for further application hints see **AN105**). The particular sense voltage can be derived by jumpers which are provided in the layout for each test case. Additional test circuit is included to measure AC characteristics, and the ENABLE input is designed to connect a PWM signal. The PCB is manufactured in double sided FR4 with substrate thickness of 1.0 mm.

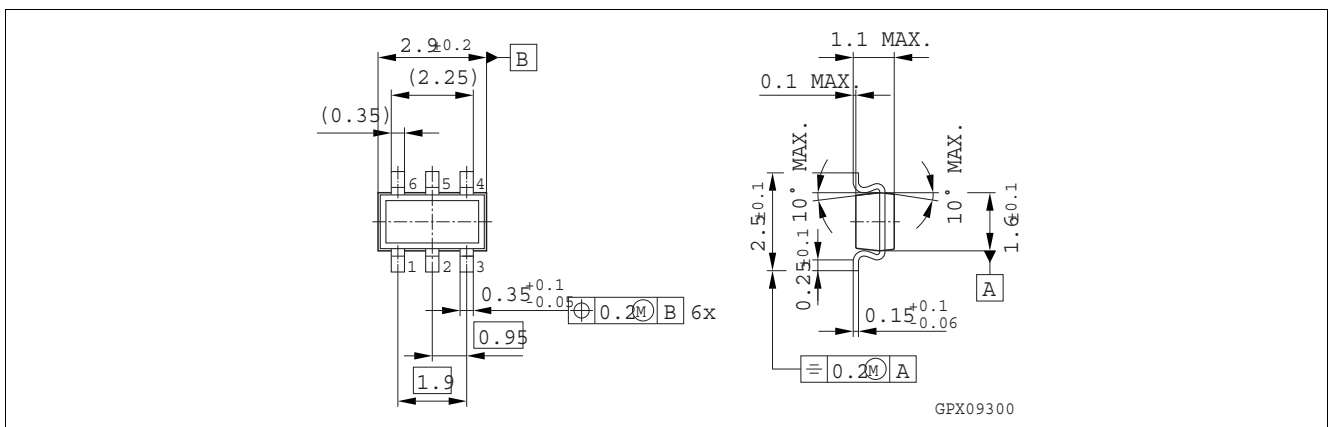


**Figure 3 Evaluation board schematic**

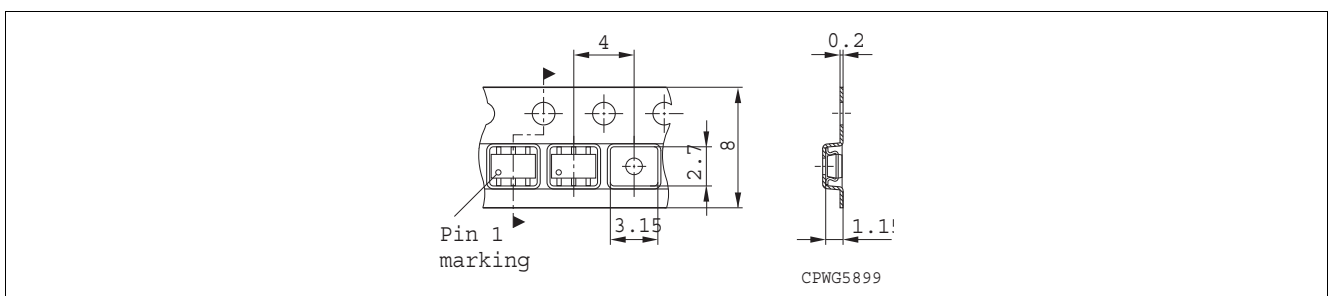


**Figure 4** Cross section of evaluation board

## 6 Package Information



**Figure 5** Package outline; SC74 (dimensions in mm)



**Figure 6** Tape loading (dimensions in mm)