



Chipsmall Limited consists of a professional team with an average of over 10 year of expertise in the distribution of electronic components. Based in Hongkong, we have already established firm and mutual-benefit business relationships with customers from,Europe,America and south Asia,supplying obsolete and hard-to-find components to meet their specific needs.

With the principle of “Quality Parts,Customers Priority,Honest Operation,and Considerate Service”,our business mainly focus on the distribution of electronic components. Line cards we deal with include Microchip,ALPS,ROHM,Xilinx,Pulse,ON,Everlight and Freescale. Main products comprise IC,Modules,Potentiometer,IC Socket,Relay,Connector.Our parts cover such applications as commercial,industrial, and automotives areas.

We are looking forward to setting up business relationship with you and hope to provide you with the best service and solution. Let us make a better world for our industry!



Contact us

Tel: +86-755-8981 8866 Fax: +86-755-8427 6832

Email & Skype: info@chipsmall.com Web: www.chipsmall.com

Address: A1208, Overseas Decoration Building, #122 Zhenhua RD., Futian, Shenzhen, China



LED Drivers for LCD Backlights

Backlight LED Drivers for Small LCD Panels (Charge Pump Type)



BD1604MUV, BD1604MVV

No.11040EBT23

●Description

This LSI is a 4 white LED driver for small LCD backlight. At the charge pump type, the number of external devices is minimized.

●Features

- 1) 4 parallel LED driver is mounted.
- 2) The LED current can be controlled via an external resistance.
- 3) Maximum current is 120mA (30mA × 4).
- 4) LED1 to LED4 can be turned on or off via an external control pin.
- 5) The relative current accuracy among LEDs (LED1 to LED4) is 3%.
- 6) Automatically transition to each mode (×1.0, ×1.5, ×2.0).
- 7) High efficiency (90% or more at maximum) is achieved.
- 8) Various protection functions such as output voltage protection function, current overload limiter and thermal shutdown circuit are mounted.

●Applications

This driver provides for:

- Backlight using white LED
- Auxiliary lights for mobile phone cameras and simplified flash

●Lineup

Parameter	BD1604MUV	BD1604MVV
Number of LED channels	4ch	4ch
Maximum current	120mA	120mA
Package	VQFN016V3030 3.00mm×3.00mm	SQFN016V4040 4.00mm×4.00mm

●Absolute Maximum Rating (Ta=25°C)

Parameter	Symbol	Ratings	Unit
Power supply voltage	Vmax	7	V
Allowable loss	BD1604MUV	Pd	mW
	BD1604MVV		
Operating temperature range	Topr	-30~85	°C
Storage temperature range	Tstr	-55~150	°C

*1 When a glass epoxy substrate (70mm×70mm×1.6mm) has been mounted, this loss will decrease 5.6mW/°C if Ta is higher than or equal to 25°C.

*2 When a glass epoxy substrate (70mm×70mm×1.6mm) has been mounted, this loss will decrease 6.24mW/°C if Ta is higher than or equal to 25°C.

●Recommended Operation Range

Parameter	Symbol	Limits	Unit	Condition
Operating supply voltage	VBAT	2.7~5.5	V	VBAT voltage

●Electrical Characteristics

Unless otherwise specified, Ta is 25°C and VBAT is 3.6V.

Parameter	Symbol	Limits			Unit	Condition
		Min.	Typ.	Max.		
[Circuit current]						
Circuit current 0	IQ0	-	0.1	1	μA	EN=0V
Circuit current 1.0	IQ1.0	-	1.0	2.0	mA	x1.0 Mode, Iout = 0mA
Circuit current 1.5	IQ1.5	-	2.3	3.3	mA	x1.5 Mode, Iout = 0mA
Circuit current 2.0	IQ2.0	-	2.5	3.5	mA	X2.0 Mode, Iout = 0mA

Unless otherwise specified, Ta is 25°C and VBAT is 3.6V.

Parameter	Symbol	Limits			Unit	Condition
		Min.	Typ.	Max.		
[Current driver]						
LED maximum current	ILEDmax	-	-	30	mA	
LED current accuracy	ILEDdiff	-	0.5	5.0	%	ILED=10mA
LED current matching	ILEDmatch	-	0.5	3.0	%	ILED=10mA *1)
LED pin control voltage	VLED	0.08	0.10	0.20	V	Minimum voltage at LED1~LED4 pins
ISSET voltage	ISSET	0.5	0.6	0.7	V	
Oscillation frequency	Fosc	0.8	1.0	1.2	MHz	
Over current limiter	Iov	-	600	900	mA	
LED current limiter	ILEDov	40	60	100	mA	

*1) LED current matching = $(I_{LEDmax} - I_{LEDmin}) / (I_{LEDmax} + I_{LEDmin}) * 100$

ILEDmax : Maximum value of LED1-4 current

ILEDmin : Minimum value of LED1-4 current

Unless otherwise specified, Ta is 25°C and VBAT is 5.5V.

Parameter	Symbol	Limits			Unit	Condition
		Min.	Typ.	Max.		
[Control Signal etc.]						
Input 'H' voltage	VIH	1.4	-	-	V	EN,SEL0,SEL1,SEL2
Input 'L' voltage	VIL	-	-	0.4	V	EN,SEL0,SEL1,SEL2
Input 'H' current1	IiH1	-	18.3	30	μA	EN=5.5V
Input 'H' current2	IiH2	-	0	1	μA	SEL0,SEL1,SEL2=5.5V
Input 'L' current	IiL	-1	0	-	μA	EN,SEL0,SEL1,SEL2=0V

Unless otherwise specified, Ta is 25°C and VBAT is 3.6V.

Parameter	Symbol	Limits			Unit	Condition
		Min.	Typ.	Max.		
[Control Signal etc.]						
UVLO detecting voltage	VUVLO	1.9	2.2	2.5	V	

●Reference Data (Evaluation under LED $V_F=3.2V$)

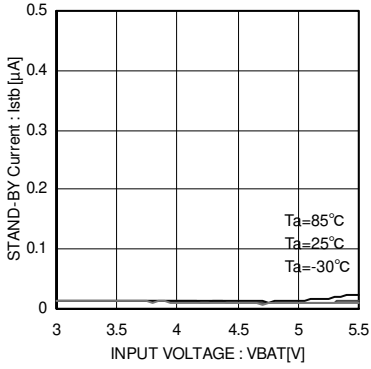

Fig.1 Circuit Current (Standby)

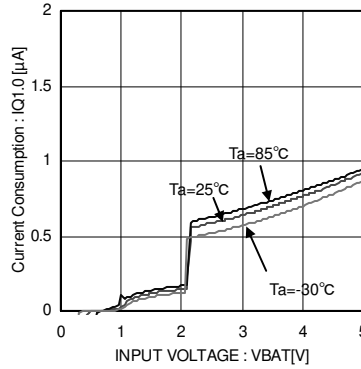

Fig.2 Circuit Current (x1.0 Mode Operation)

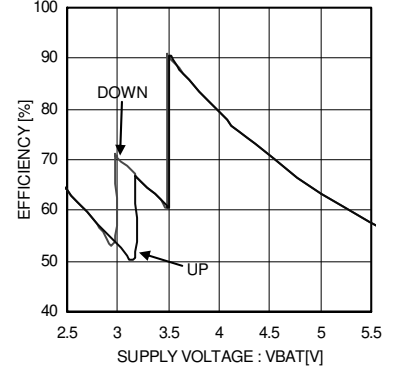

Fig.3 Efficiency Hysteresis (20mA x 4 LEDs)

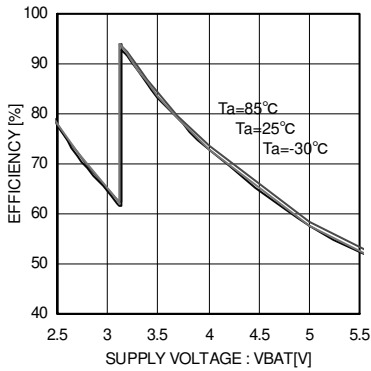

Fig.4 Efficiency (5mA x 4 LEDs)

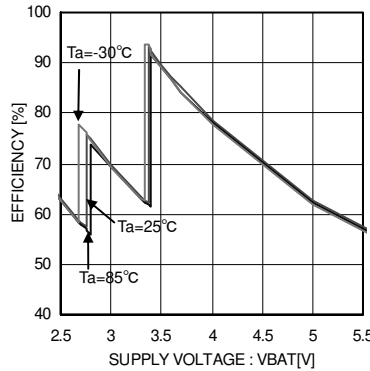

Fig.5 Efficiency (15mA x 4 LEDs)

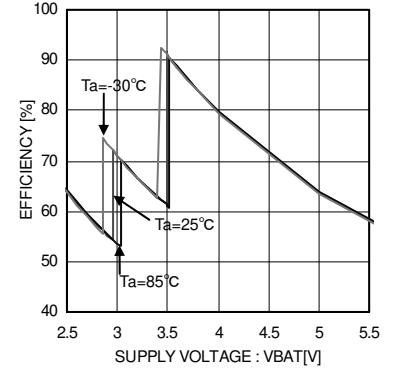

Fig.6 Efficiency (20mA x 4 LEDs)

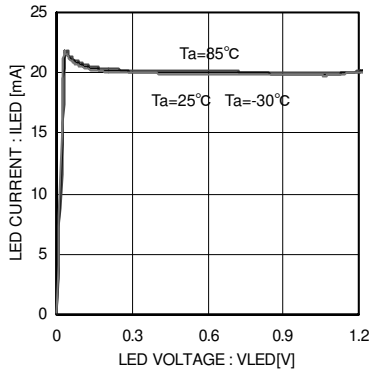

Fig.7 LED Current (20mA) (V_{BAT}=2.7V)

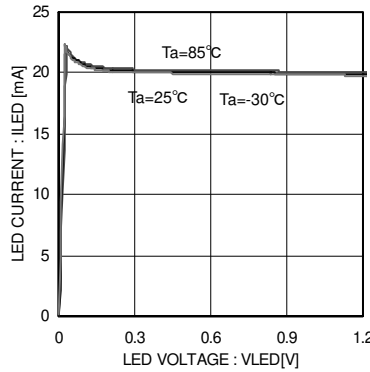

Fig.8 LED Current (20mA) (V_{BAT}=3.6V)

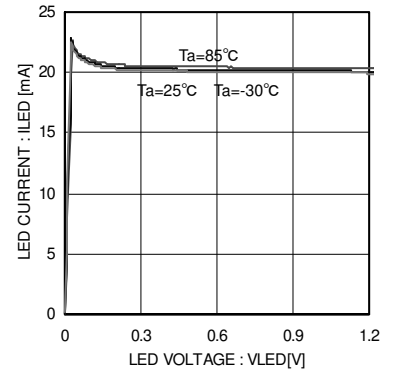

Fig.9 LED Current (20mA) (V_{BAT}=5.5V)

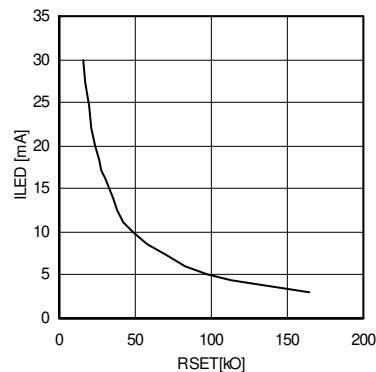

Fig.10 LED Current vs. RSET (Ta=25°C)

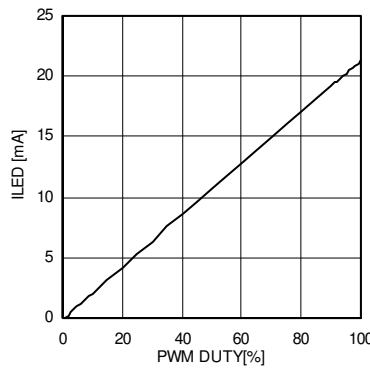

Fig.11 LED Current vs. PWM Duty (Cycle 100Hz)

●Block Diagram, Recommended Circuit Example and Pin Location Diagram

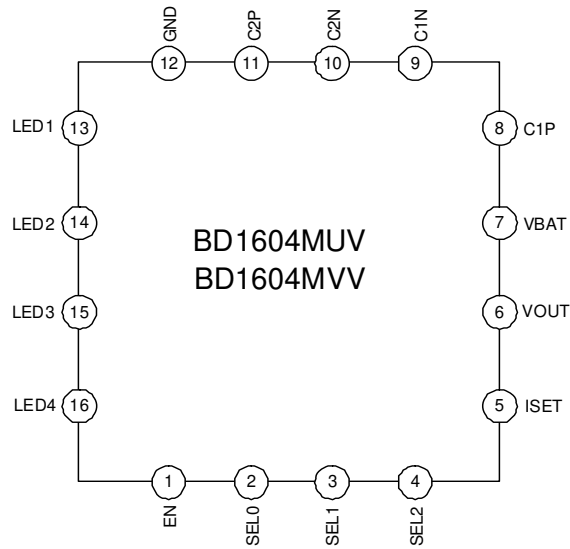

Fig.12 Pin Location Diagram (Top View)

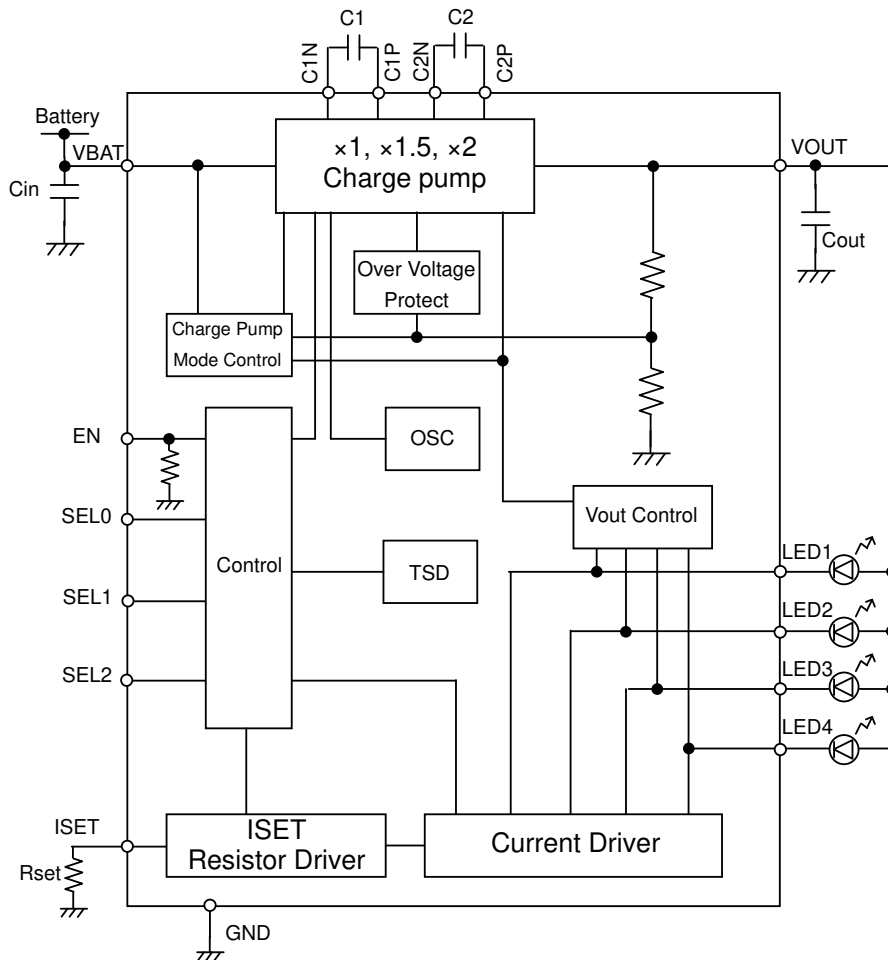

Fig.13 Block Diagram and Recommended Circuit Diagram

[Pin table]

Pin name	Pin number		Pin circuit diagram
	BD1604MUV	BD1604MVV	
EN	1	1	F
SEL0	2	2	E
SEL1	3	3	E
SEL2	4	4	E
ISET	5	5	G
VOUT	6	6	C
VBAT	7	7	H
C1P	8	8	B
C1N	9	9	A
C2N	10	10	A
C2P	11	11	B
GND	12	12	I
LED1	13	13	D
LED2	14	14	D
LED3	15	15	D
LED4	16	16	D

● I/O Equivalence Circuit Diagram

The following shows I/O equivalence circuits.

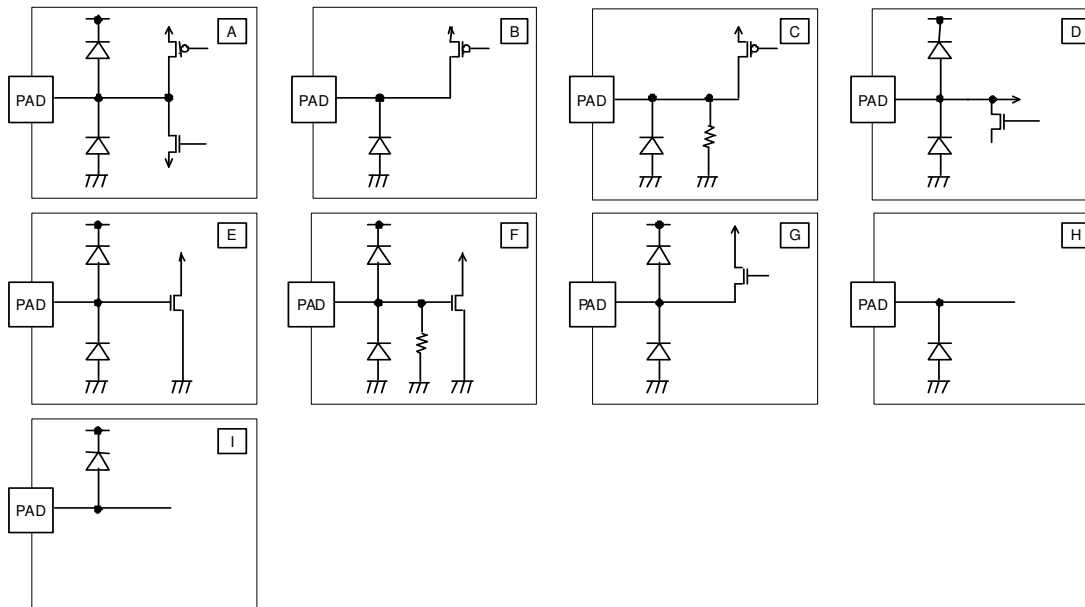

Fig.14 Pin Diagram

●Description of Block Operations

1) LED light control and current control

When LED lights are controlled, H- or L-level voltage is applied to respective control pins.

Current control in the BD1604MUV/MVV can take place via a resistance connected to the ISET pin.

ON/OFF control

SEL2	SEL1	SEL0	LED1	LED2	LED3	LED4
0	0	0	OFF	OFF	OFF	ON
0	0	1	OFF	OFF	ON	OFF
0	1	0	OFF	ON	OFF	OFF
0	1	1	ON	OFF	OFF	OFF
1	0	0	OFF	OFF	ON	ON
1	0	1	OFF	ON	ON	ON
1	1	0	ON	ON	ON	ON
1	1	1	OFF	OFF	OFF	OFF

Rset: See the following table. 0: 0V, 1: VBAT

When handling pins, the LED pins must be connected to VBAT so long as LED is always OFF.

Current control

Rset	165kΩ	97.6kΩ	48.7kΩ	32.4kΩ	24.3kΩ	16.2kΩ
I _{LED}	3mA	5mA	10mA	15mA	20mA	30mA

The LED current can be changed by the Rset value.

$$I_{LED} = 480/Rset$$

The above expression can be used for approximation.

2) Low supply voltage detection circuit (UVLO)

When the IC-applied supply voltage drops, all the circuits including the DC/DC converter are stopped. When supply voltage drops to a detecting voltage, UVLO is activated. When it rises, UVLO is automatically released.

3) Soft start by DC/DC converter startup

When a DC/DC converter is started, soft start is enabled so that output voltage can be increased gradually to prevent output voltage overshooting.

●Application Parts Selection Method

Capacitor (Use the ceramics parts with good frequency and temperature characteristics.)

Symbol	Recommended value	Recommended part	Type
C _{out} , C _{in} , C1, C2	1μF	GRM188B11A105KA61B(MURATA)	Ceramics capacitor

Resistance

Symbol	Recommended value	Recommended part	Set Current Value
Rset	16kΩ	MCR006YZPF Series (ROHM)	30mA
	?		?
	240kΩ		2mA

Connect an input bypass capacitor (CIN) between VBAT and GND pin in proximity. In addition, connect an output capacitor between VOUT and GND pins in proximity. Connect a capacitor between C1P and C1N and also a capacitor between C2P and C2N in proximity to the chips. Connect a resistance in proximity to the ISET pin.

When other than these parts are used, the equivalent parts must be used.

●Cautions on layout pattern

When designing a layout pattern, lay out wires to a power line in a way that the layout pattern impedance can be minimized and connect a bypass capacitor if necessary.

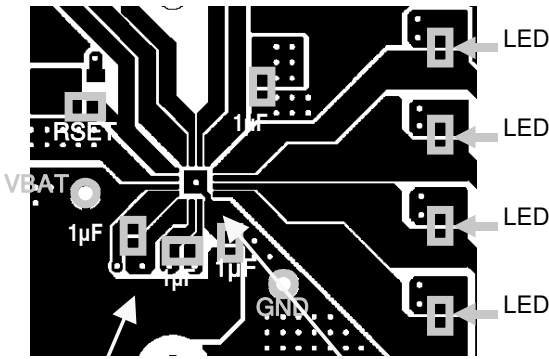

Wiring from the VBAT pin to Cin must meet a low impedance.

The GND pin and Cin must be placed nearby.

Fig.15 Example of BD1604MUV Layout Pattern (Front, Top View)

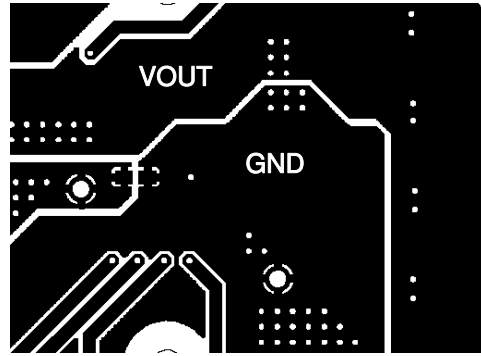

Fig.16 Example of BD1604MUV Layout Pattern (Rear, Top View)

●LED Current Control

There are two methods for LED current control. One method uses an external PWM signal and another changes the resistance value of RREF (RSET) connected to the IREF (ISET) pin. For details, refer to the respective circuit examples. Don't make the setting of 30mA or more per channel for BD1604MUV/MVV.

1) Controlling the current by using the PWM method

The PWN signal must be input to the EN pin.

PWM signal "H" level: 1.4V or more

PWM signal "L" level: 0.4V or less

When PWM Duty is used in an area of 10% or less, the PWM cycle must be a range from 100Hz to 200Hz. When extremely high-speed PWM control takes place, the linearity of LED current value to PWM duty is lost if the PWM duty is small (for example, 10% or less) or it is large (for example, 90% or more).

2) Controlling the current by changing the SET resistance value

$R_{set1} = R_{set2} // \dots // R_{setn}$

This means that the current can be adjusted more finely by adding the types of resistance values.

$$I_{LED} = 480 / R_{set} [A]$$

The approximate LED current can be obtained from the above expression. Because the current of 30mA or more per LED is not permitted, make the setting in a way that the Rset resistance value can be maintained to be greater than or equal to 16kΩ.

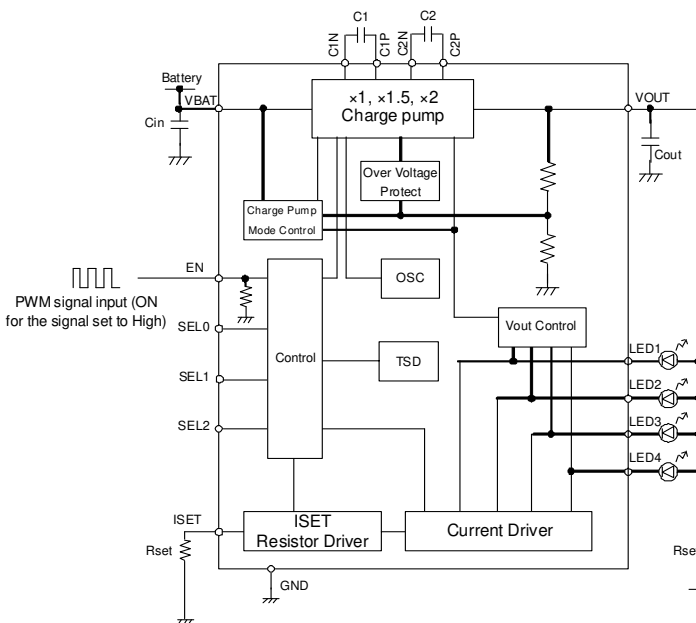

Fig.17 Controlling the Current by Using the PWM Method

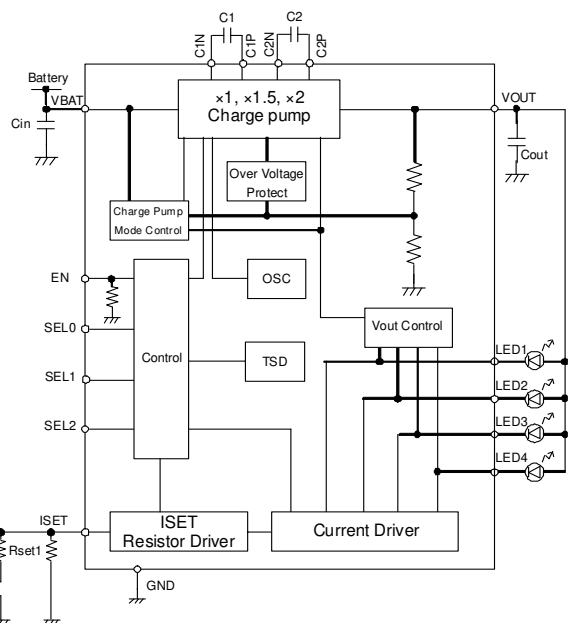

Fig.18 Controlling the Current by Changing the Resistance Value

●Notes for Use

- (1) Absolute Maximum Ratings
An excess in the absolute maximum ratings, such as supply voltage, temperature range of operating conditions, etc., can break down devices, thus making impossible to identify breaking mode such as a short circuit or an open circuit. If any special mode exceeding the absolute maximum ratings is assumed, consideration should be given to take physical safety measures including the use of fuses, etc.
- (2) Operating conditions
These conditions represent a range within which characteristics can be provided approximately as expected. The electrical characteristics are guaranteed under the conditions of each parameter.
- (3) Reverse connection of power supply connector
The reverse connection of power supply connector can break down ICs. Take protective measures against the breakdown due to the reverse connection, such as mounting an external diode between the power supply and the IC's power supply terminal.
- (4) Power supply line
Design PCB pattern to provide low impedance for the wiring between the power supply and the GND lines. In this regard, for the digital block power supply and the analog block power supply, even though these power supplies has the same level of potential, separate the power supply pattern for the digital block from that for the analog block, thus suppressing the diffraction of digital noises to the analog block power supply resulting from impedance common to the wiring patterns. For the GND line, give consideration to design the patterns in a similar manner.
Furthermore, for all power supply terminals to ICs, mount a capacitor between the power supply and the GND terminal. At the same time, in order to use an electrolytic capacitor, thoroughly check to be sure the characteristics of the capacitor to be used present no problem including the occurrence of capacity dropout at a low temperature, thus determining the constant.
- (5) GND voltage
Make setting of the potential of the GND terminal so that it will be maintained at the minimum in any operating state. Furthermore, check to be sure no terminals are at a potential lower than the GND voltage including an actual electric transient.
- (6) Short circuit between terminals and erroneous mounting
In order to mount ICs on a set PCB, pay thorough attention to the direction and offset of the ICs. Erroneous mounting can break down the ICs. Furthermore, if a short circuit occurs due to foreign matters entering between terminals or between the terminal and the power supply or the GND terminal, the ICs can break down.
- (7) Operation in strong electromagnetic field
Be noted that using ICs in the strong electromagnetic field can malfunction them.
- (8) Inspection with set PCB
On the inspection with the set PCB, if a capacitor is connected to a low-impedance IC terminal, the IC can suffer stress. Therefore, be sure to discharge from the set PCB by each process. Furthermore, in order to mount or dismount the set PCB to/from the jig for the inspection process, be sure to turn OFF the power supply and then mount the set PCB to the jig. After the completion of the inspection, be sure to turn OFF the power supply and then dismount it from the jig. In addition, for protection against static electricity, establish a ground for the assembly process and pay thorough attention to the transportation and the storage of the set PCB.
- (9) Input terminals
In terms of the construction of IC, parasitic elements are inevitably formed in relation to potential. The operation of the parasitic element can cause interference with circuit operation, thus resulting in a malfunction and then breakdown of the input terminal. Therefore, pay thorough attention not to handle the input terminals, such as to apply to the input terminals a voltage lower than the GND respectively, so that any parasitic element will operate. Furthermore, do not apply a voltage to the input terminals when no power supply voltage is applied to the IC. In addition, even if the power supply voltage is applied, apply to the input terminals a voltage lower than the power supply voltage or within the guaranteed value of electrical characteristics.
- (10) Ground wiring pattern
If small-signal GND and large-current GND are provided, It will be recommended to separate the large-current GND pattern from the small-signal GND pattern and establish a single ground at the reference point of the set PCB so that resistance to the wiring pattern and voltage fluctuations due to a large current will cause no fluctuations in voltages of the small-signal GND. Pay attention not to cause fluctuations in the GND wiring pattern of external parts as well.

(11) External capacitor

In order to use a ceramic capacitor as the external capacitor, determine the constant with consideration given to a degradation in the nominal capacitance due to DC bias and changes in the capacitance due to temperature, etc.

(12) Not connecting input terminals

In terms of extremely high impedance of CMOS gate, to open the input terminals causes unstable state. Unstable state occurs from the inside gate voltage of p-channel or n-channel transistor into active. As a result, power supply current may increase. And unstable state can also cause unexpected operation of IC. So unless otherwise specified, input terminals not being used should be connected to the power supply or GND line.

(13) Thermal shutdown circuit (TSD)

When junction temperatures become setting temperature or higher, the thermal shutdown circuit operates and turns a switch OFF. The thermal shutdown circuit, which is aimed at isolating the LSI from thermal runaway as much as possible, is not aimed at the protection or guarantee of the LSI. Therefore, do not continuously use the LSI with this circuit operating or use the LSI assuming its operation.

(14) Thermal design

Perform thermal design in which there are adequate margins by taking into account the permissible dissipation (Pd) in actual states of use.

●Thermal Loss

The following conditions must be met for thermal design. (Because the following temperature is only the assured temperature, be sure to consider the margin for design.)

1. The ambient temperature T_a must be 85°C .
2. The IC loss must be smaller than an allowable loss (Pd).

●Power dissipation character

The following shows the power dissipation character.

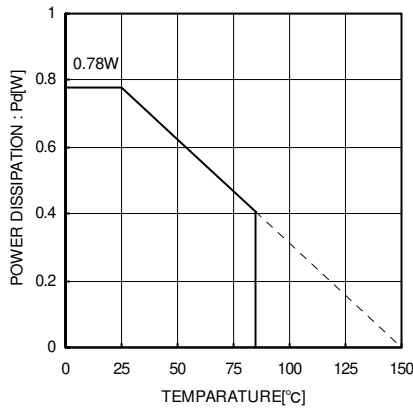

Fig.19 BD1604MVV

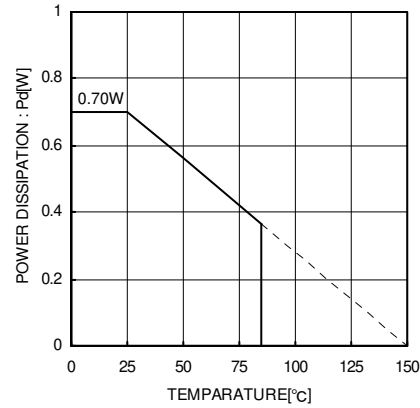

Fig.20 BD1604MUV

Mount board specification

Material : Glass epoxy

Size : 70mm × 70mm × 1.6mm

●Ordering part number

B	D	1	6	0	4	M	U	V	-	E	2
Part No. BD		Part No. 1604				Package MUV: VQFN016V3030 MVV: SQFN016V4040			Packaging and forming specification E2: Embossed tape and reel		

VQFN016V3030

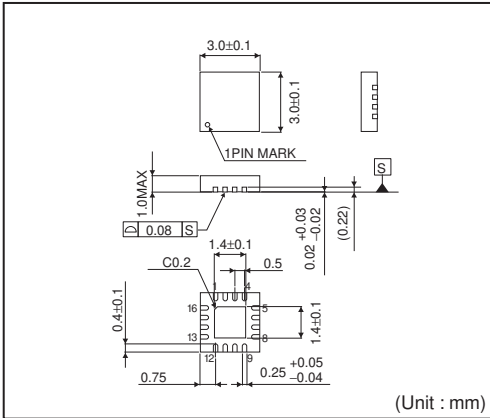

<Tape and Reel information>

Tape	Embossed carrier tape
Quantity	3000pcs
Direction of feed	E2 (The direction is the 1 pin of product is at the upper left when you hold reel on the left hand and you pull out the tape on the right hand)

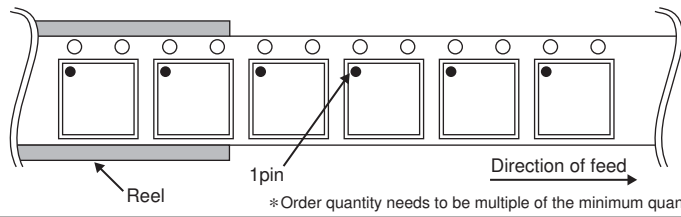

SQFN016V4040

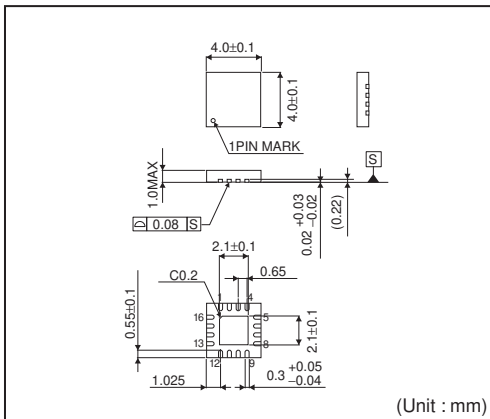

<Tape and Reel information>

Tape	Embossed carrier tape
Quantity	2500pcs
Direction of feed	E2 (The direction is the 1 pin of product is at the upper left when you hold reel on the left hand and you pull out the tape on the right hand)

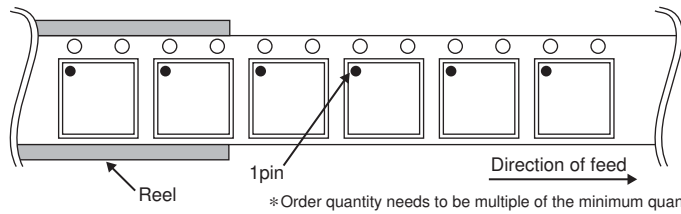

Notes

No copying or reproduction of this document, in part or in whole, is permitted without the consent of ROHM Co.,Ltd.

The content specified herein is subject to change for improvement without notice.

The content specified herein is for the purpose of introducing ROHM's products (hereinafter "Products"). If you wish to use any such Product, please be sure to refer to the specifications, which can be obtained from ROHM upon request.

Examples of application circuits, circuit constants and any other information contained herein illustrate the standard usage and operations of the Products. The peripheral conditions must be taken into account when designing circuits for mass production.

Great care was taken in ensuring the accuracy of the information specified in this document. However, should you incur any damage arising from any inaccuracy or misprint of such information, ROHM shall bear no responsibility for such damage.

The technical information specified herein is intended only to show the typical functions of and examples of application circuits for the Products. ROHM does not grant you, explicitly or implicitly, any license to use or exercise intellectual property or other rights held by ROHM and other parties. ROHM shall bear no responsibility whatsoever for any dispute arising from the use of such technical information.

The Products specified in this document are intended to be used with general-use electronic equipment or devices (such as audio visual equipment, office-automation equipment, communication devices, electronic appliances and amusement devices).

The Products specified in this document are not designed to be radiation tolerant.

While ROHM always makes efforts to enhance the quality and reliability of its Products, a Product may fail or malfunction for a variety of reasons.

Please be sure to implement in your equipment using the Products safety measures to guard against the possibility of physical injury, fire or any other damage caused in the event of the failure of any Product, such as derating, redundancy, fire control and fail-safe designs. ROHM shall bear no responsibility whatsoever for your use of any Product outside of the prescribed scope or not in accordance with the instruction manual.

The Products are not designed or manufactured to be used with any equipment, device or system which requires an extremely high level of reliability the failure or malfunction of which may result in a direct threat to human life or create a risk of human injury (such as a medical instrument, transportation equipment, aerospace machinery, nuclear-reactor controller, fuel-controller or other safety device). ROHM shall bear no responsibility in any way for use of any of the Products for the above special purposes. If a Product is intended to be used for any such special purpose, please contact a ROHM sales representative before purchasing.

If you intend to export or ship overseas any Product or technology specified herein that may be controlled under the Foreign Exchange and the Foreign Trade Law, you will be required to obtain a license or permit under the Law.



Thank you for your accessing to ROHM product informations.
More detail product informations and catalogs are available, please contact us.

ROHM Customer Support System

<http://www.rohm.com/contact/>