



Chipsmall Limited consists of a professional team with an average of over 10 year of expertise in the distribution of electronic components. Based in Hongkong, we have already established firm and mutual-benefit business relationships with customers from,Europe,America and south Asia,supplying obsolete and hard-to-find components to meet their specific needs.

With the principle of “Quality Parts,Customers Priority,Honest Operation,and Considerate Service”,our business mainly focus on the distribution of electronic components. Line cards we deal with include Microchip,ALPS,ROHM,Xilinx,Pulse,ON,Everlight and Freescale. Main products comprise IC,Modules,Potentiometer,IC Socket,Relay,Connector.Our parts cover such applications as commercial,industrial, and automotives areas.

We are looking forward to setting up business relationship with you and hope to provide you with the best service and solution. Let us make a better world for our industry!



Contact us

Tel: +86-755-8981 8866 Fax: +86-755-8427 6832

Email & Skype: info@chipsmall.com Web: www.chipsmall.com

Address: A1208, Overseas Decoration Building, #122 Zhenhua RD., Futian, Shenzhen, China



Sound Processors for Home Theater Systems

7.1ch Sound Processor with Built-in Micro-step Volume

BD34701KS2

General description

The BD34701KS2 is an 8ch independent volume system. The system is designed in such a way, that it can be used as a 7.1ch surround system. Micro-step volume can reduce the switching shock noise when volume changes, so it can achieve a high-quality set. 8ch dual input selector for zone 2 and multi channel input enable the connection of a number of sources.

Key Specifications

- Total harmonic distortion: 0.0004%(Typ.)
- Maximum output voltage: 4.2Vrms(Typ.)
- Output noise voltage: 1.5uVrms(Typ.)
- Residual output noise voltage: 1.0uVrms(Typ.)
- Cross-talk between channels: -105dB(Typ.)
- Cross-talk between selectors: -105dB(Typ.)

Features

- 8ch input selectors
- Micro-step volume can reduce the switching shock noise when volume changes.
- Zone 2 can support.
- 2-wire serial bus control, corresponding to 3.3/5V.

Applications

- Most suitable for the AV receiver, home theater system

Package

SQFP-T52

W(Typ.) x D(Typ.) x H(Max.)

12.00mm x 12.00mm x 1.50mm



SQFP-T52

Typical Application Circuit

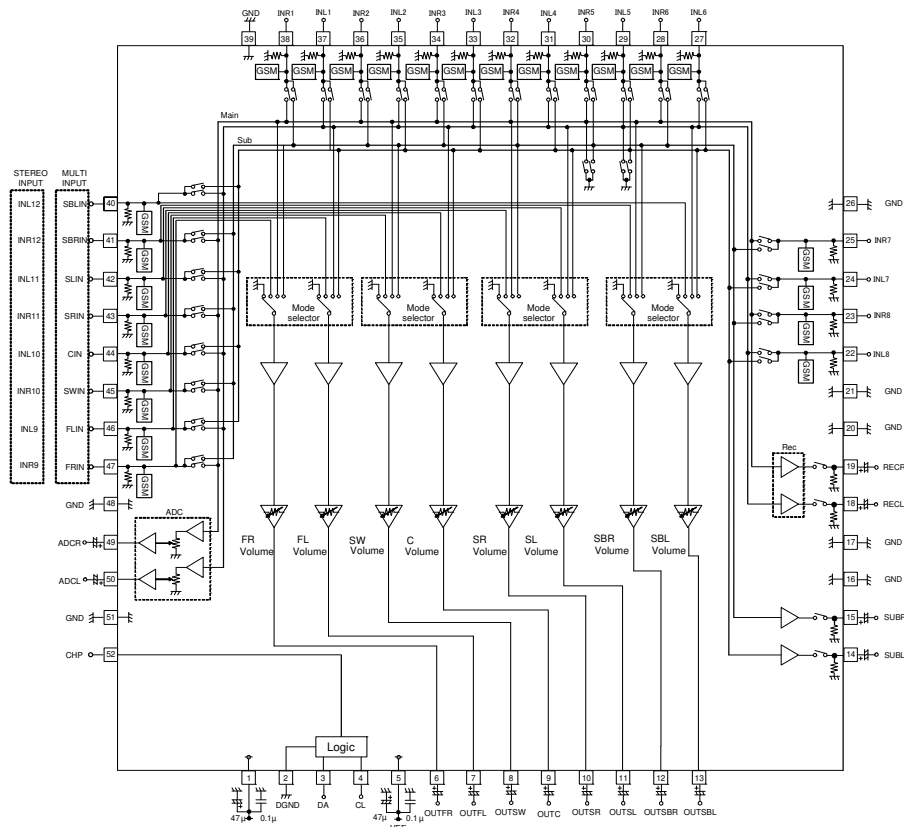

Figure 1. Application Circuit

○Product structure : Silicon monolithic integrated circuit ○This product is not designed protection against radioactive rays

Pin Configuration

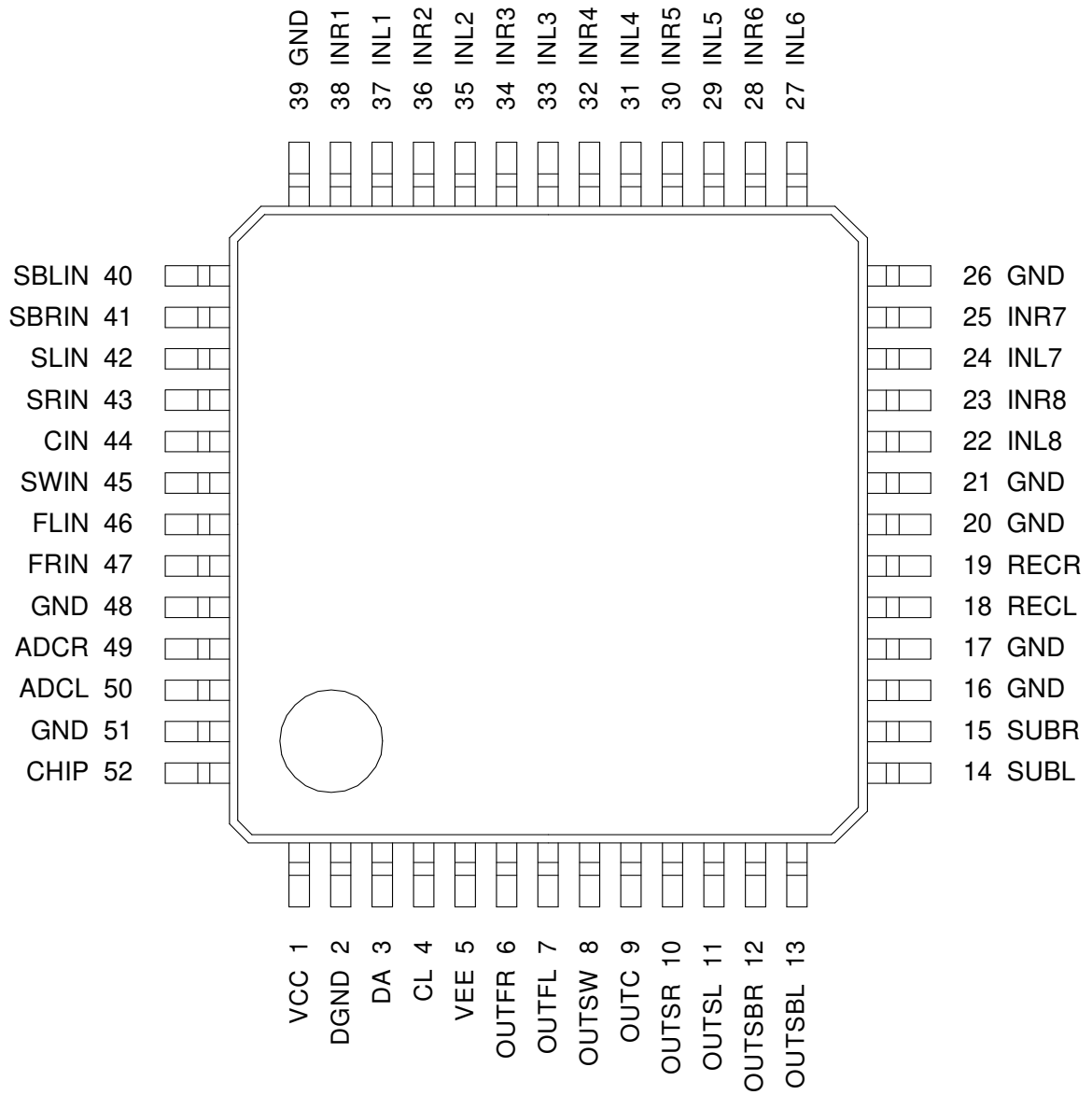

Figure 2. Pin Configuration

Description of terminal

Terminal Number	Symbol	Function	Terminal Number	Symbol	Function
1	VCC	Positive power supply terminal	27	INL6	Lch input terminal 6
2	DGND	Digital ground terminal	28	INR6	Rch input terminal 6
3	DA	Data and latch input terminal	29	INL5	Lch input terminal 5
4	CL	Clock input terminal	30	INR5	Rch input terminal 5
5	VEE	Negative power supply terminal	31	INL4	Lch input terminal 4
6	OUTFR	FRch Output terminal	32	INR4	Rch input terminal 4
7	OUTFL	FLch Output terminal	33	INL3	Lch input terminal 3
8	OUTSW	SWch Output terminal	34	INR3	Rch input terminal 3
9	OUTC	Cch Output terminal	35	INL2	Lch input terminal 2
10	OUTSR	SRch Output terminal	36	INR2	Rch input terminal 2
11	OUTSL	SLch Output terminal	37	INL1	Lch input terminal 1
12	OUTSBR	SBRch Output terminal	38	INR1	Rch input terminal 1
13	OUTSBL	SBLch Output terminal	39	GND	Analog ground terminal
14	SUBL	Lch SUB output terminal	40	SBLIN	SBLch input terminal for DSP
15	SUBR	Rch SUB output terminal	41	SBRIN	SBRch input terminal for DSP
16	GND	Analog ground terminal	42	SLIN	SLch input terminal for DSP
17	GND	Analog ground terminal	43	SRIN	SRch input terminal for DSP
18	RECL	Lch REC output terminal	44	CIN	Cch input terminal for DSP
19	RECR	Rch REC output terminal	45	SWIN	SWch input terminal for DSP
20	GND	Analog ground terminal	46	FLIN	FLch input terminal for DSP
21	GND	Analog ground terminal	47	FRIN	FRch input terminal for DSP
22	INL8	Lch input terminal 8	48	GND	Analog ground terminal
23	INR8	Rch input terminal 8	49	ADCR	Rch output terminal to ADC
24	INL7	Lch input terminal 7	50	ADCL	Lch output terminal to ADC
25	INR7	Rch input terminal 7	51	GND	Analog ground terminal
26	GND	Analog ground terminal	52	CHIP	Chip select

Block Diagram

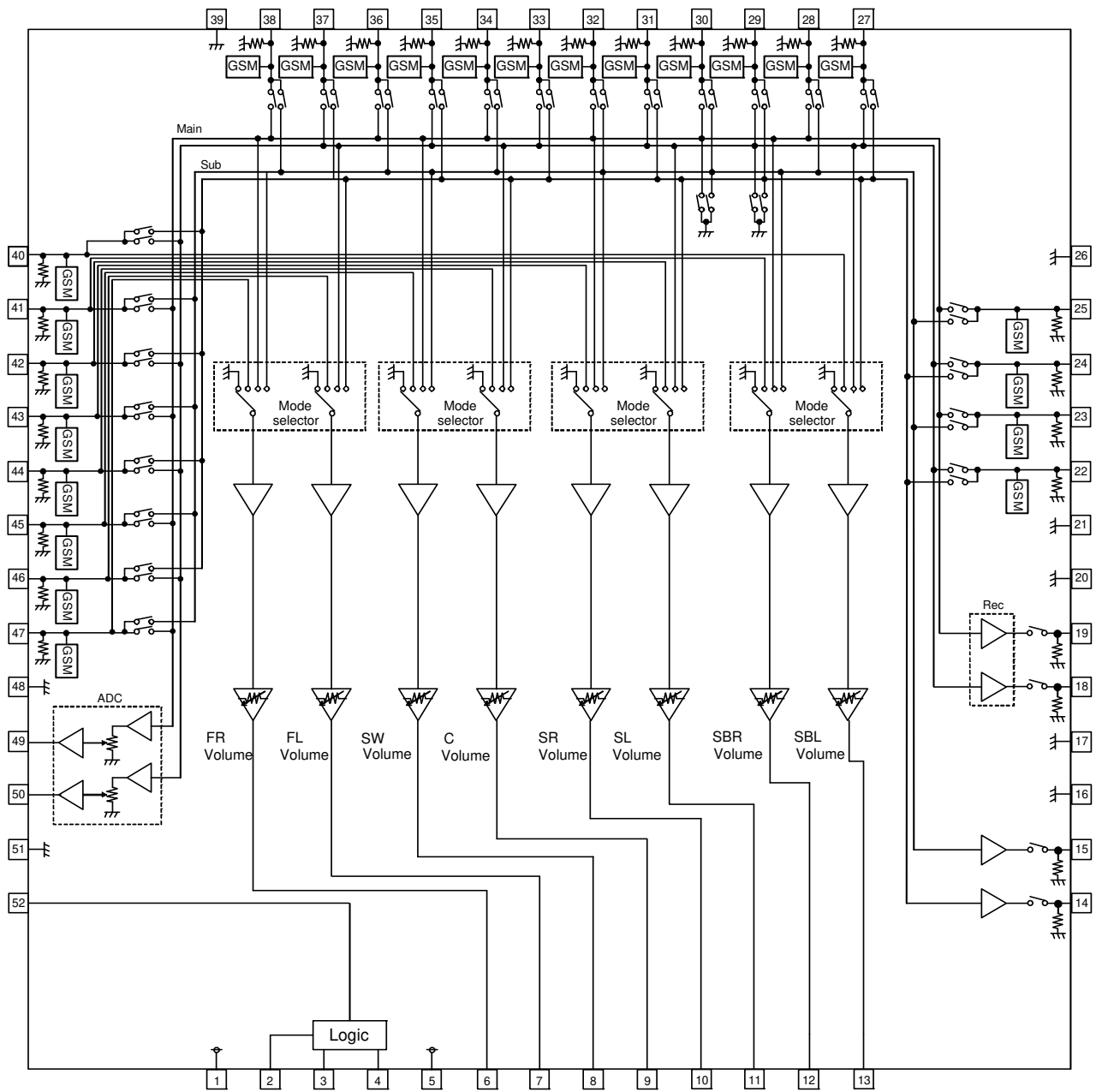

Figure 3. Block Diagram

Absolute Maximum Ratings

Item	Symbol	Rating	Unit
Positive power supply	Vcc	+7.75 (Note1)	V
Negative power supply	Vee	-7.75 (Note1)	V
Power dissipation	Pd	1.30 (Note2)	W
Input voltage	Vin	Vee-0.2 to Vcc+0.2	V
Operating temperature	Topr	-40 to +85 (Note3)	°C
Storage temperature	Tastg	-55 to +125	°C

(Note1) The maximum voltage that can be applied based on GND.

(Note2) This value decreases 13.0mW/°C for Ta=25°C or more. A standard board, 70×70×1.6 mm, shall be mounted.

(Note3) If it within operation voltage range, circuit functions operation is guaranteed within operation temp.

Caution: Operating the IC over the absolute maximum ratings may damage the IC. The damage can either be a short circuit between pins or an open circuit between pins and the internal circuitry. Therefore, it is important to consider circuit protection measures, such as adding a fuse, in case the IC is operated over the absolute maximum ratings.

Operating Condition

Item	Symbol	Rating	Unit
Positive power supply	Vcc	+6.5 to +7.5 (Note4,5)	V
Negative power supply	Vee	-6.5 to -7.5 (Note4,5)	V

(Note4) Applying a voltage based on GND.

(Note5) Within operation temp range, basic circuit function Operation is guaranteed within operation voltage range.

But please confirm set up of constant and element, voltage set up and temp set up on use.

Please watch out except condition stipulated by electrical characteristics within the range, It cannot guarantee standard value of electrical characteristics. But it retains original function.

Electrical characteristic

Unless specified particularly, Ta=25°C, Vcc=7V, Vee=-7V, f=1kHz, Vin=1Vrms, RL=10kΩ,
Stereo input selector(MAIN, SUB)=IN1, Mode selector(FL, FRch)=MAIN, Mode selector(SW, C, SL, SRch)=MULTI,
Mode selector(SBL, SBRch)=MULTI, Input Att=0dB, Input gain=0dB, Volume=0dB.

	Item	Symbol	Limit			Unit	Conditions
			Min.	Typ.	Max.		
TOTAL	Positive circuit current	Iqp	-	22	44	mA	No signal
	Negative circuit current	Iqn	-44	-22	-	mA	No signal
	Output voltage gain	Gv	-1.5	0	1.5	dB	6 to 13pin output
	Channel balance	CB	-0.5	0	0.5	dB	C Channel reference, 6 to 13pin output
	Total harmonic distortion	THD	-	0.0004	0.02	%	BW=400 to 30kHz 6 to 13pin output
	Maximum output voltage	Vom	3.8	4.2	-	Vrms	THD=1%, VOLUME=+10dB 6 to 13pin output
	Output noise voltage	Vno	-	1.5	10	μVrms	Rg=0Ω, BW=IHF-A 6 to 13pin output
	Residual output noise voltage	Vnor	-	1	8	μVrms	Volume=Mute, Rg=0Ω, BW=IHF-A 6 to 13pin output
	Cross-talk between channels	CT	-	-105	-80	dB	Rg=0Ω, BW=IHF-A 6, 7pin output
	Cross-talk between selectors	CS	-	-105	-80	dB	Rg=0Ω, BW=IHF-A 6, 7pin output
	Input impedance	Rin	32	47	62	kΩ	22 to 25, 27 to 38 40 to 47pin input
VOLUME	Maximum attenuation	ATTmax	-	-115	-100	dB	Volume=Mute, BW=IHF-A
REC OUT	Total harmonic distortion	THDR	-	0.0005	0.02	%	BW=400 to 30kHz, RL=6.8kΩ 14,15,18,19pin output

Typical Performance Curve(s)

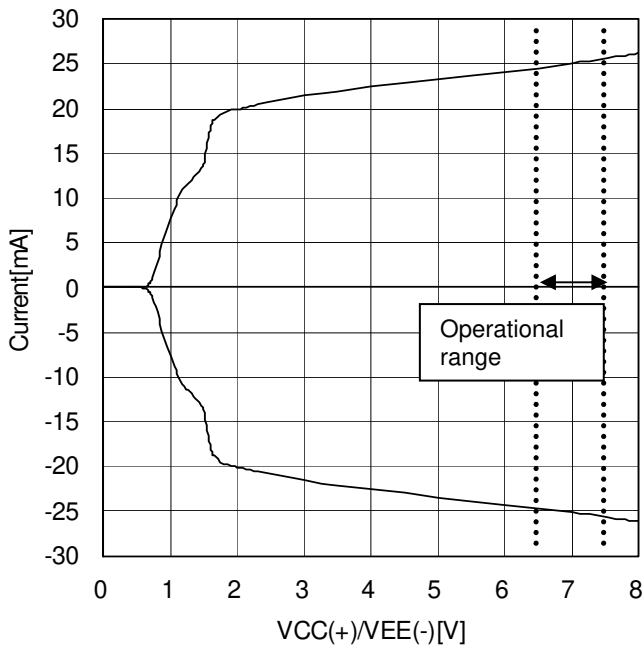

Figure 4. Circuit Currents vs. Circuit Voltage

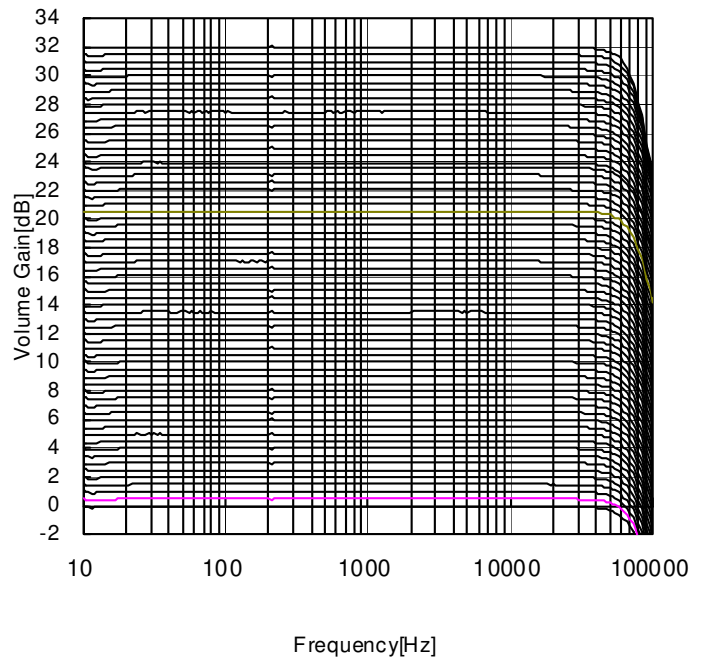

Figure 5. Volume Gain vs. Input Frequency (32dB to 0 dB setting)

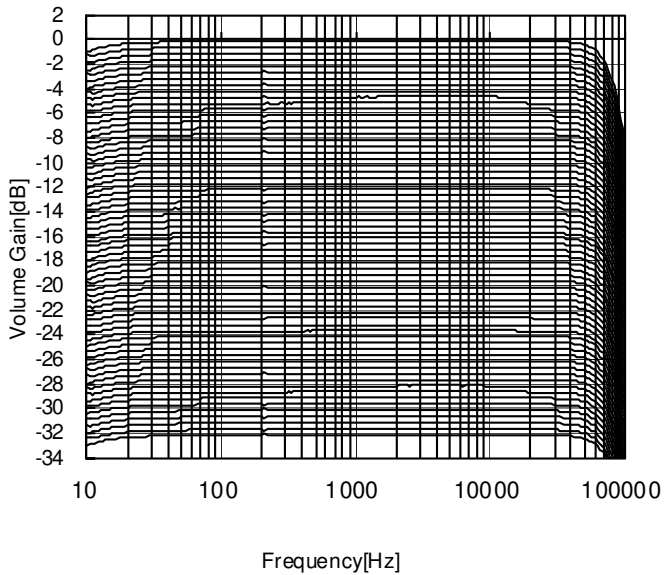

Figure 6. Volume Gain vs. Input Frequency (0dB to -32 dB setting)

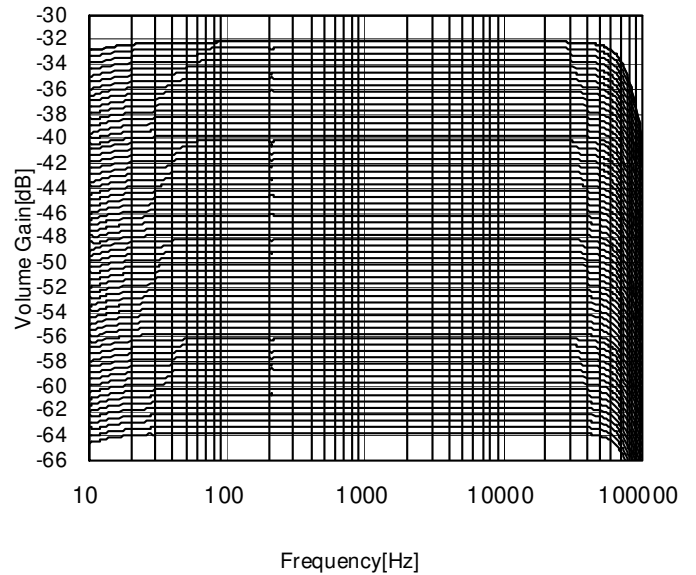

Figure 7. Volume Gain vs. Input Frequency (-32dB to -64 dB setting)

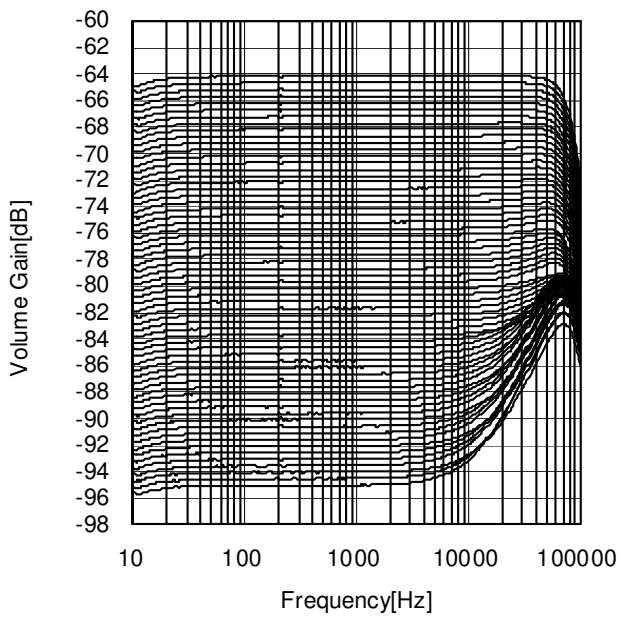

Figure 8. Volume Gain vs. Input Frequency (-64dB to -95 dB setting)

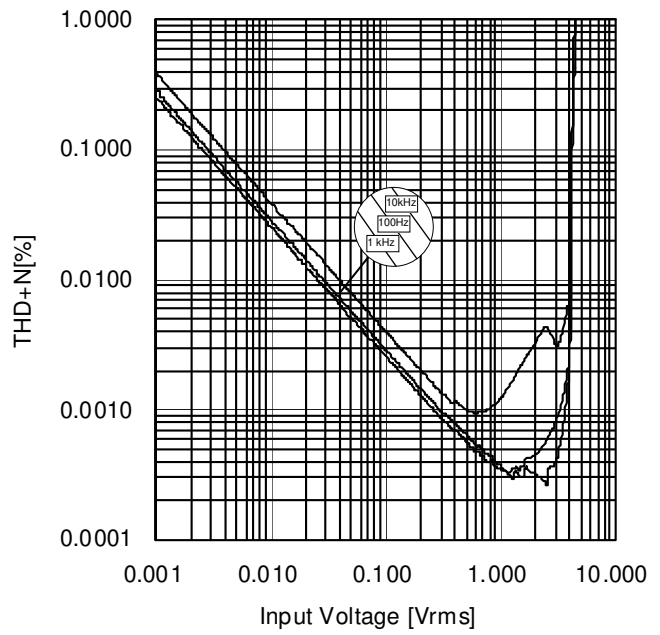

Figure 9. THD + N vs. Input Voltage

Specifications for Control Signal

(1) Timing of control signal

Data is read at a rising edge of clock.

Latch is read at a falling edge of clock. And Data on the latest 16bit are taken in the inside of this IC.

Be sure to set DA and CL to LOW after latching.

1byte=16bit

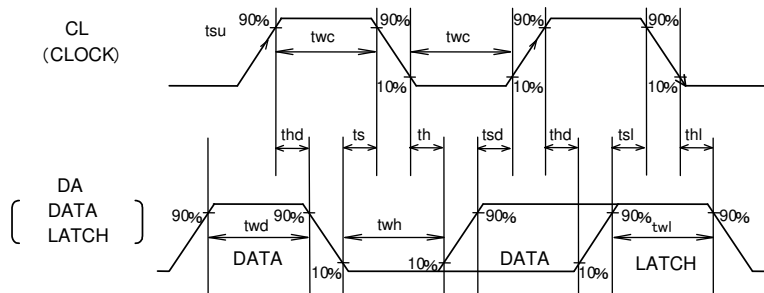

Figure 10. The timing definition of the control signal.

Item	Symbol	Limit			Unit
		Min.	Typ.	Max.	
Clock width	twc	1.0	-	-	μsec
Data width	twd	1.0	-	-	μsec
Latch width	twl	1.0	-	-	μsec
Low hold width	twh	1.0	-	-	μsec
Data setup time (DATA→CLK)	tsd	0.5	-	-	μsec
Data hold time (CLK→DATA)	thd	0.5	-	-	μsec
Latch setup time (CLK→LATCH)	tsl	0.5	-	-	μsec
Latch hold time	thl	0.5	-	-	μsec
Latch Low setup time	ts	0.5	-	-	μsec
Latch Low hold time	th	0.5	-	-	μsec

(2) Voltage of control signal (CL, DA, CHIP)

Item	Conditions	Limit			Unit
		Min.	Typ.	Max. (<Vcc)	
High input voltage	Vcc=+6.5 to +7.5V Vee=-6.5 to -7.5V	2.3	-	5.5	V
Low input voltage		0	-	1.0	V

(3) Basic Structure of Control Data

← Input Direction

D15	D14	D13	D12	D11	D10	D9	D8	D7	D6	D5	D4	D3	D2	D1	D0
Data												Select Address			

(4) Table of Control Data

←Input Direction

Select Address No.	D15	D14	D13	D12	D11	D10	D9	D8	D7	D6	D5	D4	D3	D2	D1	D0	
0	Input Selector (MAIN)						REC ON/OFF	0	0	SUB ON/OFF	1	0	0	Chip Select	0	0	
1	Input Selector (SUB)						0	0	0	0	0	0	0		0	1	
2	Mode Select FL, FRch		Mode Select C, SWch		Mode Select SL, SRch		Mode Select SBL, SBRch		0	ADC ATT			0		1	0	
3	Volume channel Select		Volume										0		1	1	
7	A→B switch-time		B→A switch-time		Base clock		0	0	System reset	0	0	1	1		1		
													BD3843FS (6ch Selector IC)	*	1	0	0
													BD3841FS (9ch Selector IC)	*	1	0	1
													BD3812F (2ch volume IC)	*	1	1	*

- Serial control lines can be shared with BD3843FS(6ch selector IC), BD3841FS(9ch selector IC) and BD3812F(2ch volume IC).
- Initialize all data at every turning on the power supply.

(Example)

←Input direction

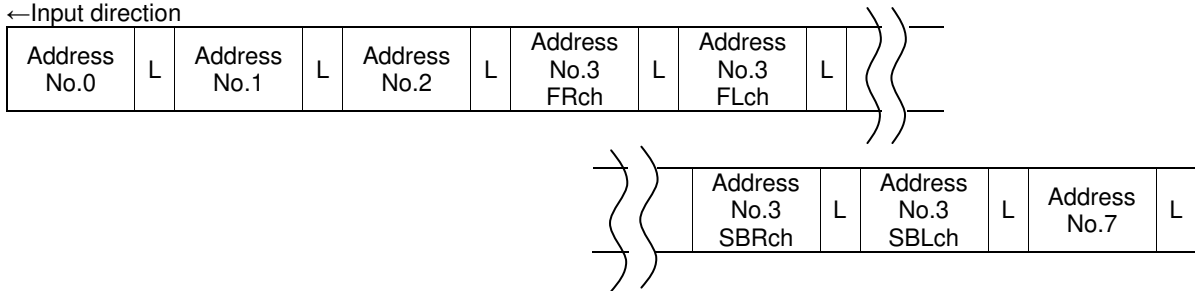

- At the second time after turning on the power supply, eight any data to be changed.

(5) Chip Select Setting Table

CHP terminal condition	D2
0 (LOW)	0
1 (HIGH)	1

BD34701KS2 can be operated in combination with another by setting the CHP terminal.

Select Address No.0 Setting Table

Function & Setting	D15	D14	D13	D12	D11	D10	D9	D8	D7	D6	D5	D4	D3	D2	D1	D0						
Input Selector (MAIN)	MUTE	0	0	0	0	0	0															
	IN1	0	0	0	0	0	1															
	IN2	0	0	0	0	1	0															
	IN3	0	0	0	0	1	1															
	IN4	0	0	0	1	0	0															
	IN5	0	0	0	1	0	1															
	IN6	0	0	0	1	1	0															
	IN7	0	0	0	1	1	1															
	IN8	0	0	1	0	0	0															
	IN9	0	0	1	0	0	1															
	IN10	0	0	1	0	1	0		0	0		1	0	0	Chip Select	0	0					
	IN11	0	0	1	0	1	1															
	IN12	0	0	1	1	0	0															
	Prohibition	0	0	1	1	0	1															
⋮		⋮	⋮	⋮	⋮	⋮																
1		1	1	1	1	1																
REC ON/OFF	OFF	Input Selector (MAIN)						0														
	ON							1														
SUB ON/OFF	OFF															0						
	ON															1						

 : Initial condition

Select Address No.1 Setting Table

Function & Setting	D15	D14	D13	D12	D11	D10	D9	D8	D7	D6	D5	D4	D3	D2	D1	D0	
Input Selector (SUB)	MUTE	0	0	0	0	0	0										
	IN1	0	0	0	0	0	1										
	IN2	0	0	0	0	1	0										
	IN3	0	0	0	0	1	1										
	IN4	0	0	0	1	0	0										
	IN5	0	0	0	1	0	1										
	IN6	0	0	0	1	1	0										
	IN7	0	0	0	1	1	1										
	IN8	0	0	1	0	0	0	0	0	0	0	0	0	0	Chip Select	0	1
	IN9	0	0	1	0	0	1										
	IN10	0	0	1	0	1	0										
	IN11	0	0	1	0	1	1										
	IN12	0	0	1	1	0	0										
	Prohibition	0	0	1	1	0	1										
⋮		⋮	⋮	⋮	⋮	⋮											
1		1	1	1	1	1											

 : Initial condition

Select Address No.2 Setting Table

Function & Setting		D15	D14	D13	D12	D11	D10	D9	D8	D7	D6	D5	D4	D3	D2	D1	D0																							
Mode Selector FL, FRch	MUTE	0	0	Mode Selector C, SWch		Mode Selector SL, SRch		Mode Selector SBL, SBRch		0	ADC ATT			0	Chip Select	1	0																							
	MAIN	0	1																																					
	MULTI	1	0																																					
	SUB	1	1																																					
Mode selector C, SWch	MUTE	Mode Selector FL, FRch		0	0	Mode Selector C, SWch		Mode Selector SL, SRch										Mode Selector SBL, SBRch		ADC ATT			0	Chip Select	1	0														
	MAIN			0	1																																			
	MULTI			1	0																																			
	SUB			1	1																																			
Mode selector SL, SRch	MUTE	Mode Selector FL, FRch		Mode Selector C, SWch		0	0	Mode Selector SL, SRch										Mode Selector SBL, SBRch									ADC ATT			0	Chip Select	1	0							
	MAIN					0	1																																	
	MULTI					1	0																																	
	SUB					1	1																																	
Mode Selector SBL, SBRch	MUTE	Mode Selector FL, FRch		Mode Selector C, SWch		Mode Selector SL, SRch		0	0									Mode Selector SBL, SBRch																ADC ATT			0	Chip Select	1	0
	MULTI							0	1																															
	SUB							1	0																															
	MAIN							1	1																															
ADC ATT	MUTE	Mode Selector FL, FRch		Mode Selector C, SWch		Mode Selector SL, SRch		Mode Selector SBL, SBRch		ADC ATT			0	Chip Select	1	0																								
	0dB																0	0	0																					
	-6dB																0	0	1																					
	-6.5dB																0	1	0																					
	-7.5dB																0	1	1																					
	-9dB																1	0	0																					
	-12dB																1	0	1																					
	Prohibition																1	1	0																					
	1	1	1																																					

 : Initial condition

Select Address No.3 Setting Table

Function & Setting		D15	D14	D13	D12	D11	D10	D9	D8	D7	D6	D5	D4	D3	D2	D1	D0
Volume channel Select	FR	0	0	0	Volume												
	FL	0	0	1													
	SW	0	1	0													
	C	0	1	1													
	SR	1	0	0													
	SL	1	0	1													
	SBR	1	1	0													
	SBL	1	1	1													
Volume	MUTE	Volume Channel Select	1	1	1	1	1	1	1	1	1	1	1	0	Chip Select	1	1
	Prohibition			1	1	1	1	1	1	1	0						
				:	:	:	:	:	:	:	:						
	+32.0dB			0	1	0	0	0	0	0	0	1					
	+31.5dB			0	1	0	0	0	0	0	0	0					
	+31.0dB			0	0	1	1	1	1	1	0	1					
	+30.5dB			0	0	1	1	1	1	0	1	0					
	+30.0dB			0	0	1	1	1	1	0	0	1					
	+29.5dB			0	0	1	1	1	0	1	1	0					
	+29.0dB			0	0	1	1	1	0	1	0	1					
	+28.5dB			0	0	1	1	1	0	0	1	0					
	+28.0dB			0	0	1	1	1	0	0	0	1					
	+27.5dB			0	0	1	1	0	1	1	1	0					
	+27.0dB			0	0	1	1	0	1	1	0	1					
	+26.5dB			0	0	1	1	0	1	0	1	0					
	+26.0dB			0	0	1	1	0	1	0	0	1					
	+25.5dB			0	0	1	1	0	0	1	1	0					
	+25.0dB			0	0	1	1	0	0	1	0	1					
	+24.5dB			0	0	1	1	0	0	0	1	0					
	+24.0dB			0	0	1	1	0	0	0	0	1					
	+23.5dB			0	0	1	0	1	1	1	1	0					
	+23.0dB			0	0	1	0	1	1	1	0	1					
	+22.5dB			0	0	1	0	1	1	0	0	1					
	+22.0dB			0	0	1	0	1	1	0	0	1					
	+21.5dB			0	0	1	0	1	0	1	1	0					
	+21.0dB			0	0	1	0	1	0	1	0	1					
	+20.5dB			0	0	1	0	1	0	0	0	1					
	+20.0dB			0	0	1	0	1	0	0	0	0					
	+19.5dB			0	0	1	0	0	1	1	1	0					
	+19.0dB			0	0	1	0	0	1	1	0	1					
	+18.5dB			0	0	1	0	0	1	0	0	1					
	+18.0dB			0	0	1	0	0	1	0	0	1					
+17.5dB	0	0	1	0	0	0	0	1	1								
+17.0dB	0	0	1	0	0	0	0	1	0								
+16.5dB	0	0	1	0	0	0	0	0	1								
+16.0dB	0	0	1	0	0	0	0	0	0								
+15.5dB	0	0	0	1	1	1	1	1	1								

 : Initial condition

Select Address No.3 Setting Table

Function & Setting		D15	D14	D13	D12	D11	D10	D9	D8	D7	D6	D5	D4	D3	D2	D1	D0
Volume	+15.0dB	Volume Channel Select			1	0	0	0	1	1	1	1	0	0	Chip Select	1	1
	+14.5dB					0	0	0	1	1	1	0	1				
	+14.0dB					0	0	0	1	1	1	0	0				
	+13.5dB					0	0	0	1	1	0	1	1				
	+13.0dB					0	0	0	1	1	0	1	0				
	+12.5dB					0	0	0	1	1	0	0	1				
	+12.0dB					0	0	0	1	1	0	0	0				
	+11.5dB					0	0	0	1	0	1	1	1				
	+11.0dB					0	0	0	1	0	1	1	0				
	+10.5dB					0	0	0	1	0	1	0	1				
	+10.0dB					0	0	0	1	0	1	0	0				
	+9.5dB					0	0	0	1	0	0	1	1				
	+9.0dB					0	0	0	1	0	0	1	0				
	+8.5dB					0	0	0	1	0	0	0	1				
	+8.0dB					0	0	0	1	0	0	0	0				
	+7.5dB					0	0	0	0	1	1	1	1				
	+7.0dB					0	0	0	0	1	1	1	0				
	+6.5dB					0	0	0	0	1	1	0	1				
	+6.0dB					0	0	0	0	1	1	0	0				
	+5.5dB					0	0	0	0	1	0	1	1				
	+5.0dB				0	0	0	0	1	0	1	0					
	+4.5dB				0	0	0	0	1	0	0	1					
	+4.0dB				0	0	0	0	1	0	0	0					
	+3.5dB				0	0	0	0	0	1	1	1					
	+3.0dB				0	0	0	0	0	1	1	0					
	+2.5dB				0	0	0	0	0	1	0	1					
	+2.0dB				0	0	0	0	0	1	0	0					
	+1.5dB				0	0	0	0	0	0	1	1					
	+1.0dB				0	0	0	0	0	0	1	0					
	+0.5dB				0	0	0	0	0	0	0	1					
	Prohibition				0	0	0	0	0	0	0	0					
	-0dB				0	0	0	0	0	0	0	0	0				
	-0.5dB					0	0	0	0	0	0	0	1				
	-1.0dB					0	0	0	0	0	0	1	0				
	-1.5dB					0	0	0	0	0	0	1	1				
	-2.0dB					0	0	0	0	0	1	0	0				
	-2.5dB					0	0	0	0	0	1	0	1				
	-3.0dB					0	0	0	0	0	1	1	0				
	-3.5dB					0	0	0	0	0	1	1	1				
	-4.0dB					0	0	0	0	1	0	0	0				
-4.5dB	0	0	0	0		1	0	0	1								
-5.0dB	0	0	0	0		1	0	1	0								
-5.5dB	0	0	0	0		1	0	1	1								
-6.0dB	0	0	0	0		1	1	0	0								
-6.5dB	0	0	0	0		1	1	0	1								
-7.0dB	0	0	0	0		1	1	1	0								
-7.5dB	0	0	0	0		1	1	1	1								

Select Address No.3 Setting Table

Function & Setting	D15	D14	D13	D12	D11	D10	D9	D8	D7	D6	D5	D4	D3	D2	D1	D0
Volume	-8.0dB	Volume Channel Select	0	0	0	0	0	1	0	0	0	0	0	Chip Select	1	1
	-8.5dB				0	0	0	1	0	0	0	1				
	-9.0dB				0	0	0	1	0	0	1	0				
	-9.5dB				0	0	0	1	0	0	1	1				
	-10.0dB				0	0	0	1	0	1	0	0				
	-10.5dB				0	0	0	1	0	1	0	1				
	-11.0dB				0	0	0	1	0	1	1	0				
	-11.5dB				0	0	0	1	0	1	1	1				
	-12.0dB				0	0	0	1	1	0	0	0				
	-12.5dB				0	0	0	1	1	0	0	1				
	-13.0dB				0	0	0	1	1	0	1	0				
	-13.5dB				0	0	0	1	1	0	1	1				
	-14.0dB				0	0	0	1	1	1	0	0				
	-14.5dB				0	0	0	1	1	1	0	1				
	-15.0dB				0	0	0	1	1	1	1	0				
	-15.5dB				0	0	0	1	1	1	1	1				
	-16.0dB				0	0	1	0	0	0	0	0				
	-16.5dB				0	0	1	0	0	0	0	1				
	-17.0dB				0	0	1	0	0	0	1	0				
	-17.5dB				0	0	1	0	0	0	1	1				
	-18.0dB				0	0	1	0	0	1	0	0				
	-18.5dB				0	0	1	0	0	1	0	1				
	-19.0dB				0	0	1	0	0	1	1	0				
	-19.5dB				0	0	1	0	0	1	1	1				
	-20.0dB				0	0	1	0	1	0	0	0				
	-20.5dB				0	0	1	0	1	0	0	1				
	-21.0dB				0	0	1	0	1	0	1	0				
	-21.5dB				0	0	1	0	1	0	1	1				
	-22.0dB				0	0	1	0	1	1	0	0				
	-22.5dB				0	0	1	0	1	1	0	1				
	-23.0dB				0	0	1	0	1	1	1	0				
	-23.5dB				0	0	1	0	1	1	1	1				
-24.0dB	0	0	1	1	0	0	0	0								
-24.5dB	0	0	1	1	0	0	0	1								
-25.0dB	0	0	1	1	0	0	1	0								
-25.5dB	0	0	1	1	0	0	1	1								
-26.0dB	0	0	1	1	0	1	0	0								
-26.5dB	0	0	1	1	0	1	0	1								
-27.0dB	0	0	1	1	0	1	1	0								
-27.5dB	0	0	1	1	0	1	1	1								
-28.0dB	0	0	1	1	1	0	0	0								
-28.5dB	0	0	1	1	1	0	0	1								
-29.0dB	0	0	1	1	1	0	1	0								
-29.5dB	0	0	1	1	1	0	1	1								
-30.0dB	0	0	1	1	1	1	0	0								
-30.5dB	0	0	1	1	1	1	0	1								
-31.0dB	0	0	1	1	1	1	1	0								

Select Address No.3 Setting Table

Function & Setting	D15	D14	D13	D12	D11	D10	D9	D8	D7	D6	D5	D4	D3	D2	D1	D0		
Volume	-31.5dB	Volume Channel Select	0	0	0	0	1	1	1	1	1	1	0	Chip Select	1	1		
	-32.0dB				0	1	0	0	0	0	0	0						
	-32.5dB				0	1	0	0	0	0	0	0					1	
	-33.0dB				0	1	0	0	0	0	0	1					0	
	-33.5dB				0	1	0	0	0	0	0	1					1	
	-34.0dB				0	1	0	0	0	0	1	0					0	
	-34.5dB				0	1	0	0	0	0	1	0					1	
	-35.0dB				0	1	0	0	0	0	1	1					0	
	-35.5dB				0	1	0	0	0	0	1	1					1	
	-36.0dB				0	1	0	0	1	0	0	0					0	
	-36.5dB				0	1	0	0	1	0	0	0					1	
	-37.0dB				0	1	0	0	1	0	1	0					0	
	-37.5dB				0	1	0	0	1	0	1	0					1	
	-38.0dB				0	1	0	0	1	1	1	0					0	
	-38.5dB				0	1	0	0	1	1	1	0					1	
	-39.0dB				0	1	0	0	1	1	1	1					0	
	-39.5dB				0	1	0	0	1	1	1	1					1	
	-40.0dB				0	1	0	1	0	0	0	0					0	
	-40.5dB				0	1	0	1	0	0	0	0					1	
	-41.0dB				0	1	0	1	0	0	0	1					0	
	-41.5dB				0	1	0	1	0	0	0	1					1	
	-42.0dB				0	1	0	1	0	1	0	1					0	0
	-42.5dB				0	1	0	1	0	1	0	1					0	1
	-43.0dB				0	1	0	1	0	1	0	1					1	0
	-43.5dB				0	1	0	1	0	1	0	1					1	1
	-44.0dB				0	1	0	1	1	1	0	0					0	0
	-44.5dB				0	1	0	1	1	1	0	0					0	1
	-45.0dB				0	1	0	1	1	1	0	1					0	0
	-45.5dB				0	1	0	1	1	1	0	1					1	1
	-46.0dB				0	1	0	1	1	1	1	0					0	0
	-46.5dB				0	1	0	1	1	1	1	0					0	1
	-47.0dB				0	1	0	1	1	1	1	1					1	0
	-47.5dB				0	1	0	1	1	1	1	1					1	1
	-48.0dB				0	1	1	0	0	0	0	0					0	0
-48.5dB	0	1	1	0	0	0	0	0	0	1								
-49.0dB	0	1	1	0	0	0	0	1	0	0								
-49.5dB	0	1	1	0	0	0	0	1	1	1								
-50.0dB	0	1	1	0	0	1	0	0	0	0								
-50.5dB	0	1	1	0	0	1	0	0	1	1								
-51.0dB	0	1	1	0	0	1	1	1	0	0								
-51.5dB	0	1	1	0	0	1	1	1	1	1								
-52.0dB	0	1	1	0	1	0	0	0	0	0								
-52.5dB	0	1	1	0	1	0	0	0	0	1								
-53.0dB	0	1	1	0	1	0	1	0	1	0								
-53.5dB	0	1	1	0	1	0	1	0	1	1								
-54.0dB	0	1	1	0	1	1	1	0	0	0								
-54.5dB	0	1	1	0	1	1	1	0	0	1								

Select Address No.3 Setting Table

Function & Setting	D15	D14	D13	D12	D11	D10	D9	D8	D7	D6	D5	D4	D3	D2	D1	D0
Volume	-55.0dB	Volume Channel Select	0	0	0	1	1	0	1	1	1	0	0	Chip Select	1	1
	-55.5dB				0	1	1	0	1	1	1	1				
	-56.0dB				0	1	1	1	0	0	0	0				
	-56.5dB				0	1	1	1	0	0	0	1				
	-57.0dB				0	1	1	1	0	0	1	0				
	-57.5dB				0	1	1	1	0	0	1	1				
	-58.0dB				0	1	1	1	0	1	0	0				
	-58.5dB				0	1	1	1	0	1	0	1				
	-59.0dB				0	1	1	1	0	1	1	0				
	-59.5dB				0	1	1	1	0	1	1	1				
	-60.0dB				0	1	1	1	1	0	0	0				
	-60.5dB				0	1	1	1	1	0	0	1				
	-61.0dB				0	1	1	1	1	0	1	0				
	-61.5dB				0	1	1	1	1	0	1	1				
	-62.0dB				0	1	1	1	1	1	0	0				
	-62.5dB				0	1	1	1	1	1	0	1				
	-63.0dB				0	1	1	1	1	1	1	0				
	-63.5dB				0	1	1	1	1	1	1	1				
	-64.0dB				1	0	0	0	0	0	0	0				
	-64.5dB				1	0	0	0	0	0	0	1				
	-65.0dB				1	0	0	0	0	0	1	0				
	-65.5dB				1	0	0	0	0	0	1	1				
	-66.0dB				1	0	0	0	0	1	0	0				
	-66.5dB				1	0	0	0	0	1	0	1				
	-67.0dB				1	0	0	0	0	1	1	0				
	-67.5dB				1	0	0	0	0	1	1	1				
	-68.0dB				1	0	0	0	1	0	0	0				
	-68.5dB				1	0	0	0	1	0	0	1				
	-69.0dB				1	0	0	0	1	0	1	0				
	-69.5dB				1	0	0	0	1	0	1	1				
	-70.0dB				1	0	0	0	1	1	0	0				
	-70.5dB				1	0	0	0	1	1	0	1				
	-71.0dB				1	0	0	0	1	1	1	0				
	-71.5dB				1	0	0	0	1	1	1	1				
	-72.0dB				1	0	0	1	0	0	0	0				
	-72.5dB				1	0	0	1	0	0	0	1				
	-73.0dB				1	0	0	1	0	0	1	0				
	-73.5dB				1	0	0	1	0	0	1	1				
	-74.0dB				1	0	0	1	0	1	0	0				
	-74.5dB				1	0	0	1	0	1	0	1				
-75.0dB	1	0	0	1	0	1	1	0								
-75.5dB	1	0	0	1	0	1	1	1								
-76.0dB	1	0	0	1	1	0	0	0								
-76.5dB	1	0	0	1	1	0	0	1								
-77.0dB	1	0	0	1	1	0	1	0								
-77.5dB	1	0	0	1	1	0	1	1								
-78.0dB	1	0	0	1	1	1	0	0								

Select Address No.7 Setting Table

Function & Setting		D15	D14	D13	D12	D11	D10	D9	D8	D7	D6	D5	D4	D3	D2	D1	D0
A→B switching-time	11msec	0	0	0	B→A switching-time			Base clock	0	0	System Reset	0	0	1	Chip Select	1	1
	5msec	0	0	1													
	7msec	0	1	0													
	14msec	0	1	1													
	3msec	1	0	0													
	2msec	1	0	1													
	Prohibition	1	1	0													
1		1	1														
B→A switching-time	11msec	A→B switching-time			0	0	0	Base clock	0	0	System Reset	0	0	1	Chip Select	1	1
	5msec				0	0	1										
	7msec				0	1	0										
	14msec				0	1	1										
	3msec				1	0	0										
	2msec				1	0	1										
	Prohibition				1	1	0										
1		1	1														
Base clock	x1	A→B switching-time			B→A switching-time			0	Base clock	0	System Reset	0	0	1	Chip Select	1	1
	x1/2							1									
System Reset	Normal	A→B switching-time			B→A switching-time			Base clock	0	0	System Reset	0	0	1	Chip Select	1	1
	Reset																

 : Initial condition

Volume changing needs the time that is following Figure. (Ex. It selected 11msec, 22msec need.)

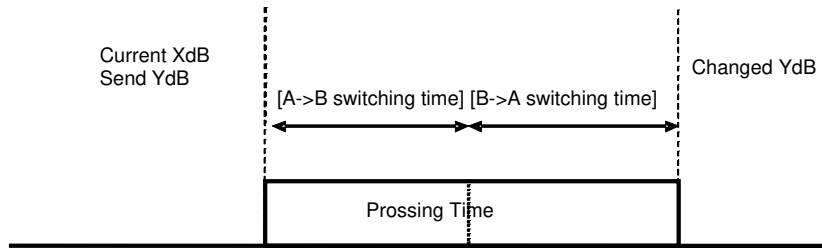

Figure 11. About [A→B switching-time] [B→A switching-time]

Base clock is able to change Internal Oscillator Frequency. For example, when Base clock select $\times 1/2$, A→B and B→A switching time is to be two times. (ex. 11msec→22msec)

○Caution on send data

When send the same channel data among the switching process, internal operation is as below.

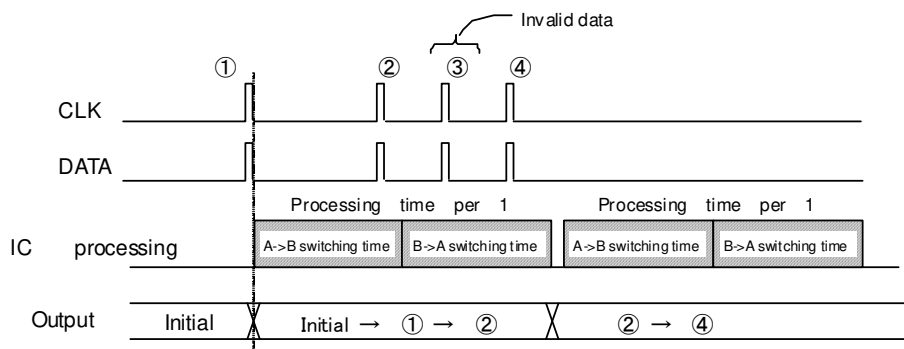

Figure 12. The switching process with send data

②data is sent during A → B switching time, it is valid.

③data and ④data are sent during B → A switching time, it is valid at the next processing time.

But ③data is replaced by ④data.

○About pop noise in gain changing

The level of the pop noise sometimes varies in the difference in output DC offset of the inside condition A and B.

Application Circuit Diagram

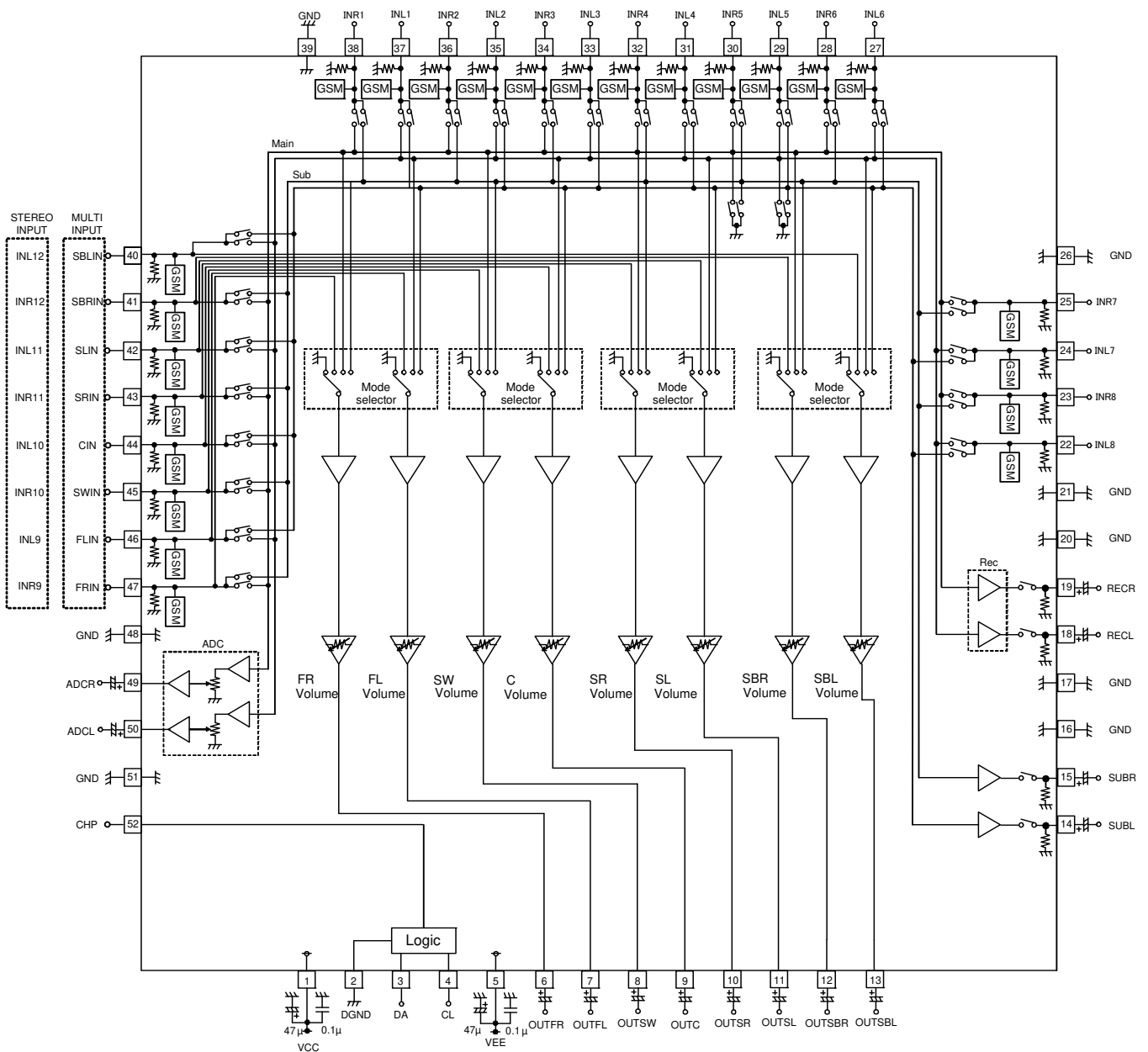

Figure 13. Application Circuit Diagram

Notes on wiring

- ① GND shall be wired from reference point and thicken.
- ② Wiring pattern of CL and DA shall be away from that of analog unit and cross-talk shall not be acceptable.
- ③ Lines of CL and DA of shall not be parallel if possible. The lines shall be shielded, if they are adjacent to each other.
- ④ Please pay attention the wiring pattern of the input terminal of the input selector to the cross talk. Recommend that wiring period is shielded.
- ⑤ Please connect the decoupling capacitor of a power supply in the shortest distance as much as possible to VCC and GND, VEE.

Power Dissipation

About the thermal design by the IC

Characteristics of an IC have a great deal to do with the temperature at which it is used, and exceeding absolute maximum ratings may degrade and destroy elements. Careful consideration must be given to the heat of the IC from the two standpoints of immediate damage and long-term reliability of operation.

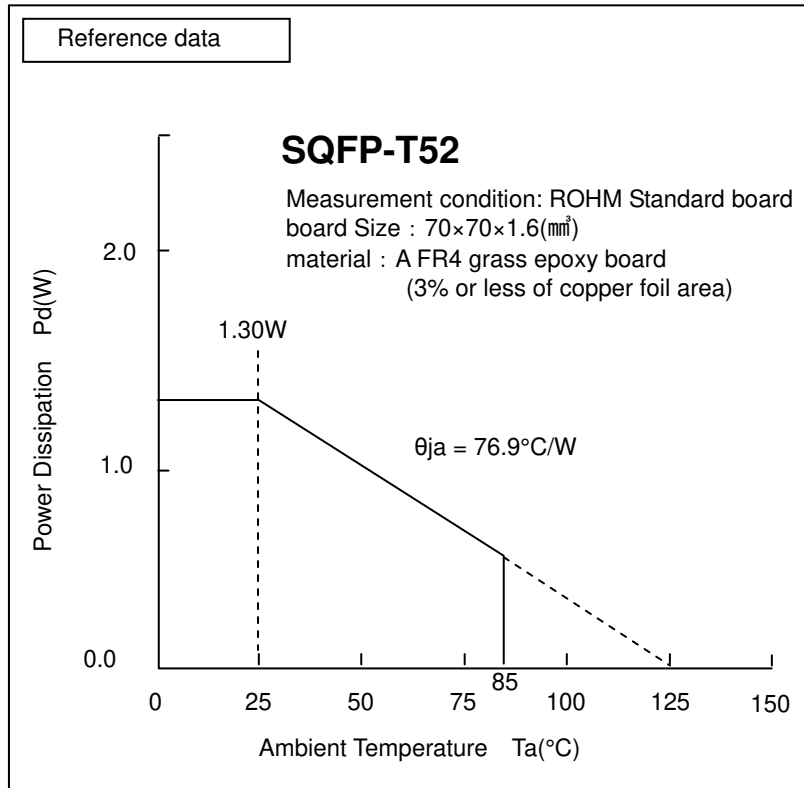

Figure 14. Temperature Derating Curve

Note) Value are actual measurements and are not guaranteed.

Power dissipation values vary according to the board on which the IC is mounted.

I/O equivalence circuit(s)

Terminal Number	Terminal Name	Terminal Voltage (V)	Equivalent Circuit	Description of terminal
16 17 20 21 39 48 51	AGND	0		Analog ground terminals.
1 5	VCC VEE	+7 -7		Positive power supply terminal and
2	DGND	0		Digital ground terminal.
3 4 52	DA CL CHP	-		Input terminals for a clock and data.
6 7 8 9 10 11 12 13 49 50	OUTFR OUTFL OUTSW OUTC OUTSR OUTSL OUTSBR OUTSBL ADCR ADCL	0		Output terminal s for analog sound signal.
14 15 18 19	SUBL SUBR RECL RECR	0		Output terminal s for analog sound signal. (SUB/REC)

Terminal Number	Terminal Name	Terminal Voltage (V)	Equivalent Circuit	Description of terminal
22 23 24 25 27 28 29 30 31 32 33 34 35 36 37 38	INL8 INR8 INL7 INR7 INL6 INR6 INL5 INR5 INL4 INR4 INL3 INR3 INL2 INR2 INL1 INR1	0		Input terminals for stereo sound signal. Input impedance is 47kΩ(Typ.).
40 41 42 43 44 45 46 47	SBLIN SBRIN SLIN SRIN CIN SWIN FLIN FRIN	0		Input terminals for an analog multi sound signal. Input impedance is 47kΩ(Typ.).

Operational Notes

1. Reverse Connection of Power Supply

Connecting the power supply in reverse polarity can damage the IC. Take precautions against reverse polarity when connecting the power supply, such as mounting an external diode between the power supply and the IC's power supply terminals.

2. Power Supply Lines

Design the PCB layout pattern to provide low impedance supply lines. Separate the ground and supply lines of the digital and analog blocks to prevent noise in the ground and supply lines of the digital block from affecting the analog block. Furthermore, connect a capacitor to ground at all power supply pins. Consider the effect of temperature and aging on the capacitance value when using electrolytic capacitors.

3. Vee Voltage

Ensure that no pins are at a voltage below that of the VEE pin at any time, even during transient condition.

4. Ground Wiring Pattern

GND pins which are digital ground(2pin) and analog ground(16,17,20,21,26,39,48,51pin) are not connected inside LSI. These ground pins traces should be routed separately but connected to a single ground at the reference point of the application board. Also ensure that the ground traces of external components do not cause variations on the ground voltage. The ground lines must be as short and thick as possible to reduce line impedance.

5. Thermal Consideration

Should by any chance the power dissipation rating be exceeded the rise in temperature of the chip may result in deterioration of the properties of the chip. The absolute maximum rating of the Pd stated in this specification is when the IC is mounted on a 70mm x 70mm x 1.6mm glass epoxy board. In case of exceeding this absolute maximum rating, increase the board size and copper area to prevent exceeding the Pd rating.

6. Recommended Operating Conditions

These conditions represent a range within which the expected characteristics of the IC can be approximately obtained. The electrical characteristics are guaranteed under the conditions of each parameter.

7. Rush Current

When power is first supplied to the IC, it is possible that the internal logic may be unstable and inrush current may flow instantaneously due to the internal powering sequence and delays, especially if the IC has more than one power supply. Therefore, give special consideration to power coupling capacitance, power wiring, width of ground wiring, and routing of connections.

8. Operation Under Strong Electromagnetic Field

Operating the IC in the presence of a strong electromagnetic field may cause the IC to malfunction.

9. Testing on Application Boards

When testing the IC on an application board, connecting a capacitor directly to IC pin may subject the IC to stress. Always discharge capacitors completely after each process or step. The IC's power supply should always be turned off completely before connecting or removing it from the test setup during the inspection process. To prevent damage from static discharge, ground the IC during assembly and use similar precautions during transport and storage.

10. Inter-pin Short and Mounting Errors

Ensure that the direction and position are correct when mounting the IC on the PCB. Incorrect mounting may result in damaging the IC. Avoid nearby pins being shorted to each other especially to ground, power supply and output pin. Inter-pin shorts could be due to many reasons such as metal particles, water droplets (in very humid environment) and unintentional solder bridge deposited in between pins during assembly to name a few.

11. Unused Input Terminals

Because the input impedance of the terminal becomes 47kΩ when the signal input terminal makes a terminal open, the plunge noise from outside sometimes becomes a problem. Please connect the no using input pin to GND. And please open the no using output pin.