



Chipsmall Limited consists of a professional team with an average of over 10 year of expertise in the distribution of electronic components. Based in Hongkong, we have already established firm and mutual-benefit business relationships with customers from,Europe,America and south Asia,supplying obsolete and hard-to-find components to meet their specific needs.

With the principle of “Quality Parts,Customers Priority,Honest Operation,and Considerate Service”,our business mainly focus on the distribution of electronic components. Line cards we deal with include Microchip,ALPS,ROHM,Xilinx,Pulse,ON,Everlight and Freescale. Main products comprise IC,Modules,Potentiometer,IC Socket,Relay,Connector.Our parts cover such applications as commercial,industrial, and automotives areas.

We are looking forward to setting up business relationship with you and hope to provide you with the best service and solution. Let us make a better world for our industry!



Contact us

Tel: +86-755-8981 8866 Fax: +86-755-8427 6832

Email & Skype: info@chipsmall.com Web: www.chipsmall.com

Address: A1208, Overseas Decoration Building, #122 Zhenhua RD., Futian, Shenzhen, China



Sound Processors for Car Audios

General-Purpose Electronic Volume with Built-in Advanced Switch

BD37034FV-M

General Description

BD37034FV-M is sound processors for car audio. The functions are stereo 5 input selector, volume, 3-band equalizer, loudness, 6ch fader, mixing, HPF for front and rear, LPF for subwoofer, anti-aliasing-filter, Hi-Voltage output, output level detector. Moreover, "Advanced switch circuit", that is ROHM original technology, can reduce various switching noise (ex. No-signal, low frequency likes 20Hz & large signal inputs). "Advanced switch" makes control of microcomputer easier, and can construct high quality car audio system.

Features

- Reduce switching noise of volume, mute, fader volume, mixing volume, bass, middle, treble, loudness by using advanced switch circuit [Possible to control all steps].
- Built-in input selector (single 3 / diff 2).
- Decrease the number of external components by built-in 3-band equalizer filter, LPF for subwoofer, loudness filter. And, possible to control Q, Gv, fo of 3-band equalizer and fc of LPF, Gv, fo of loudness by I²C BUS control freely.
- Built-in mixing volume, Hi-Voltage output.
- Built-in anti-aliasing-filter, anti-GSM-noise-filter.
- Package is SSOP-B28. Putting input-terminals together and output-terminals together can make PCB layout easier and can makes area of PCB smaller.
- It is possible to control by 3.3V / 5V for I²C BUS.
- AEC-Q100 Qualified.

Applications

- It is the optimal for the car audio. Besides, it is possible to use for the audio equipment of mini Compo, micro Compo, TV etc with all kinds.

Typical Application Circuit

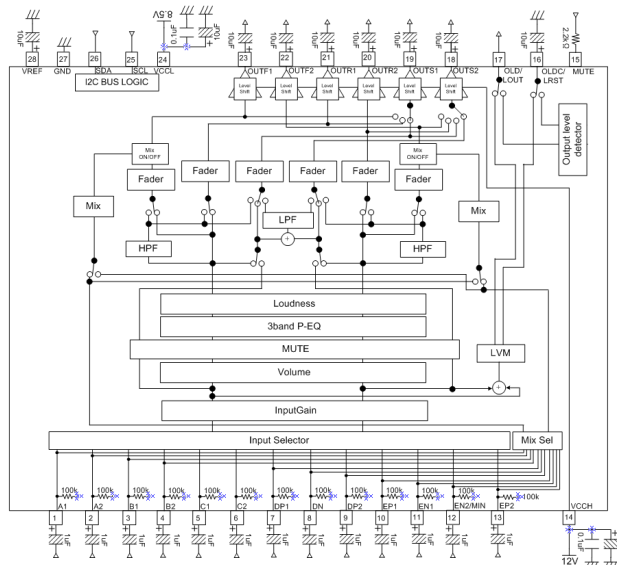

Figure 1. Application Circuit Diagram

Key Specifications

- Total harmonic distortion: 0.004%(Typ.)
- Maximum input voltage: 2.1Vrms(Typ.)
- Cross-talk between selectors: 100dB(Typ.)
- Ripple rejection: -65dB(Typ.)
- Output noise voltage: 6μVrms(Typ.)
- Residual output noise voltage: 4μVrms(Typ.)
- Operating Range of Temperature: -40°C to +85°C

package(s)
SSOP-B28

W(Typ.) x D(Typ.) x H(Max.)
10.00mm x 7.60mm x 1.35mm



SSOP-B28

Pin Configuration

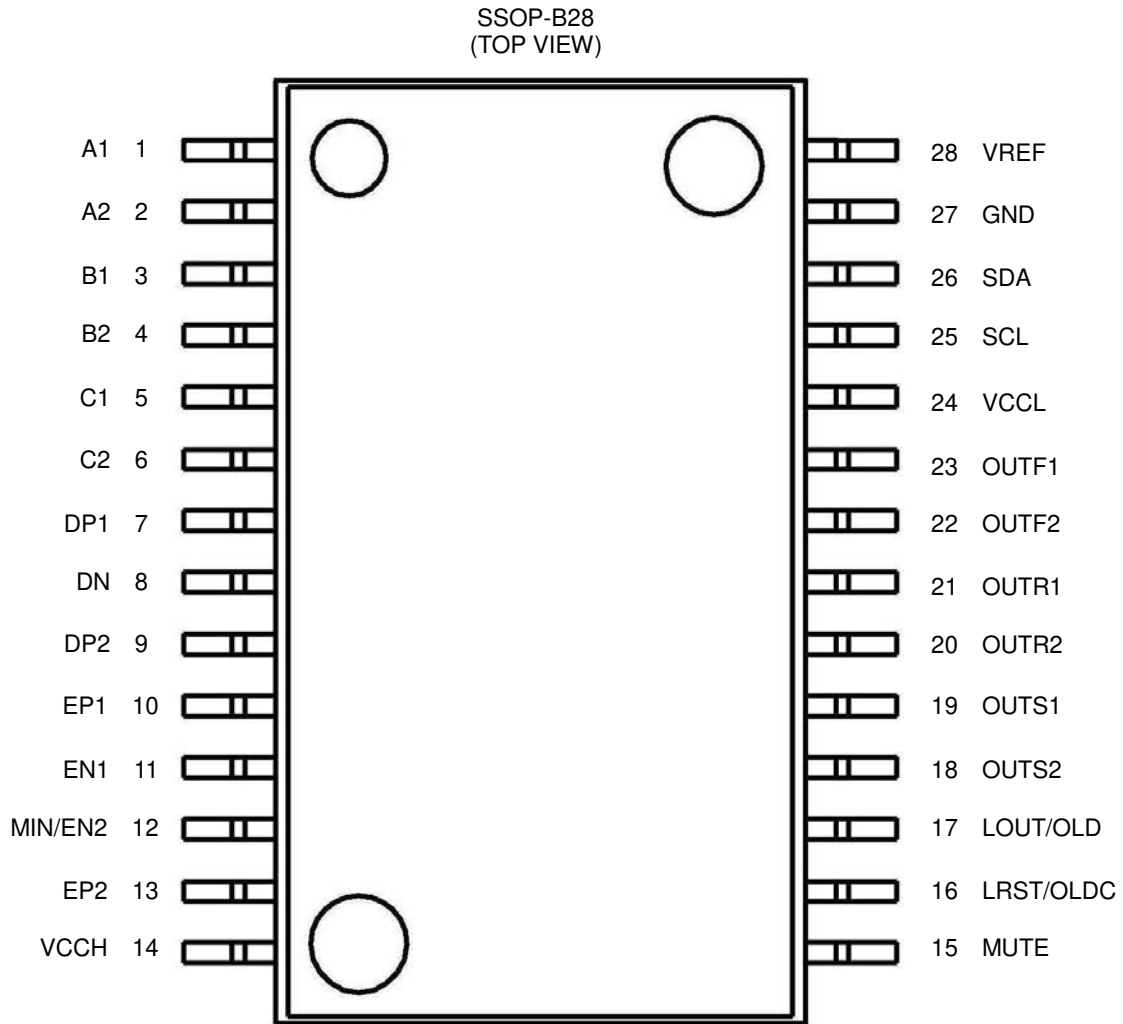

Figure 2. Pin configuration

Pin Descriptions

Terminal Number	Terminal Name	Description	Terminal Number	Terminal Name	Description
1	A1	A input terminal of 1ch	15	MUTE	External compulsory mute terminal
2	A2	A input terminal of 2ch	16	LRST/OLDC	<ul style="list-style-type: none"> Level meter reset terminal Filter output terminal of output level detector
3	B1	B input terminal of 1ch	17	LOUT/OLD	<ul style="list-style-type: none"> Output terminal for Level meter Output terminal of output level detector
4	B2	B input terminal of 2ch	18	OUTS2	SW output terminal of 2ch
5	C1	C input terminal of 1ch	19	OUTS1	SW output terminal of 1ch
6	C2	C input terminal of 2ch	20	OUTR2	Rear output terminal of 2ch
7	DP1	D positive input terminal of 1ch	21	OUTR1	Rear output terminal of 1ch
8	DN	D negative input terminal	22	OUTF2	Front output terminal of 2ch
9	DP2	D positive input terminal of 2ch	23	OUTF1	Front output terminal of 1ch
10	EP1	E positive input terminal of 1ch	24	VCCL	VCCL terminal for power supply
11	EN1	E negative input terminal of 1ch	25	SCL	I ² C Communication clock terminal
12	MIN/EN2	<ul style="list-style-type: none"> Mixing input terminal E negative input terminal of 2ch 	26	SDA	I ² C Communication data terminal
13	EP2	E positive input terminal of 2ch	27	GND	GND terminal
14	VCCH	VCCH terminal for power supply	28	VREF	VREF terminal

Block Diagram

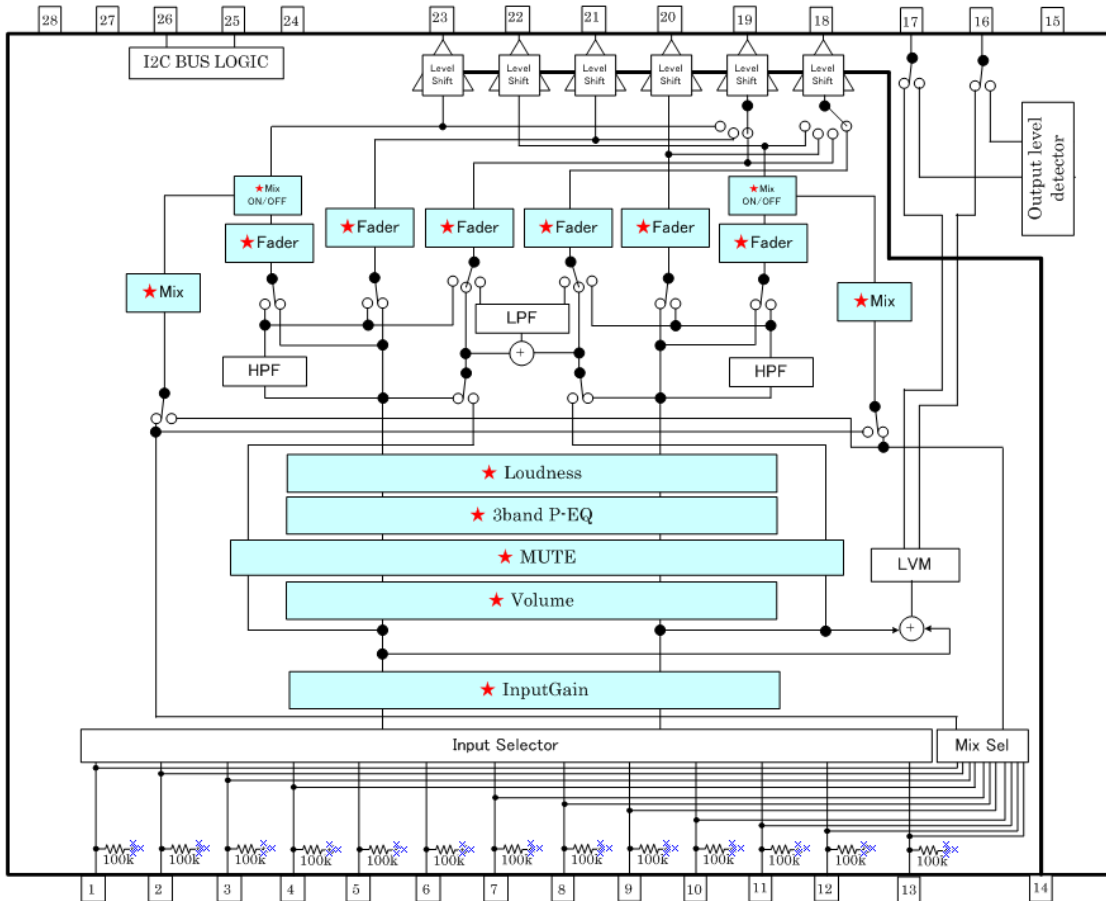

Figure 3. Block Diagram

Absolute Maximum Ratings

Parameter	Symbol	Limits	Unit
Power supply Voltage	VCCL※1	10.0	V
	VCCH※1	13.5	V
Input Voltage	Vin※1	VCCL+0.3 to GND-0.3 Only SCL,SDA 7 to GND-0.3	V
Power Dissipation	Pd	1.06 ※2	W
Storage Temperature	Tastg	-55 to +150	°C

※Maximum voltage which can be impressed referencing GND. Operation using batteries which is used in automobiles directly cannot be guaranteed.

※2 This value decreases 8.5mW/°C for Ta=25°C or more.

ROHM standard board shall be mounted

Thermal resistance $\theta_{ja} = 117.6(^{\circ}\text{C}/\text{W})$

ROHM Standard board Size:70×70×1.6(mm)

Material:A FR4 grass epoxy board(3% or less of copper foil area)

Operating Range

Parameter	Symbol	Limits	Unit
Power supply voltage	VCCL	7.0 to 9.5	V
	VCCH	VCCL to 13.0	V
Temperature	Topr	-40 to +85	°C

Electrical Characteristic

Unless specified particularly Ta=25°C, VCCL=VCCH=8.5V, f=1kHz, Vin=1Vrms, Rg=600Ω, RL=10kΩ, A input
Input Gain, Volume, Tone control, Loudness, Fader=0dB, LPF, HPF=OFF, Mix OFF, anti-aliasing-filter OFF

BLOCK	Item	Symbol	Limit			Unit	Condition
			Min.	Typ.	Max.		
GENERAL	Current upon no signal	I _Q	-	36	49	mA	No signal
	Voltage gain	G _V	-1.5	0	+1.5	dB	G _V =20log(V _{OUT} /V _{IN})
	Channel balance	CB	-1.5	0	+1.5	dB	CB = G _{V1} -G _{V2}
	Total harmonic distortion 1 *	THD+N1	-	0.004	0.05	%	V _{OUT} =1Vrms BW=400-30KHz VCCH=8.5V(Hi-Voltage OFF)
	Total harmonic distortion 2 *	THD+N2	-	0.002	0.05	%	V _{IN} =1Vrms BW=400-30KHz VCCH=12V(Hi-Voltage ON)
	Output noise voltage 1 *	V _{NO1}	-	6	12	μVrms	Rg = 0Ω BW = IHF-A VCCH=8.5V(Hi-Voltage OFF)
	Front/Rear Output noise voltage 2 Front/Rear *	V _{NO2}	-	16	32	μVrms	Rg = 0Ω BW = IHF-A VCCH=12V(Hi-Voltage ON)
	Subwoofer Output noise voltage 3 Subwoofer *	V _{NO3}	-	22	44	μVrms	Rg = 0Ω BW = IHF-A VCCH=12V(Hi-Voltage ON)
	Residual output noise voltage 1 *	V _{NOR1}	-	4	10	μVrms	Fader = -∞dB Rg = 0Ω, BW = IHF-A VCCH=8.5V(Hi-Voltage OFF)
	Front/Rear Residual output noise voltage 2 Front/Rear *	V _{NOR2}	-	11	22	μVrms	Fader = -∞dB Rg = 0Ω, BW = IHF-A VCCH=12V(Hi-Voltage ON)
	Subwoofer Residual output noise voltage 3 Subwoofer *	V _{NOR3}	-	16	32	μVrms	Fader = -∞dB Rg = 0Ω, BW = IHF-A VCCH=12V(Hi-Voltage ON)
	Cross-talk between channels *	CTC	-	-100	-85	dB	Rg = 0Ω CTC=20log(V _{OUT} /V _{IN}) BW = IHF-A
	Ripple rejection	RR	-	-65	-40	dB	f=1kHz, VRR=100mVrms RR=20log(V _{CC IN} /V _{OUT})
Input_Selector	Input impedance	R _{IN}	70	100	130	kΩ	
	Maximum input voltage	V _{IM}	2.0	2.1	-	Vrms	V _{IM} at THD+N(V _{OUT})=1% BW=400-30KHz
	Cross-talk between selectors *	CTS	-	-100	-85	dB	Rg = 0Ω CTS=20log(V _{OUT} /V _{IN}) BW = IHF-A
	Common mode rejection ratio *	CMRR	46	60	-	dB	XP1 and XN input XP2 and XN input CMRR=20log(V _{IN} /V _{OUT}) BW = IHF-A [※X . . . D/E]

BLOCK	Item	Symbol	Limit			Unit	Condition
			Min.	Typ.	Max.		
Input Gain	Maximum input gain	$G_{V\ MAX}$	+14	+16	+18	dB	Input Gain +16dB VIN=100mVrms Gin=20log(VOUT/VIN)
	Minimum input gain	$G_{V\ MIN}$	-2	0	+2	dB	Input Gain 0dB VIN=1Vrms Gin=20log(VOUT/VIN)
	Gain set error	$G_{V\ ERR1}$	-2	0	+2	dB	GAIN=+16to+1dB
Volume	Maximum boost gain	$G_{V\ MAX}$	+13	+15	+17	dB	Volume +15dB VIN=100mVrms Gin=20log(VOUT/VIN)
	Maximum attenuation *	$G_{V\ MIN}$	-83	-79	-75	dB	Volume -79dB VIN=2Vrms Gin=20log(VOUT/VIN)
	Gain set error	$G_{V\ ERR1}$	-2	0	+2	dB	GAIN=+15to+1dB
	Attenuation set error	$G_{V\ ERR2}$	-2	0	+2	dB	ATT=0dBto-79dB
Mute	Mute attenuation *	G_{MUTE}	-	-100	-85	dB	Mute ON Gmute=20log(VOUT/VIN) BW = IHF-A
Bass	Maximum boost gain	$G_{B\ BST}$	+13	+15	+17	dB	Gain=+15dB f=100Hz VIN=100mVrms G _B =20log (VOUT/VIN)
	Maximum cut gain	$G_{B\ CUT}$	-17	-15	-13	dB	Gain=-15dB f=100Hz VIN=2Vrms G _B =20log (VOUT/VIN)
	Gain set error	$G_{B\ ERR}$	-2	0	+2	dB	Gain=+15to-15dB f=100Hz
Middle	Maximum boost gain	$G_{M\ BST}$	+13	+15	+17	dB	Gain=+15dB f=1kHz VIN=100mVrms G _M =20log (VOUT/VIN)
	Maximum cut gain	$G_{M\ CUT}$	-17	-15	-13	dB	Gain=-15dB f=1kHz VIN=2Vrms G _M =20log (VOUT/VIN)
	Gain set error	$G_{M\ ERR}$	-2	0	+2	dB	Gain=+15to-15dB f=1kHz
Treble	Maximum boost gain	$G_{T\ BST}$	+13	+15	+17	dB	Gain=+15dB f=10kHz VIN=100mVrms G _T =20log (VOUT/VIN)
	Maximum cut gain	$G_{T\ CUT}$	-17	-15	-13	dB	Gain=-15dB f=10kHz VIN=2Vrms G _T =20log (VOUT/VIN)
	Gain set error	$G_{T\ ERR}$	-2	0	+2	dB	Gain=+15to-15dB f=10kHz
LOUDNESS	Maximum gain	$G_{L\ MAX}$	-17	-15	-13	dB	Gain -15dB f=800Hz VIN=1Vrms G _L =20log(VOUT/VIN)
	Gain set error	$G_{L\ ERR}$	-2	0	+2	dB	Gain=-15 to-1dB

BLOCK	Item	Symbol	Limit			Unit	Condition
			Min.	Typ.	Max.		
Fader/Mix	Maximum boost gain	$G_{F\text{ BST}}$	+13	+15	+17	dB	Fader/Mix=+15dB $V_{IN}=100\text{mVrms}$ $G_F=20\log(V_{OUT}/V_{IN})$
	Maximum attenuation *	$G_{F\text{ MIN}}$	-	-100	-85	dB	Fader=-∞dB, Mix=OFF $G_F=20\log(V_{OUT}/V_{IN})$ BW = IHF-A
	Gain set error	$G_{F\text{ ERR}}$	-2	0	2	dB	Gain=+15 to +1dB
	Attenuation set error 1	$G_{F\text{ ERR1}}$	-2	0	2	dB	ATT=-1 to -15dB
	Attenuation set error 2	$G_{F\text{ ERR2}}$	-3	0	3	dB	ATT=-16 to -47dB
	Attenuation set error 3	$G_{F\text{ ERR3}}$	-4	0	4	dB	ATT=-48 to -79dB
OUTPUT	Output impedance	R_{OUT}	-	-	50	Ω	$V_{IN}=100\text{mVrms}$
	Maximum output voltage1	V_{OM1}	2.50	2.75	-	Vrms	THD+N=1% BW=400-30KHz VCCH=8.5V, LVS=+3dB (Hi-Voltage OFF)
	Maximum output voltage2	V_{OM2}	3.75	4	-	Vrms	THD+N=1% BW=400-30KHz VCCH=12V(Hi-Voltage ON)
Level Meter	Maximum output voltage	$V_{L\text{ MAX}}$	2.8	3.1	3.5	V	
	Maximum offset voltage	$V_{L\text{ OFF}}$	-	15	100	mV	

*VP-9690A(Average value detection, effective value display) filter by Matsushita Communication is used for * measurement.
Phase between input / output is same.

Typical Performance Curve(s)

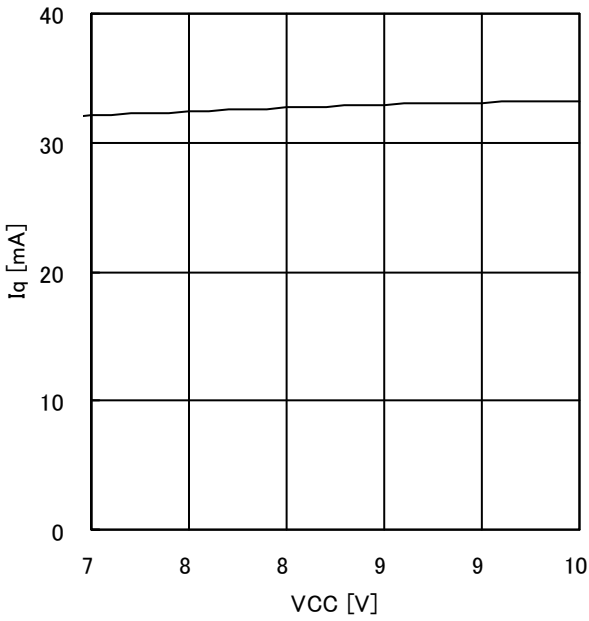

Figure 4. VCCL vs Iq (VCCH=OPEN)

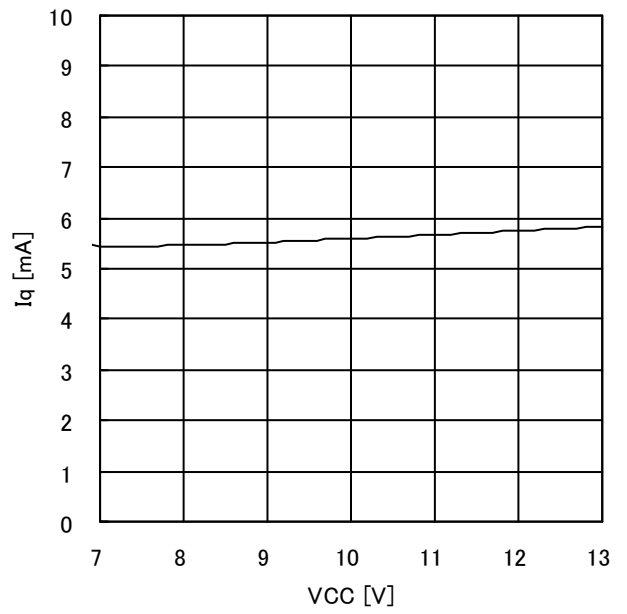

Figure 5. VCCH vs Iq (VCCL=OPEN)

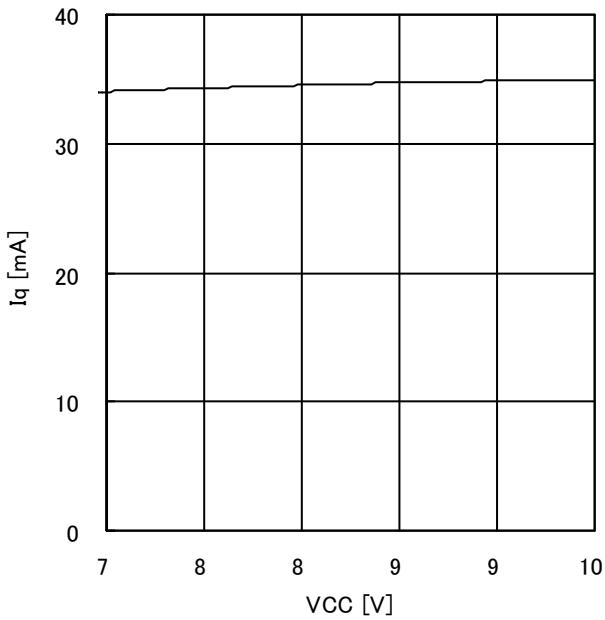

Figure 6. VCCL=VCCH vs Iq

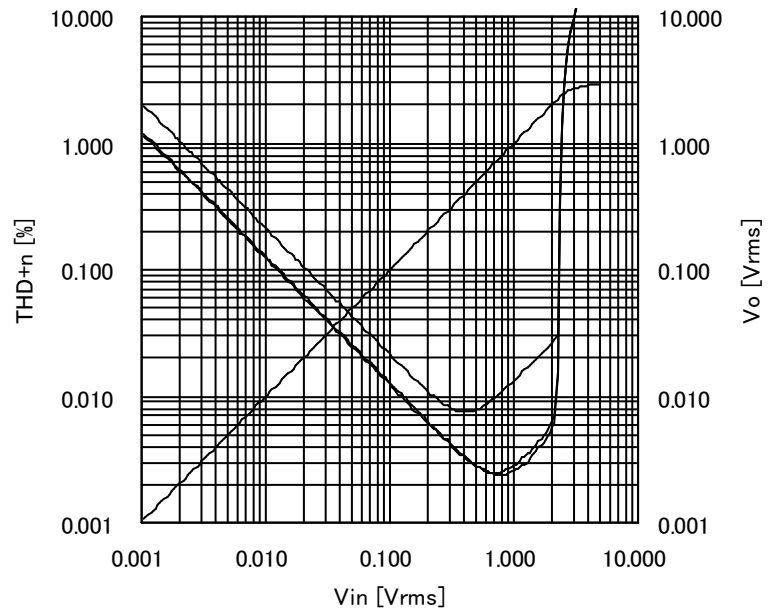

Figure 7. THD vs Vin / Vo

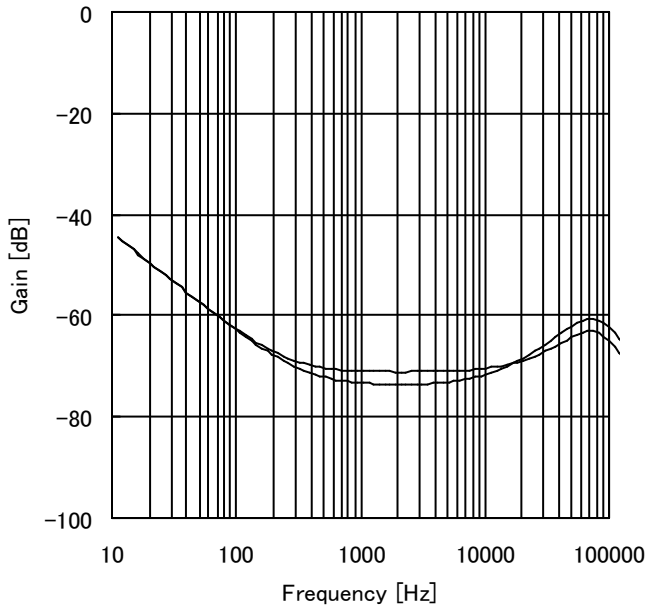

Figure 8. CMRR

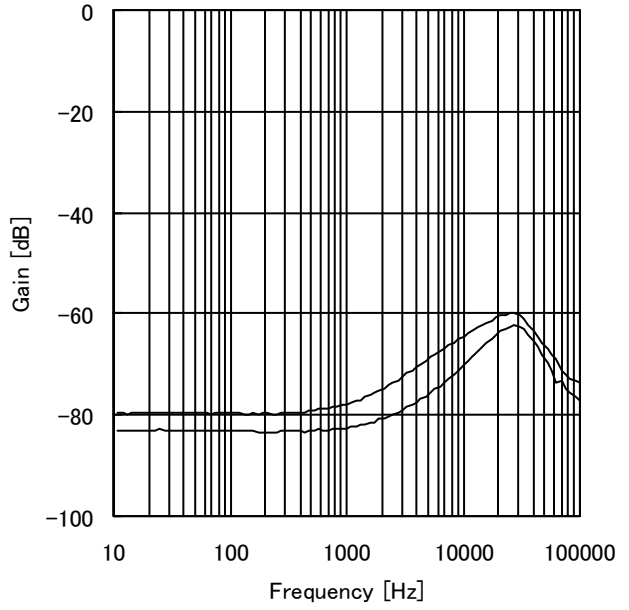

Figure 9. PSRR

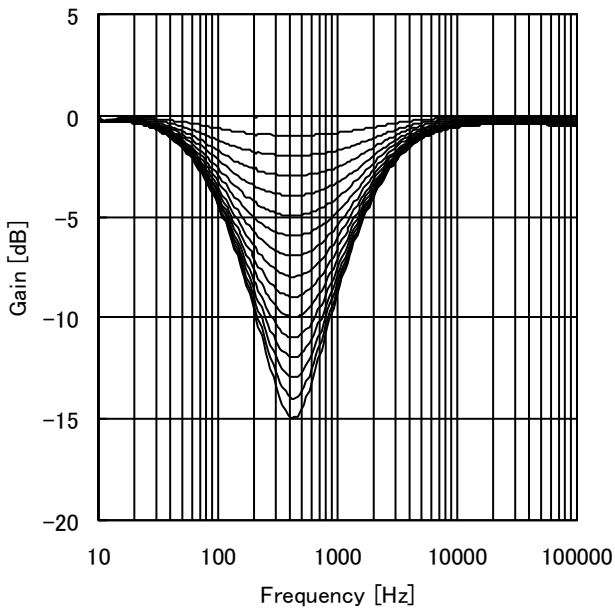

Figure 10. Loudness

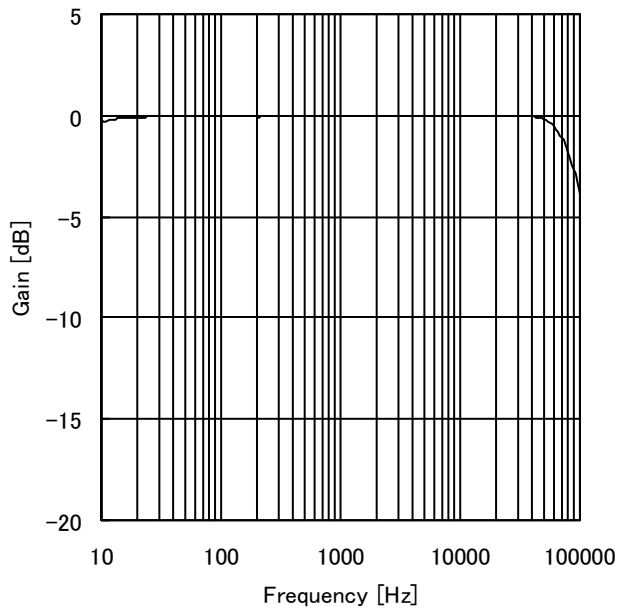

Figure 11. Anti aliasing Filter

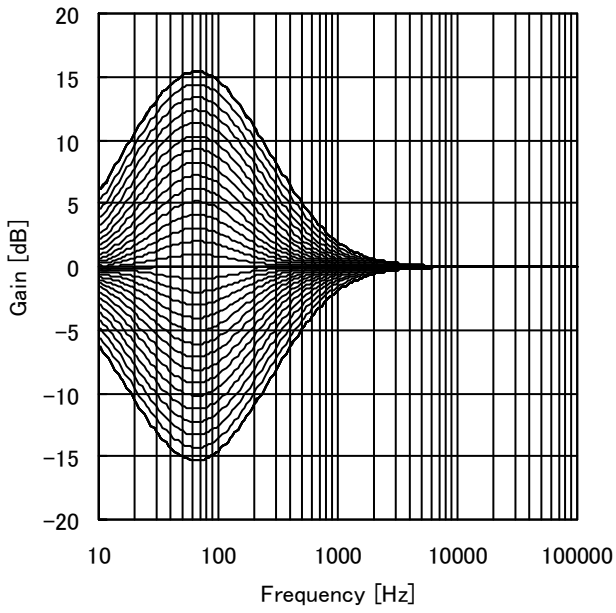

Figure 12. Bass gain vs frequency

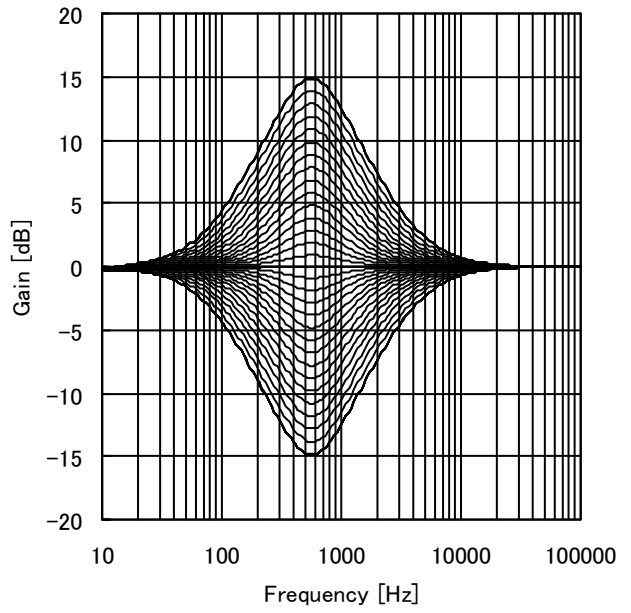

Figure 13. Middle gain vs frequency

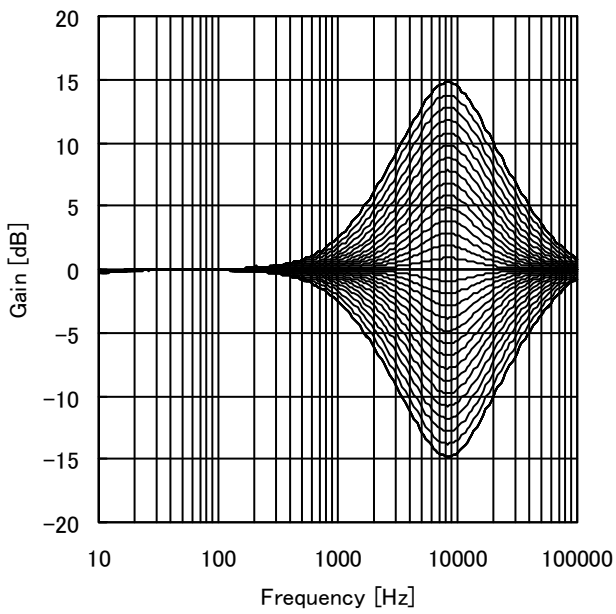

Figure 14. Treble gain vs frequency

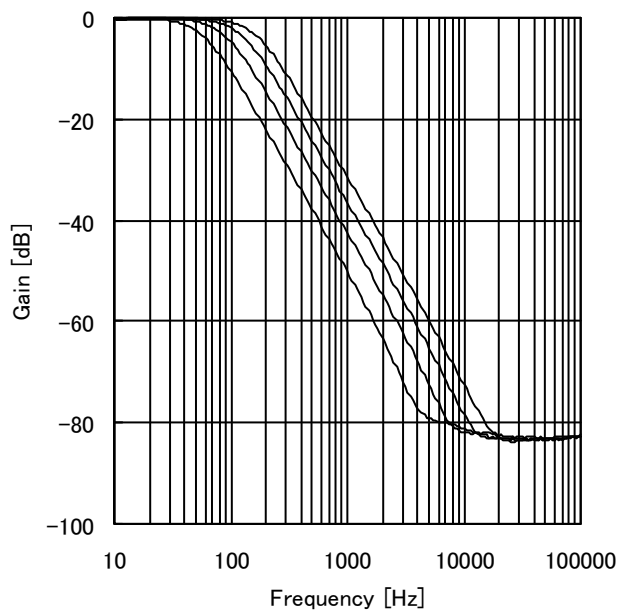

Figure 15. LPF

I²C BUS CONTROL SIGNAL SPECIFICATION

(1) Electrical specifications and timing for bus lines and I/O stages

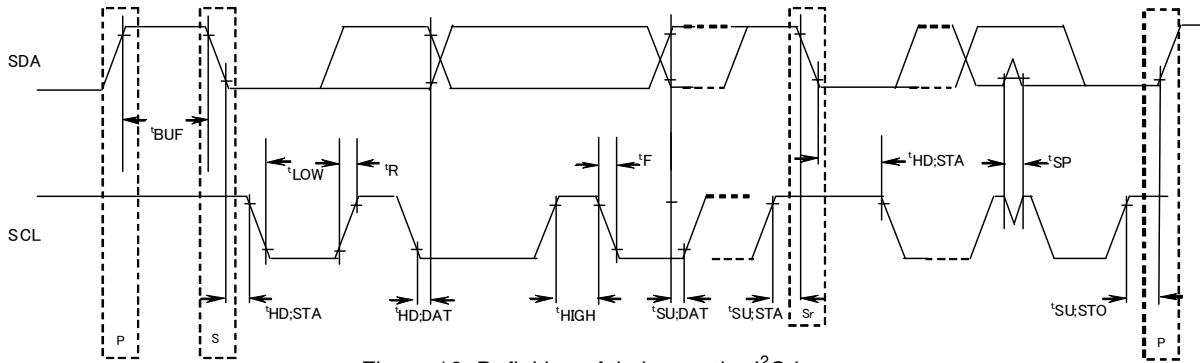

Figure 16. Definition of timing on the I²C-bus

Table 1 Characteristics of the SDA and SCL bus lines for I²C-bus devices (Ta=25°C, VCCL=8.5V)

Parameter	Symbol	Fast-mode I ² C-bus		Unit
		Min.	Max.	
1 SCL clock frequency	fSCL	0	400	kHz
2 Bus free time between a STOP and START condition	tBUF	1.3	—	μS
3 Hold time (repeated) START condition. After this period, the first clock pulse is generated	tHD;STA	0.6	—	μS
4 LOW period of the SCL clock	tLOW	1.3	—	μS
5 HIGH period of the SCL clock	tHIGH	0.6	—	μS
6 Set-up time for a repeated START condition	tSU;STA	0.6	—	μS
7 Data hold time	tHD;DAT	0	—	μS
8 Data set-up time	tSU;DAT	100	—	ns
9 Set-up time for STOP condition	tSU;STO	0.6	—	μS

All values referred to VIH min. and VIL max. Levels (see Table 2).

Table 2 Characteristics of the SDA and SCL I/O stages for I²C-bus devices

Parameter	Symbol	Fast-mode devices		Unit
		Min.	Max.	
10 LOW level input voltage	VIL	-0.3	1	V
11 HIGH level input voltage	VIH	2.3	5	V
12 Pulse width of spikes which must be suppressed by the input filter.	tSP	0	50	ns
13 LOW level output voltage: at 3mA sink current	VOL1	0	0.4	V
14 Input current each I/O pin with an input voltage between 0.4V and 4.5V	li	-10	10	μA

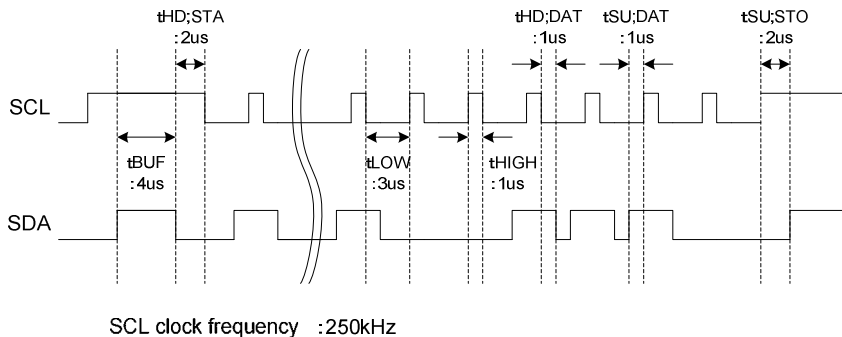

Figure 17. Command timing example in the I²C data transmission

(2) I²C BUS FORMAT

MSB	LSB	MSB	LSB	MSB	LSB		
S	Slave Address	A	Select Address	A	Data	A	P
1bit	8bit	1bit	8bit	1bit	8bit	1bit	1bit
	S	= Start conditions (Recognition of start bit)					
	Slave Address	= Recognition of slave address. 7 bits in upper order are voluntary. The least significant bit is "L" due to writing.					
	A	= ACKNOWLEDGE bit (Recognition of acknowledgement)					
	Select Address	= Select every of volume, bass and treble.					
	Data	= Data on every volume and tone.					
	P	= Stop condition (Recognition of stop bit)					

(3) I²C BUS Interface Protocol

1) Basic form

S	Slave Address	A	Select Address	A	Data	A	P
MSB	LSB	MSB	LSB	MSB	LSB		

2) Automatic increment (Select Address increases (+1) according to the number of data)

S	Slave Address	A	Select Address	A	Data1	A	Data2	A	...	DataN	A	P
MSB	LSB	MSB	LSB	MSB	LSB	MSB	LSB	MSB	LSB	MSB	LSB	

- (Example) ① Data 1 is set as data of Select Address (20h).
 ② Data 2 is set as data of Select Address +1 (28h).
 ③ Data N is set as data of Select Address +N-1.

3) Configuration unavailable for transmission (In this case, only Select Address 1 is set.)

S	Slave Address	A	Select Address1	A	Data	A	Select Address 2	A	Data	A	P
MSB	LSB	MSB	LSB	MSB	LSB	MSB	LSB	MSB	LSB	MSB	LSB

(Note) If any data is transmitted as Select Address 2 next to data, It is recognized as data, not as Select Address 2.

(4) Slave Address

MSB	A6	A5	A4	A3	A2	A1	A0	R/W	LSB	
	1	0	0	0	0	0	0	0		80H

(5) Select Address and Data

Items	Select Address (hex)	Data							
		MSB	Data						LSB
		D7	D6	D5	D4	D3	D2	D1	D0
Initial Setup1	01	Advanced Switch ON/OFF	Anti Alias Filter ON/OFF	Advanced Switch Time of Volume/Fader/Mix /Tone/Loudness		Level Shift	Hi-voltage ON/OFF	Advanced Switch Time of Mute	
LPF Setup	02	LPF Phase 0°/180°	Level Meter Reset	Subwoofer Output Selector		Subwoofer Input Selector1	Subwoofer LPF fc		
Initial Setup2	03	Mixing Input Selector			Loudness f0		0	0	Level Meter ON/OFF
Initial Setup3	04	1ch Mix Input sel	2ch Mix Input sel	Rear Input Selector	Front Input Selector	Subwoofer Input Selector2		HPF fc	
Input Selector	05	Full-diff Type	0	0	Input Selector				
Input Gain	06	MUTE ON/OFF	0	0	Input Gain				
Volume Gain	20	Volume Gain / Attenuation							
Fader 1ch Front	28	Fader Gain / Attenuation							
Fader 2ch Front	29	Fader Gain / Attenuation							
Fader 1ch Rear	2A	Fader Gain / Attenuation							
Fader 2ch Rear	2B	Fader Gain / Attenuation							
Fader 1ch Sub	2C	Fader Gain / Attenuation							
Fader 2ch Sub	2D	Fader Gain / Attenuation							
Mixing1 Gain	30	Mixing Gain / Attenuation							
Mixing2 Gain	31	Mixing Gain / Attenuation							
Bass setup	41	0	0	Bass f0		0	0	Bass Q	
Middle setup	44	0	0	Middle f0		0	0	Middle Q	
Treble setup	47	0	0	Treble f0		0	0	0	Treble Q
Bass Gain	51	Bass Boost/Cut	0	0	Bass Gain				
Middle Gain	54	Middle Boost/Cut	0	0	Middle Gain				
Treble Gain	57	Treble Boost/Cut	0	0	Treble Gain				
Loudness Gain	75	0	HICUT		Loudness Gain				
Output Level Detector	90	0	0	Threshold Level Select		OUT F1 ON/OFF	OUT F2 ON/OFF	OUT R1 ON/OFF	OUT R2 ON/OFF
Initial Setup4	A0	0	0	0	0	0	0	0	0
Initial Setup5	A1	0	0	0	0	0	0	0	0
Initial Setup6	A2	0	1	0	1	0	0	0	1
Initial Setup7	A3	0	0	1	0	0	0	0	0
System Reset	FE	1	0	0	0	0	0	0	1

 : Advanced Switch

※(Set up bit (It is written with "0" by the above table) which hasn't been used in "0".

Note

1. In function changing of the hatching part, it works Advanced switch..
2. Upon continuous data transfer, the Select Address is circulated by the automatic increment function, as shown below.

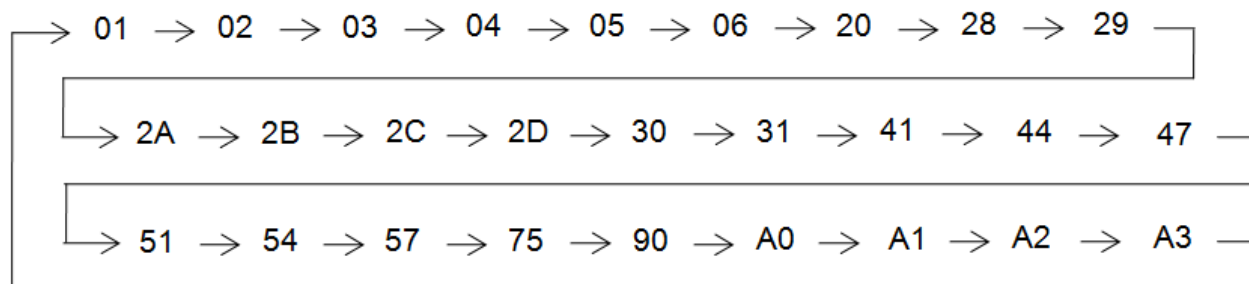

3. For the function of input selector and subwoofer input select etc, it is not corresponded for advanced switch.
Therefore, please apply mute on the side of a set when changes these setting.
4. When using mute function of this IC at the time of changing input selector, please switch mute ON/OFF for waiting advanced-mute time.

Select address 01(hex) Default:8'ha4

Function Name	Mode	Initial Setup							
		MSB D7	D6	D5	D4	D3	D2	D1	LSB D0
Advanced Switch Time of Mute	0.6msec							0	0
	1.0msec							0	1
	1.4msec							1	0
	3.2msec							1	1
Hi-voltage ON/OFF	OFF						0		
	ON						1		
Level Shift	0dB					0			
	+3dB					1			
Advanced Switch Time of Volume /Fader /Tone/Loudness	4.7msec			0	0				
	7.2msec			0	1				
	11.2msec			1	0				
	14.4msec			1	1				
Anti Alias Filter ON/OFF	OFF		0						
	ON		1						
Advanced Switch ON/OFF	OFF	0							
	ON	1							

Select address 02(hex) Default:8'h00

Function Name	Mode	LPF Setup								
		MSB D7	D6	D5	D4	D3	D2	D1	LSB D0	
Subwoofer LPF fc	55Hz						0	0	0	
	85Hz						0	0	1	
	120Hz						0	1	0	
	160Hz						0	1	1	
	PASS						1	0	0	
	Prohibition							1	0	1
								1	1	0
Subwoofer Input Selector1	Loudness					0				
	Input Selector					1				
Subwoofer Output Selector	Subwoofer 1ch(S1/S1)			0	0					
	Front(F1/F2)			0	1					
	Rear(R1/R2)			1	0					
Level Meter Reset (*1)	Subwoofer(S1/ S2)			1	1					
	Hold		0							
LPF Phase 0°/180°(*2)	Reset		1							
	0°	0								
	180°	1								

 : Initial condition

- (*1): If "Level Meter Reset" is set as Reset("b1), a reset pulse will be outputted only once to a level meter block. Also about this register, after a reset pulse output returns to a Hold("b0) state, without holding a Reset("b1) state. Therefore, in order to change into a Hold state, it is not necessary to carry out a register setup again.
- (*2): If Subwoofer LPF fc is set as 「PASS」 ("b000), LPF PHASE is compulsorily fixed to 0°("b0).

Select address 03(hex)

Default:8'h01

Function Name	Mode				Pin			MSB			Initial Setup2			LSB
					1p	1n	2n	2p	D7	D6	D5	D4	D3	D2
Level Meter ON/OFF(*1)	Output Level Detector Mode													0
	Level Meter Mode													1
Loudness f0	400Hz									0	0			
	800Hz									0	1			
	2400Hz									1	0			
	Prohibition									1	1			
Mixing Input Selector (*2)	Mix	MIN_EN2	-		MIN_EN2	0	0	0						
	Prohibition					0	0	1						
	A_Single	A1	-		A2	0	1	0						
	D_Diff	DP1	DN		DP2	0	1	1						
	B_Single	B1	-		B2	1	0	0						
	E_Diff	EP1	EN1		EP2	1	0	1						
	E_Full-diff	EP1	EN1	MIN_EN2	EP2	1	1	0						
Prohibition					1	1	1							

(*1): When you use "Output level detector", please set this register of D0 as 0.
 Since "Level Meter" and "Output Level Detector" are sharing the terminal, concurrent use is impossible.
 Default setup is "Level Meter"

D0	16pin			17pin	
0	OLDC	Filter output terminal of output level detector		OLD	Output terminal of output level detector
1	LRST	Level meter reset terminal		LOUT	Output terminal for Level meter

(*2): When you set Mixing Input Selector as "Mix"('b000), please do not set input Selector(Select Address 05, D0 to D4) as "E_Full_Diff"('b 01000).
 When you set Mixing Input Selector as "E_Diff"('b101), please do not set input Selector(Select Address 05, D0 to D4) as "E_Full_Diff"('b 01000).
 When you set Mixing Input Selector as "E_Full_Diff"('b110), please do not set input Selector(Select Address 05, D0 to D4) as "E_Diff"('b 00111).

Select address 04(hex)

Default:8'h80

Function Name	Mode				MSB			HPF Setup			LSB	
					D7	D6	D5	D4	D3	D2	D1	D0
HPF fc	55Hz										0	0
	85Hz										0	1
	120Hz										1	0
	160Hz										1	1
Subwoofer Input Selector2	Subwoofer Input Selector1								0	0		
	LPF ON								0	1		
	HPF ON								1	0		
	Prohibition								1	1		
Front Input Selector	Loudness							0				
	HPF ON							1				
Rear Input Selector	Loudness						0					
	HPF ON						1					
1ch Mixing Input Selector	1ch					0						
	2ch					1						
2ch Mixing Input Selector	1ch				0							
	2ch				1							

 : Initial condition

Select address 05(hex)

Default:8'h00

Function Name	Mode	Pin				MSB			Initial Setup2					LSB
		1p	1n	2n	2p	D7	D6	D5	D4	D3	D2	D1	D0	
Input Selector (*1)	A_Single	A1	-	-	A2				0	0	0	0	0	
	B_Single	B1	-	-	B2				0	0	0	0	1	
	C_Single	C1	-	-	C2				0	0	0	1	0	
	D_Single	DP1	-	-	DP2				0	0	0	1	1	
	E1_Single	EP1	-	-	EN1				0	1	0	1	0	
	E2_Single	EN2	-	-	EP2				0	1	0	1	1	
	D_Diff	DP1	-	-	DP2				0	0	1	1	0	
	E_Diff	EP1	DN	EP2				0	0	1	1	1	1	
	E_Full_Diff	EP1	EN1	EP2				0	1	0	0	0	0	
	Prohibition Input short						Other setting							
Full-diff Type	Negative input				0									
	Bias				1									

(*1): There is combination which shares an input terminal depending on the combination of "Input Selector" (Select Address 05, D0 to D4) and "Mixing Input Selector" (Select Address 03, D5 to D7). Be careful not to set up the following combination.

Input Selector					Mixing Input Selector				
Mode	Pin				Mode	Pin			
	1p	1n	2n	2p		1p	1n	2n	2p
E_Full_Diff	EP1	EN1	MIN_EN2	EP2	Mix	MIN_EN2	-	-	MIN_EN2
E_Full_Diff	EP1	EN1	MIN_EN2	EP2	E_Diff	EP1	EN1		EP2
E_Diff	EP1	EN1		EP2	E_Full_Diff	EP1	EN1	MIN_EN2	EP2

Select address 06 (hex)

Default:8'ha0

Function Name	Gain	MSB			Input Selector					LSB
		D7	D6	D5	D4	D3	D2	D1	D0	
Input Gain	0dB				0	0	0	0	0	
	1dB				0	0	0	0	1	
	2dB				0	0	0	1	0	
	3dB				0	0	0	1	1	
	4dB				0	0	1	0	0	
	5dB				0	0	1	0	1	
	6dB				0	0	1	1	0	
	7dB				0	0	1	1	1	
	8dB				0	1	0	0	0	
	9dB				0	1	0	0	1	
	10dB				0	1	0	1	0	
	11dB				0	1	0	1	1	
	12dB				0	1	1	0	0	
	13dB				0	1	1	0	1	
	14dB				0	1	1	1	0	
	15dB				0	1	1	1	1	
	16dB				1	0	0	0	0	
	(16dB)				1	0	0	0	1	
(16dB)				1	0	0	1	0		
(16dB)				1	0	0	1	1		
(16dB)				1	0	1	0	0		
Prohibition		Other setting								
Mute ON/OFF	OFF	0								
	ON	1								

: Initial condition

Select address 20 (hex) Default:8'h00

Function Name	Mode	Volume Gain							
		MSB D7	D6	D5	D4	D3	D2	D1	LSB D0
Volume Gain	Prohibition	0	0	0	0	0	0	0	0
		⋮	⋮	⋮	⋮	⋮	⋮	⋮	⋮
		0	1	1	1	0	0	0	0
	+15dB	0	1	1	1	0	0	0	1
	+14dB	0	1	1	1	0	0	1	0
	+13dB	0	1	1	1	0	0	1	1
	+12dB	0	1	1	1	0	1	0	0
	+11dB	0	1	1	1	0	1	0	1
	+10dB	0	1	1	1	0	1	1	0
	+9dB	0	1	1	1	0	1	1	1
	+8dB	0	1	1	1	1	0	0	0
	+7dB	0	1	1	1	1	0	0	1
	+6dB	0	1	1	1	1	0	1	0
	+5dB	0	1	1	1	1	0	1	1
	+4dB	0	1	1	1	1	1	0	0
	+3dB	0	1	1	1	1	1	0	1
	+2dB	0	1	1	1	1	1	1	0
	+1dB	0	1	1	1	1	1	1	1
	-0dB	1	0	0	0	0	0	0	0
	-1dB	1	0	0	0	0	0	0	1
	-2dB	1	0	0	0	0	0	1	0
	-3dB	1	0	0	0	0	0	1	1
	-4dB	1	0	0	0	0	1	0	0
	-5dB	1	0	0	0	0	1	0	1
	-6dB	1	0	0	0	0	1	1	0
	-7dB	1	0	0	0	0	1	1	1
	-8dB	1	0	0	0	1	0	0	0
	-9dB	1	0	0	0	1	0	0	1
	-10dB	1	0	0	0	1	0	1	0
	-11dB	1	0	0	0	1	0	1	1
-12dB	1	0	0	0	1	1	0	0	
-13dB	1	0	0	0	1	1	0	1	
-14dB	1	0	0	0	1	1	1	0	
-15dB	1	0	0	0	1	1	1	1	
-16dB	1	0	0	1	0	0	0	0	
-17dB	1	0	0	1	0	0	0	1	
-18dB	1	0	0	1	0	0	1	0	
-19dB	1	0	0	1	0	0	1	1	
-20dB	1	0	0	1	0	1	0	0	

 : Initial condition

Function Name	Mode	Volume Gain							
		MSB D7	D6	D5	D4	D3	D2	D1	LSB D0
Volume Gain	-21dB	1	0	0	1	0	1	0	1
	-22dB	1	0	0	1	0	1	1	0
	-23dB	1	0	0	1	0	1	1	1
	-24dB	1	0	0	1	1	0	0	0
	-25dB	1	0	0	1	1	0	0	1
	-26dB	1	0	0	1	1	0	1	0
	-27dB	1	0	0	1	1	0	1	1
	-28dB	1	0	0	1	1	1	0	0
	-29dB	1	0	0	1	1	1	0	1
	-30dB	1	0	0	1	1	1	1	0
	-31dB	1	0	0	1	1	1	1	1
	-32dB	1	0	1	0	0	0	0	0
	-33dB	1	0	1	0	0	0	0	1
	-34dB	1	0	1	0	0	0	1	0
	-35dB	1	0	1	0	0	0	1	1
	-36dB	1	0	1	0	0	1	0	0
	-37dB	1	0	1	0	0	1	0	1
	-38dB	1	0	1	0	0	1	1	0
	-39dB	1	0	1	0	0	1	1	1
	-40dB	1	0	1	0	1	0	0	0
	-41dB	1	0	1	0	1	0	0	1
	-42dB	1	0	1	0	1	0	1	0
	-43dB	1	0	1	0	1	0	1	1
	-44dB	1	0	1	0	1	1	0	0
	-45dB	1	0	1	0	1	1	0	1
	-46dB	1	0	1	0	1	1	1	0
	-47dB	1	0	1	0	1	1	1	1
	-48dB	1	0	1	1	0	0	0	0
	-49dB	1	0	1	1	0	0	0	1
	-50dB	1	0	1	1	0	0	1	0
	-51dB	1	0	1	1	0	0	1	1
	-52dB	1	0	1	1	0	1	0	0
-53dB	1	0	1	1	0	1	0	1	
-54dB	1	0	1	1	0	1	1	0	
-55dB	1	0	1	1	0	1	1	1	
-56dB	1	0	1	1	1	0	0	0	
-57dB	1	0	1	1	1	0	0	1	
-58dB	1	0	1	1	1	0	1	0	
-59dB	1	0	1	1	1	0	1	1	
-60dB	1	0	1	1	1	1	0	0	
-61dB	1	0	1	1	1	1	0	1	
-62dB	1	0	1	1	1	1	1	0	
-63dB	1	0	1	1	1	1	1	1	
-64dB	1	1	0	0	0	0	0	0	
-65dB	1	1	0	0	0	0	0	1	
-66dB	1	1	0	0	0	0	1	0	
-67dB	1	1	0	0	0	0	1	1	
-68dB	1	1	0	0	0	1	0	0	
-69dB	1	1	0	0	0	1	0	1	
-70dB	1	1	0	0	0	1	1	0	

Function Name	Mode	MSB			Volume Gain				LSB	
		D7	D6	D5	D4	D3	D2	D1	D0	
Volume Gain	-71dB	1	1	0	0	0	1	1	1	
	-72dB	1	1	0	0	1	0	0	0	
	-73dB	1	1	0	0	1	0	0	1	
	-74dB	1	1	0	0	1	0	1	0	
	-75dB	1	1	0	0	1	0	1	1	
	-76dB	1	1	0	0	1	1	0	0	
	-77dB	1	1	0	0	1	1	0	1	
	-78dB	1	1	0	0	1	1	1	0	
	-79dB	1	1	0	0	1	1	1	1	
	Prohibition	∴	∴	∴	∴	∴	∴	∴	∴	
∴	∴	∴	∴	∴	∴	∴	∴	∴		
-79dB	1	1	1	1	1	1	1	1		

Select address 28, 29, 2A, 2B, 2C, 2D, 30, 31(hex) Default:8'hFF

Function Name	Mode	MSB			Fader / Mixing Gain				LSB	
		D7	D6	D5	D4	D3	D2	D1	D0	
Fader/Mixing Gain	Prohibition	0	0	0	0	0	0	0	0	
		∴	∴	∴	∴	∴	∴	∴	∴	
		0	1	1	1	0	0	0	0	
	+15dB	0	1	1	1	0	0	0	1	
	+14dB	0	1	1	1	0	0	1	0	
	+13dB	0	1	1	1	0	0	1	1	
	+12dB	0	1	1	1	0	1	0	0	
	+11dB	0	1	1	1	0	1	0	1	
	+10dB	0	1	1	1	0	1	1	0	
	+9dB	0	1	1	1	0	1	1	1	
	+8dB	0	1	1	1	1	0	0	0	
	+7dB	0	1	1	1	1	0	0	1	
	+6dB	0	1	1	1	1	0	1	0	
	+5dB	0	1	1	1	1	0	1	1	
	+4dB	0	1	1	1	1	1	0	0	
	+3dB	0	1	1	1	1	1	0	1	
	+2dB	0	1	1	1	1	1	1	0	
+1dB	0	1	1	1	1	1	1	1		

Function Name	Mode	Fader Gain							
		MSB D7	D6	D5	D4	D3	D2	D1	LSB D0
Fader/Mixing Gain	-0dB	1	0	0	0	0	0	0	0
	-1dB	1	0	0	0	0	0	0	1
	-2dB	1	0	0	0	0	0	1	0
	-3dB	1	0	0	0	0	0	1	1
	-4dB	1	0	0	0	0	1	0	0
	-5dB	1	0	0	0	0	1	0	1
	-6dB	1	0	0	0	0	1	1	0
	-7dB	1	0	0	0	0	1	1	1
	-8dB	1	0	0	0	1	0	0	0
	-9dB	1	0	0	0	1	0	0	1
	-10dB	1	0	0	0	1	0	1	0
	-11dB	1	0	0	0	1	0	1	1
	-12dB	1	0	0	0	1	1	0	0
	-13dB	1	0	0	0	1	1	0	1
	-14dB	1	0	0	0	1	1	1	0
	-15dB	1	0	0	0	1	1	1	1
	-16dB	1	0	0	1	0	0	0	0
	-17dB	1	0	0	1	0	0	0	1
	-18dB	1	0	0	1	0	0	1	0
	-19dB	1	0	0	1	0	0	1	1
	-20dB	1	0	0	1	0	1	0	0
	-21dB	1	0	0	1	0	1	0	1
	-22dB	1	0	0	1	0	1	1	0
	-23dB	1	0	0	1	0	1	1	1
	-24dB	1	0	0	1	1	0	0	0
	-25dB	1	0	0	1	1	0	0	1
	-26dB	1	0	0	1	1	0	1	0
	-27dB	1	0	0	1	1	0	1	1
	-28dB	1	0	0	1	1	1	0	0
	-29dB	1	0	0	1	1	1	0	1
	-30dB	1	0	0	1	1	1	1	0
	-31dB	1	0	0	1	1	1	1	1
	-32dB	1	0	1	0	0	0	0	0
	-33dB	1	0	1	0	0	0	0	1
	-34dB	1	0	1	0	0	0	1	0
	-35dB	1	0	1	0	0	0	1	1
	-36dB	1	0	1	0	0	1	0	0
	-37dB	1	0	1	0	0	1	0	1
	-38dB	1	0	1	0	0	1	1	0
	-39dB	1	0	1	0	0	1	1	1
-40dB	1	0	1	0	1	0	0	0	

Function Name	Mode	MSB		Fader Gain				LSB	
		D7	D6	D5	D4	D3	D2	D1	D0
Fader/Mixing Gain	-41dB	1	0	1	0	1	0	0	1
	-42dB	1	0	1	0	1	0	1	0
	-43dB	1	0	1	0	1	0	1	1
	-44dB	1	0	1	0	1	1	0	0
	-45dB	1	0	1	0	1	1	0	1
	-46dB	1	0	1	0	1	1	1	0
	-47dB	1	0	1	0	1	1	1	1
	-48dB	1	0	1	1	0	0	0	0
	-49dB	1	0	1	1	0	0	0	1
	-50dB	1	0	1	1	0	0	1	0
	-51dB	1	0	1	1	0	0	1	1
	-52dB	1	0	1	1	0	1	0	0
	-53dB	1	0	1	1	0	1	0	1
	-54dB	1	0	1	1	0	1	1	0
	-55dB	1	0	1	1	0	1	1	1
	-56dB	1	0	1	1	1	0	0	0
	-57dB	1	0	1	1	1	0	0	1
	-58dB	1	0	1	1	1	0	1	0
	-59dB	1	0	1	1	1	0	1	1
	-60dB	1	0	1	1	1	1	0	0
	-61dB	1	0	1	1	1	1	0	1
	-62dB	1	0	1	1	1	1	1	0
	-63dB	1	0	1	1	1	1	1	1
	-64dB	1	1	0	0	0	0	0	0
	-65dB	1	1	0	0	0	0	0	1
	-66dB	1	1	0	0	0	0	1	0
	-67dB	1	1	0	0	0	0	1	1
	-68dB	1	1	0	0	0	1	0	0
	-69dB	1	1	0	0	0	1	0	1
	-70dB	1	1	0	0	0	1	1	0
-71dB	1	1	0	0	0	1	1	1	
-72dB	1	1	0	0	1	0	0	0	
-73dB	1	1	0	0	1	0	0	1	
-74dB	1	1	0	0	1	0	1	0	
-75dB	1	1	0	0	1	0	1	1	
-76dB	1	1	0	0	1	1	0	0	
-77dB	1	1	0	0	1	1	0	1	
-78dB	1	1	0	0	1	1	1	0	
-79dB	1	1	0	0	1	1	1	1	
Prohibition	∴	∴	∴	∴	∴	∴	∴	∴	
MUTE	1	1	1	1	1	1	1	1	

 : Initial condition

Select address 41(hex) Default:8'h00

Function Name	Mode	MSB								
		D7	D6	D5	D4	D3	D2	D1	D0	
Bass Q	0.5								0	0
	1.0								0	1
	1.5								1	0
	2.0								1	1
Bass f0	60Hz			0	0					
	80Hz			0	1					
	100Hz			1	0					
	120Hz			1	1					

Select address 44(hex) Default:8'h00

Function Name	Mode	MSB								
		D7	D6	D5	D4	D3	D2	D1	D0	
Middle Q	0.75								0	0
	1.00								0	1
	1.25								1	0
	1.50								1	1
Middle f0	0.5kHz			0	0					
	1kHz			0	1					
	1.5kHz			1	0					
	2.5kHz			1	1					

Select address 47(hex) Default:8'h00

Function Name	Mode	MSB								
		D7	D6	D5	D4	D3	D2	D1	D0	
Treble Q	0.75									0
	1.25									1
Treble f0	7.5kHz			0	0					
	10kHz			0	1					
	12.5kHz			1	0					
	15kHz			1	1					

 : Initial condition

Select address 51, 54, 57(hex) Default:8'h80

Function Name	Mode	MSB			Bass/Middle/Treble Gain					LSB
		D7	D6	D5	D4	D3	D2	D1	D0	
Bass /Middle /Treble Gain	0dB				0	0	0	0	0	
	1dB				0	0	0	0	1	
	2dB				0	0	0	1	0	
	3dB				0	0	0	1	1	
	4dB				0	0	1	0	0	
	5dB				0	0	1	0	1	
	6dB				0	0	1	1	0	
	7dB				0	0	1	1	1	
	8dB				0	1	0	0	0	
	9dB				0	1	0	0	1	
	10dB				0	1	0	1	0	
	11dB				0	1	0	1	1	
	12dB				0	1	1	0	0	
	13dB				0	1	1	0	1	
	14dB				0	1	1	1	0	
	15dB				0	1	1	1	1	
	(15dB)				1	0	0	0	0	
	(15dB)				1	0	0	0	1	
	(15dB)				1	0	0	1	0	
	(15dB)				1	0	0	1	1	
(15dB)				1	0	1	0	0		
Prohibition				other setting						
Bass/Middle/Treble Boost/Cut	Boost	0								
	Cut	1								

Select address 75(hex) Default:8'h00

Function Name	Mode	MSB			Loudness Gain					LSB
		D7	D6	D5	D4	D3	D2	D1	D0	
Loudness Gain	0dB				0	0	0	0	0	
	1dB				0	0	0	0	1	
	2dB				0	0	0	1	0	
	3dB				0	0	0	1	1	
	4dB				0	0	1	0	0	
	5dB				0	0	1	0	1	
	6dB				0	0	1	1	0	
	7dB				0	0	1	1	1	
	8dB				0	1	0	0	0	
	9dB				0	1	0	0	1	
	10dB				0	1	0	1	0	
	11dB				0	1	0	1	1	
	12dB				0	1	1	0	0	
	13dB				0	1	1	0	1	
	14dB				0	1	1	1	0	
	15dB				0	1	1	1	1	
	(15dB)				1	0	0	0	0	
	(15dB)				1	0	0	0	1	
	(15dB)				1	0	0	1	0	
	(15dB)				1	0	0	1	1	
(15dB)				1	0	1	0	0		
Prohibition				other setting						
Loudness HICUT	HICUT1		0	0						
	HICUT2		0	1						
	HICUT3		1	0						
	HICUT4		1	1						

 : Initial condition

Select address 90(hex) Default:8'h00

Function Name	Mode	Output Level Detector							
		MSB						LSB	
		D7	D6	D5	D4	D3	D2	D1	D0
OUT R2 ON/OFF	OFF								0
	ON								1
OUT R1 ON/OFF	OFF							0	
	ON							1	
OUT F2 ON/OFF	OFF						0		
	ON						1		
OUT F1 ON/OFF	OFF					0			
	ON					1			
Threshold Level Select	±30mV			0	0				
	±45mV			0	1				
	±60mV			1	0				
	±75mV			1	1				

: Initial condition

Recommendation of VOLUME DIAGRAM

The example of the SET VOLUME DIAGRAM by Volume(SelectAddress 20(hex)) and Fader(SelectAddress 28,29,2A,2B,2C, 2D(hex)) is explained in the following.

Example 1) It is recommended when a signal level is made to attenuate, a decline by Volume is done by -24dB. It is adjusted with Fader after -24dB. S/N ratio can improve in comparison with the case that it is made to attenuate only with Volume.

Display (※)	Total Gain [dB]	Volume [dB]	Fader [dB]
50	6	6	0
49	5	5	0
48	4	4	0
47	3	3	0
46	2	2	0
45	1	1	0
44	0	0	0
43	-1	-1	0
42	-2	-2	0
41	-3	-3	0
40	-4	-4	0
39	-5	-5	0
38	-6	-6	0
37	-7	-7	0
36	-8	-8	0
35	-9	-9	0
34	-10	-10	0
33	-11	-11	0
32	-12	-12	0
31	-13	-13	0
30	-14	-14	0
29	-15	-15	0
28	-16	-16	0
27	-17	-17	0
26	-18	-18	0

Display (※)	Total Gain [dB]	Volume [dB]	Fader [dB]
25	-19	-19	0
24	-20	-20	0
23	-21	-21	0
22	-22	-22	0
21	-23	-23	0
20	-24	-24	0
19	-26	-24	-2
18	-28	-24	-4
17	-30	-24	-6
16	-32	-24	-8
15	-34	-24	-10
14	-36	-24	-12
13	-38	-24	-14
12	-40	-24	-16
11	-42	-24	-18
10	-44	-24	-20
9	-46	-24	-22
8	-48	-24	-24
7	-50	-24	-26
6	-52	-24	-28
5	-54	-24	-30
4	-56	-24	-32
3	-58	-24	-34
2	-60	-24	-36
1	-62	-24	-38
0	-∞	Mute	Mute

Table 1. A decline by Volume is done by -24dB. It is adjusted with Fader after -24dB.
(※Display=SET VOLUME)