



Chipsmall Limited consists of a professional team with an average of over 10 year of expertise in the distribution of electronic components. Based in Hongkong, we have already established firm and mutual-benefit business relationships with customers from,Europe,America and south Asia,supplying obsolete and hard-to-find components to meet their specific needs.

With the principle of “Quality Parts,Customers Priority,Honest Operation,and Considerate Service”,our business mainly focus on the distribution of electronic components. Line cards we deal with include Microchip,ALPS,ROHM,Xilinx,Pulse,ON,Everlight and Freescale. Main products comprise IC,Modules,Potentiometer,IC Socket,Relay,Connector.Our parts cover such applications as commercial,industrial, and automotives areas.

We are looking forward to setting up business relationship with you and hope to provide you with the best service and solution. Let us make a better world for our industry!



## Contact us

Tel: +86-755-8981 8866 Fax: +86-755-8427 6832

Email & Skype: info@chipsmall.com Web: www.chipsmall.com

Address: A1208, Overseas Decoration Building, #122 Zhenhua RD., Futian, Shenzhen, China





# BD533 BD535 BD537 BD534 BD536

## Complementary power transistors

### Features

- BD533, BD535, and BD537 are NPN transistors

### Description

The devices are manufactured in Planar technology with “Base Island” layout. The resulting transistor shows exceptional high gain performance coupled with very low saturation voltage. The PNP types are BD534 and BD536.

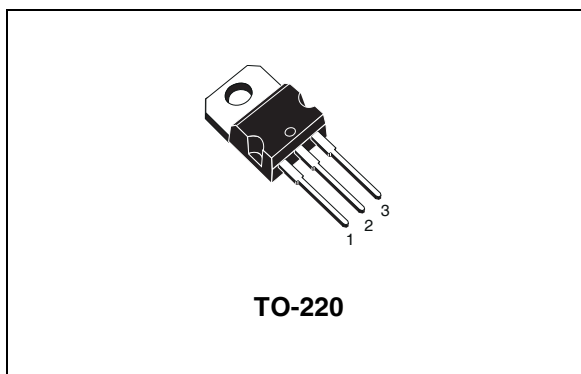


Figure 1. Internal schematic diagrams

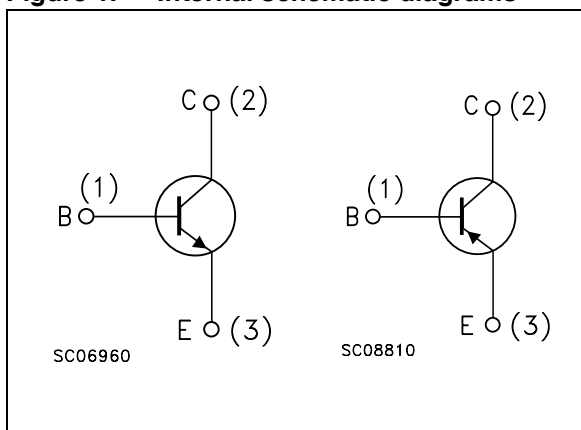


Table 1. Device summary

Order code	Marking	Package	Packaging
BD533	BD533	TO-220	Tube
BD534	BD534		
BD535	BD535		
BD536	BD536		
BD537	BD537		

# 1 Absolute maximum ratings

**Table 2. Absolute maximum ratings**

Symbol	Parameter	Value			Unit	
		NPN	BD533	BD535		BD537
		PNP	BD534	BD536		
$V_{CBO}$	Collector-base voltage ( $I_E = 0$ )	45	60	80	V	
$V_{CES}$	Collector-emitter voltage ( $V_B = 0$ )	45	60	80	V	
$V_{CEO}$	Collector-base voltage ( $I_B = 0$ )	45	60	80	V	
$V_{EBO}$	Emitter-base voltage ( $I_C = 0$ )	5			V	
$I_C$	Collector current	8			A	
$I_B$	Base current	1			A	
$P_{TOT}$	Total dissipation at $T_{case} = 25^\circ\text{C}$	50			W	
$T_{stg}$	Storage temperature	-65 to 150			$^\circ\text{C}$	
$T_J$	Max. operating junction temperature	150			$^\circ\text{C}$	

*Note:* For PNP types voltage and current values are negative

**Table 3. Electrical characteristics**(T<sub>case</sub> = 25°C; unless otherwise specified)**Table 4. Electrical characteristics**

Symbol	Parameter	Test Conditions	Min.	Typ.	Max.	Unit
I <sub>CBO</sub>	Collector cut-off current (I <sub>E</sub> = 0)	V <sub>CB</sub> = rated V <sub>CBO</sub>			0.1	mA
I <sub>CES</sub>	Collector cut-off current (V <sub>BE</sub> = 0)	for BD533/534 V <sub>CE</sub> = 45 V for BD535/536 V <sub>CE</sub> = 60 V for BD537 V <sub>CE</sub> = 80 V			0.1 0.1 0.1	mA mA mA
I <sub>EBO</sub>	Emitter cut-off current (I <sub>C</sub> = 0)	V <sub>EB</sub> = 5V			1	mA
V <sub>CEO(sus)</sub> <sup>(1)</sup>	Collector-emitter sustaining voltage (I <sub>B</sub> = 0)	I <sub>C</sub> = 100mA for BD533/534 for BD535/536 for BD537	45 60 80			V V V
V <sub>CE(sat)</sub> <sup>(1)</sup>	Collector-emitter saturation voltage	I <sub>C</sub> = 2A I <sub>B</sub> = 0.2A I <sub>C</sub> = 6A I <sub>B</sub> = 0.6A		0.8	0.8	V V
V <sub>BE</sub> <sup>(1)</sup>	Base-emitter voltage	I <sub>C</sub> = 2A V <sub>CE</sub> = 2V			1.5	V
h <sub>FE</sub> <sup>(1)</sup>	DC current gain	I <sub>C</sub> = 10mA V <sub>CE</sub> = 5V for BD533/534 for BD535/536 for BD537 I <sub>C</sub> = 500mA V <sub>CE</sub> = 2V I <sub>C</sub> = 2A V <sub>CE</sub> = 2V for BD533/534 for BD535/536 for BD537	20 20 15 40 25 25 15			

1. Pulsed duration = 300 ms, duty cycle ≥1.5%.

**Note:** For PNP types voltage e current values are negative.

# 1.1 Electrical characteristic (curves)

Figure 2. Safe operating area

Figure 3. Derating curve

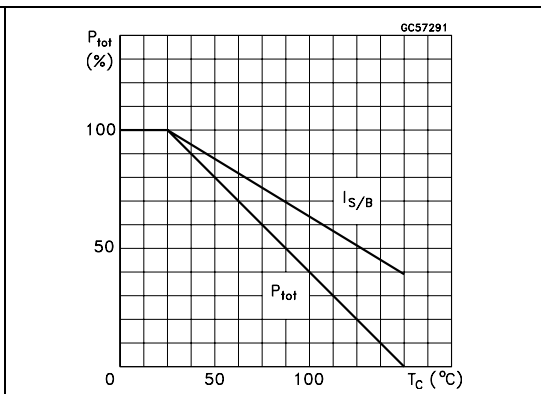
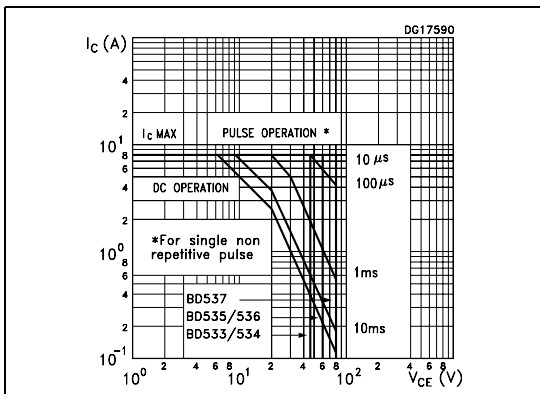


Figure 4. DC current gain (NPN)

Figure 5. DC current gain (PNP)

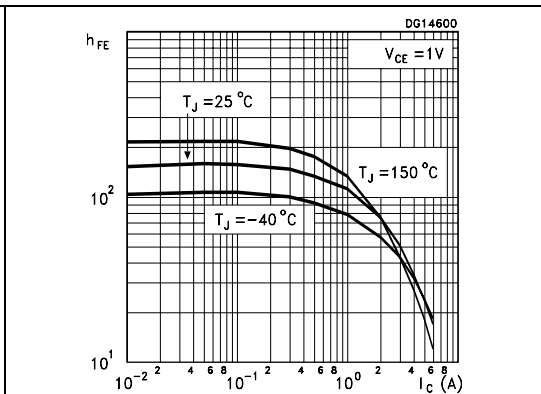
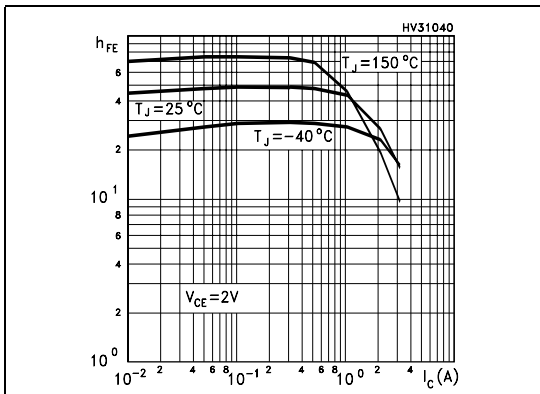
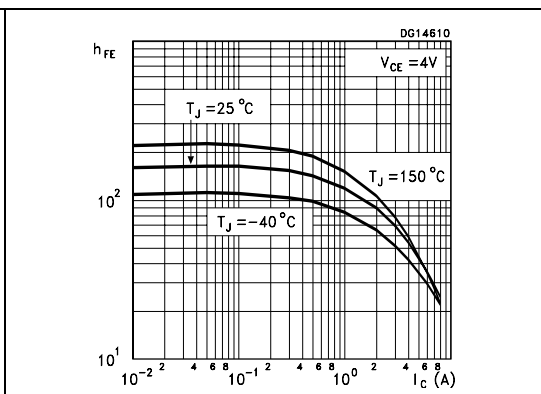
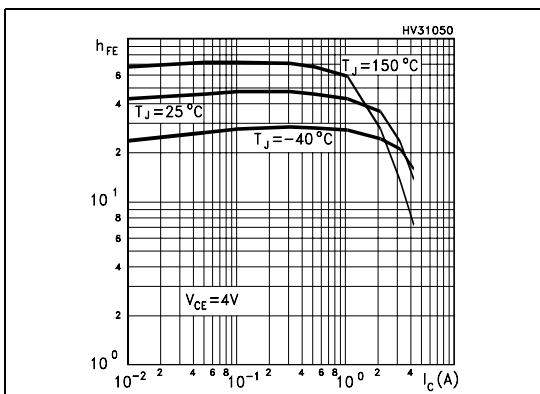


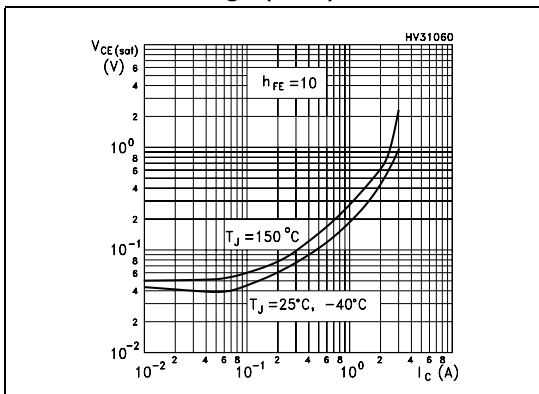
Figure 6. DC current gain (NPN)

Figure 7. DC current gain (PNP)

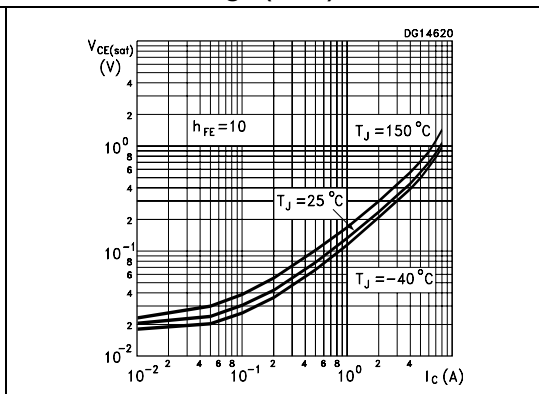




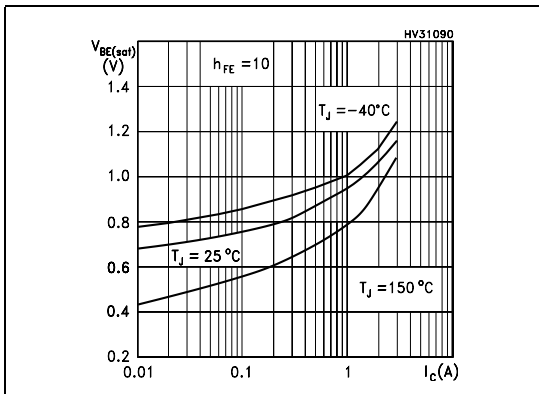
**Figure 8. Collector-emitter saturation voltage (NPN)**



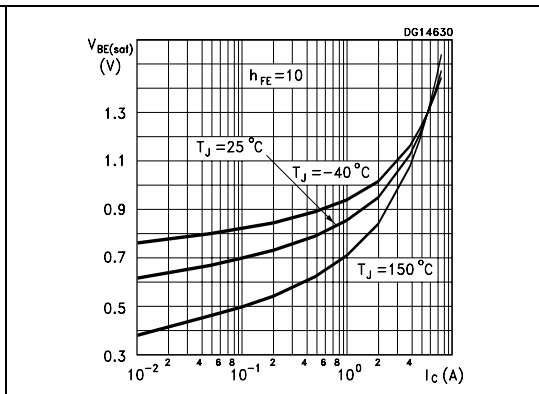
**Figure 9. Collector-emitter saturation voltage (PNP)**



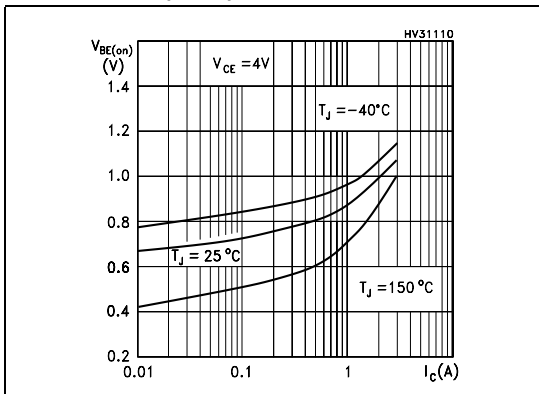
**Figure 10. Base-emitter saturation voltage (NPN)**



**Figure 11. Base-emitter saturation voltage (PNP)**



**Figure 12. Base-emitter on voltage (NPN)**



**Figure 13. Base-emitter on voltage (PNP)**

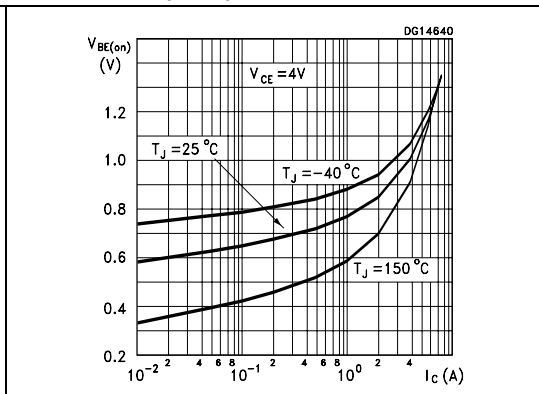


Figure 14. Resistive load switching time (NPN)      Figure 15. Resistive load switching time (PNP)

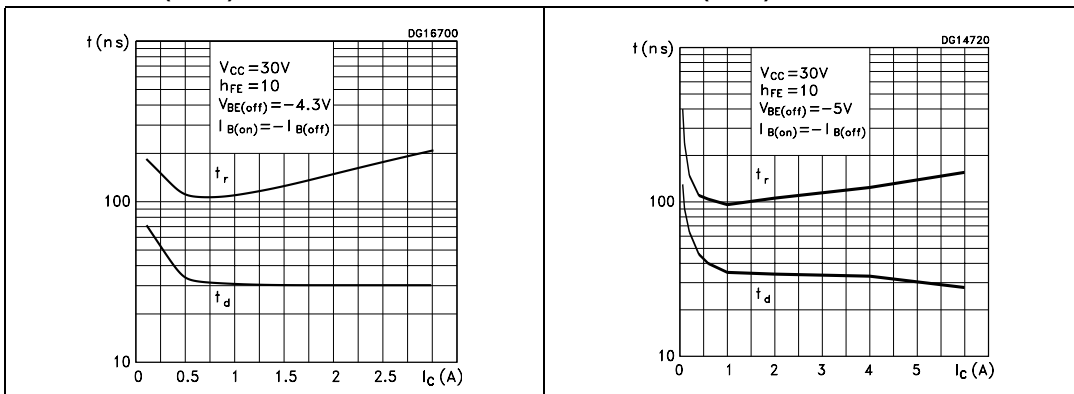


Figure 16. Resistive load switching time (NPN)      Figure 17. Resistive load switching time (PNP)

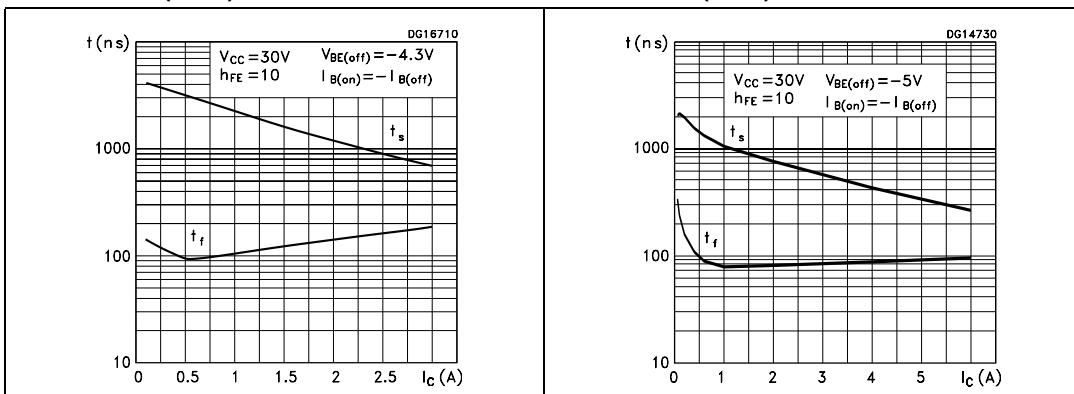
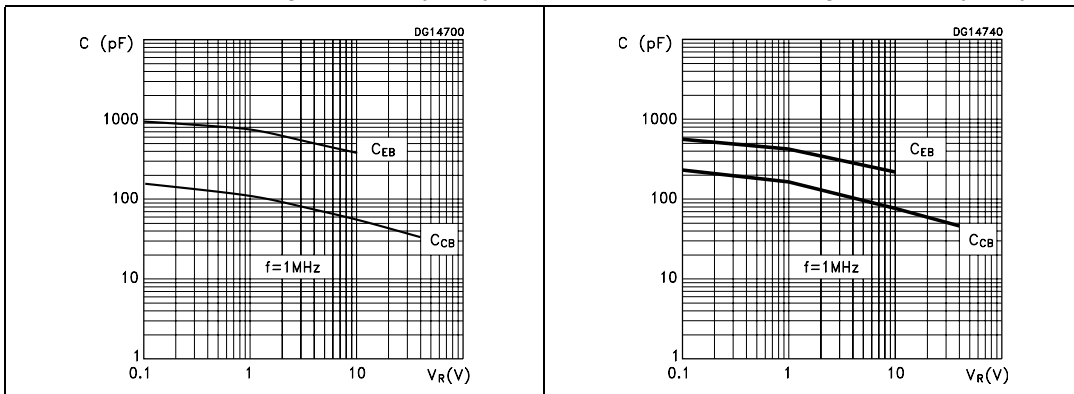
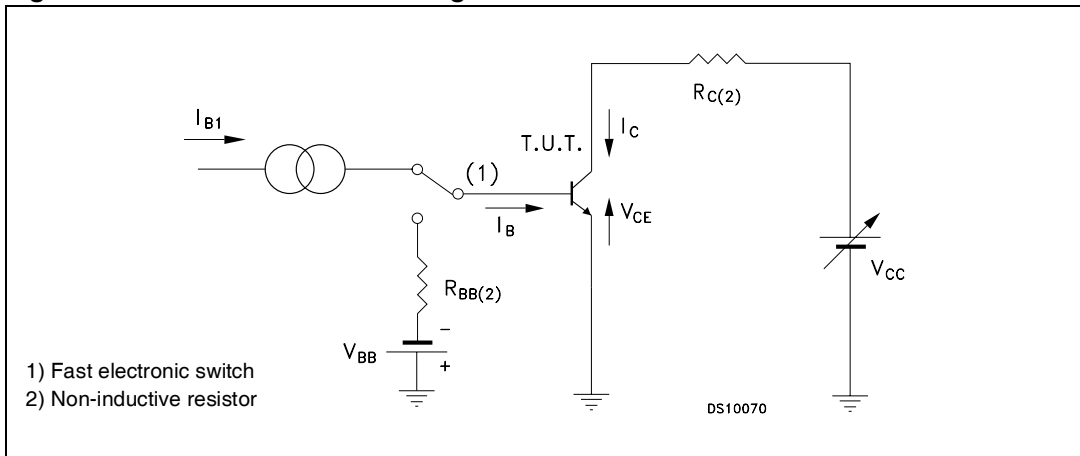


Figure 18. Collector-base and collector-emitter capacitance (NPN)      Figure 19. Collector-base and collector-emitter capacitance (PNP)



## 1.2 Test circuits

Figure 20. Resistive load switching test circuit



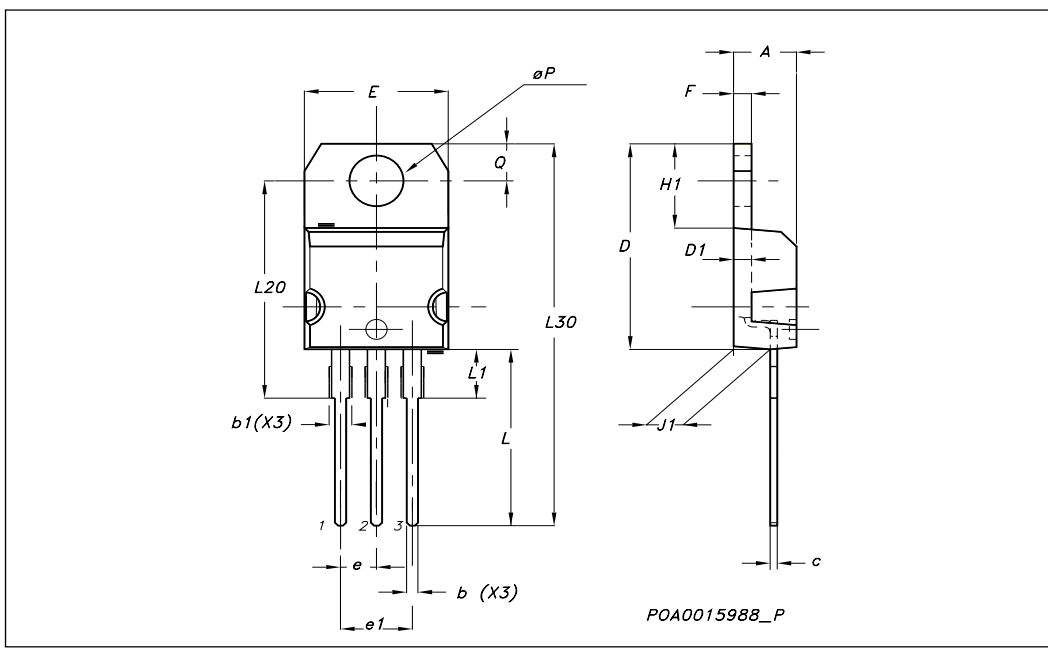


## 2 Package mechanical data

In order to meet environmental requirements, ST offers these devices in ECOPACK® packages. These packages have a Lead-free second level interconnect . The category of second level interconnect is marked on the package and on the inner box label, in compliance with JEDEC Standard JESD97. The maximum ratings related to soldering conditions are also marked on the inner box label. ECOPACK is an ST trademark. ECOPACK specifications are available at: [www.st.com](http://www.st.com)

**TO-220 Mechanical data**

DIM.	mm.		
	MIN.	TYP	MAX.
A	4.40		4.60
b	0.61		0.88
b1	1.14		1.70
c	0.49		0.70
D	15.25		15.75
D1		1.27	
E	10		10.40
e	2.40		2.70
e1	4.95		5.15
F	1.23		1.32
H1	6.20		6.60
J1	2.40		2.72
L	13		14
L1	3.50		3.93
L20		16.40	
L30		28.90	
øP	3.75		3.85
Q	2.65		2.95



### 3 Revision history

**Table 5. Revision history**

<b>Date</b>	<b>Revision</b>	<b>Changes</b>
01-Jun-1997	1	Initial Release
11-Feb-2003	2	Minor text changes
27-Mar-2007	3	Figure 4, 5, 6, 7, 8, 9, 10, 11, 12, 13, 14, 15, 16, 17, 18, 19 and figure 20 added
23-Jul-2007	4	Figure 2 and figure 3 added

**Please Read Carefully:**

Information in this document is provided solely in connection with ST products. STMicroelectronics NV and its subsidiaries ("ST") reserve the right to make changes, corrections, modifications or improvements, to this document, and the products and services described herein at any time, without notice.

All ST products are sold pursuant to ST's terms and conditions of sale.

Purchasers are solely responsible for the choice, selection and use of the ST products and services described herein, and ST assumes no liability whatsoever relating to the choice, selection or use of the ST products and services described herein.

No license, express or implied, by estoppel or otherwise, to any intellectual property rights is granted under this document. If any part of this document refers to any third party products or services it shall not be deemed a license grant by ST for the use of such third party products or services, or any intellectual property contained therein or considered as a warranty covering the use in any manner whatsoever of such third party products or services or any intellectual property contained therein.

**UNLESS OTHERWISE SET FORTH IN ST'S TERMS AND CONDITIONS OF SALE ST DISCLAIMS ANY EXPRESS OR IMPLIED WARRANTY WITH RESPECT TO THE USE AND/OR SALE OF ST PRODUCTS INCLUDING WITHOUT LIMITATION IMPLIED WARRANTIES OF MERCHANTABILITY, FITNESS FOR A PARTICULAR PURPOSE (AND THEIR EQUIVALENTS UNDER THE LAWS OF ANY JURISDICTION), OR INFRINGEMENT OF ANY PATENT, COPYRIGHT OR OTHER INTELLECTUAL PROPERTY RIGHT.**

**UNLESS EXPRESSLY APPROVED IN WRITING BY AN AUTHORIZED ST REPRESENTATIVE, ST PRODUCTS ARE NOT RECOMMENDED, AUTHORIZED OR WARRANTED FOR USE IN MILITARY, AIR CRAFT, SPACE, LIFE SAVING, OR LIFE SUSTAINING APPLICATIONS, NOR IN PRODUCTS OR SYSTEMS WHERE FAILURE OR MALFUNCTION MAY RESULT IN PERSONAL INJURY, DEATH, OR SEVERE PROPERTY OR ENVIRONMENTAL DAMAGE. ST PRODUCTS WHICH ARE NOT SPECIFIED AS "AUTOMOTIVE GRADE" MAY ONLY BE USED IN AUTOMOTIVE APPLICATIONS AT USER'S OWN RISK.**

Resale of ST products with provisions different from the statements and/or technical features set forth in this document shall immediately void any warranty granted by ST for the ST product or service described herein and shall not create or extend in any manner whatsoever, any liability of ST.

ST and the ST logo are trademarks or registered trademarks of ST in various countries.

Information in this document supersedes and replaces all information previously supplied.

The ST logo is a registered trademark of STMicroelectronics. All other names are the property of their respective owners.

© 2007 STMicroelectronics - All rights reserved

STMicroelectronics group of companies

Australia - Belgium - Brazil - Canada - China - Czech Republic - Finland - France - Germany - Hong Kong - India - Israel - Italy - Japan - Malaysia - Malta - Morocco - Singapore - Spain - Sweden - Switzerland - United Kingdom - United States of America

[www.st.com](http://www.st.com)

