



Chipsmall Limited consists of a professional team with an average of over 10 year of expertise in the distribution of electronic components. Based in Hongkong, we have already established firm and mutual-benefit business relationships with customers from,Europe,America and south Asia,supplying obsolete and hard-to-find components to meet their specific needs.

With the principle of “Quality Parts,Customers Priority,Honest Operation,and Considerate Service”,our business mainly focus on the distribution of electronic components. Line cards we deal with include Microchip,ALPS,ROHM,Xilinx,Pulse,ON,Everlight and Freescale. Main products comprise IC,Modules,Potentiometer,IC Socket,Relay,Connector.Our parts cover such applications as commercial,industrial, and automotives areas.

We are looking forward to setting up business relationship with you and hope to provide you with the best service and solution. Let us make a better world for our industry!



Contact us

Tel: +86-755-8981 8866 Fax: +86-755-8427 6832

Email & Skype: info@chipsmall.com Web: www.chipsmall.com

Address: A1208, Overseas Decoration Building, #122 Zhenhua RD., Futian, Shenzhen, China



Structure Silicon Monolithic Integrated Circuit

Product Name Synchronous rectification step-up DC/DC converter for mobile phone

Type **BD6069GUT**

Features Synchronous rectification step-up DC/DC converter
No external schottky diode required

○Absolute Maximum Ratings (Ta=25°C)

Parameter	Symbol	Rating	Unit	Condition
Maximum applied voltage1	VMAX1	7(*1)	V	VIN , EN , VFB , TEST
Maximum applied voltage2	VMAX2	20(*1)	V	SW , VOUT
Power dissipation	Pd	800(*2)	mW	
Operating temperature range	Topr	-30 to +85	°C	
Storage temperature range	Tstg	-55 to +150	°C	

(*1) These values are based on GND and GNDA pins.

(*2) This value is the measurement value that was mounted on the PCB by ROHM.
(50mm × 58mm × 1.75mm glass epoxy Board)
Temperature degrading: 6.4mW/°C from Ta>25°C

○Recommended operating conditions (Ta=-30 to +85°C)

Parameter	Symbol	Rating			Unit	Condition
		Min.	Typ.	Max.		
Supply voltage	Vin	2.7	3.6	5.5	V	

This product isn't designed to protect itself against radioactive rays.

Status of this document

The English version of this document is the formal specification.

A customer may use this translation version only for a reference to help reading the formal version.

If there are any differences in translation version of this document, formal version takes priority.

Application example

- ROHM cannot provide adequate confirmation of patents.
- The product described in this specification is designed to be used with ordinary electronic equipment or devices (such as audio-visual equipment, office-automation equipment, communications devices, electrical appliances, and electronic toys). Should you intend to use this product with equipment or devices which require an extremely high level of reliability and the malfunction of which would directly endanger human life (such as medical instruments, transportation equipment, aerospace machinery, nuclear-reactor controllers, fuel controllers and other safety devices), please be sure to consult with our sales representative in advance.
- ROHM assumes no responsibility for use of any circuits described herein, conveys no license under any patent or other right, and makes no representations that the circuits are free from patent infringement.

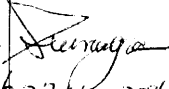
DESIGN	CHECK	APPROVAL	DATE	SPECIFICATION No.
Masaki Omi 27. Mar. 2006	Koji Taninuchi 27. Mar. 2006	 27. Mar. 2006	27/Mar/2006	TSZ02201-BD6069GUT-1-2
			REV. B	ROHM CO., LTD.

○Electrical Characteristics

(Unless otherwise noted, Ta = -30 to +85°C, Vin=3.6V)

Parameter	Symbol	Spec			Unit	Condition
		Min.	Typ.	Max.		
EN Terminal						
EN Low threshold voltage	VthL	-	-	0.4	V	
EN High threshold voltage	VthH	1.4	-	-	V	
EN Input current	Iin	-	18.3	30.0	μA	EN=5.5V
EN Output current	Iout	-2.0	-0.1	-	μA	EN=0
Switching Regulator						
Input voltage range	Vin	3.1	-	5.5	V	
Quiescent Current	Iq	-	0.1	2.0	μA	EN=0V
Current Consumption	Idd	-	1.1	1.5	mA	EN=2.6V,VFB=1.0V,VIN=3.6V
Feedback voltage	Vfb	0.47	0.50	0.53	V	
Inductor current limit	Icoil	270	350	430	mA	Vin=3.6V (*1)
SW saturation voltage	Vsat	-	0.14	0.28	V	Isw=200mA,Vin=3.6V
SW on resistance P	Ronp	-	2.1	3.2	Ω	Ipch=200mA,Vout=13V
Switching frequency	fSW	0.8	1.0	1.2	MHz	
Duty cycle limit	Duty	82.7	85.0	-	%	VFB=0V
Output voltage range	Vo	-	-	18.0	V	
Over voltage limit	Ovl	18.0	18.5	19.0	V	VFB=0V
Start up time	Ts	-	0.5	1.0	ms	

*1. This parameter is tested with dc measurement.

○External dimensions

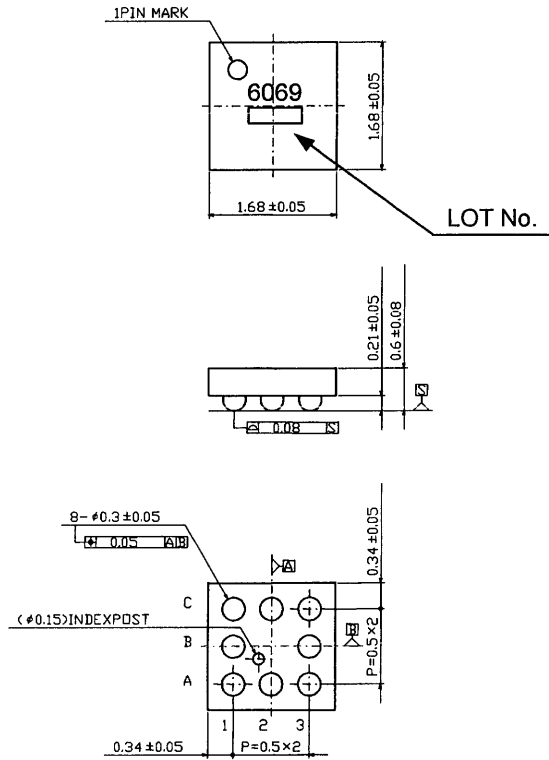

○Terminals

BALL	BALL Name
A1	GNDA
A2	EN
A3	TEST
B1	VIN
B3	VFB
C1	VOUT
C2	SW
C3	GND

VCSP60N1(8Pin) (Unit : mm)

○Block diagram

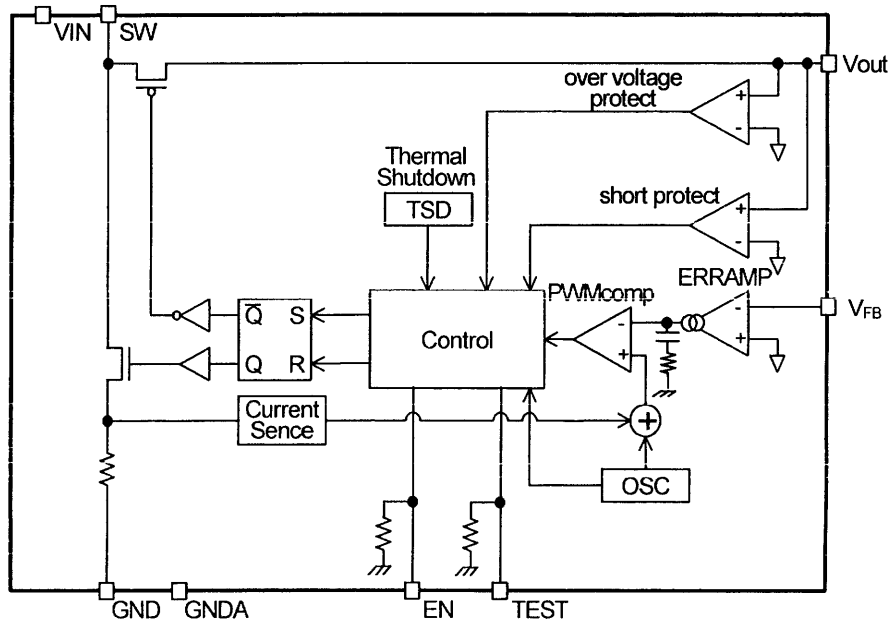

○ Cautions on use

(1) Absolute Maximum Ratings

An excess in the absolute maximum ratings, such as supply voltage, temperature range of operating conditions, etc., can break down devices, thus making impossible to identify breaking mode such as a short circuit or an open circuit. If any special mode exceeding the absolute maximum ratings is assumed, consideration should be given to take physical safety measures including the use of fuses, etc.

(2) Power supply and GND line

Design PCB pattern to provide low impedance for the wiring between the power supply and the GND lines. Pay attention to the interference by common impedance of layout pattern when there are plural power supplies and GND lines. Especially, when there are GND pattern for small signal and GND pattern for large current included the external circuits, please separate each GND pattern. Furthermore, for all power supply terminals to ICs, mount a capacitor between the power supply and the GND terminal. At the same time, in order to use a capacitor, thoroughly check to be sure the characteristics of the capacitor to be used present no problem including the occurrence of capacity dropout at a low temperature, thus determining the constant.

(3) GND voltage

Make setting of the potential of the GND terminal so that it will be maintained at the minimum in any operating state. Furthermore, check to be sure no terminals are at a potential lower than the GND voltage including an actual electric transient.

(4) Short circuit between terminals and erroneous mounting

In order to mount ICs on a set PCB, pay thorough attention to the direction and offset of the ICs. Erroneous mounting can break down the ICs. Furthermore, if a short circuit occurs due to foreign matters entering between terminals or between the terminal and the power supply or the GND terminal, the ICs can break down.

(5) Operation in strong electromagnetic field

Be noted that using ICs in the strong electromagnetic field can malfunction them.

(6) Input terminals

In terms of the construction of IC, parasitic elements are inevitably formed in relation to potential. The operation of the parasitic element can cause interference with circuit operation, thus resulting in a malfunction and then breakdown of the input terminal. Therefore, pay thorough attention not to handle the input terminals, such as to apply to the input terminals a voltage lower than the GND respectively, so that any parasitic element will operate. Furthermore, do not apply a voltage to the input terminals when no power supply voltage is applied to the IC. In addition, even if the power supply voltage is applied, apply to the input terminals a voltage lower than the power supply voltage or within the guaranteed value of electrical characteristics.

(7) External capacitor

In order to use a ceramic capacitor as the external capacitor, determine the constant with consideration given to a degradation in the nominal capacitance due to DC bias and changes in the capacitance due to temperature, etc.

(8) Thermal shutdown circuit (TSD)

When junction temperatures become 175°C (typ) or higher, the thermal shutdown circuit operates and turns a switch OFF. The thermal shutdown circuit, which is aimed at isolating the LSI from thermal runaway as much as possible, is not aimed at the protection or guarantee of the LSI. Therefore, do not continuously use the LSI with this circuit operating or use the LSI assuming its operation.

(9) Thermal design

Perform thermal design in which there are adequate margins by taking into account the permissible dissipation (Pd) in actual states of use.

(10) DC/DC converter

Please select the low DCR inductors to decrease power loss for DC/DC converter.

— Jisso Information —

Package : VCSP60N1

< A table of contents >

1. Structure and materials	1 / 4 page
2. Tape and Reel informations	1 / 4 ~ 3 / 4 page
3. Storage conditions	3 / 4 page
4. Marking lot number	3 / 4 page
5. Recommended soldering conditions	3 / 4 page
6. Footprint dimensions	4 / 4 page
7. Regarding the underfill material	4 / 4 page
8. External dimensions	4 / 4 page

1. Structure and materials

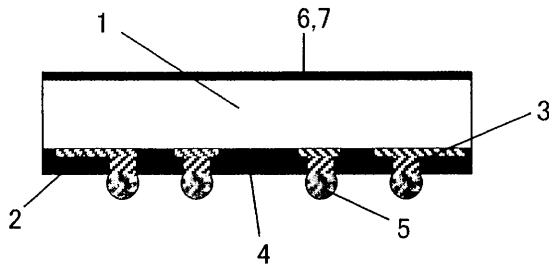

Fig. 1 Structure

No.	Item	Materials
①	Die	Silicon
②	Cu Layer	Cu
③	Cu Post	Cu
④	Encapsulation	Epoxy Resin
⑤	Ext. terminal	Sn-3Ag-0.5Cu Solder
⑥	Encapsulation	Polyamide-imide Resin
⑦	Marking	Laser Marking

Dehydrated weight : 0.003g

2. Tape and Reel information

2. 1. Packing specification

Tape	Embossed carrier tape
Quantity	3,000pcs/Reel
Direction of feed	E2 (See Fig. 2)

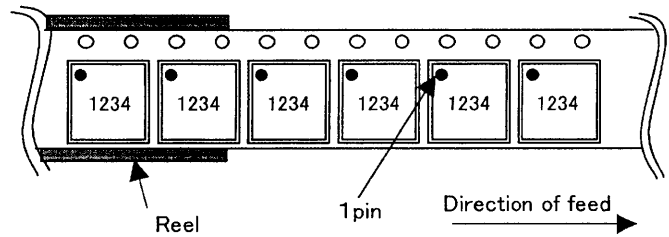

Fig. 2 Typical Tape and Reel configuration

2. 2. Tape and Reel specification

2. 2. 1. Tape and reel dimensions (See the table on page 2/4)

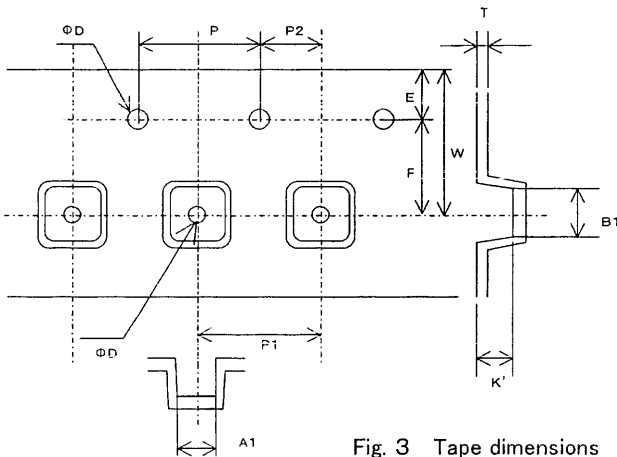

Fig. 3 Tape dimensions

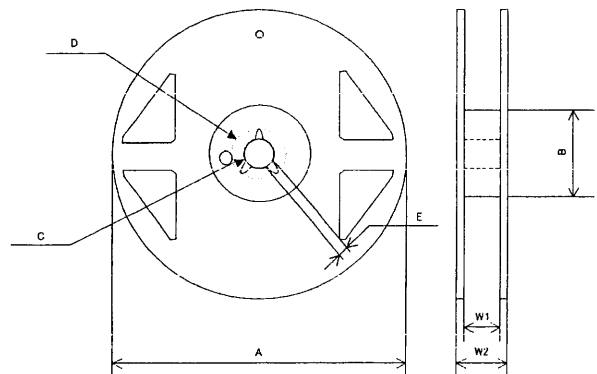

Fig. 4 Reel dimensions

DESIGN Masaki Omi 27-Mar-2006	CHECK Koji Taniuchi 27-Mar-2006	APPROVAL <i>[Signature]</i> 27-Mar-2006	DATE: 27/Mar/2006 REV. B	SPECIFICATION No. : TSZ02201-BD6069GUT-1-2 ROHM CO.,LTD.
--	--	---	-----------------------------	---

(Tape dimensions)

A1	B1	D0	D1	E	F	K'	P0	P1	P2	T	W
2.0 ±0.1	2.0 ±0.1	Φ1.5 +0.1 -0	Φ1.0 ±0.1	1.75 ±0.1	3.5 ±0.1	0.8 ±0.1	4.0 ±0.1	4.0 ±0.1	2.0 ±0.1	0.25 ±0.05	8.0 ±0.3

(Reel dimensions)

A	B	C	D	E	W1	W2
Φ180	50 MIN	13.0 ±0.2	20.2 MIN	1.5 MIN	9.4 ±1.0	13.4 ±1.0

2. 3. Leader and Trailer

2. 3. 1. Leader

No component pockets are 40 pockets or more.

2. 3. 2. Trailer

No component pockets are 10 pockets or more.

Tape is free from reel.

2. 4. Label for Reel and Box

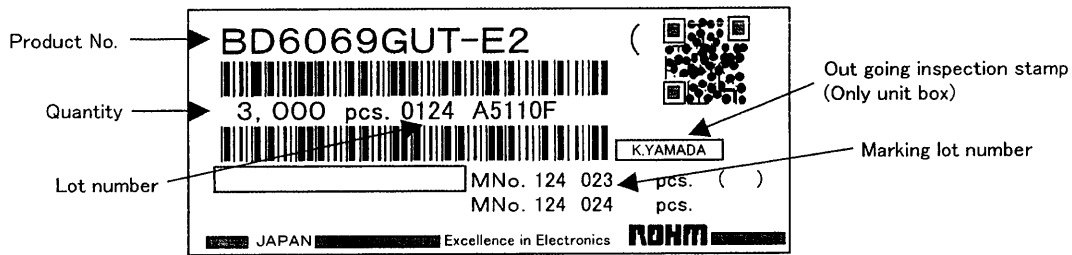

Fig. 5 Label example

2. 5. Packing style

4 reels or less per inner box.

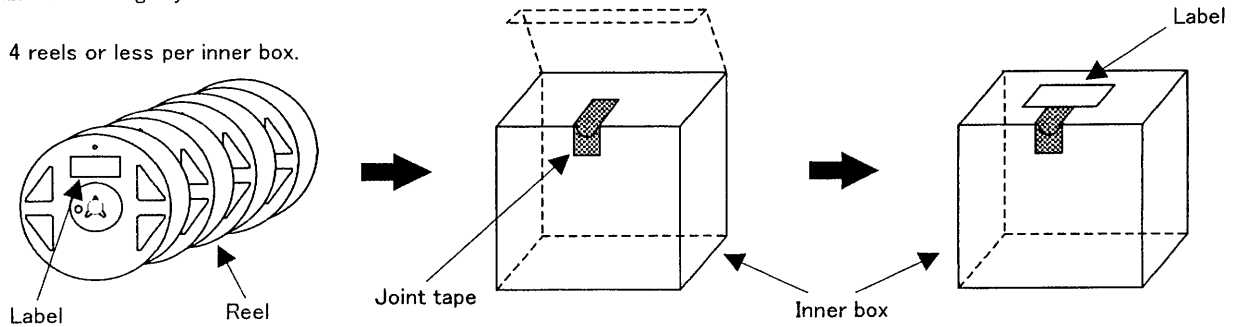
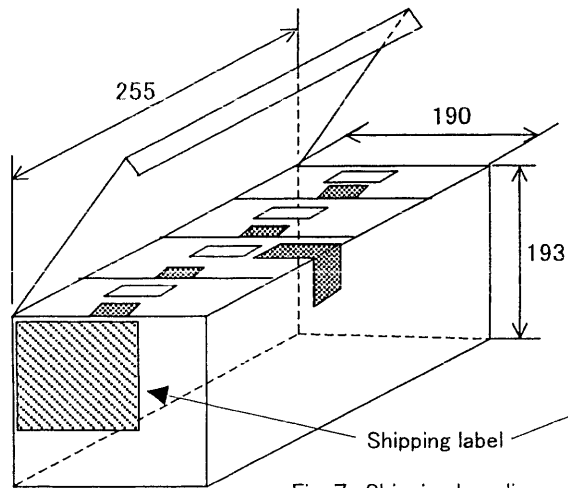

Fig. 6 Packing style

2. 6. Shipping style

4 unit boxes or less per shipping box.



(Unit: mm)

Fig. 7 Shipping box dimensions and shipping style

2. 7. Packing materials

Item	Material
Embossed carrier tape	PS
Cover tape	PET + PE
Reel	PS
Unit box	Cardboard
Shipping box	Cardboard

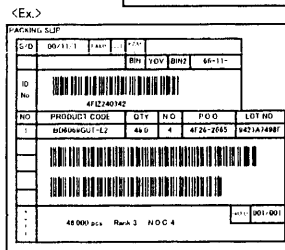

2. 8. Others

2. 8. 1. Peelback strength

Cover tape peelback strength is 0.2~0.7N.

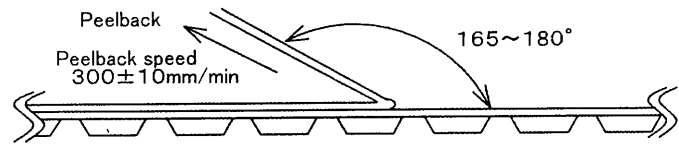

Fig. 8 Test method

2. 8. 2. Dropouts

- (1) No consecutive dropouts.
- (2) A maximum 0.1% of specified number of products in each packing may be missing.

3. Storage conditions

3. 1. Storage environment

Recommended storage conditions are as follows :

- Temperature : 5~30°C
- Humidity : 40~70% RH

3. 2. Storage period

- Specified storage period : 1 year

3. 3. Specified storage period until soldering

This package does not require additional drying treatment as long as the moisture condition at the mounting process is within our recommended mounting condition.

4. Marking lot number

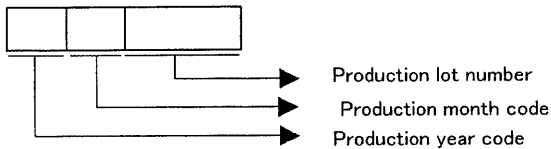

5. Soldering conditions

5. 1. Recommended temperature profile for reflow

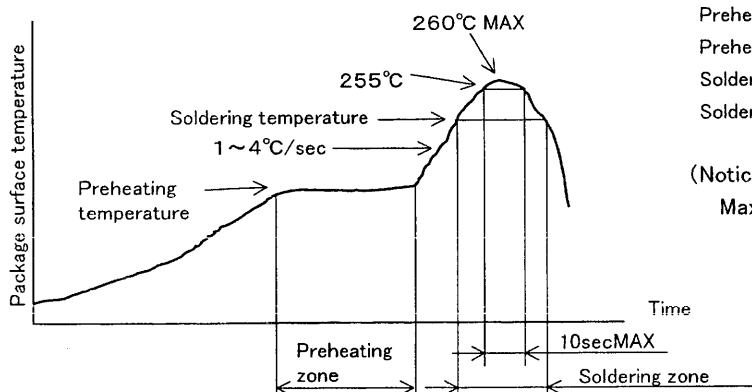

- Preheating temperature ; 130°C~190°C
- Preheating zone ; 120sec MAX
- Soldering temperature ; 220°C~230°C
- Soldering zone ; 60sec MAX

(Notice)
Maximum 2-times soldering

5. 2. About mounting with Sn-Pb solder paste.

Mounting with Sn-Pb solder paste is not recommended because it has a possibility of reducing reliability to connect with Sn-3.0Ag-0.5Cu solder balls.

5. 3. The wave soldering method is not supported.

5. 4. Partial heat supply method (by soldering iron) is not supported.

