



Chipsmall Limited consists of a professional team with an average of over 10 year of expertise in the distribution of electronic components. Based in Hongkong, we have already established firm and mutual-benefit business relationships with customers from,Europe,America and south Asia,supplying obsolete and hard-to-find components to meet their specific needs.

With the principle of “Quality Parts,Customers Priority,Honest Operation,and Considerate Service”,our business mainly focus on the distribution of electronic components. Line cards we deal with include Microchip,ALPS,ROHM,Xilinx,Pulse,ON,Everlight and Freescale. Main products comprise IC,Modules,Potentiometer,IC Socket,Relay,Connector.Our parts cover such applications as commercial,industrial, and automotives areas.

We are looking forward to setting up business relationship with you and hope to provide you with the best service and solution. Let us make a better world for our industry!



Contact us

Tel: +86-755-8981 8866 Fax: +86-755-8427 6832

Email & Skype: info@chipsmall.com Web: www.chipsmall.com

Address: A1208, Overseas Decoration Building, #122 Zhenhua RD., Futian, Shenzhen, China



36V 1ch DC Brush Motor Drivers

BD62110AEFJ

General Description

BD62110AEFJ is a built-in 1 channel H-bridge motor driver for DC brush motors. This driver can facilitate low power consumption by direct PWM. There are built in protection circuits in this IC. Each protection circuit operation contributes to set high reliability.

Features

- Single Power Supply Input (rated voltage of 36V)
- Rated Output Current (peak):1.0A(2.0A)
- Low ON-Resistance DMOS Output
- Forward, Reverse, Brake, Open
- External PWM Control
- Driver for DC Brush Motor
- Built-in logic input pull-down resistor
- Cross-conduction Prevention Circuit
- Thermal Shutdown Circuit (TSD)
- Over-current Protection Circuit (OCP)
- Under Voltage Lock out Circuit (UVLO)
- Over Voltage Lock out Circuit (OVLO)
- Ghost Supply Prevention (protects against malfunction when power supply is disconnected)
- Adjacent Pins Short Protection
- Inverted Mounting Protection
- HTSOP-J8 package

Key Specifications

- Power Supply Voltage Range: 8 to 28 [V]
- Rated Output Current: 1.0 [A]
- Rated Output Current (Peak): 2.0 [A]
- Operating Temperature Range: -25 to +85 [°C]
- Output ON-Resistance: 1.8 [Ω] (Typ)
(Total of upper and lower resistors)

Package

HTSOP-J8

W(Typ) x D(Typ)x H(Max)
4.90mm x 6.00mm x 1.00mm

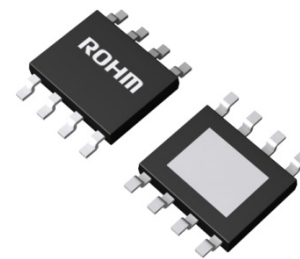

Application

Plain Paper Copier (PPC), Multi-function Printer, Laser Printer, Inkjet Printer, Photo Printer, FAX, Mini Printer and etc.

Typical Application Circuit

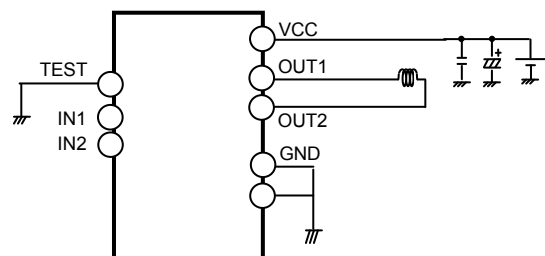

Figure 1. Typical Application Circuit

Pin Configuration

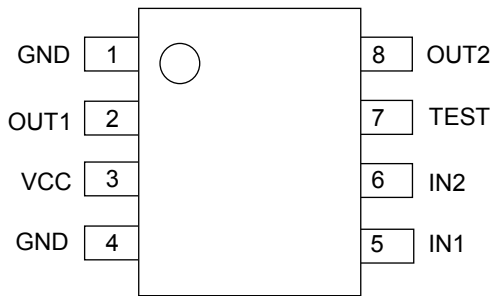

Figure 2. Pin Configuration

Block Diagram

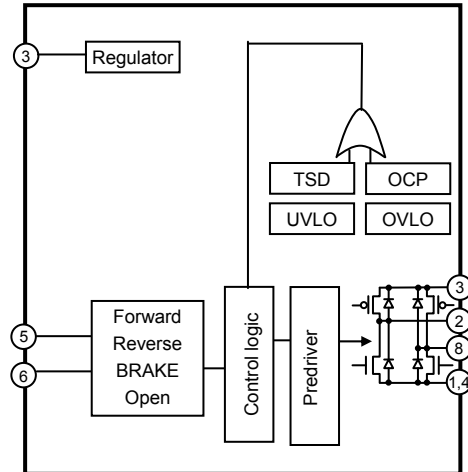

Figure 3. Block Diagram

Pin Descriptions

Pin No.	Pin Name	Function	Pin No.	Pin name	Function
1	GND	Ground terminal	5	IN1	H bridge control terminal
2	OUT1	H bridge output terminal	6	IN2	H bridge control terminal
3	VCC	Power supply terminal	7	TEST	Test terminal (Connected to GND)
4	GND	Ground terminal	8	OUT2	H bridge output terminal

Absolute Maximum Ratings (Ta=25°C)

Parameter	Symbol	Rating	Unit
Supply Voltage	V _{CC}	-0.2 to +36.0	V
Power Dissipation	Pd	0.82 ^(Note 1)	W
		3.75 ^(Note 2)	
Input Voltage for Control Pin	V _{IN}	-0.2 to +5.5	V
Output Current	I _{OUT}	1.0 ^(Note 3)	A/ch
Output Current (peak)	I _{OUTPEAK}	2.0 ^(Note 4)	A/ch
Operating Temperature Range	Topr	-25 to +85	°C
Storage Temperature Range	Tstg	-55 to +150	°C

(Note 1) When mounted on 70mm×70mm×1.6mm glass epoxy board. Reduced by 4.7mW/°C when operating above Ta=25°C.

(Note 2) When mounted using 4-layers, reduced by 30mW/°C when operating above Ta=25°C.

(Note 3) Do not, however exceed Pd and Tjmax=150°C.

(Note 4) Pulse width tw ≤1ms, duty 20ms

Caution: Operating the IC over the absolute maximum ratings may damage the IC. The damage can either be a short circuit between pins or an open circuit between pins and the internal circuitry. Therefore, it is important to consider circuit protection measures, such as adding a fuse, in case the IC is operated over the absolute maximum ratings.

Recommended Operating Conditions (Ta= -25 to +85°C)

Parameter	Symbol	Range	Unit
Supply Voltage	V _{CC}	8 to 28	V
Maximum Output Current (Continuous)	I _{OUT}	0.7 ^(Note 5)	A/ch

(Note 5) Do not, however exceed Pd and Tjmax=150°C.

Electrical Characteristics (Unless otherwise specified Ta=25°C, V_{CC}=24V)

Parameter	Symbol	Limit			Unit	Conditions
		Min	Typ	Max		
【Whole】						
Circuit Current at Standby	I _{CCST}	-	-	10	μA	IN1=L, IN2=L
Circuit Current	I _{CC}	-	1.4	2.5	mA	IN1=H or IN2=H
【Control Input】						
H Level Input Voltage	V _{INH}	2.0	-	-	V	
L Level Input Voltage	V _{INL}	-	-	0.8	V	
H Level Input Current	I _{INH}	35	50	100	μA	V _{IN} =5V
L Level Input Current	I _{INL}	-10	0	-	μA	V _{IN} =0V
【Output (OUT1, OUT2)】						
Output ON-Resistance	R _{ON}	-	1.80	2.30	Ω	I _{OUT} =±0.7A (Sum of upper and lower)
Output Leak Current	I _{LEAK}	-	-	10	μA	

Application Information

1. Points to Notice for Terminal Description and PCB Layout

(1) IN1, IN2/ H Bridge Control Terminal

It decides output logic for H bridge.

Input		Output		State
IN1	IN2	OUT1	OUT2	
L	L	OPEN	OPEN	STOP
H	L	H	L	FORWARD
L	H	L	H	REVERSE
H	H	L	L	BRAKE

(2) TEST/ Terminal for Testing

This is the terminal used at the time of distribution test. Please connect to GND. Please be careful because there is a possibility of malfunction if it is not connected to GND.

(3) VCC/ Power Supply Terminal

Motor's drive current is flowing in it, so please connect it in such a way that the wire is thick & short and has low impedance. VCC voltage may have great fluctuation, so please connect the bypass capacitor (100uF to 470uF) as close as possible to the terminal. Adjust in such a way that the VCC voltage is stable. Please increase the capacitance if needed, especially when large current or motors that have great back electromotive force are used. In addition, to reduce the power supply's impedance in wide frequency bandwidth, parallel connection of multi-layered ceramic capacitor (0.01μF to 0.1μF) is recommended. Extreme care must be observed to make sure that the VCC voltage does not exceed the rating even for a moment. Moreover, there is a built-in clamp component in the output terminal to prevent electrostatic destruction. If sudden pulse or surge voltage of more than the maximum absolute rating is applied, the clamp component operates which can result to destruction. Please be sure to not exceed the maximum absolute rating. It is effective to mount a Zener diode with maximum absolute rating. Also, diode is inserted between VCC terminal and GND terminal to prevent electrostatic destruction. If reverse voltage is applied between VCC terminal and GND terminal, there is a danger of IC destruction so please be careful.

(4) GND/ Ground Terminal

In order to reduce the noise caused by switching current and to stabilize the internal reference voltage of IC, please connect it in such a way that the wiring impedance from this terminal is made as low as possible to achieve the lowest electrical potential no matter what operating state it may be.

(5) OUT1,OUT2/ H Bridge Output Terminal

Motor's drive current is flowing in it, so please connect it in such a way that the wire is thick & short and has low impedance. It is also effective to add a Schottky diode if output has great positive or negative fluctuation when large current is applied. For example, a counter electromotive voltage etc. is great. Moreover, there is a built-in clamp component in the output terminal to prevent electrostatic destruction. If sudden pulse or surge voltage of more than the maximum absolute rating is applied, the clamp component operates which can result to destruction. Please be sure to not exceed the maximum absolute rating.

Protection Circuits

(6) Thermal Shutdown (TSD)

This IC has a built-in Thermal Shutdown circuit for thermal protection. When the IC's chip temperature rises above 175°C (Typ), the motor output becomes OPEN. Also, when the temperature returns to under 150°C (Typ), it automatically returns to normal operation. However, even when TSD is in operation, if heat is continued to be applied externally, heat overdrive can lead to destruction.

(7) Over-Current Protection (OCP)

This IC has a built-in Over-Current Protection circuit as a provision against destruction when the motor outputs are shorted to each other or VCC-motor output or motor output-GND is shorted. This circuit latches the motor output to OPEN condition when the regulated threshold current flows for 4 μ s (typ). It returns with power reactivation. The over-current protection circuit aims to prevent the destruction of the IC only from abnormal situations such as when motor output is shorted and it is not meant to be used as protection or security for the device. Therefore, the device should not be designed to make use of the function of this circuit. After OCP operation, if abnormal situations continues and returned by power reactivation or reset of the PS terminal happens repeatedly, then OCP operates constantly. The IC may generate heat or otherwise deteriorate. When the L value of the wiring is great due to the long wiring and the over-current flows, the output terminal voltage increases and the absolute maximum values may be exceeded. As a result, there is a possibility of destruction. Also, when a current flows, which is over the output current rating and under the OCP detection current, the IC can heat up to over T_{jmax}=150°C. This can deteriorate the IC. Therefore, current which exceeds the output rating should not be applied.

(8) Under Voltage Lock Out (UVLO)

This IC has a built-in Under Voltage Lock Out function to prevent false operation such as IC output during power supply under voltage. When the applied voltage to the VCC terminal goes under 5V (Typ), the motor output is set to OPEN. This switching voltage has a 1V (Typ) hysteresis to prevent false operation by noise etc.

(9) Over Voltage Lock Out (OVLO)

This IC has a built-in Over Voltage Lock Out function to protect the IC output and the motor during power supply over voltage. When the applied voltage to the VCC terminal goes over 32V (Typ), the motor output is set to OPEN. This switching voltage has a 1V (Typ) hysteresis and a 4 μ s (Typ) mask time to prevent false operation by noise etc. Although this over voltage locked out circuit is built-in, there is a possibility of destruction if the absolute maximum value for power supply voltage is exceeded. Therefore, the absolute maximum value should not be exceeded.

(10) Ghost Supply Prevention (protects against malfunction when power supply is disconnected)

If a control signal (IN1, IN2) is applied when there is no power supplied to the IC, there is a function which prevents false operation by voltage applied via the electrostatic destruction prevention diode from the control input terminal to the VCC, to this IC or to another IC's power supply. Therefore, there is no malfunction in the circuit even when voltage is supplied to these input terminals while there is no power supply.

2. External PWM Control

This series can drive motors by IN1 and IN2 input directly from the microcomputer.
Decay mode can be SLOW DECAY or FAST DECAY.

SLOW DECAY (forward rotation)

Input		Output		State
IN1	IN2	OUT1	OUT2	
H	L	H	L	ON
H	H	L	L	SLOW DECAY
H	L	H	L	ON
H	H	L	L	SLOW DECAY
H	L	H	L	ON

FAST DECAY (synchronous rectification, forward rotation)

Input		Output		State
IN1	IN2	OUT1	OUT2	
H	L	H	L	ON
L	H	L	H	FAST DECAY
H	L	H	L	ON
L	H	L	H	FAST DECAY
H	L	H	L	ON

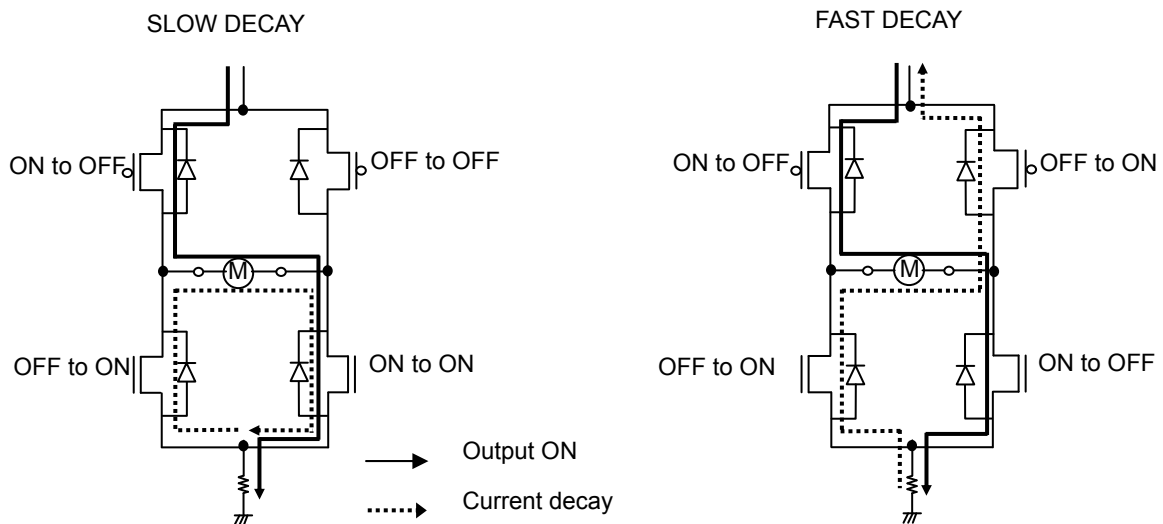

Figure 4. Route of Regenerative Current during Current Decay

Thermal Calculation

The IC's consumed power can be estimated roughly with the power supply voltage (V_{CC}), circuit current (I_{CC}), output ON-Resistance (R_{ONH}, R_{ONL}) and motor output current value (I_{OUT}).

The calculation method during external PWM drive, SLOW DECAY, driving channel 1 only is shown here:

$$\text{Consumed power of the } V_{CC} [W] = V_{CC} [V] \cdot I_{CC} [A] \dots\dots\dots \textcircled{1}$$

$$\text{Consumed power of the output DMOS } [W] = \frac{(R_{ONH}[\Omega] + R_{ONL}[\Omega]) \cdot I_{OUT} [A]^2 \cdot \text{on_duty} [\%] / 100}{\text{During output ON}} + \frac{(2 \cdot R_{ONL}[\Omega]) \cdot I_{OUT} [A]^2 \cdot (100 - \text{on_duty} [\%] / 100)}{\text{During current decay}} \dots\dots \textcircled{2}$$

However, on duty: PWM on duty [%]

Model Number	Upper P-Channel DMOS ON-Resistance R _{ONH} [Ω] (Typ)	Lower N-Channel DMOS ON-Resistance R _{ONL} [Ω] (Typ)
BD62110AEFJ	1.10	0.7

Consumed total power of IC W_{total} [W] = ① + ②
 Junction temperature T_j = T_a [°C] + θ_{ja} [°C/W] · W_{total} [W]

However, the thermal resistance value θ_{ja} [°C/W] differs significantly depending on circuit board conditions. Refer to the Power Dissipation curve. Also, we are taking measurements of thermal resistance value θ_{ja} of the actual boards used. Please feel free to contact our salesman. The calculated values above are only theoretical. For actual thermal design, please perform sufficient thermal evaluation for the application board used, and create the thermal design with enough margin to not exceed T_{jmax}=150°C. Although not normally used, if the IC is to be used under specific or strict heat conditions, please consider attaching an external Schottky diode between the motor output terminal and GND to decrease heat from the IC.

(1) Temperature Monitoring

There is a way to directly measure the approximate chip temperature by using the TEST terminal. However, temperature monitor using TEST terminal is only for evaluation and experimenting, and must not be used in actual usage conditions. TEST terminal has a protection diode to prevent electrostatic discharge. The temperature may be monitored using this protection diode.

- (a) Measure the terminal voltage when a current of I_{DIODE}=50μA flows from the TEST terminal to the GND, without supplying V_{CC} to the IC. This measurement is the V_F voltage inside the diode.
- (b) Measure the temperature characteristics of this terminal voltage. (V_F has a linear negative temperature factor against the temperature.) With the results of these temperature characteristics, chip temperature may be calibrated from the TEST terminal voltage.
- (c) Supply V_{CC}, confirm the TEST terminal voltage while running the motor, and the chip temperature can be approximated from the results of (b).

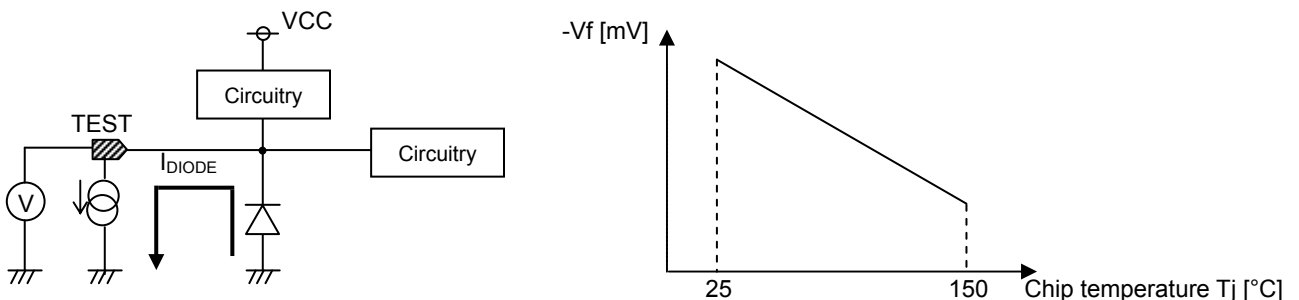

Figure 5. Model Diagram for Measuring Chip Temperature

3. Application Circuit Diagram

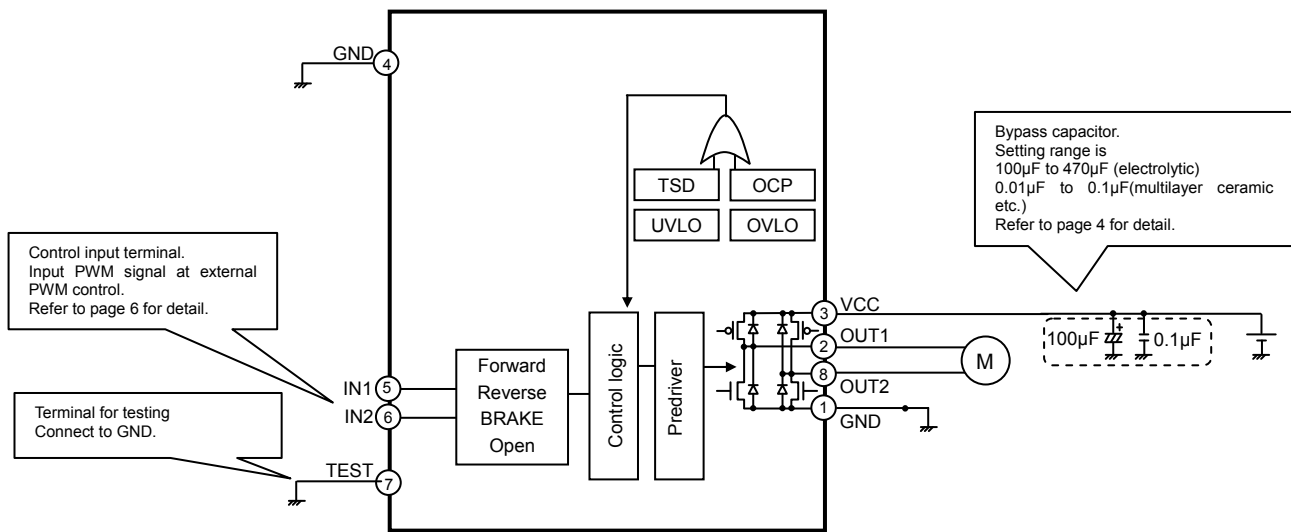

Figure 6. Block Diagram & Application Circuit Diagram
Constant Voltage Control or External PWM Control

(a) Input/Output table

Input		Output		State
IN1	IN2	OUT1	OUT2	
L	L	OPEN	OPEN	STOP
H	L	H	L	FORWARD
L	H	L	H	REVERSE
H	H	L	L	BRAKE

(b) Example of external PWM control sequence
SLOW DECAY (forward rotation)

Input		Output		State
IN1	IN2	OUT1	OUT2	
H	L	H	L	ON
H	H	L	L	SLOW DECAY
H	L	H	L	ON
H	H	L	L	SLOW DECAY
H	L	H	L	ON

FAST DECAY (forward rotation)

Input		Output		State
IN1	IN2	OUT1	OUT2	
H	L	H	L	ON
L	H	L	H	FAST DECAY
H	L	H	L	ON
L	H	L	H	FAST DECAY
H	L	H	L	ON

I/O Equivalent Circuits

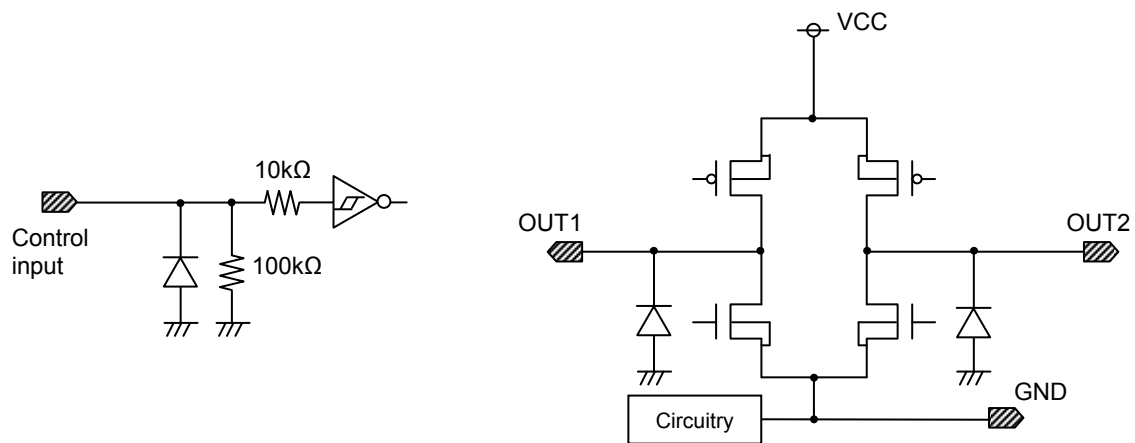

Figure 7. I/O Equivalent Circuits

Operational Notes

1. Reverse Connection of Power Supply

Connecting the power supply in reverse polarity can damage the IC. Take precautions against reverse polarity when connecting the power supply, such as mounting an external diode between the power supply and the IC's power supply pins.

2. Power Supply Lines

Design the PCB layout pattern to provide low impedance supply lines. Furthermore, connect a capacitor to ground at all power supply pins. Consider the effect of temperature and aging on the capacitance value when using electrolytic capacitors.

3. Ground Voltage

Ensure that no pins are at a voltage below that of the ground pin at any time, even during transient condition.

4. Ground Wiring Pattern

When using both small-signal and large-current ground traces, the two ground traces should be routed separately but connected to a single ground at the reference point of the application board to avoid fluctuations in the small-signal ground caused by large currents. Also ensure that the ground traces of external components do not cause variations on the ground voltage. The ground lines must be as short and thick as possible to reduce line impedance.

5. Thermal Consideration

Should by any chance the maximum junction temperature rating be exceeded the rise in temperature of the chip may result in deterioration of the properties of the chip. In case of exceeding this absolute maximum rating, increase the board size and copper area to prevent exceeding the maximum junction temperature rating.

6. Recommended Operating Conditions

These conditions represent a range within which the expected characteristics of the IC can be approximately obtained. The electrical characteristics are guaranteed under the conditions of each parameter.

7. Inrush Current

When power is first supplied to the IC, it is possible that the internal logic may be unstable and inrush current may flow instantaneously due to the internal powering sequence and delays, especially if the IC has more than one power supply. Therefore, give special consideration to power coupling capacitance, power wiring, width of ground wiring, and routing of connections.

8. Operation Under Strong Electromagnetic Field

Operating the IC in the presence of a strong electromagnetic field may cause the IC to malfunction.

9. Testing on Application Boards

When testing the IC on an application board, connecting a capacitor directly to a low-impedance output pin may subject the IC to stress. Always discharge capacitors completely after each process or step. The IC's power supply should always be turned off completely before connecting or removing it from the test setup during the inspection process. To prevent damage from static discharge, ground the IC during assembly and use similar precautions during transport and storage.

Operational Notes – continued

10. **Inter-pin Short and Mounting Errors**

Ensure that the direction and position are correct when mounting the IC on the PCB. Incorrect mounting may result in damaging the IC. Avoid nearby pins being shorted to each other especially to ground, power supply and output pin. Inter-pin shorts could be due to many reasons such as metal particles, water droplets (in very humid environment) and unintentional solder bridge deposited in between pins during assembly to name a few.

11. **Unused Input Pins**

Input pins of an IC are often connected to the gate of a MOS transistor. The gate has extremely high impedance and extremely low capacitance. If left unconnected, the electric field from the outside can easily charge it. The small charge acquired in this way is enough to produce a significant effect on the conduction through the transistor and cause unexpected operation of the IC. So unless otherwise specified, unused input pins should be connected to the power supply or ground line.

12. **Regarding the Input Pin of the IC**

This monolithic IC contains P+ isolation and P substrate layers between adjacent elements in order to keep them isolated. P-N junctions are formed at the intersection of the P layers with the N layers of other elements, creating a parasitic diode or transistor. For example (refer to figure below):

When $GND > Pin A$ and $GND > Pin B$, the P-N junction operates as a parasitic diode.
When $GND > Pin B$, the P-N junction operates as a parasitic transistor.

Parasitic diodes inevitably occur in the structure of the IC. The operation of parasitic diodes can result in mutual interference among circuits, operational faults, or physical damage. Therefore, conditions that cause these diodes to operate, such as applying a voltage lower than the GND voltage to an input pin (and thus to the P substrate) should be avoided.

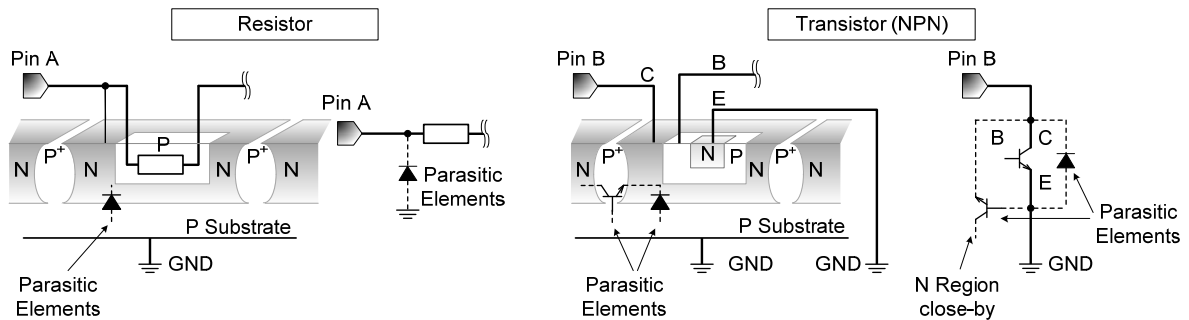

Figure 8. Example of monolithic IC structure

13. **Thermal Shutdown Circuit(TSD)**

This IC has a built-in thermal shutdown circuit that prevents heat damage to the IC. Normal operation should always be within the IC's maximum junction temperature rating. If however the rating is exceeded for a continued period, the junction temperature (T_j) will rise which will activate the TSD circuit that will turn OFF all output pins. When the T_j falls below the TSD threshold, the circuits are automatically restored to normal operation.

Note that the TSD circuit operates in a situation that exceeds the absolute maximum ratings and therefore, under no circumstances, should the TSD circuit be used in a set design or for any purpose other than protecting the IC from heat damage.

14. **Over Current Protection Circuit (OCP)**

This IC incorporates an integrated overcurrent protection circuit that is activated when the load is shorted. This protection circuit is effective in preventing damage due to sudden and unexpected incidents. However, the IC should not be used in applications characterized by continuous operation or transitioning of the protection circuit.

Power Dissipation

HTSOP-J8 Package

HTSOP-J8 has exposed metal on the back, and it is possible to dissipate heat from a through hole in the back. Also, the back of board as well as the surfaces has large areas of copper foil heat dissipation patterns, greatly increasing power dissipation. The back metal is shorted with the back side of the IC chip, being a GND potential, therefore there is a possibility for malfunction if it is shorted with any potential other than GND, which should be avoided. Also, it is recommended that the back metal is soldered onto the GND to short. Please note that it has been assumed that this product will be used in the condition of this back metal performed heat dissipation treatment for increasing heat dissipation efficiency.

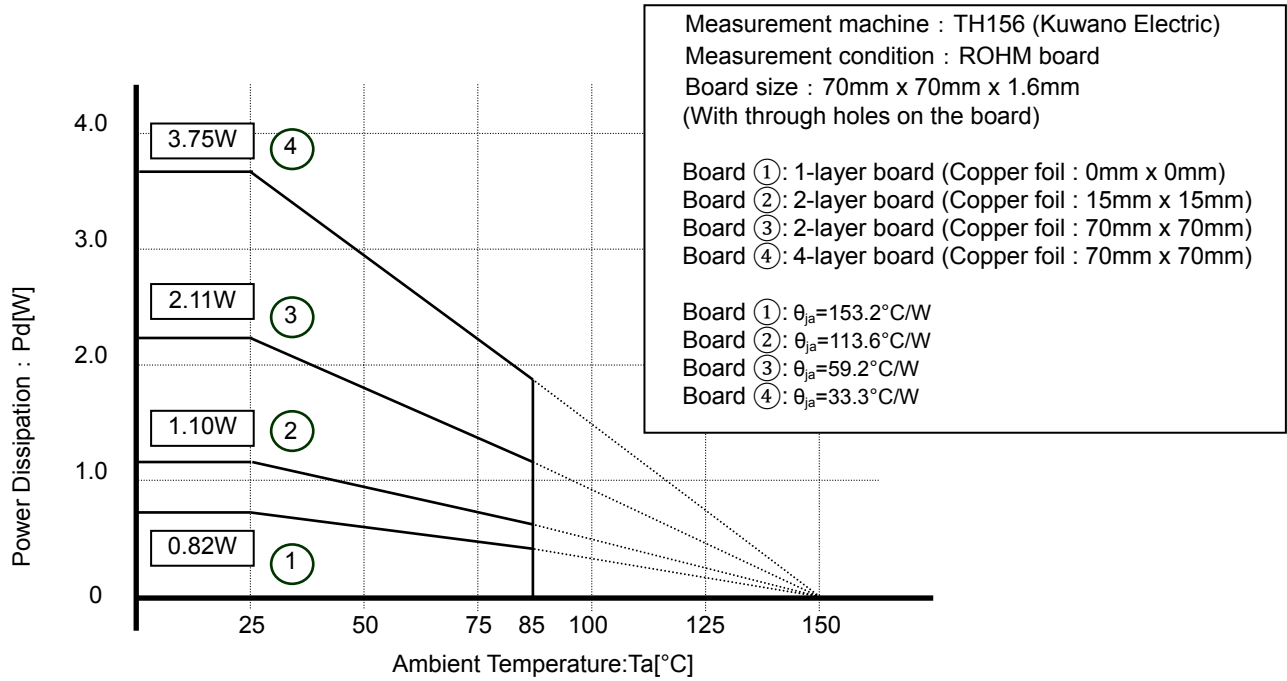
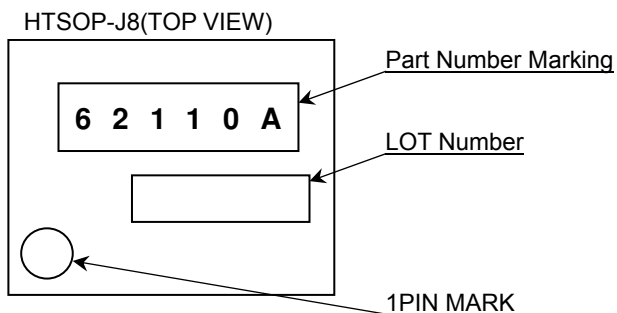

Figure 9. HTSOP-J8 Power Dissipation

Ordering Information



Marking Diagram



Physical Dimension, Tape and Reel Information

Package Name	HTSOP-J8
--------------	----------

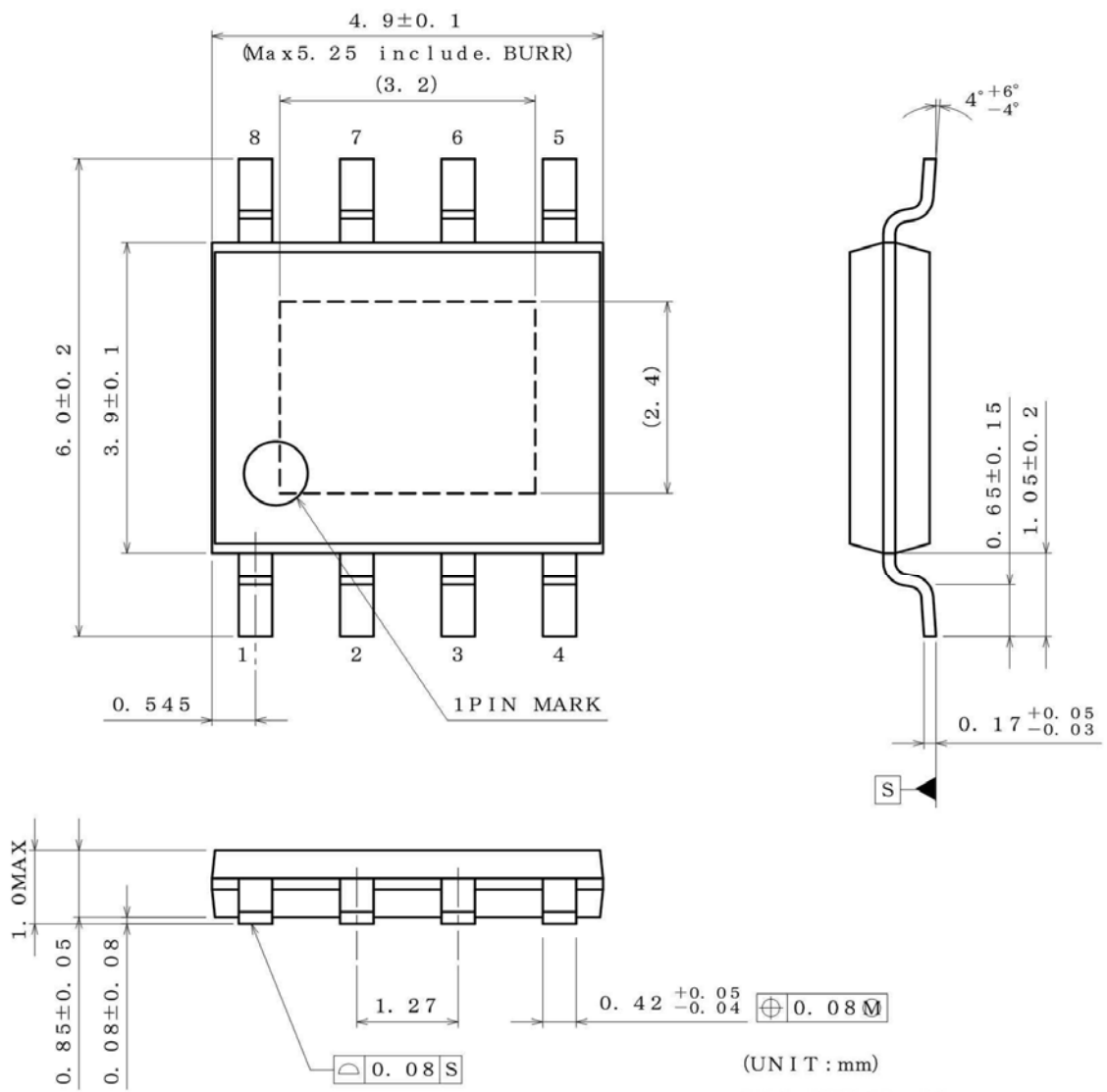

(UNIT : mm)
 PKG : HTSOP-J8
 Drawing No. EX169-5002-2

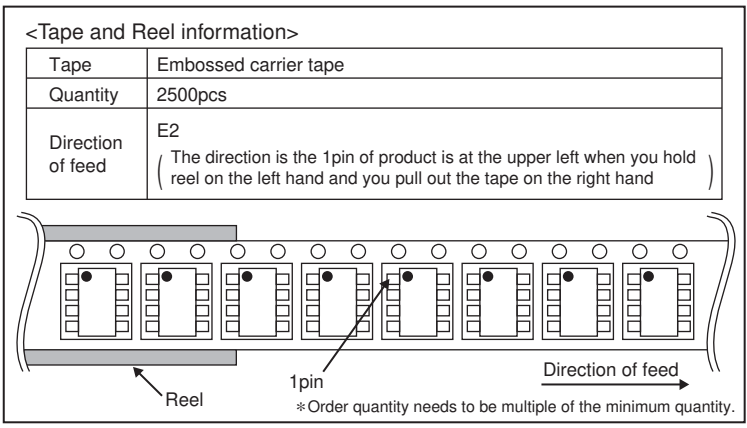

Revision History

Date	Revision	Changes
25.May.2016	001	New Release

Notice

Precaution on using ROHM Products

- Our Products are designed and manufactured for application in ordinary electronic equipments (such as AV equipment, OA equipment, telecommunication equipment, home electronic appliances, amusement equipment, etc.). If you intend to use our Products in devices requiring extremely high reliability (such as medical equipment ^(Note 1), transport equipment, traffic equipment, aircraft/spacecraft, nuclear power controllers, fuel controllers, car equipment including car accessories, safety devices, etc.) and whose malfunction or failure may cause loss of human life, bodily injury or serious damage to property ("Specific Applications"), please consult with the ROHM sales representative in advance. Unless otherwise agreed in writing by ROHM in advance, ROHM shall not be in any way responsible or liable for any damages, expenses or losses incurred by you or third parties arising from the use of any ROHM's Products for Specific Applications.

(Note1) Medical Equipment Classification of the Specific Applications

JAPAN	USA	EU	CHINA
CLASS III	CLASS III	CLASS II b	CLASS III
CLASS IV		CLASS III	

- ROHM designs and manufactures its Products subject to strict quality control system. However, semiconductor products can fail or malfunction at a certain rate. Please be sure to implement, at your own responsibilities, adequate safety measures including but not limited to fail-safe design against the physical injury, damage to any property, which a failure or malfunction of our Products may cause. The following are examples of safety measures:
 - Installation of protection circuits or other protective devices to improve system safety
 - Installation of redundant circuits to reduce the impact of single or multiple circuit failure
- Our Products are designed and manufactured for use under standard conditions and not under any special or extraordinary environments or conditions, as exemplified below. Accordingly, ROHM shall not be in any way responsible or liable for any damages, expenses or losses arising from the use of any ROHM's Products under any special or extraordinary environments or conditions. If you intend to use our Products under any special or extraordinary environments or conditions (as exemplified below), your independent verification and confirmation of product performance, reliability, etc. prior to use, must be necessary:
 - Use of our Products in any types of liquid, including water, oils, chemicals, and organic solvents
 - Use of our Products outdoors or in places where the Products are exposed to direct sunlight or dust
 - Use of our Products in places where the Products are exposed to sea wind or corrosive gases, including Cl₂, H₂S, NH₃, SO₂, and NO₂
 - Use of our Products in places where the Products are exposed to static electricity or electromagnetic waves
 - Use of our Products in proximity to heat-producing components, plastic cords, or other flammable items
 - Sealing or coating our Products with resin or other coating materials
 - Use of our Products without cleaning residue of flux (even if you use no-clean type fluxes, cleaning residue of flux is recommended); or Washing our Products by using water or water-soluble cleaning agents for cleaning residue after soldering
 - Use of the Products in places subject to dew condensation
- The Products are not subject to radiation-proof design.
- Please verify and confirm characteristics of the final or mounted products in using the Products.
- In particular, if a transient load (a large amount of load applied in a short period of time, such as pulse. is applied, confirmation of performance characteristics after on-board mounting is strongly recommended. Avoid applying power exceeding normal rated power; exceeding the power rating under steady-state loading condition may negatively affect product performance and reliability.
- De-rate Power Dissipation depending on ambient temperature. When used in sealed area, confirm that it is the use in the range that does not exceed the maximum junction temperature.
- Confirm that operation temperature is within the specified range described in the product specification.
- ROHM shall not be in any way responsible or liable for failure induced under deviant condition from what is defined in this document.

Precaution for Mounting / Circuit board design

- When a highly active halogenous (chlorine, bromine, etc.) flux is used, the residue of flux may negatively affect product performance and reliability.
- In principle, the reflow soldering method must be used on a surface-mount products, the flow soldering method must be used on a through hole mount products. If the flow soldering method is preferred on a surface-mount products, please consult with the ROHM representative in advance.

For details, please refer to ROHM Mounting specification

Precautions Regarding Application Examples and External Circuits

1. If change is made to the constant of an external circuit, please allow a sufficient margin considering variations of the characteristics of the Products and external components, including transient characteristics, as well as static characteristics.
2. You agree that application notes, reference designs, and associated data and information contained in this document are presented only as guidance for Products use. Therefore, in case you use such information, you are solely responsible for it and you must exercise your own independent verification and judgment in the use of such information contained in this document. ROHM shall not be in any way responsible or liable for any damages, expenses or losses incurred by you or third parties arising from the use of such information.

Precaution for Electrostatic

This Product is electrostatic sensitive product, which may be damaged due to electrostatic discharge. Please take proper caution in your manufacturing process and storage so that voltage exceeding the Products maximum rating will not be applied to Products. Please take special care under dry condition (e.g. Grounding of human body / equipment / solder iron, isolation from charged objects, setting of ionizer, friction prevention and temperature / humidity control).

Precaution for Storage / Transportation

1. Product performance and soldered connections may deteriorate if the Products are stored in the places where:
 - [a] the Products are exposed to sea winds or corrosive gases, including Cl₂, H₂S, NH₃, SO₂, and NO₂
 - [b] the temperature or humidity exceeds those recommended by ROHM
 - [c] the Products are exposed to direct sunshine or condensation
 - [d] the Products are exposed to high Electrostatic
2. Even under ROHM recommended storage condition, solderability of products out of recommended storage time period may be degraded. It is strongly recommended to confirm solderability before using Products of which storage time is exceeding the recommended storage time period.
3. Store / transport cartons in the correct direction, which is indicated on a carton with a symbol. Otherwise bent leads may occur due to excessive stress applied when dropping of a carton.
4. Use Products within the specified time after opening a humidity barrier bag. Baking is required before using Products of which storage time is exceeding the recommended storage time period.

Precaution for Product Label

A two-dimensional barcode printed on ROHM Products label is for ROHM's internal use only.

Precaution for Disposition

When disposing Products please dispose them properly using an authorized industry waste company.

Precaution for Foreign Exchange and Foreign Trade act

Since concerned goods might be fallen under listed items of export control prescribed by Foreign exchange and Foreign trade act, please consult with ROHM in case of export.

Precaution Regarding Intellectual Property Rights

1. All information and data including but not limited to application example contained in this document is for reference only. ROHM does not warrant that foregoing information or data will not infringe any intellectual property rights or any other rights of any third party regarding such information or data.
2. ROHM shall not have any obligations where the claims, actions or demands arising from the combination of the Products with other articles such as components, circuits, systems or external equipment (including software).
3. No license, expressly or implied, is granted hereby under any intellectual property rights or other rights of ROHM or any third parties with respect to the Products or the information contained in this document. Provided, however, that ROHM will not assert its intellectual property rights or other rights against you or your customers to the extent necessary to manufacture or sell products containing the Products, subject to the terms and conditions herein.

Other Precaution

1. This document may not be reprinted or reproduced, in whole or in part, without prior written consent of ROHM.
2. The Products may not be disassembled, converted, modified, reproduced or otherwise changed without prior written consent of ROHM.
3. In no event shall you use in any way whatsoever the Products and the related technical information contained in the Products or this document for any military purposes, including but not limited to, the development of mass-destruction weapons.
4. The proper names of companies or products described in this document are trademarks or registered trademarks of ROHM, its affiliated companies or third parties.

General Precaution

1. Before you use our Products, you are requested to carefully read this document and fully understand its contents. ROHM shall not be in any way responsible or liable for failure, malfunction or accident arising from the use of any ROHM's Products against warning, caution or note contained in this document.
2. All information contained in this document is current as of the issuing date and subject to change without any prior notice. Before purchasing or using ROHM's Products, please confirm the latest information with a ROHM sales representative.
3. The information contained in this document is provided on an "as is" basis and ROHM does not warrant that all information contained in this document is accurate and/or error-free. ROHM shall not be in any way responsible or liable for any damages, expenses or losses incurred by you or third parties resulting from inaccuracy or errors of or concerning such information.