



Chipsmall Limited consists of a professional team with an average of over 10 year of expertise in the distribution of electronic components. Based in Hongkong, we have already established firm and mutual-benefit business relationships with customers from,Europe,America and south Asia,supplying obsolete and hard-to-find components to meet their specific needs.

With the principle of "Quality Parts,Customers Priority,Honest Operation,and Considerate Service",our business mainly focus on the distribution of electronic components. Line cards we deal with include Microchip,ALPS,ROHM,Xilinx,Pulse,ON,Everlight and Freescale. Main products comprise IC,Modules,Potentiometer,IC Socket,Relay,Connector.Our parts cover such applications as commercial,industrial, and automotives areas.

We are looking forward to setting up business relationship with you and hope to provide you with the best service and solution. Let us make a better world for our industry!



## Contact us

Tel: +86-755-8981 8866 Fax: +86-755-8427 6832

Email & Skype: info@chipsmall.com Web: www.chipsmall.com

Address: A1208, Overseas Decoration Building, #122 Zhenhua RD., Futian, Shenzhen, China



## Stepping Motor Driver series

# High Performance, High Reliability 36V Series Stepping Motor Drivers

**BD6387xEFV Series**

No.12009EAT10

**●Description**

BD6387xEFV series are the high-grade type that provides the highest function and highest reliance in the ROHM stepping motor driver series.

As for its basic function, it is a low power consumption bipolar PWM constant current-drive driver with power BD63877/BD63875/BD63873EFV are CLK-IN type drivers and BD63876/BD63874/BD63872EFV are PARALLEL-IN type drivers. There are excitation modes of FULL STEP & HALF STEP (2 kinds), QUARTER STEP mode, and for current decay mode, the ratio of FAST DECAY & SLOW DECAY can be freely set, so the optimum control conditions for every motor can be realized. In addition, being able to drive with one system of power supply makes contribution to the set design's getting easy.

**●Feature**

- 1) Single power supply input (rated voltage of 36V)
- 2) Rated output current:(DC) 1.0A, 1.5A, 2.0A
- 3) Low ON resistance DMOS output
- 4) CLK-IN drive mode (BD63877/63875/63873EFV)
- 5) PARALLEL-IN drive mode (BD63876/63874/63872EFV)
- 6) PWM constant current control (other oscillation)
- 7) Built-in spike noise cancel function (external noise filter is unnecessary)
- 8) Full-, half (two kinds)-, quarter-step functionality
- 9) Current decay mode switching function (linearly variable FAST/SLOW DECAY ratio)
- 10) Normal rotation & reverse rotation switching function (BD63877/63875/63873EFV)
- 11) Power save function
- 12) Built-in logic input pull-down resistor
- 13) Power-on reset function (BD63877/63875/63873EFV)
- 14) Thermal shutdown circuit (TSD)
- 15) Over current protection circuit (OCP)
- 16) Under voltage lock out circuit (UVLO)
- 17) Over voltage lock out circuit (OVLO)
- 18) Ghost Supply Prevention (protects against malfunction when power supply is disconnected)
- 19) Electrostatic discharge: 8kV (HBM specification)
- 20) Adjacent pins short protection
- 21) Inverted mounting protection
- 22) Microminiature, ultra-thin and high heat-radiation (exposed metal type) HTSSOP-B28 package
- 23) Pin-compatible line-up (BD63877/63875/63873EFV, BD63876/63874/63872EFV)

**●Application**

PPC, multi-function printer, laser beam printer, ink jet printer, monitoring camera, WEB camera, sewing machine, photo printer, FAX, scanner, mini printer, toy, and robot etc.

## ● Absolute maximum ratings (Ta=25°C)

Item	Symbol	BD63877/63876EFV	BD63875/63874EFV	BD63873/63872EFV	Unit
Supply voltage	V <sub>CC1,2</sub>	-0.2~+36.0			V
Power dissipation	Pd	1.45 <sup>※1</sup>			W
		4.70 <sup>※2</sup>			W
Input voltage for control pin	V <sub>IN</sub>	-0.2~+5.5			V
RNF maximum voltage	V <sub>RNF</sub>	0.7			V
Maximum output current	I <sub>OUT</sub>	2.0 <sup>※3</sup>	1.5 <sup>※3</sup>	1.0 <sup>※3</sup>	A/phase
Maximum output current (PEAK) <sup>※4</sup>	I <sub>OUTPEAK</sub>	2.5 <sup>※3</sup>	2.0 <sup>※3</sup>	1.5 <sup>※3</sup>	A/phase
Operating temperature range	T <sub>opr</sub>	-25~+85			°C
Storage temperature range	T <sub>stg</sub>	-55~+150			°C
Junction temperature	T <sub>jmax</sub>	+150			°C

※1 70mm × 70mm × 1.6mm glass epoxy board. Derating in done at 11.6mW/°C for operating above Ta=25°C.

※2 4-layer recommended board. Derating in done at 37.6mW/°C for operating above Ta=25°C.

※3 Do not, however exceed Pd, ASO and Tjmax=150°C.

※4 Pulse width tw ≤ 1ms, duty 20%.

## ● Operating conditions (Ta= -25~+85°C)

Item	Symbol	BD63877/63876EFV	BD63875/63874EFV	BD63873/63872EFV	Unit
Supply voltage	V <sub>CC1,2</sub>	19~28			V
Maximum Output current (DC)	I <sub>OUT</sub>	1.7 <sup>※5</sup>	1.2 <sup>※5</sup>	0.7 <sup>※5</sup>	A/phase

※5 Do not, however exceed Pd, ASO and .

● Electrical characteristics (Unless otherwise specified Ta=25°C, V<sub>CC1,2</sub>=24V)

Item	Symbol	Limit			Unit	Conditions
		Min.	Typ.	Max.		
<b>Whole</b>						
Circuit current at standby	I <sub>CCST</sub>	-	1.0	2.5	mA	PS=L
Circuit current	I <sub>CC</sub>	-	2.5	5.0	mA	PS=H, VREF=3V
<b>Control input</b>						
H level input voltage	V <sub>INH</sub>	2.0	-	-	V	
L level input voltage	V <sub>INL</sub>	-	-	0.8	V	
H level input current	I <sub>INH</sub>	35	50	100	μA	V <sub>IN</sub> =5V
L level input current	I <sub>INL</sub>	-10	0	-	μA	V <sub>IN</sub> =0V
<b>Output (OUT1A, OUT1B, OUT2A, OUT2B)</b>						
Output ON resistance (BD63877/63876EFV)	R <sub>ON</sub>	-	0.65	0.85	Ω	I <sub>OUT</sub> =1.5A, Sum of upper and lower
Output ON resistance (BD63875/63874EFV)	R <sub>ON</sub>	-	1.00	1.30	Ω	I <sub>OUT</sub> =1.0A, Sum of upper and lower
Output ON resistance (BD63873/63872EFV)	R <sub>ON</sub>	-	1.90	2.47	Ω	I <sub>OUT</sub> =0.5A, Sum of upper and lower
Output leak current	I <sub>LEAK</sub>	-	-	10	μA	
<b>Current control</b>						
RNFXS input current	I <sub>RNFS</sub>	-2.0	-0.1	-	μA	RNFXS=0V
RNFX input current	I <sub>RNF</sub>	-40	-20	-	μA	RNFX=0V
VREF input current	I <sub>VREF</sub>	-2.0	-0.1	-	μA	VREF=0V
VREF input voltage range	V <sub>REF</sub>	0	-	3.0	V	
MTH input current	I <sub>MTH</sub>	-2.0	-0.1	-	μA	MTH=0V
MTH input voltage range	V <sub>MTH</sub>	0	-	3.5	V	
Minimum on time (Blank time)	t <sub>ONMIN</sub>	0.3	0.8	1.5	μs	C=1000pF, R=39kΩ
<b>BD63877EFV/63875EFV/63873EFV</b>						
Comparator threshold	V <sub>CTH</sub>	0.57	0.60	0.63	V	VREF=3V
<b>BD63876EFV/63874EFV/63872EFV</b>						
Comparator threshold 100%	V <sub>CTH100</sub>	0.57	0.60	0.63	V	VREF=3V, (I0X,I1X)=(L,L)
Comparator threshold 67%	V <sub>CTH67</sub>	0.38	0.40	0.42	V	VREF=3V, (I0X,I1X)=(H,L)
Comparator threshold 33%	V <sub>CTH33</sub>	0.18	0.20	0.22	V	VREF=3V, (I0X,I1X)=(L,H)



● Terminal function and Application circuit diagram

CLK-IN type (BD63877/63875/63873EFV)

Pin No.	Pin name	Function	Pin No.	Pin name	Function
1	GND	Ground terminal	15	CLK	Clock input terminal for advancing the electrical angle.
2	OUT1B	H bridge output terminal	16	CW_CCW	Motor rotating direction setting terminal
3	RNF1	Connection terminal of resistor for output current detection	17	TEST	Terminal for testing (used by connecting with GND)
4	RNF1S	Input terminal of current limit comparator	18	MODE0	Motor excitation mode setting terminal
5	OUT1A	H bridge output terminal	19	MODE1	Motor excitation mode setting terminal
6	NC	Non connection	20	ENABLE	Power supply terminal
7	VCC1	Power supply terminal	21	NC	Non connection
8	NC	Non connection	22	VCC2	Power supply terminal
9	GND	Ground terminal	23	NC	Non connection
10	CR	Connection terminal of CR for setting chopping frequency	24	OUT2A	H bridge output terminal
11	NC	Non connection	25	RNF2S	Input terminal of current limit comparator
12	MTH	Current decay mode setting terminal	26	RNF2	Connection terminal of resistor for output current detection
13	VREF	Output current value setting terminal	27	OUT2B	H bridge output terminal
14	PS	Power save terminal	28	NC	Non connection

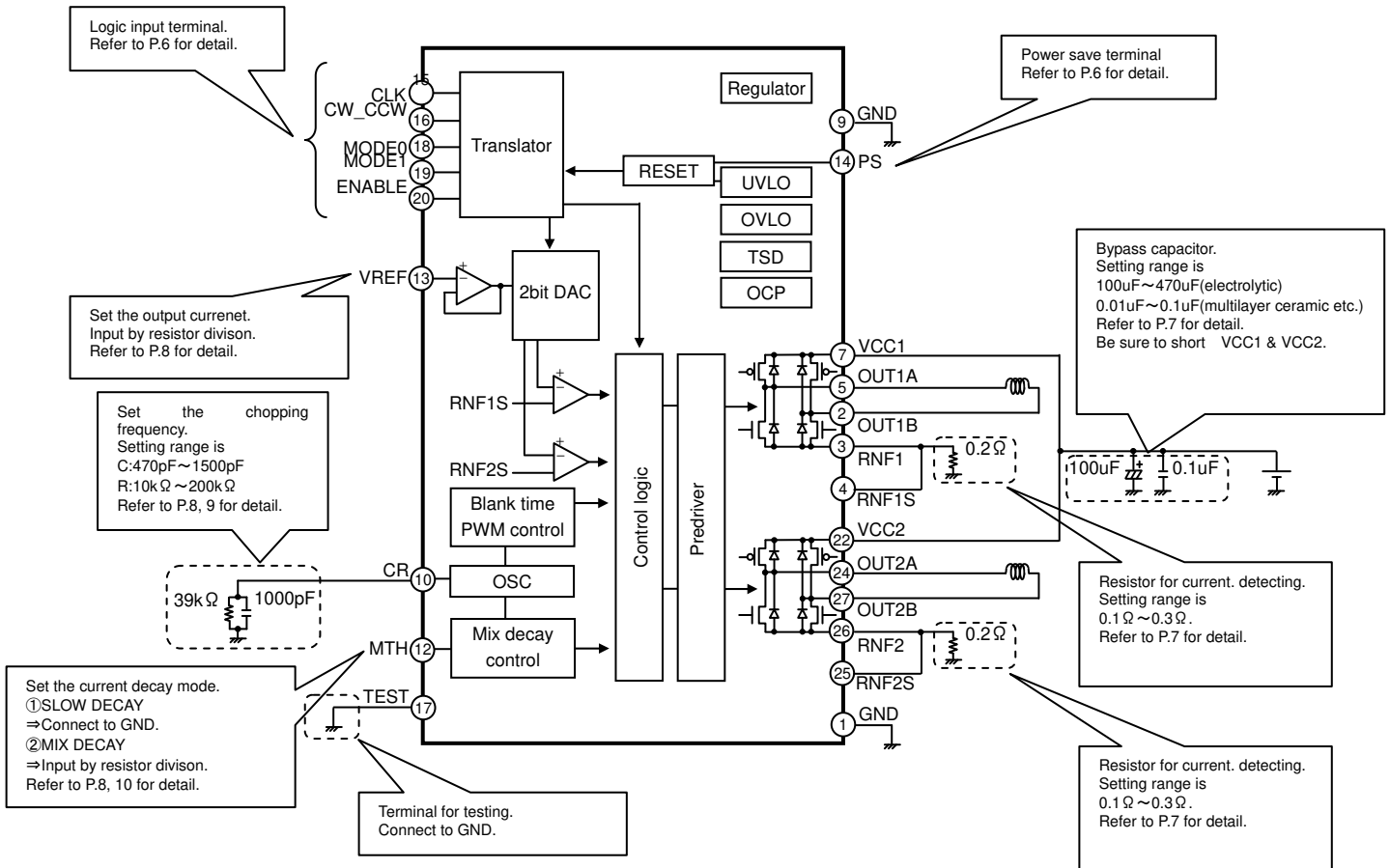

Fig.1 Block diagram & Application circuit diagram of BD63877EFV/BD63875EFV/BD63873EFV

PARALLEL-IN type (BD63876/63874/63872EFV)

Pin No.	Pin name	Function	Pin No.	Pin name	Function
1	GND	Ground terminal	15	PHASE1	Phase selection terminal
2	OUT1B	H bridge output terminal	16	I01	VREF division ratio setting terminal
3	RNF1	Connection terminal of resistor for output current detection	17	I11	VREF division ratio setting terminal
4	RNF1S	Input terminal of current limit comparator	18	PHASE2	Phase selection pin
5	OUT1A	H bridge output terminal	19	I02	VREF division ratio setting terminal
6	NC	Non connection	20	I12	VREF division ratio setting terminal
7	VCC1	Power supply terminal	21	NC	Non connection
8	NC	Non connection	22	VCC2	Power supply terminal
9	GND	Ground terminal	23	NC	Non connection
10	CR	Connection terminal of CR for setting chopping frequency	24	OUT2A	H bridge output terminal
11	NC	Non connection	25	RNF2S	Input terminal of current limit comparator
12	MTH	Current decay mode setting terminal	26	RNF2	Connection terminal of resistor for output current detection
13	VREF	Output current value setting terminal	27	OUT2B	H bridge output terminal
14	PS	Power save terminal	28	NC	Non connection

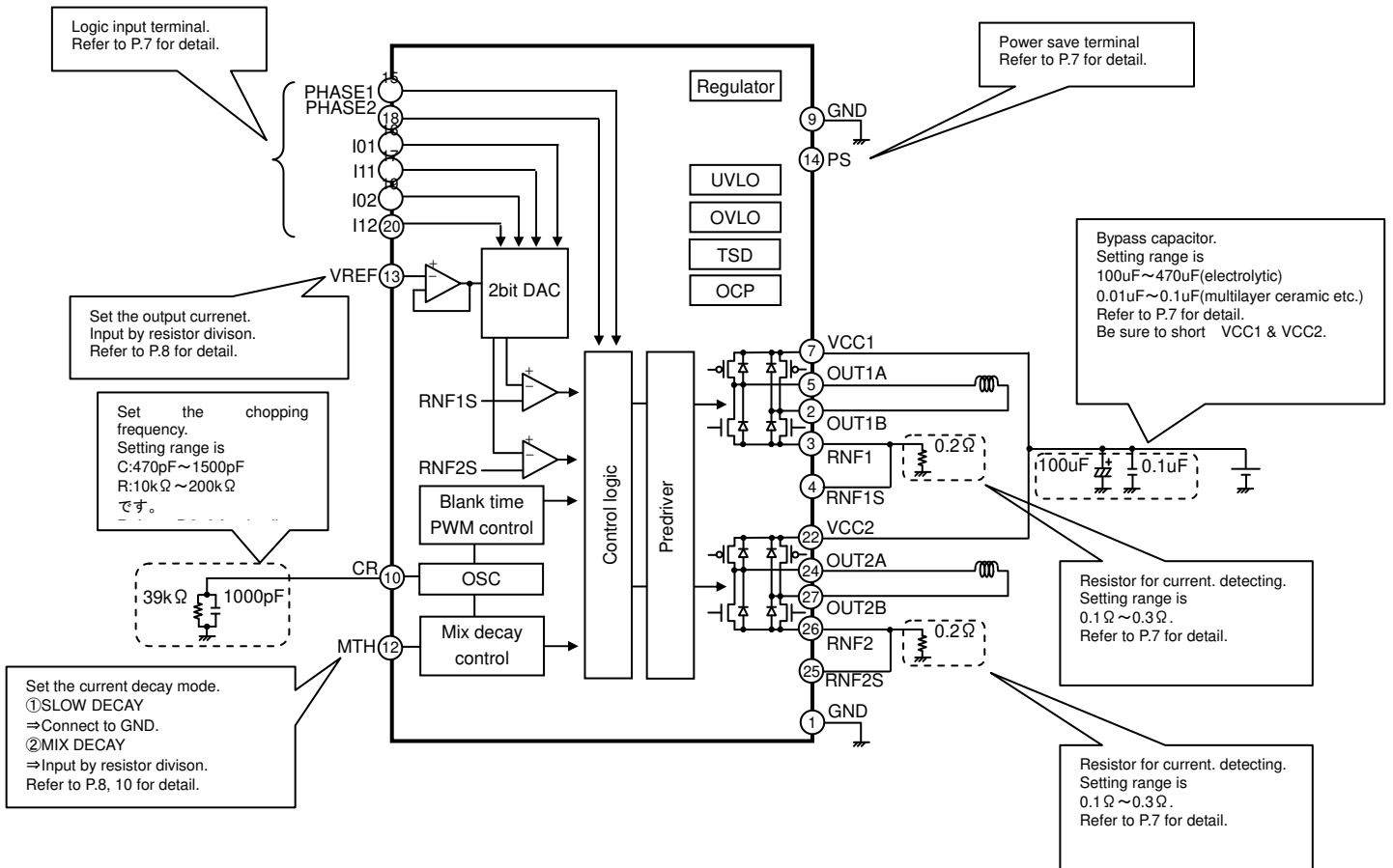

Fig.2Block diagram & Application circuit diagram of BD63876FV/BD63874FV/BD63872FV

### ●Points to notice for terminal description

#### ○CLK/Clock input terminal for advancing the electrical angle(BD63877/BD63875/BD63873EFV)

CLK is reflected at rising edge. The Electrical angle advances by one for each CLK input.

Motor's misstep will occur if noise is picked up at the CLK terminal, so please design the pattern in such a way that there is no noise plunging.

#### ○MODE0,MODE1/Motor excitation mode setting terminal (BD63877/BD63875/BD63873EFV)

Set the motor excitation mode.

MODE0	MODE1	Excitation mode
L	L	FULL STEP
H	L	HALF STEP A
L	H	HALF STEP B
H	H	QUARTER STEP

#### ○CW CCW Terminal/Motor rotating direction setting terminal (BD63877/BD63875/BD63873EFV)

Set the motor's rotating direction. Change in setting is reflected at the CLK rising edge immediately after the change in setting

CW CCW	Rotating direction
L	Clockwise (CH2's current is outputted with a phase lag of 90° in regard to CH1's current)
H	Counter Clockwise(CH2's current is outputted with a phase lead of 90° in regard to CH1's current)

#### ○ENABLE Terminal/Output enable terminal (BD63877/BD63875/BD63873EFV)

Turn off forcibly all the output transistors (motor output is open).

At the time of ENABLE=L, electrical angle or operating mode is maintained even if CLK is inputted.

Please be careful because the electrical angle at the time of ENABLE being released (ENABLE=L→H) is different from the released occasion at the section of CLK=H and from the released occasion at the section of CLK=L

ENABLE	Motor output
L	OPEN (electrical angle maintained)
H	ACTIVE

#### ○OPS/Power save terminal (BD63877/BD63875/BD63873EFV)

PS can make circuit standby state and make motor output OPEN. In standby state, translator circuit is reset (initialized) and electrical angle is initialized.

Please be careful because there is a delay of 40μs(max.) before it is returned from standby state to normal state and the motor output becomes ACTIVE

PS	State
L	Standby state (RESET)
H	ACTIVE

The electrical angle (initial electrical angle) of each excitation mode immediately after RESET is as follows Please be careful because the initial state at the time of FULL STEP is different from those of other excitation modes.

Excitation mode	Initial electrical angle
FULL STEP	45°
HALFSTEP A	0°
HALFSTEP B	0°
QUARTER STEP	0°

### ●Protection Circuits

#### ○Thermal Shutdown (TSD)

This IC has a built-in thermal shutdown circuit for thermal protection. When the IC's chip temperature rises above 175°C (Typ.), the motor output becomes OPEN. Also, when the temperature returns to under 150°C (Typ.), it automatically returns to normal operation. However, even when TSD is in operation, if heat is continued to be added externally, heat overdrive can lead to destruction.

#### ○Over Current Protection (OCP)

This IC has a built in over current protection circuit as a provision against destruction when the motor outputs are shorted each other or VCC-motor output or motor output-GND is shorted. This circuit latches the motor output to OPEN condition when the regulated threshold current flows for 4 $\mu$ s (Typ.). It returns with power reactivation or a reset of the PS terminal. The over current protection circuit's only aim is to prevent the destruction of the IC from irregular situations such as motor output shorts, and is not meant to be used as protection or security for the set. Therefore, sets should not be designed to take into account this circuit's functions. After OCP operating, if irregular situations continues and the return by power reactivation or a reset of the PS terminal is carried out repeatedly, then OCP operates repeatedly and the IC may generate heat or otherwise deteriorate. When the L value of the wiring is great due to the wiring being long, after the over current has flowed and the output terminal voltage jumps up and the absolute maximum values may be exceeded and as a result, there is a possibility of destruction. Also, when current which is over the output current rating and under the OCP detection current flows, the IC can heat up to over T<sub>jmax</sub>=150°C and can deteriorate, so current which exceeds the output rating should not be applied.

#### ○Under Voltage Lock Out (UVLO)

This IC has a built-in under voltage lock out function to prevent false operation such as IC output during power supply under voltage. When the applied voltage to the VCC terminal goes under 15V (Typ.), the motor output is set to OPEN. This switching voltage has a 1V (Typ.) hysteresis to prevent false operation by noise etc. Please be aware that this circuit does not operate during power save mode. Also, the electrical angle is reset when the UVLO circuit operates during CLK-IN drive mode.

#### ○Over Voltage Lock Out (OVLO)

This IC has a built-in over voltage lock out function to protect the IC output and the motor during power supply over voltage. When the applied voltage to the VCC terminal goes over 32V (Typ.), the motor output is set to OPEN. This switching voltage has a 1V (Typ.) hysteresis and a 4 $\mu$ s (Typ.) mask time to prevent false operation by noise etc. Although this over voltage locked out circuit is built-in, there is a possibility of destruction if the absolute maximum value for power supply voltage is exceeded, therefore the absolute maximum value should not be exceeded. Please be aware that this circuit does not operate during power save mode.

#### ○Ghost Supply Prevention (protects against malfunction when power supply is disconnected)

If a signal (logic input, VREF, MTH) is input when there is no power supplied to this IC, there is a function which prevents the false operation by voltage supplied via the electrostatic destruction prevention diode from these input terminals to the VCC to this IC or to another IC's power supply. Therefore, there is no malfunction of the circuit even when voltage is supplied to these input terminals while there is no power supply.

### ●Usage Notes

#### (1) Absolute maximum ratings

An excess in the absolute maximum ratings, such as supply voltage, temperature range of operating conditions, etc., can break down the devices, thus making impossible to identify breaking mode, such as a short circuit or an open circuit. If any over rated values will expect to exceed the absolute maximum ratings, consider adding circuit protection devices, such as fuses.

#### (2) Connecting the power supply connector backward

Connecting of the power supply in reverse polarity can damage IC. Take precautions when connecting the power supply lines. An external direction diode can be added.

#### (3) Power supply Lines

Design PCB layout pattern to provide low impedance GND and supply lines. To obtain a low noise ground and supply line, separate the ground section and supply lines of the digital and analog blocks. Furthermore, for all power supply terminals to ICs, connect a capacitor between the power supply and the GND terminal. When applying electrolytic capacitors in the circuit, not that capacitance characteristic values are reduced at low temperatures.

#### (4) GND Potential

The potential of GND pin must be minimum potential in all operating conditions.

#### (5) Metal on the backside (Define the side where product markings are printed as front)

The metal on the backside is shorted with the backside of IC chip therefore it should be connected to GND. Be aware that there is a possibility of malfunction or destruction if it is shorted with any potential other than GND.

#### (6) Thermal design

Use a thermal design that allows for a sufficient margin in light of the power dissipation (Pd) in actual operating conditions. Users should be aware that these products have been designed to expose their frames at the back of the package, and should be used with suitable heat dissipation treatment in this area to improve dissipation. As large a dissipation pattern should be taken as possible, not only on the front of the baseboard but also on the back surface. It is important to consider actual usage conditions and to take as large a dissipation pattern as possible.

(7) Inter-pin shorts and mounting errors

When attaching to a printed circuit board, pay close attention to the direction of the IC and displacement. Improper attachment may lead to destruction of the IC. There is also possibility of destruction from short circuits which can be caused by foreign matter entering between outputs or an output and the power supply or GND.

(8) Operation in a strong electric field

Use caution when using the IC in the presence of a strong electromagnetic field as doing so may cause the IC to malfunction.

(9) ASO

When using the IC, set the output transistor so that it does not exceed absolute maximum ratings or ASO.

(10) Thermal shutdown circuit

The IC has a built-in thermal shutdown circuit (TSD circuit). If the chip temperature becomes  $T_{jmax}=150^{\circ}\text{C}$ , and higher, coil output to the motor will be open. The TSD circuit is designed only to shut the IC off to prevent runaway thermal operation. It is not designed to protect or indemnify peripheral equipment. Do not use the TSD function to protect peripheral equipment.

TSD on temperature [ $^{\circ}\text{C}$ ] (Typ.)	Hysteresis Temperature [ $^{\circ}\text{C}$ ] (Typ.)
175	25

(11) Inspection of the application board

During inspection of the application board, if a capacitor is connected to a pin with low impedance there is a possibility that it could cause stress to the IC, therefore an electrical discharge should be performed after each process. Also, as a measure against electrostatic discharge, it should be earthed during the assembly process and special care should be taken during transport or storage. Furthermore, when connecting to the jig during the inspection process, the power supply should first be turned off and then removed before the inspection.

(12) Input terminal of IC

This IC is a monolithic IC, and between each element there is a P+ isolation for element partition and a P substrate.

This P layer and each element's N layer make up the P-N junction, and various parasitic elements are made up.

For example, when the resistance and transistor are connected to the terminal as shown in figure 3,

○When  $\text{GND} > (\text{Terminal A})$  at the resistance and  $\text{GND} > (\text{Terminal B})$  at the transistor (NPN), the P-N junction operates as a parasitic diode.

○Also, when  $\text{GND} > (\text{Terminal B})$  at the transistor (NPN)

The parasitic NPN transistor operates with the N layers of other elements close to the aforementioned parasitic diode.

Because of the IC's structure, the creation of parasitic elements is inevitable from the electrical potential relationship. The operation of parasitic elements causes interference in circuit operation, and can lead to malfunction and destruction. Therefore, be careful not to use it in a way which causes the parasitic elements to operate, such as by applying voltage that is lower than the GND (P substrate) to the input terminal.

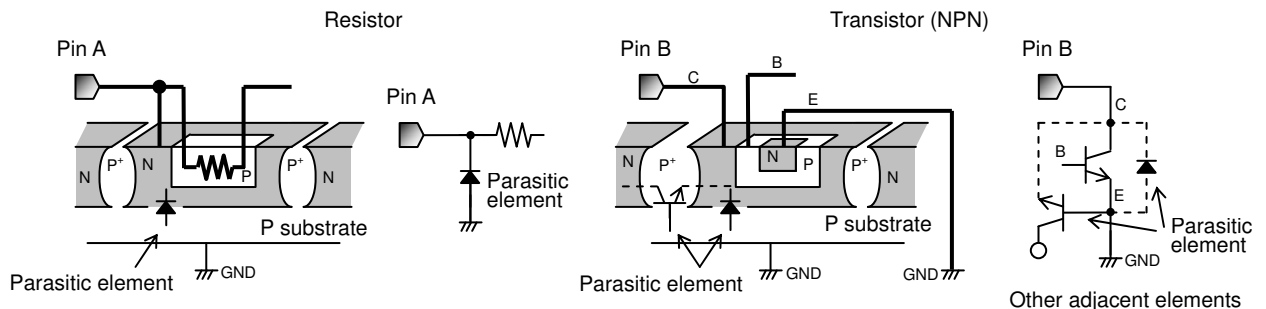

Fig. 3 Pattern Diagram of Parasitic Element

(13) Ground Wiring Patterns

When using both small signal and large current GND patterns, it is recommended to isolate the two ground patterns, placing a single ground point at the application's reference point so that the pattern wiring resistance and voltage variations caused by large currents do not cause variations in the small signal ground voltage. Be careful not to change the GND wiring pattern potential of any external components, either.

(14) TEST Terminal (BD63877/BD63875/BD63873EFV)

Be sure to connect TEST pin to GND.



●Ordering part number

B D 6 3 8 7 2 E F V - E 2

形名	パッケージ EFV=HTSSOP-B28	包装、フォーミング仕様 E2: リール状エンボステーピング
----	-------------------------	----------------------------------

HTSSOP-B28

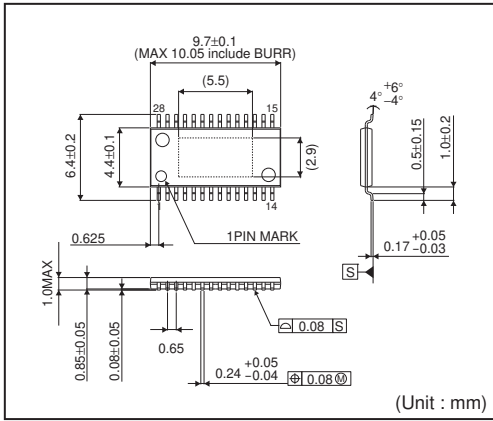

<Tape and Reel information>

Tape	Embossed carrier tape (with dry pack)
Quantity	2500pcs
Direction of feed	E2 ( The direction is the 1 pin of product is at the upper left when you hold reel on the left hand and you pull out the tape on the right hand )

Reel

1pin

Direction of feed

\* Order quantity needs to be multiple of the minimum quantity.

## Notes

No copying or reproduction of this document, in part or in whole, is permitted without the consent of ROHM Co.,Ltd.

The content specified herein is subject to change for improvement without notice.

The content specified herein is for the purpose of introducing ROHM's products (hereinafter "Products"). If you wish to use any such Product, please be sure to refer to the specifications, which can be obtained from ROHM upon request.

Examples of application circuits, circuit constants and any other information contained herein illustrate the standard usage and operations of the Products. The peripheral conditions must be taken into account when designing circuits for mass production.

Great care was taken in ensuring the accuracy of the information specified in this document. However, should you incur any damage arising from any inaccuracy or misprint of such information, ROHM shall bear no responsibility for such damage.

The technical information specified herein is intended only to show the typical functions of and examples of application circuits for the Products. ROHM does not grant you, explicitly or implicitly, any license to use or exercise intellectual property or other rights held by ROHM and other parties. ROHM shall bear no responsibility whatsoever for any dispute arising from the use of such technical information.

The Products specified in this document are intended to be used with general-use electronic equipment or devices (such as audio visual equipment, office-automation equipment, communication devices, electronic appliances and amusement devices).

The Products specified in this document are not designed to be radiation tolerant.

While ROHM always makes efforts to enhance the quality and reliability of its Products, a Product may fail or malfunction for a variety of reasons.

Please be sure to implement in your equipment using the Products safety measures to guard against the possibility of physical injury, fire or any other damage caused in the event of the failure of any Product, such as derating, redundancy, fire control and fail-safe designs. ROHM shall bear no responsibility whatsoever for your use of any Product outside of the prescribed scope or not in accordance with the instruction manual.

The Products are not designed or manufactured to be used with any equipment, device or system which requires an extremely high level of reliability the failure or malfunction of which may result in a direct threat to human life or create a risk of human injury (such as a medical instrument, transportation equipment, aerospace machinery, nuclear-reactor controller, fuel-controller or other safety device). ROHM shall bear no responsibility in any way for use of any of the Products for the above special purposes. If a Product is intended to be used for any such special purpose, please contact a ROHM sales representative before purchasing.

If you intend to export or ship overseas any Product or technology specified herein that may be controlled under the Foreign Exchange and the Foreign Trade Law, you will be required to obtain a license or permit under the Law.



Thank you for your accessing to ROHM product informations.  
More detail product informations and catalogs are available, please contact us.

### ROHM Customer Support System

<http://www.rohm.com/contact/>