



Chipsmall Limited consists of a professional team with an average of over 10 year of expertise in the distribution of electronic components. Based in Hongkong, we have already established firm and mutual-benefit business relationships with customers from,Europe,America and south Asia,supplying obsolete and hard-to-find components to meet their specific needs.

With the principle of “Quality Parts,Customers Priority,Honest Operation,and Considerate Service”,our business mainly focus on the distribution of electronic components. Line cards we deal with include Microchip,ALPS,ROHM,Xilinx,Pulse,ON,Everlight and Freescale. Main products comprise IC,Modules,Potentiometer,IC Socket,Relay,Connector.Our parts cover such applications as commercial,industrial, and automotives areas.

We are looking forward to setting up business relationship with you and hope to provide you with the best service and solution. Let us make a better world for our industry!



Contact us

Tel: +86-755-8981 8866 Fax: +86-755-8427 6832

Email & Skype: info@chipsmall.com Web: www.chipsmall.com

Address: A1208, Overseas Decoration Building, #122 Zhenhua RD., Futian, Shenzhen, China



System Lens Driver Series for Digital Still Cameras/Single-lens Reflex Cameras



1 to 2ch Lens Drivers for Single-Lens Reflex Cameras

BD6735FV, BD6736FV

No.09014EAT03

●Description

The BD6735FV motor driver provides 2 Full-ON Drive H-bridge channels, while BD6736FV provides 1 Full-ON Drive H-bridge channel. ROHM's lens driver series features high voltage resistance and large current output in a compact surface mount package, making it ideally suited for smaller systems such as Single-Lens Reflex with Interchangeable Lenses.

●Features

- 1) Low ON-Resistance Power MOS output: Full-ON Drive block with 1.0Ω Typ. (BD6735FV)
Full-ON Drive block with 0.35Ω Typ. (BD6736FV)
- 2) DMOS output allowing a range power supply: 2.0V to 8.0V (BD6735FV), 2.0V to 9.0V (BD6736FV)
- 3) Built-in step-up circuit for the DMOS gate voltage drive
- 4) Drive mode switching function
- 5) H bridge maximum output current: DC maximum 1.0A (BD6735FV and BD6736FV), Peak maximum 3.2A (BD6736FV)
- 6) UVLO (Under Voltage Lockout Protection) function
- 7) Built-in TSD (Thermal Shut Down) circuit
- 8) Standby current consumption: 0μA Typ.

●Absolute Maximum Ratings

Parameter	Symbol	Limit		Unit
		BD6735FV	BD6736FV	
Power supply voltage	VCC	-0.5 to +10.0	-0.5 to +10.0	V
Motor power supply voltage	VM	-0.5 to +10.0	-0.5 to +10.0	V
Charge pump step-up power supply voltage	VBST	-0.5 to +15.0	-0.5 to +15.0	V
Control input voltage	VIN	-0.5 to VCC+0.5	-0.5 to VCC+0.5	V
Power dissipation	Pd	810 ^{*1}	810 ^{*1}	mW
Operating temperature range	Topr	-30 to +75	-30 to +75	°C
Junction temperature	Tjmax	+150	+150	°C
Storage temperature range	Tstg	-55 to +150	-55 to +150	°C
H-bridge output current (DC)	Iout	-1000 to +1000 ^{*2}	-1000 to +1000 ^{*2}	mA/ch
H-bridge output current (Peak)	Ipeak	-	-3200 to +3200 ^{*3}	mA/ch

※1 Reduced by 6.48mW/°C over 25°C, when mounted on a glass epoxy board (70mm × 70mm × 1.6mm).

※2 Must not exceed Pd, ASO, or Tjmax of 150°C

※3 Peak=100msec

●Operating Conditions (Ta=-30 to +75°C)

Parameter	Symbol	Limit		Unit
		BD6735FV	BD6736FV	
Power supply voltage	VCC	2.0 to 8.0	2.0 to 9.0	V
Motor power supply voltage	VM	2.0 to 8.0	2.0 to 9.0	V
Control input voltage	VIN	0 to VCC	0 to VCC	V
Logic input frequency	FIN	0 to 100	0 to 100	kHz
Min. logic input pulse width	TIN	0.5	0.5	μs

●Electrical Characteristics

1) BD6735FV and BD6736FV Electrical Characteristics (Unless otherwise specified, Ta=25°C, VCC=5.0V, VM=5.0V)

Parameter	Symbol	Limit			Unit	Conditions
		Min.	Typ.	Max.		
Overall						
Circuit current during standby operation	ICCST	-	0	1	μA	PS=0V
Circuit current (BD6735FV)	ICC	0.5	2.0	4.0	mA	PS=H, FIN=100kHz
Circuit current (BD6736FV)	ICC	0.5	1.5	4.0	mA	PS=H, FIN=100kHz
Power saving (PS)						
High-level input voltage	VPSH	2.0	-	VCC	V	
Low-level input voltage	VPSL	-0.3	-	0.5	V	
High-level input current	IPSH	25	50	100	μA	VPSH=5V
Low-level input current	IPSL	-1	0	1	μA	VPSL=0V
Control input (BD6735FV; INxA, INxB, PWMEN, and BD6736FV; INA, INB, PWM)						
High-level input voltage	VINH	2.0	-	VCC	V	
Low-level input voltage	VINL	-0.3	-	0.7	V	
High-level input current	IINH	25	50	100	μA	VINH=5V
Low-level input current	IINL	-1	0	1	μA	VINL=0V
UVLO						
UVLO voltage	VUVLO	1.5	-	1.9	V	
BD6735FV Full-ON Drive block (ch1 and ch2)						
Output ON-Resistance	RON	-	1.0	1.35	Ω	Io=±700mA on high and low sides in total
BD6736FV Full-ON Drive block (ch1)						
Output ON-Resistance	RON	-	0.35	0.5	Ω	Io=±500mA on high and low sides in total

●Electrical Characteristics

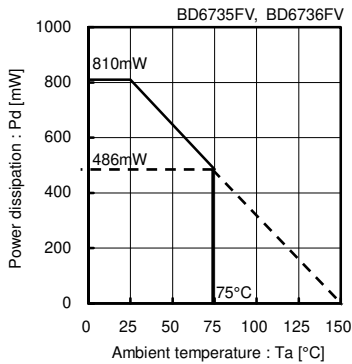

Fig.1 Power Dissipation Reduction

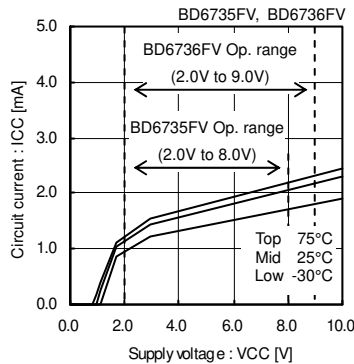

Fig.2 Circuit current

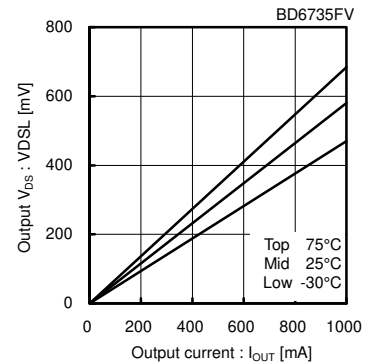

Fig.3 Output ON-Voltage on High-Side

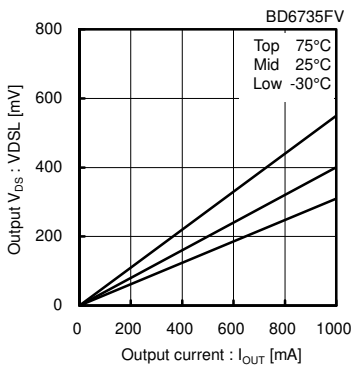

Fig.4 Output ON-Voltage on Low-Side

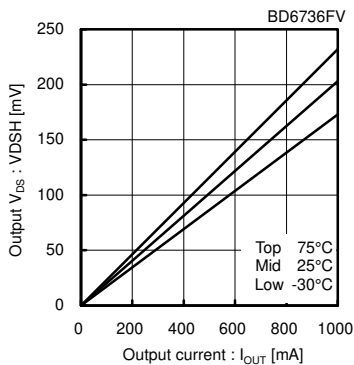

Fig.5 Output ON-Voltage on High-Side

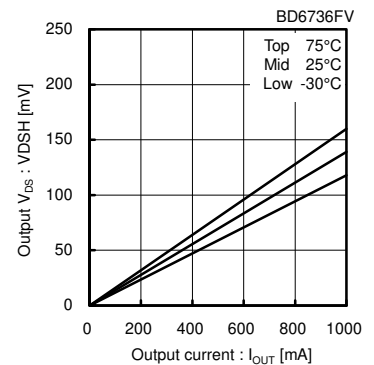

Fig.6 Output ON-Voltage on Low-Side

●Application Circuit Diagram, Pin Function, and Pin Arrangement

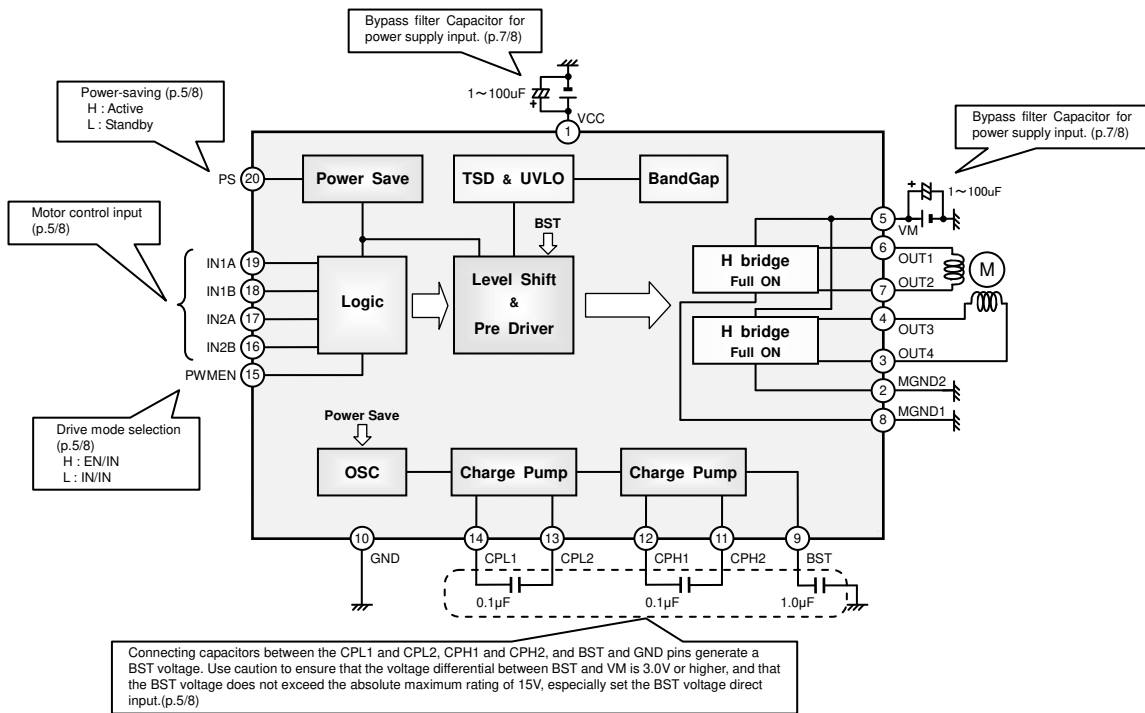

Fig.7 BD6735FV Application Circuit Diagram

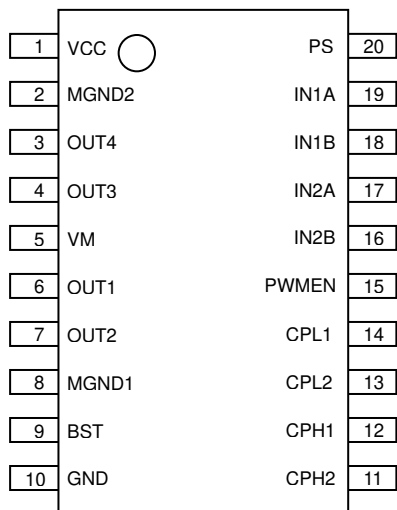

Fig.8 BD6735FV Pin Arrangement (Top View)

BD6735FV Pin Function Table

No.	Pin Name	Function
1	VCC	Power supply pin
2	MGND2	Motor ground pin 2
3	OUT4	H-bridge output pin 4
4	OUT3	H-bridge output pin 3
5	VM	Motor power supply pin
6	OUT1	H-bridge output pin 1
7	OUT2	H-bridge output pin 2
8	MGND1	Motor ground pin 1
9	BST	Charge pump step-up power supply pin
10	GND	Ground pin
11	CPH2	Capacitor connection pin for second charge 2
12	CPH1	Capacitor connection pin for second charge 1
13	CPL2	Capacitor connection pin for first charge 2
14	CPL1	Capacitor connection pin for first charge 1
15	PWMEN	Drive mode selection pin
16	IN2B	Control input pin ch2 B
17	IN2A	Control input pin ch2 A
18	IN1B	Control input pin ch1 B
19	IN1A	Control input pin ch1 A
20	PS	Power-saving pin

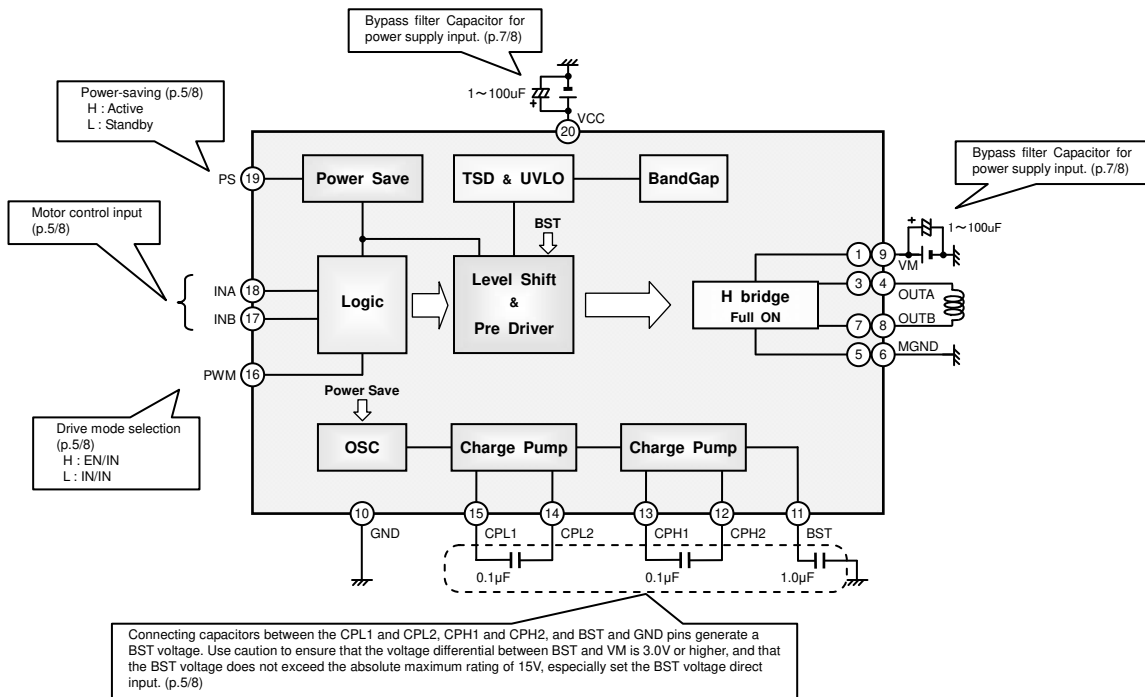

Fig.9 BD6736FV Application Circuit Diagram

BD6736FV Pin Function Table

No.	Pin Name	Function
1	VM	Motor power supply pin
2	N.C.	-
3	OUTA	H-bridge output pin A
4	OUTA	H-bridge output pin A
5	MGND	Motor ground pin
6	MGND	Motor ground pin
7	OUTB	H-bridge output pin B
8	OUTB	H-bridge output pin B
9	VM	Motor power supply pin
10	GND	Ground pin
11	BST	Charge pump step-up power supply pin
12	CPH2	Capacitor connection pin for second charge 2
13	CPH1	Capacitor connection pin for second charge 1
14	CPL2	Capacitor connection pin for first charge 2
15	CPL1	Capacitor connection pin for first charge 1
16	PWM	Drive mode selection pin
17	INB	Control input pin ch1 B
18	INA	Control input pin ch1 A
19	PS	Power-saving pin
20	VCC	Power supply pin

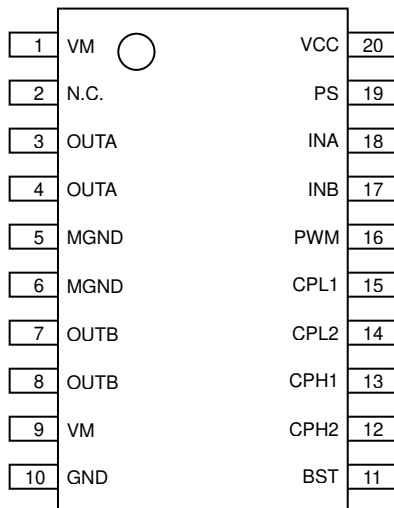

Fig.10 BD6736FV Pin Arrangement (Top View)

●Function Explanation

- 1) Power-saving function
When Low-level voltage is applied to PS pin, the IC will be turned off internally and the circuit current will be 0 μ A (Typ.). During operating mode, PS pin should be High-level. (See the Electrical Characteristics; p.2/8)
- 2) Motor Control input
 - (1) INxA and INxB pins (BD6735FV), INA and INB pins (BD6736FV)
These pins are used to program and control the motor drive modes. (See the Electrical Characteristics; p.2/8, and I/O Truth Table; p.5/8)
 - (2) PWMEN pin (BD6735FV), PWM pin (BD6736FV)
When the High-level voltage is applied to the PWMEN pin (PWM pin), the I/O logic can be set to EN/IN mode. However, when the Low-level voltage is applied, the I/O logic can be set to IN/IN mode. (See the Electrical Characteristics; p.2/8, and I/O Truth Table; p.5/8)
- 3) H-bridge
The 2-channel H-bridges can be controlled independently. For this reason, it is possible to drive the H-bridges simultaneously, as long as the package thermal tolerances are not exceeded.
The H-bridge output transistors consist of Power DMOS with the charge pump step-up power supply BST.
The total H-bridge ON-Resistance on the high and low sides varies with the BST voltages.
- 4) Charge pump
Each output H-bridge on the high and low sides consists of Nch DMOS. Therefore, the gate voltage BST should be higher than the VM voltage to drive the Nch DMOS on the high side.
The BD6735FV and BD6736FV have a built-in charge pump circuit that generates BST voltage by connecting an external capacitor, between CPL1 and CPL2, CPH1 and CPH2, BST and GND.
In order to ensure better performance, the voltage differential between BST and VM must be 3.0V or higher, and the BST voltage must not exceed the absolute maximum rating of 15.0V.

●I/O Truth Table

BD6735FV I/O Truth Table

Drive mode	INPUT				OUTPUT		Output mode	
	PS	PWM EN	IN1A/2A	IN1B/2B	OUT1/3	OUT2/4		
EN/IN	H	H	L	X	L	L	Brake	
			H	L	H	L	CW	
			H	H	L	H	CCW	
IN/IN		L	L	L	L	Z	Z	Standby
				H	L	H	L	CW
				L	H	L	H	CCW
-	L	X	H	H	L	L	Brake	
			X	X	Z	Z	Standby	

L: Low, H: High, X: Don't care, Z: High Impedance

At CW, current flows from OUT1(3) to OUT2(4). At CCW, current flows from OUT2(4) to OUT1(3).

BD6736FV I/O Truth Table

Drive mode	INPUT				OUTPUT		Output mode	
	PS	PWM	INA	INB	OUTA	OUTB		
EN/IN	H	H	L	X	L	L	Brake	
			H	L	H	L	CW	
			H	H	L	H	CCW	
IN/IN		L	L	L	L	Z	Z	Standby
				H	L	H	L	CW
				L	H	L	H	CCW
-	L	X	H	H	L	L	Brake	
			X	X	Z	Z	Standby	

L: Low, H: High, X: Don't care, Z: High Impedance

At CW, current flows from OUTA to OUTB. At CCW, current flows from OUTB to OUTA.

● I/O Circuit Diagram

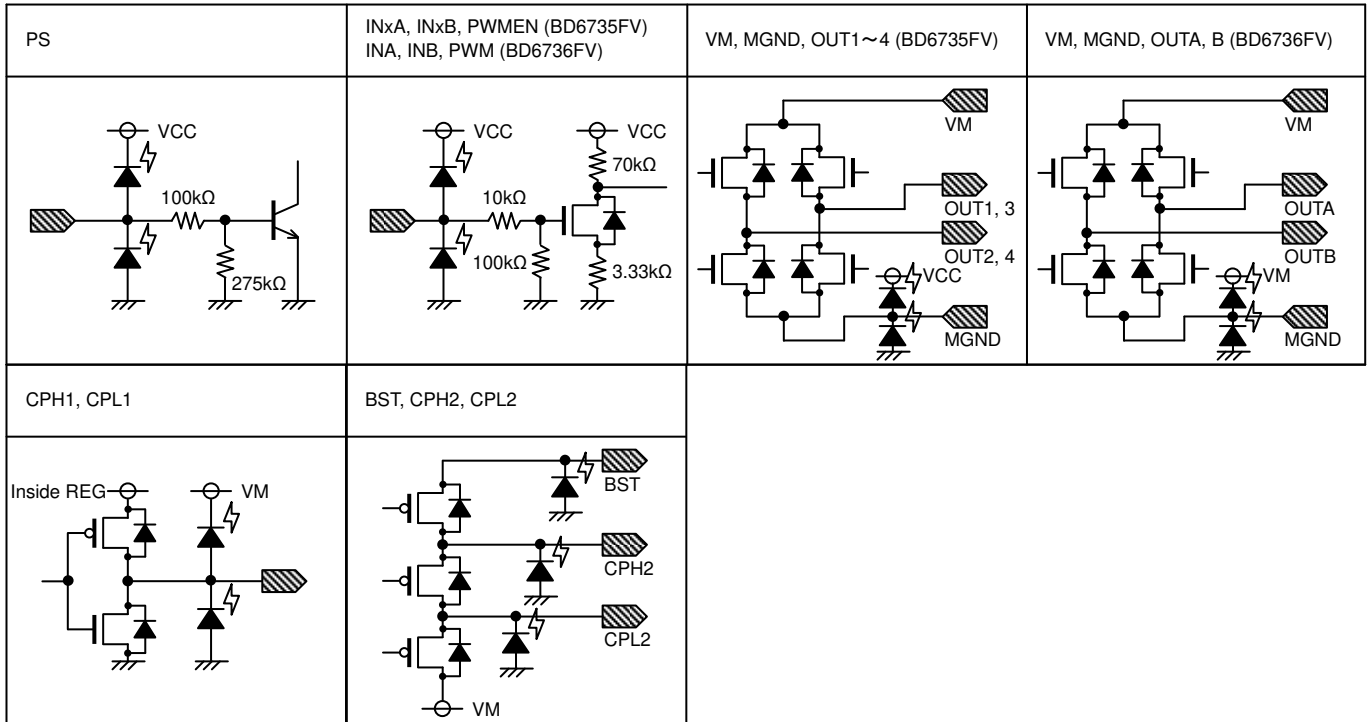

Fig.11 I/O Circuit Diagram (Resistance values are typical ones)

● Notes for use

1) Absolute maximum ratings

Use of the IC in excess of absolute maximum ratings such as the applied voltage or operating temperature range may result in IC damage. Assumptions should not be made regarding the state of the IC (short mode or open mode) when such damage is suffered. The implementation of a physical safety measure such as a fuse should be considered when use of the IC in a special mode where the absolute maximum ratings may be exceeded is anticipated.

2) Storage temperature range

As long as the IC is kept within this range, there should be no problems in the IC's performance. Conversely, extreme temperature changes may result in poor IC performance, even if the changes are within the above range.

3) Power supply pins and lines

None of the VM line for the H-bridges is internally connected to the VCC power supply line, which is only for the control logic or analog circuit. Therefore, the VM and VCC lines can be driven at different voltages. Although these lines can be connected to a common power supply, do not open the power supply pin but connect it to the power supply externally.

Regenerated current may flow as a result of the motor's back electromotive force. Insert capacitors between the power supply and ground pins to serve as a route for regenerated current. Determine the capacitance in full consideration of all the characteristics of the electrolytic capacitor, because the electrolytic capacitor may lose some capacitance at low temperatures. If the connected power supply does not have sufficient current absorption capacity, regenerative current will cause the voltage on the power supply line to rise, which combined with the product and its peripheral circuitry may exceed the absolute maximum ratings. It is recommended to implement a physical safety measure such as the insertion of a voltage clamp diode between the power supply and ground pins.

For this IC with 2 power supplies and a part consists of the CMOS block, it is possible that rush current may flow instantaneously due to the internal powering sequence and delays, and to the unstable internal logic, respectively. Therefore, give special consideration to power coupling capacitance, width of power and ground wirings, and routing of wiring.

4) Ground pins and lines

Ensure a minimum GND pin potential in all operating conditions. Make sure that no pins are at a voltage below the GND at any time, regardless of whether it is a transient signal or not.

When using both small signal GND and large current MGND patterns, it is recommended to isolate the two ground patterns, placing a single ground point at the application's reference point so that the pattern wiring resistance and voltage variations caused by large currents do not cause variations in the small signal ground voltage. Be careful not to change the GND wiring pattern of any external components, either.

The power supply and ground lines must be as short and thick as possible to reduce line impedance.

5) Thermal design

Use a thermal design that allows for a sufficient margin in light of the power dissipation (Pd) in actual operating conditions.

6) Pin short and wrong direction assembly of the device

Use caution when positioning the IC for mounting on printed circuit boards. The IC may be damaged if there is any connection error or if positive and ground power supply terminals are reversed. The IC may also be damaged if pins are shorted together or are shorted to other circuit's power lines.

7) Actions in strong magnetic field

Use caution when using the IC in the presence of a strong magnetic field as doing so may cause the IC to malfunction.

8) ASO

When using the IC, set the output transistor for the motor so that it does not exceed absolute maximum ratings or ASO.

9) Thermal shutdown circuit

If the junction temperature (T_{jmax}) reaches 175°C (BD6735FV Typ.) and 160°C (BD6736FV Typ.), the TSD circuit will operate, and the coil output circuit of the motor will open. There is a temperature hysteresis of approximately 20°C. The TSD circuit is designed only to shut off the IC in order to prevent runaway thermal operation. It is not designed to protect the IC or guarantee its operation. The performance of the IC's characteristics is not guaranteed and it is recommended that the device is replaced after the TSD is activated.

10) Testing on application board

When testing the IC on an application board, connecting a capacitor to a pin with low impedance subjects the IC to stress. Always discharge capacitors after each process or step. Always turn the IC's power supply off before connecting it to, or removing it from a jig or fixture, during the inspection process. Ground the IC during assembly steps as an antistatic measure. Use similar precaution when transporting and storing the IC.

11) Application example

The application circuit is recommended for use. Make sure to confirm the adequacy of the characteristics. When using the circuit with changes to the external circuit constants, make sure to leave an adequate margin for external components including static and transitional characteristics as well as dispersion of the IC.

12) Regarding input pin of the IC

This monolithic IC contains P⁺ isolation and P substrate layers between adjacent elements to keep them isolated. P-N junctions are formed at the intersection of these P layers with the N layers of other elements, creating a parasitic diode or transistor. For example, the relation between each potential is as follows:

When GND > Pin A, the P-N junction operates as a parasitic diode.

When GND > Pin B, the P-N junction operates as a parasitic diode and transistor.

Parasitic elements can occur inevitably in the structure of the IC. The operation of parasitic elements can result in mutual interference among circuits, operational faults, or physical damage. Accordingly, methods by which parasitic elements operate, such as applying a voltage that is lower than the GND (P substrate) voltage to an input pin, should not be used.

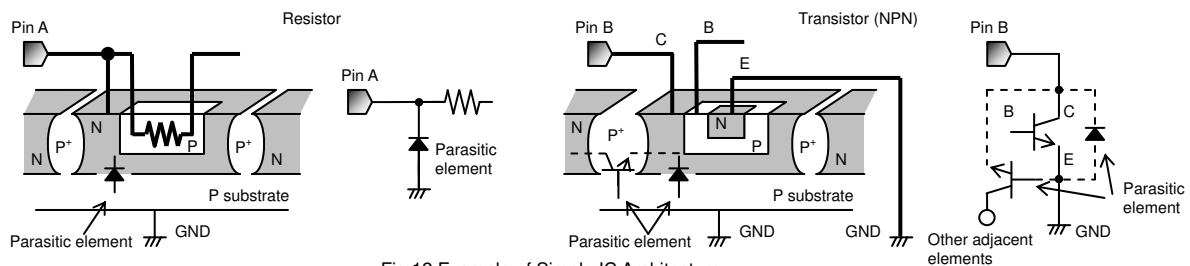

Fig.12 Example of Simple IC Architecture

●Ordering part number

B	D
---	---

Part No.

6	7	3	5
---	---	---	---

Part No.
 6735 : 8.0V power supply voltage
 6736 : 9.0V power supply voltage
 3.2A peak current

F	V
---	---

Package
 FV : SSOP-B20

E	2
---	---

Packaging and forming specification
 E2: Embossed tape and reel

SSOP-B20

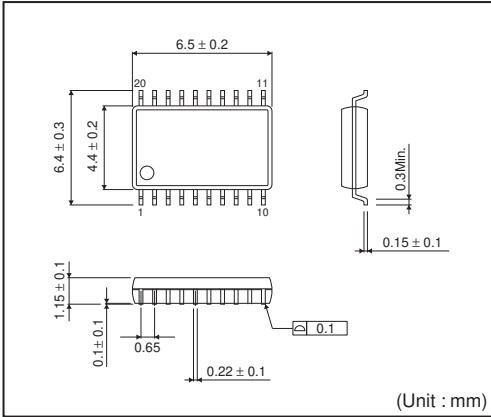

<Tape and Reel information>

Tape	Embossed carrier tape
Quantity	2500pcs
Direction of feed	E2 (The direction is the 1 pin of product is at the upper left when you hold reel on the left hand and you pull out the tape on the right hand)

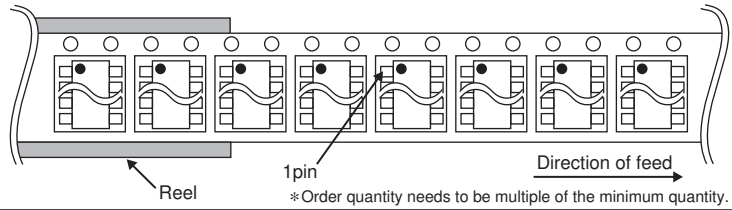

Notes

No copying or reproduction of this document, in part or in whole, is permitted without the consent of ROHM Co.,Ltd.

The content specified herein is subject to change for improvement without notice.

The content specified herein is for the purpose of introducing ROHM's products (hereinafter "Products"). If you wish to use any such Product, please be sure to refer to the specifications, which can be obtained from ROHM upon request.

Examples of application circuits, circuit constants and any other information contained herein illustrate the standard usage and operations of the Products. The peripheral conditions must be taken into account when designing circuits for mass production.

Great care was taken in ensuring the accuracy of the information specified in this document. However, should you incur any damage arising from any inaccuracy or misprint of such information, ROHM shall bear no responsibility for such damage.

The technical information specified herein is intended only to show the typical functions of and examples of application circuits for the Products. ROHM does not grant you, explicitly or implicitly, any license to use or exercise intellectual property or other rights held by ROHM and other parties. ROHM shall bear no responsibility whatsoever for any dispute arising from the use of such technical information.

The Products specified in this document are intended to be used with general-use electronic equipment or devices (such as audio visual equipment, office-automation equipment, communication devices, electronic appliances and amusement devices).

The Products specified in this document are not designed to be radiation tolerant.

While ROHM always makes efforts to enhance the quality and reliability of its Products, a Product may fail or malfunction for a variety of reasons.

Please be sure to implement in your equipment using the Products safety measures to guard against the possibility of physical injury, fire or any other damage caused in the event of the failure of any Product, such as derating, redundancy, fire control and fail-safe designs. ROHM shall bear no responsibility whatsoever for your use of any Product outside of the prescribed scope or not in accordance with the instruction manual.

The Products are not designed or manufactured to be used with any equipment, device or system which requires an extremely high level of reliability the failure or malfunction of which may result in a direct threat to human life or create a risk of human injury (such as a medical instrument, transportation equipment, aerospace machinery, nuclear-reactor controller, fuel-controller or other safety device). ROHM shall bear no responsibility in any way for use of any of the Products for the above special purposes. If a Product is intended to be used for any such special purpose, please contact a ROHM sales representative before purchasing.

If you intend to export or ship overseas any Product or technology specified herein that may be controlled under the Foreign Exchange and the Foreign Trade Law, you will be required to obtain a license or permit under the Law.



Thank you for your accessing to ROHM product informations.
More detail product informations and catalogs are available, please contact us.

ROHM Customer Support System

<http://www.rohm.com/contact/>