



Chipsmall Limited consists of a professional team with an average of over 10 year of expertise in the distribution of electronic components. Based in Hongkong, we have already established firm and mutual-benefit business relationships with customers from,Europe,America and south Asia,supplying obsolete and hard-to-find components to meet their specific needs.

With the principle of “Quality Parts,Customers Priority,Honest Operation,and Considerate Service”,our business mainly focus on the distribution of electronic components. Line cards we deal with include Microchip,ALPS,ROHM,Xilinx,Pulse,ON,Everlight and Freescale. Main products comprise IC,Modules,Potentiometer,IC Socket,Relay,Connector.Our parts cover such applications as commercial,industrial, and automotives areas.

We are looking forward to setting up business relationship with you and hope to provide you with the best service and solution. Let us make a better world for our industry!



Contact us

Tel: +86-755-8981 8866 Fax: +86-755-8427 6832

Email & Skype: info@chipsmall.com Web: www.chipsmall.com

Address: A1208, Overseas Decoration Building, #122 Zhenhua RD., Futian, Shenzhen, China



DC Brushless Motor Drivers for Fans

Multifunction Single-phase Full-wave Fan Motor Driver

BD69740FV

Description

BD69740FV is a pre-driver that controls the motor drive part composed of the power transistors. It incorporates current limiting circuit, lock protection and automatic restart circuit, PWM soft switching circuit, soft start circuit, and quick start circuit. The pin is compatible with BD69730FV (rotation speed pulse signal output).

Features

- Pre-driver for external power transistors
- Speed controllable by DC / direct PWM input
- PWM soft switching
- Soft start
- Quick start
- Current limit
- Lock protection and automatic restart
- Lock alarm signal (AL) output

Applications

- Fan motors for general consumer equipment of desktop PC, and Server, etc.

Package

SSOP-B16

W(Typ) x D(Typ) x H(Max)
5.00mm x 6.40mm x 1.35mm

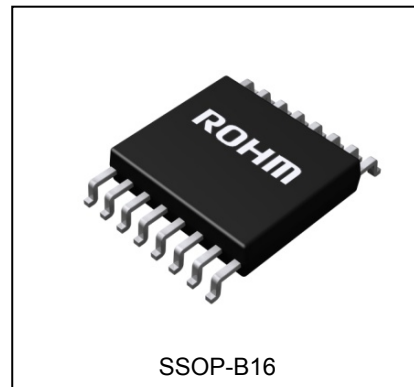

Absolute Maximum Ratings

Parameter	Symbol	Rating	Unit
Supply Voltage	V_{CC}	20	V
Power Dissipation	P_d	0.87 ^(Note 1)	W
Operating Temperature	T_{opr}	-40 to +105	°C
Storage Temperature	T_{stg}	-55 to +150	°C
Junction Temperature	T_{jmax}	150	°C
High side output voltage	V_{OH}	36	V
Low side output voltage	V_{OL}	15	V
Low side output current	I_{OL}	10	mA
Lock alarm signal (AL) output voltage	V_{AL}	20	V
Lock alarm signal (AL) output current	I_{AL}	10	mA
Reference voltage (REF) output current	I_{REF}	12	mA
Hall bias (HB) output current	I_{HB}	12	mA
Input voltage (H+, H-, TH, MIN, CS)	V_{IN}	7	V

(Note 1) Reduce by 7.0mW/°C over 25°C. (On 70.0mm×70.0mm×1.6mm glass epoxy board)

Caution: Operating the IC over the absolute maximum ratings may damage the IC. The damage can either be a short circuit between pins or an open circuit between pins and the internal circuitry. Therefore, it is important to consider circuit protection measures, such as adding a fuse, in case the IC is operated over the absolute maximum ratings.

Recommended Operating Conditions

Parameter	Symbol	Min	Typ	Max	Unit
Supply Voltage	V _{CC}	4.3	12	17	V
Hall Input Voltage1 (more than V _{CC} =9V)	V _{H1}	0	-	7	V
Hall Input Voltage2 (less than V _{CC} =9V)	V _{H2}	0	-	V _{CC} -2	V
HALL Signal Level	V _{HAMP}	±100	-	±500	mV
Operating Input Voltage (TH, MIN)	V _{IN}	0	-	V _{REF}	V

Electrical Characteristics (Unless otherwise specified Ta=25°C, V_{CC}=12V)

Parameter	Symbol	Min	Typ	Max	Unit	Conditions	Characteristics
Circuit Current	I _{CC}	3	5	8	mA		Figure 1
Hall Input Hysteresis Voltage	V _{HYS}	±5	±10	±15	mV		Figure 2
High Side Output Current	I _{OH}	9.0	12.0	16.5	mA	V _{OH} =12V	Figure 3
High Side Output Leak Current	I _{OH} L	-	-	10	μA	V _{OH} =36V	Figure 4
Low Side Output High Voltage	V _{OLH}	9.3	9.5	-	V	I _{OL} =-5mA	Figure 5,6
Low Side Output Low Voltage	V _{OLL}	-	0.5	0.7	V	I _{OL} =5mA	Figure 7,8
Lock Detection ON Time	t _{ON}	0.20	0.30	0.45	s		Figure 9
Lock Detection OFF Time	t _{OFF}	4.0	6.0	9.0	s		Figure 10
AL Output Low Voltage	V _{ALL}	-	-	0.3	V	I _{AL} =5mA	Figure 11,12
AL Output Leak Current	I _{ALL}	-	-	10	μA	V _{AL} =17V	Figure 13
OSC High Voltage	V _{OSCH}	2.3	2.5	2.7	V		Figure 14
OSC Low Voltage	V _{OSCL}	0.8	1.0	1.2	V		Figure 14
OSC Charge Current	I _{CO} SC	-55	-40	-25	μA		Figure 15
OSC Discharge Current	I _{DO} SC	25	40	55	μA		Figure 15
Output ON Duty 1	P _{OH1}	75	80	85	%	V _{TH} =V _{REF} × 0.26 H side pull up R=1kΩ, OSC=470pF	-
Output ON Duty 2	P _{OH2}	45	50	55	%	V _{TH} =V _{REF} × 0.35 H side pull up R=1kΩ, OSC=470pF	-
Output ON Duty 3	P _{OH3}	15	20	25	%	V _{TH} =V _{REF} × 0.44 H side pull up R=1kΩ, OSC=470pF	-
Reference Voltage	V _{REF}	4.8	5.0	5.2	V	I _{REF} =-2mA	Figure 16,17
Hall Bias Voltage	V _{HB}	1.10	1.26	1.50	V	I _{HB} =-2mA	Figure 18,19
Current Limit Setting Voltage	V _{CL}	120	150	180	mV		Figure 20
SS Charge Current	I _{SS}	-300	-120	-50	nA	V _{SS} =0V	Figure 21
TH Input Bias Current	I _{TH}	-	-	-0.2	μA	V _{TH} =0V	Figure 22
MIN Input Bias Current	I _{MIN}	-	-	-0.2	μA	V _{MIN} =0V	Figure 23
CS Input Bias Current	I _{CS}	-	-	-0.2	μA	V _{CS} =0V	Figure 24

About a current item, define the inflow current to IC as a positive notation, and the outflow current from IC as a negative notation.

Truth Table

Hall Input		IC Output				Motor Drive Output	
H+	H-	A1H	A1L	A2H	A2L	OUT1	OUT2
H	L	Hi-Z	H	L	L	L	H
L	H	L	L	Hi-Z	H	H	L

Motor state	AL
Rotating	L
Locking	Hi-Z

H; High, L; Low, Hi-Z; High impedance
AL output is open-drain type.

Reference data

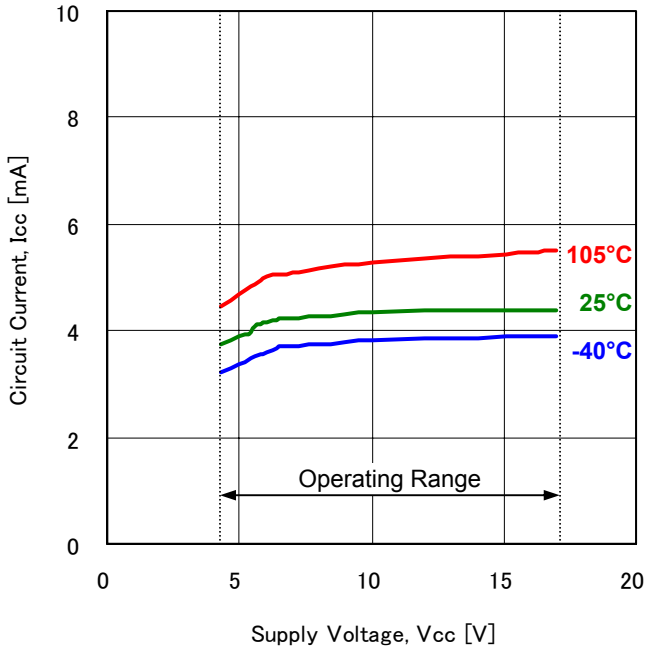

Figure 1. Circuit Current vs Supply Voltage

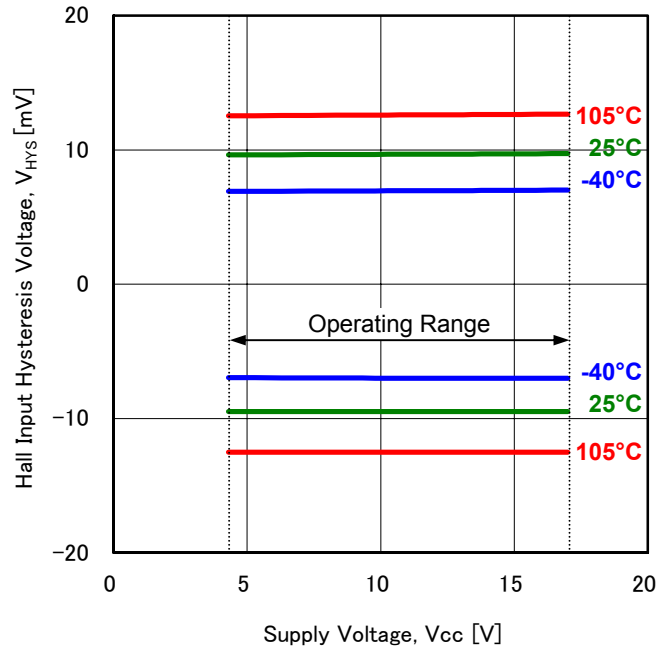

Figure 2. Hall Input Hysteresis Voltage vs Supply Voltage

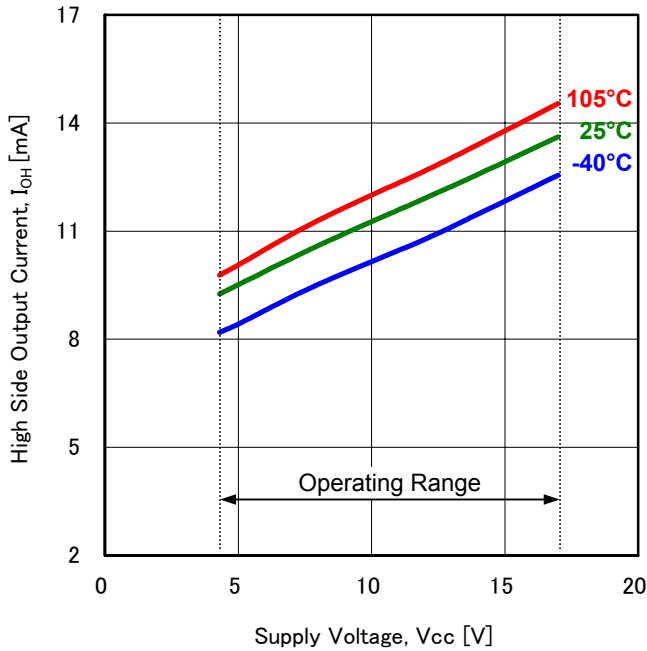

Figure 3. High Side Output Current vs Supply Voltage

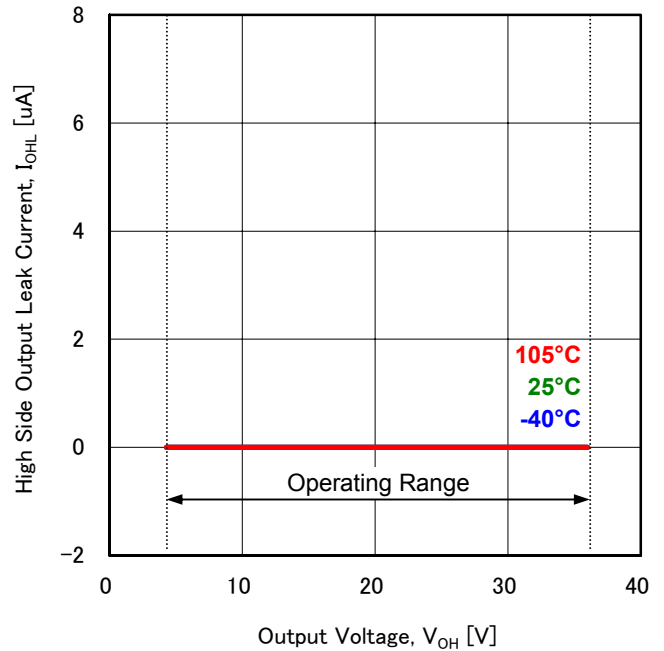

Figure 4. High Side Output Leak Current vs Output Voltage

Reference data- continued

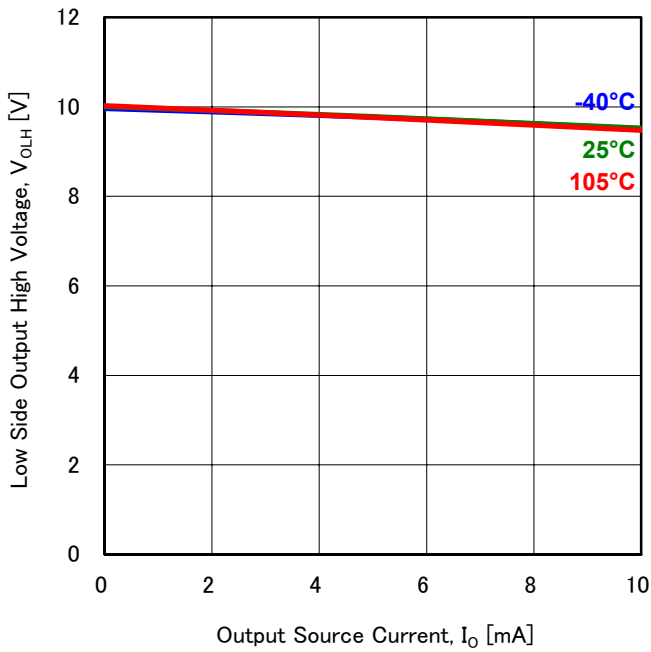

Figure 5. Low Side Output High Voltage vs Output Source Current (V_{cc}=12V)

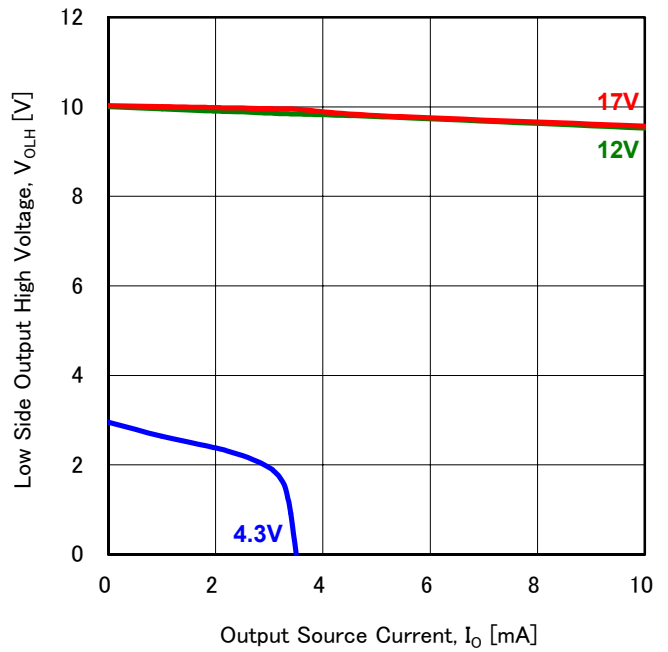

Figure 6. Low Side Output High Voltage vs Output Source Current (T_a=25°C)

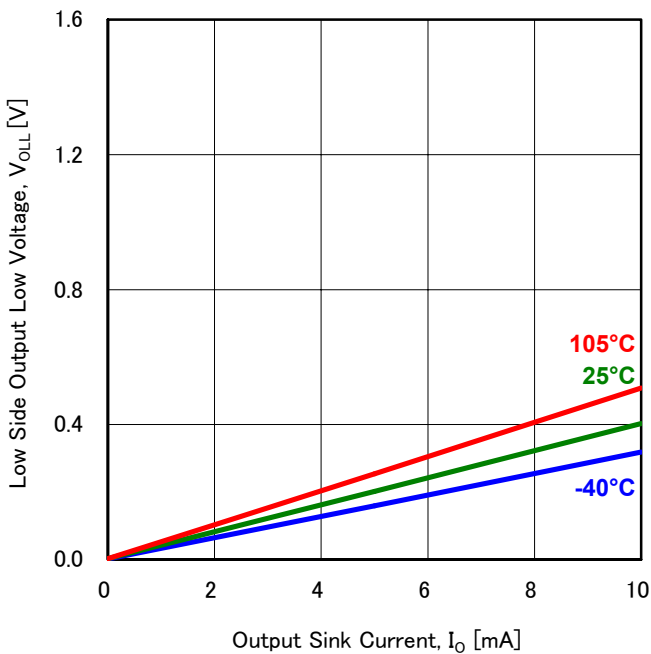

Figure 7. Low Side Output Low Voltage vs Output Sink Current (V_{cc}=12V)

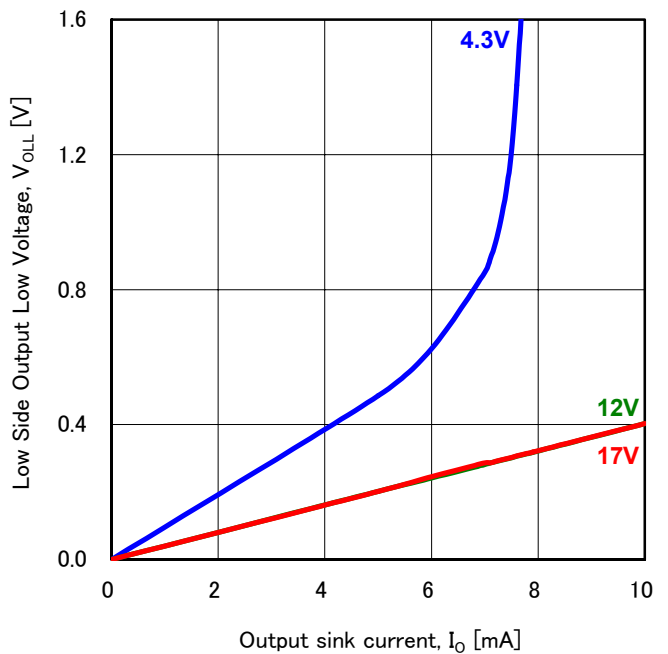

Figure 8. Low Side Output Low Voltage vs Output Sink Current (T_a=25°C)

Reference data- continued

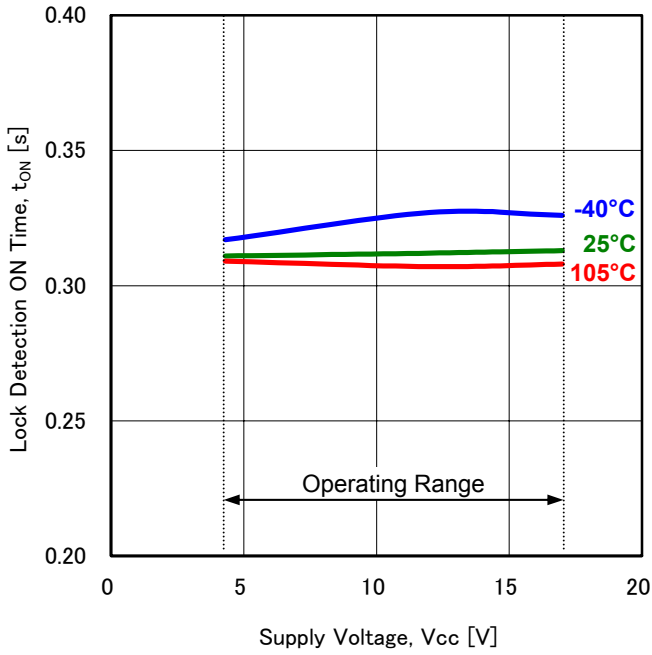

Figure 9. Lock Detection ON Time vs Supply Voltage

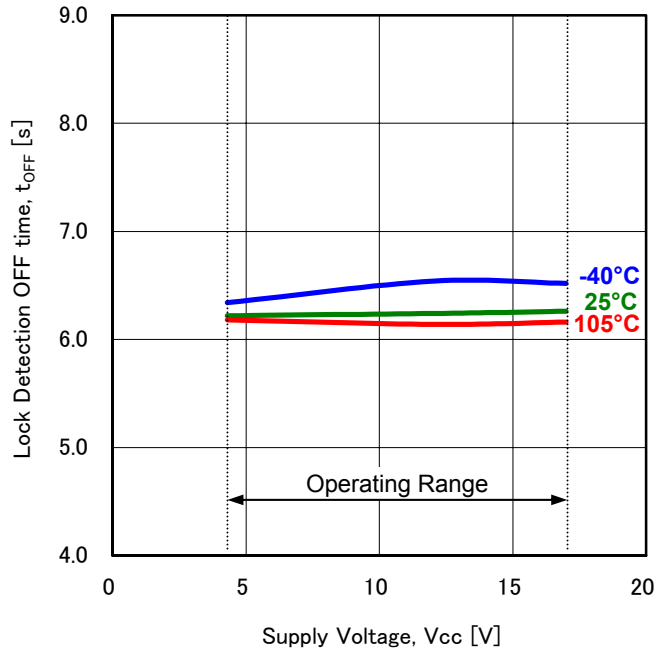

Figure 10. Lock Detection OFF Time vs Supply Voltage

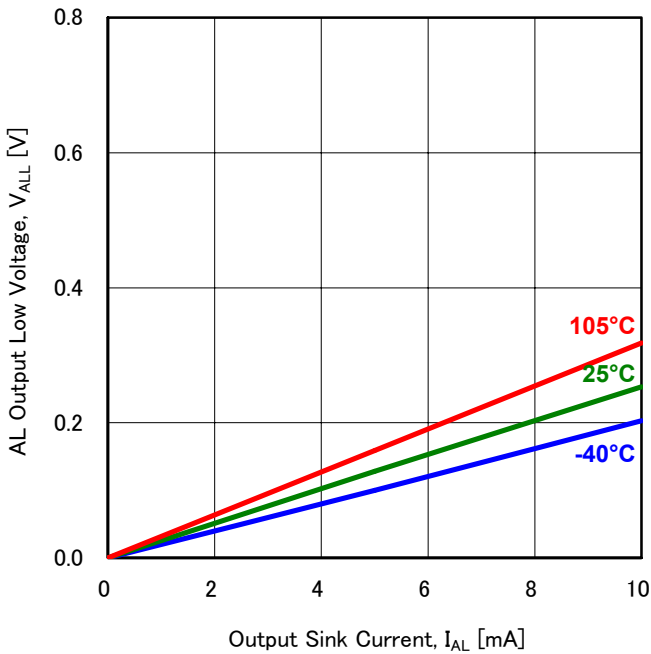

Figure 11. AL Output Low Voltage vs Output Sink Current (Vcc=12V)

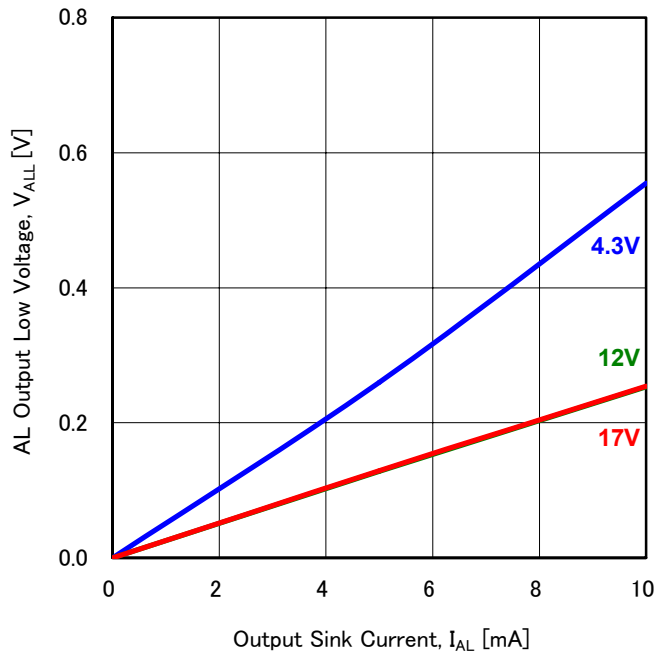

Figure 12. AL Output Low Voltage vs Output Sink Current (Ta=25°C)

Reference data- continued

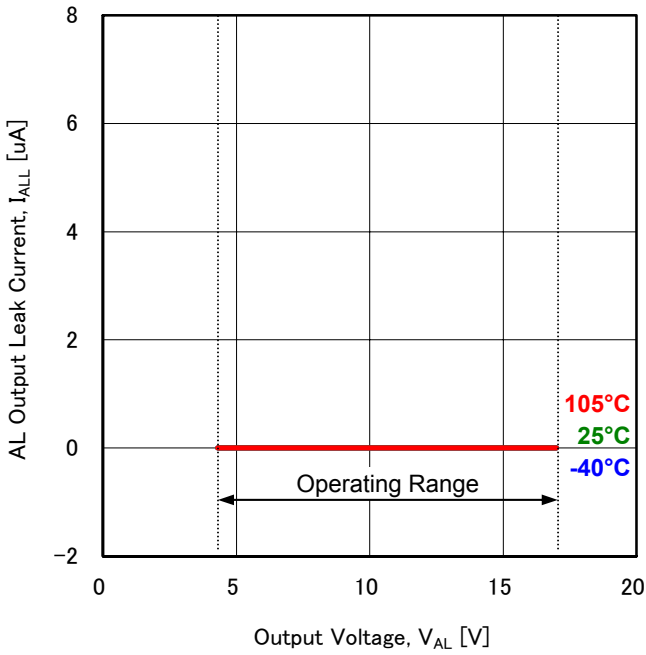

Figure 13. AL Output Leak Current vs Output Voltage

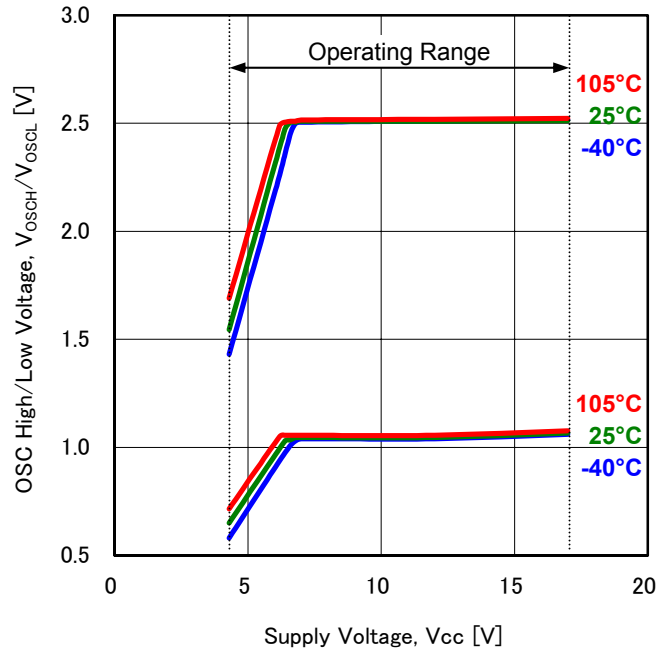

Figure 14. OSC High/Low Voltage vs Supply Voltage

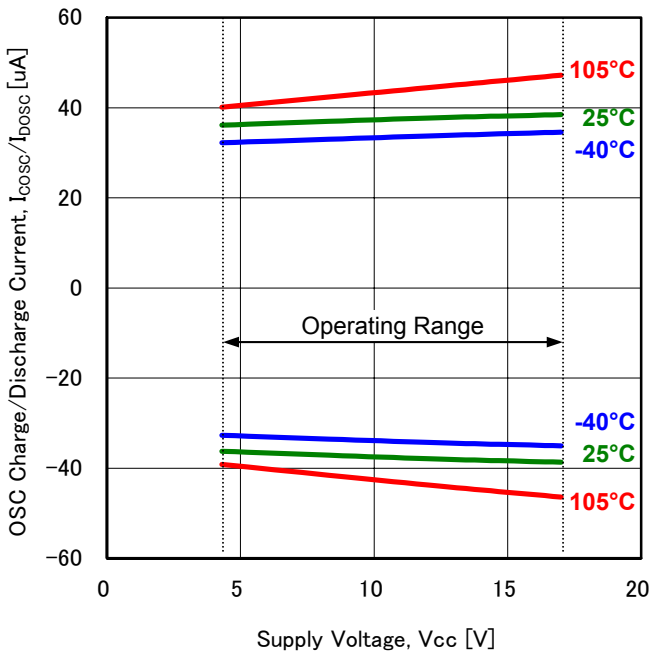

Figure 15. OSC Charge/Discharge Current vs Supply Voltage

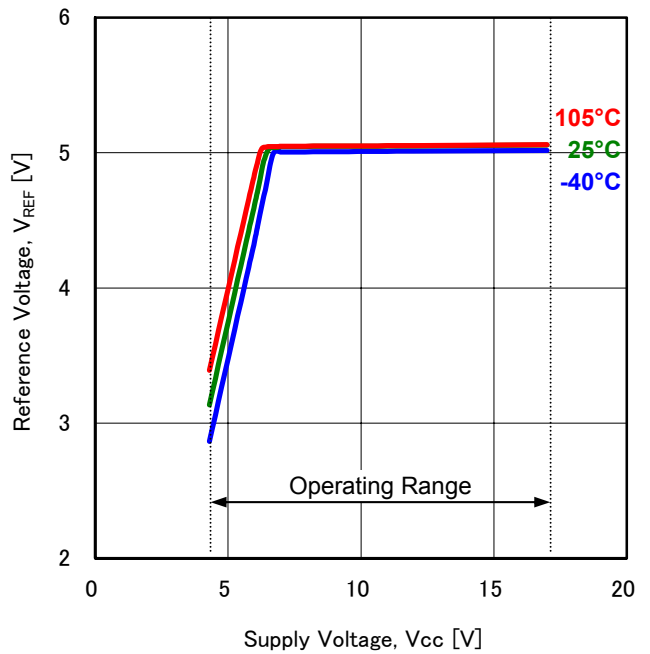

Figure 16. Reference Voltage vs Supply Voltage

Reference data- continued

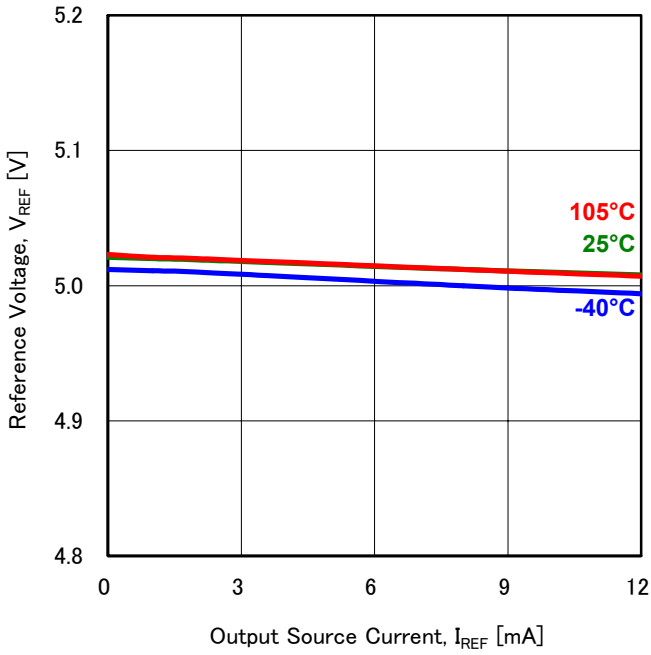

Figure 17. Reference Voltage vs Output Source Current ($V_{CC}=12V$)

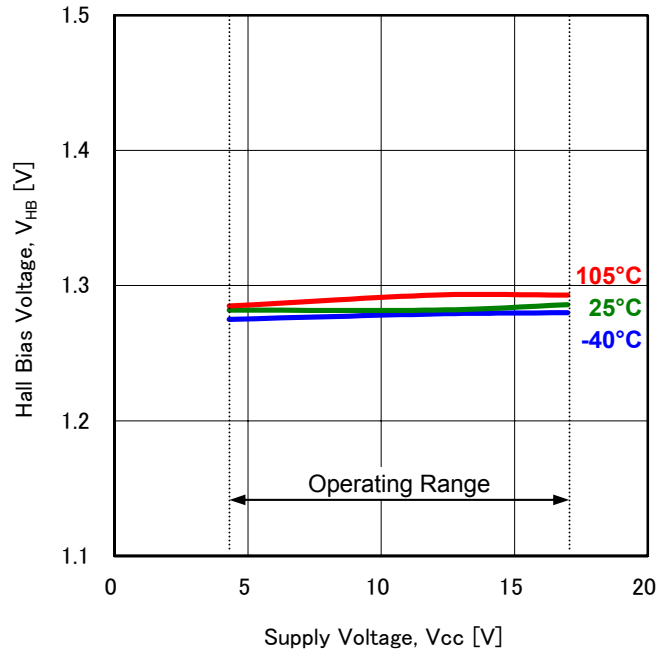

Figure 18. Hall Bias Voltage vs Supply Voltage

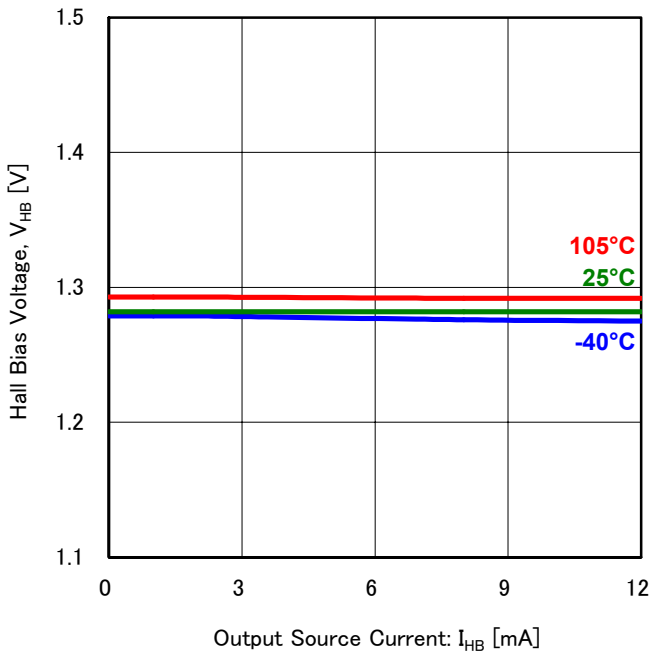

Figure 19. Hall Bias Voltage vs Output Source Current ($V_{CC}=12V$)

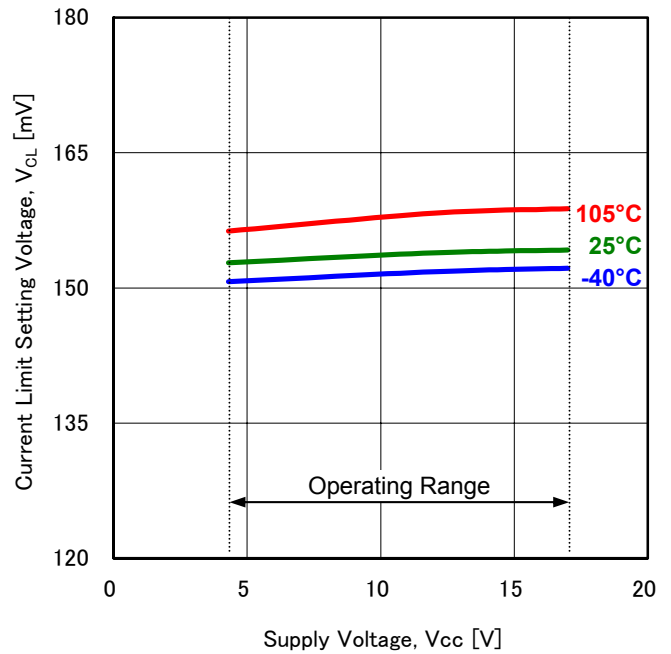

Figure 20. Current Limit Setting Voltage vs Supply Voltage

Reference data- continued

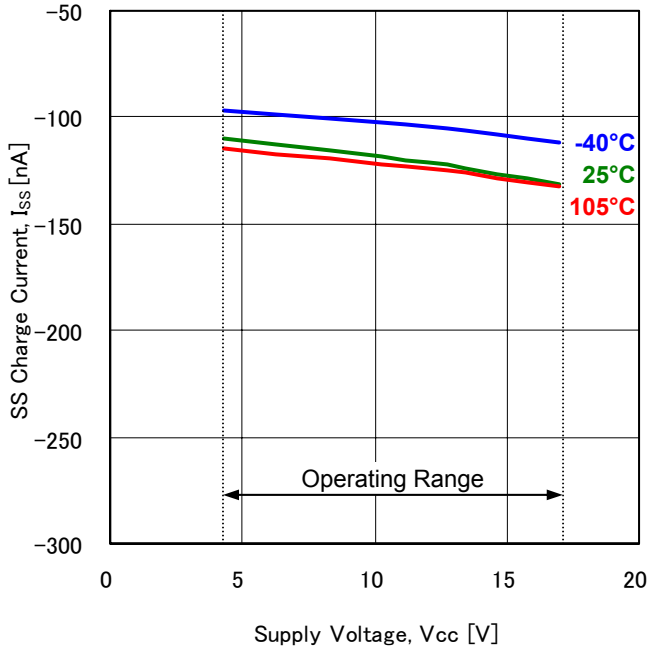

Figure 21. SS Charge Current vs Supply Voltage

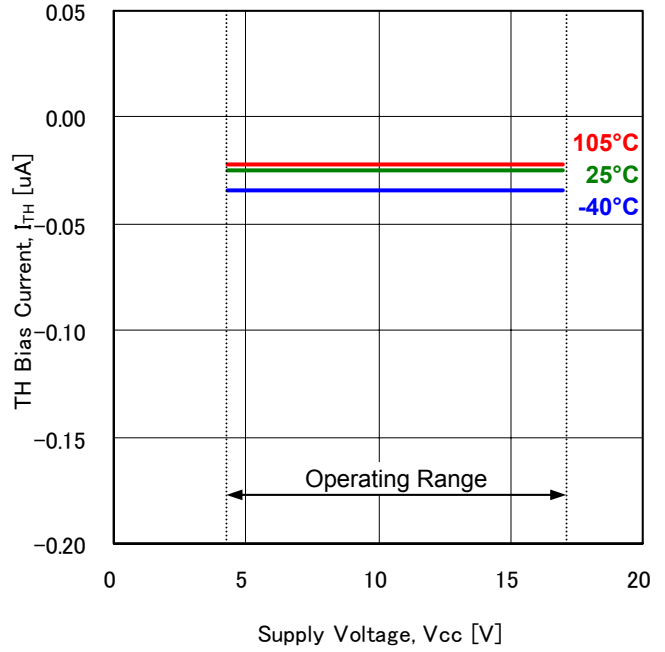

Figure 22. TH Bias Current vs Supply Voltage

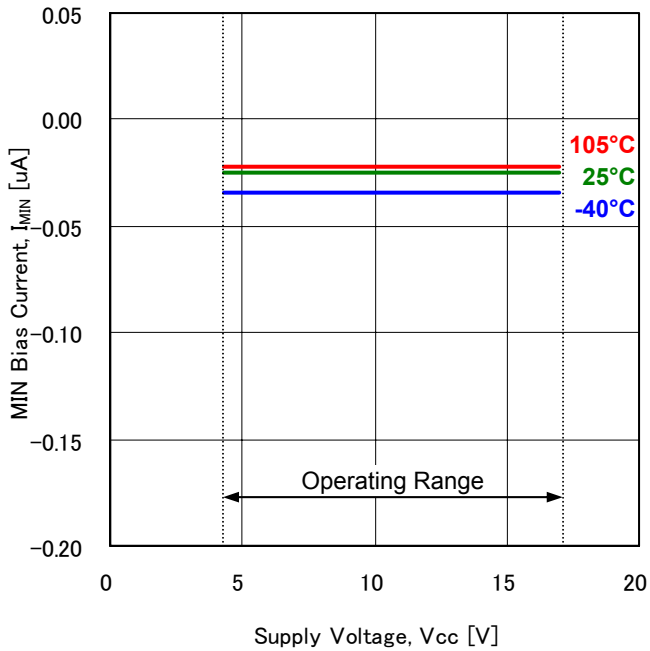

Figure 23. MIN Bias Current vs Supply Voltage

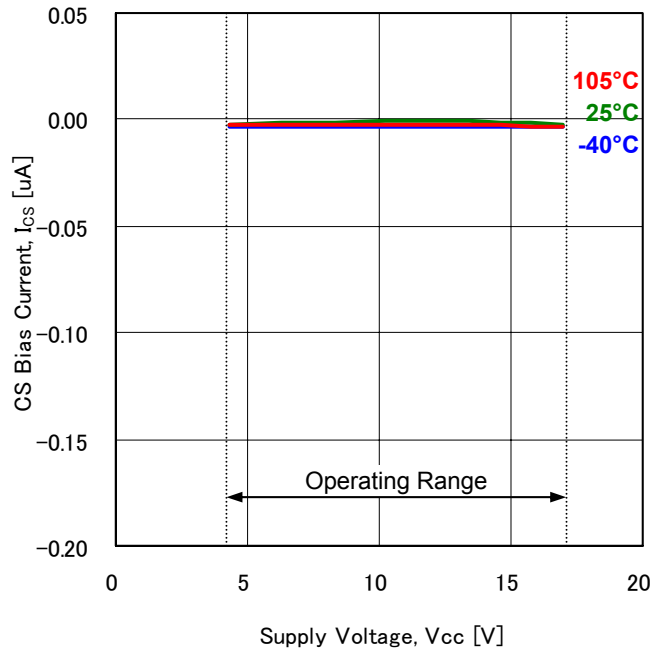
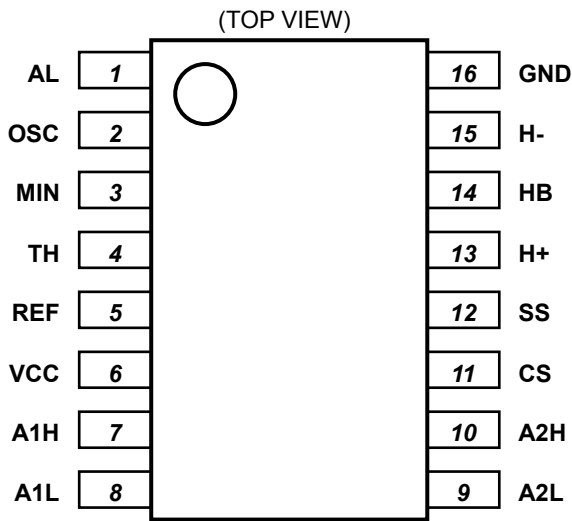
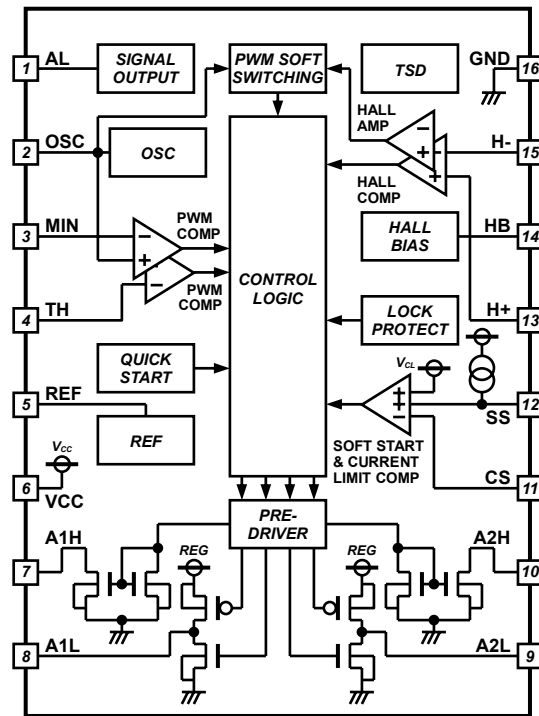

Figure 24. CS Bias Current vs Supply Voltage

Pin Configuration



Block Diagram



Pin Description

Pin No.	Pin Name	Function
1	AL	Lock alarm signal output pin
2	OSC	Oscillating capacitor connecting pin
3	MIN	Minimum output duty setting pin
4	TH	Output duty controllable input pin
5	REF	Reference voltage output pin
6	VCC	Power supply pin
7	A1H	High side output 1 pin
8	A1L	Low side output 1 pin
9	A2L	Low side output 2 pin
10	A2H	High side output 2 pin
11	CS	Output current detection pin
12	SS	Soft start capacitor connecting pin
13	H+	Hall + input pin
14	HB	Hall bias pin
15	H-	Hall - input pin
16	GND	Ground pin

Application circuit example(Constant values are for reference)

1) PWM input application 1

It is an example of the application of converting the external PWM duty into DC voltage, and controlling the rotational speed. Minimum rotational speed can be set.

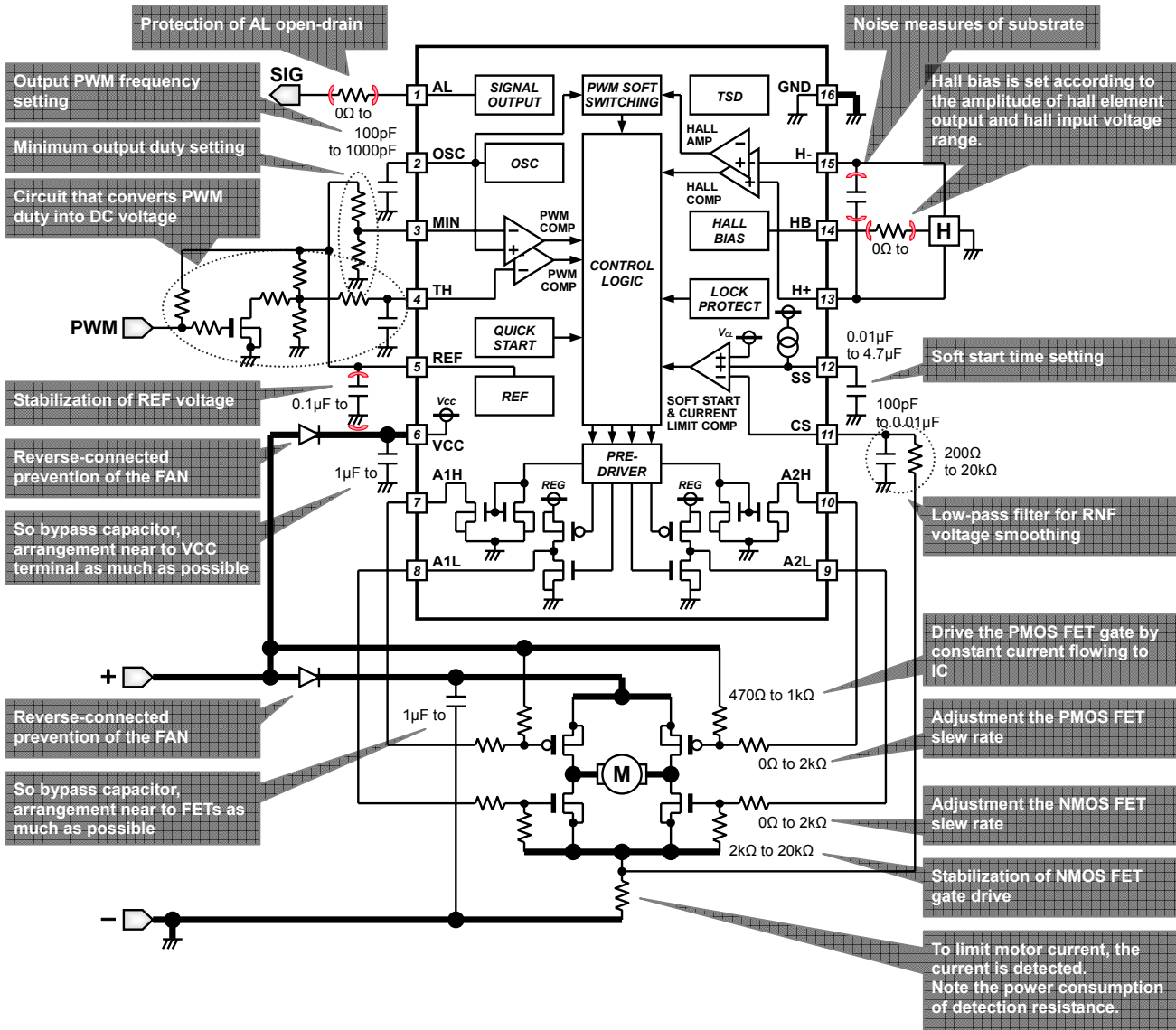

Figure 25. Application of converting PWM duty to DC voltage

Substrate design note

- Motor power and ground lines are made as fat as possible.
- IC power line is made as fat as possible.
- IC ground line is common with the application ground except motor ground (i.e. hall ground etc.), and arranged near to (-) land.
- The bypass capacitors (VCC side and VM side) are arrangement near to VCC terminal and FETs, respectively.
- H+ and H- lines are arranged side by side and made from the hall element to IC as shorter as possible, because it is easy for the noise to influence the hall lines.

Application circuit example(Constant values are for reference)

2) PWM input application 2

It is an example of the application of inverting the external PWM input, and controlling the rotational speed. In this application, if the external PWM input is OPEN, it controls by the set maximum rotational speed. Minimum rotational speed cannot be set.

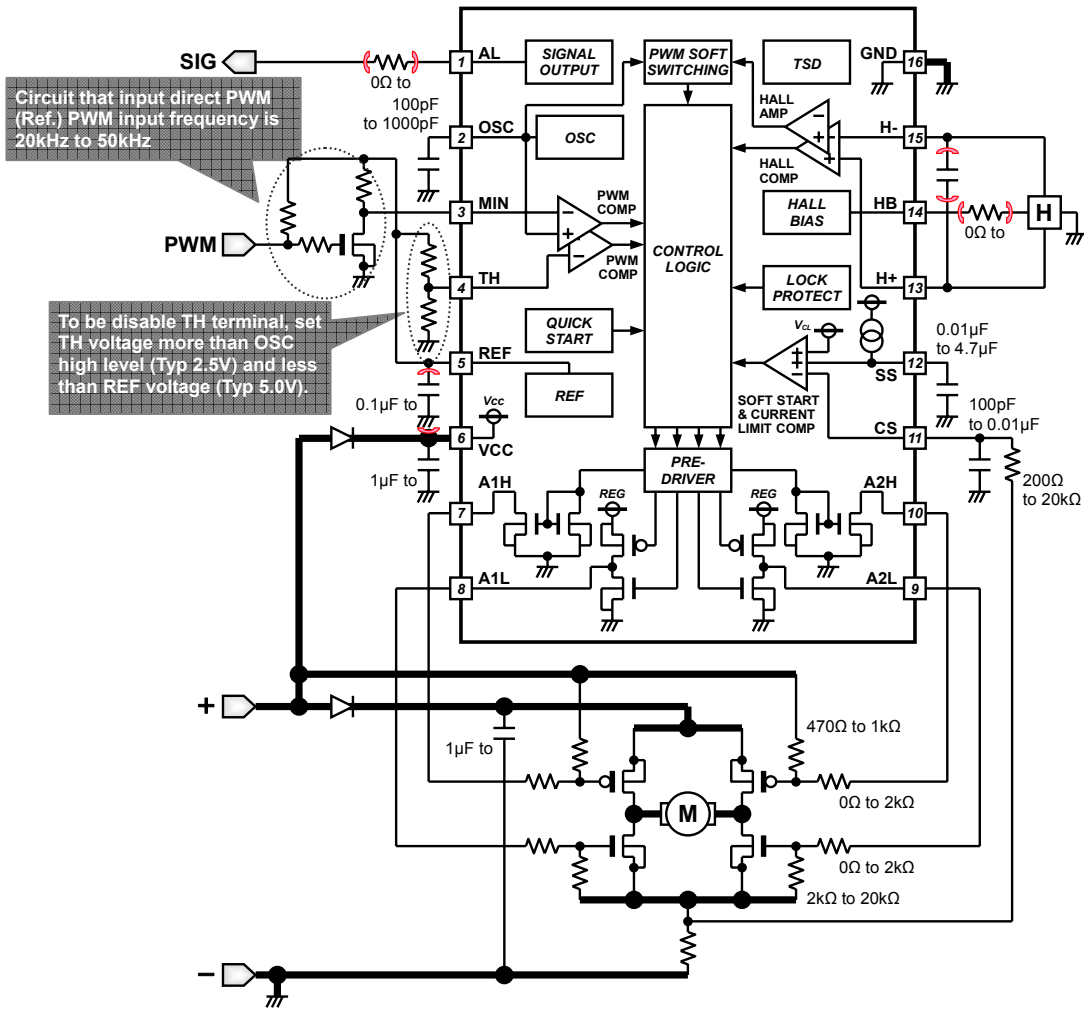

Figure 26. Application of direct PWM input

Application circuit example(Constant values are for reference)

3) DC voltage input application 1

It is an example of the application for the fixed rotation speed control by DC voltage. Minimum rotational speed cannot be set.

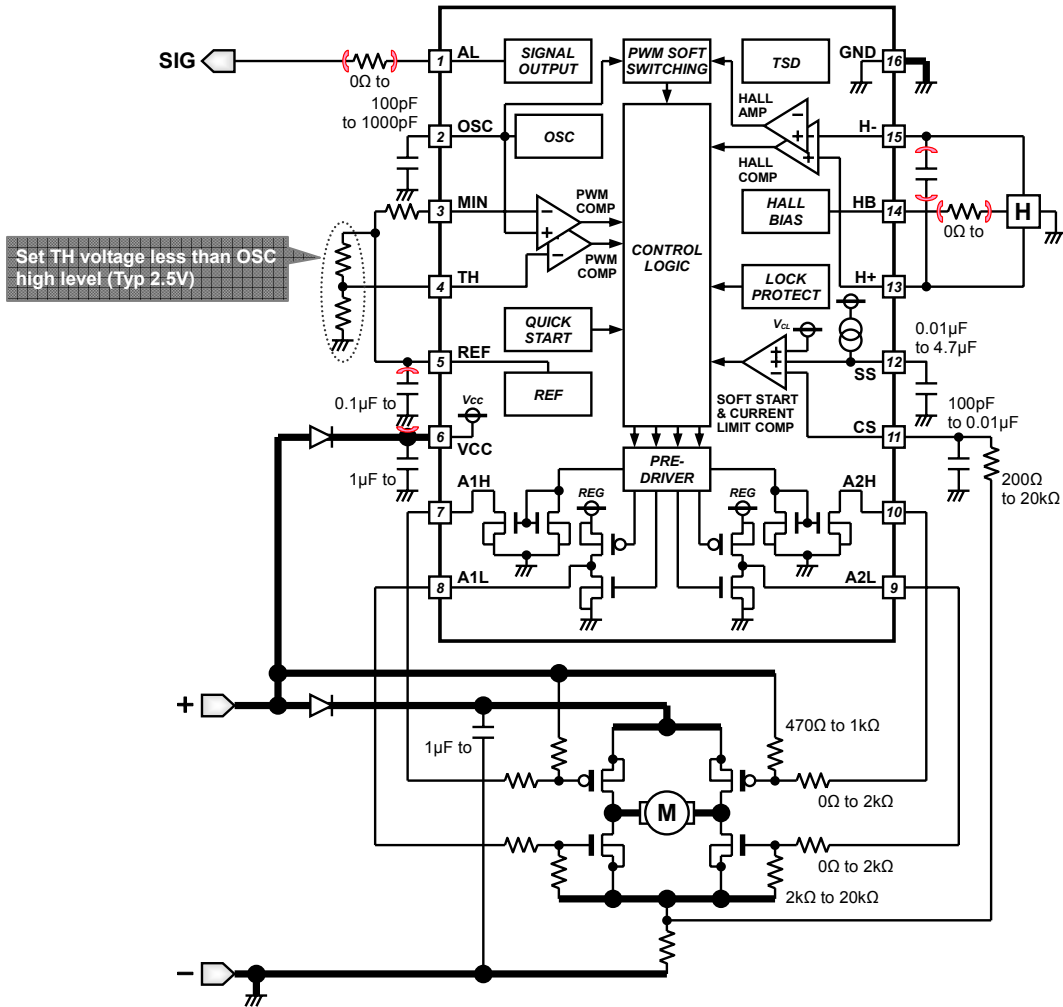

Figure 27. Application of DC voltage input

Application circuit example(Constant values are for reference)

4) DC voltage input application 2 (Thermistor control application)

It is an example of the application of controlling the rotational speed by the ambient temperature. In this application, if the thermistor is OPEN, it controls by the set maximum rotational speed.

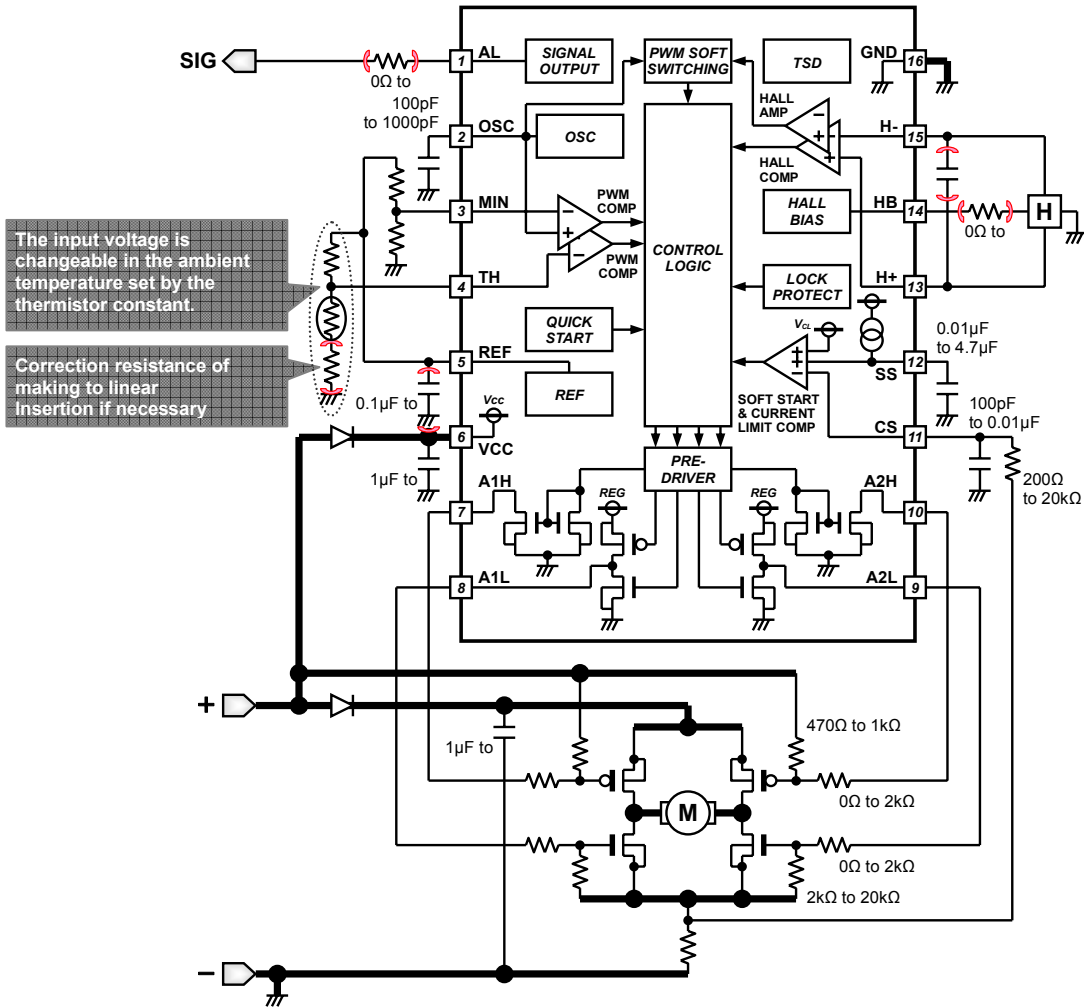

Figure 28. Application of thermistor control

Application circuit example(Constant values are for reference)

- 5) High voltage (24V power supply) application (PWM input application 1)
It is an example of the application of converting the external PWM duty into DC voltage, and controlling the rotational speed. Minimum rotational speed can be set.

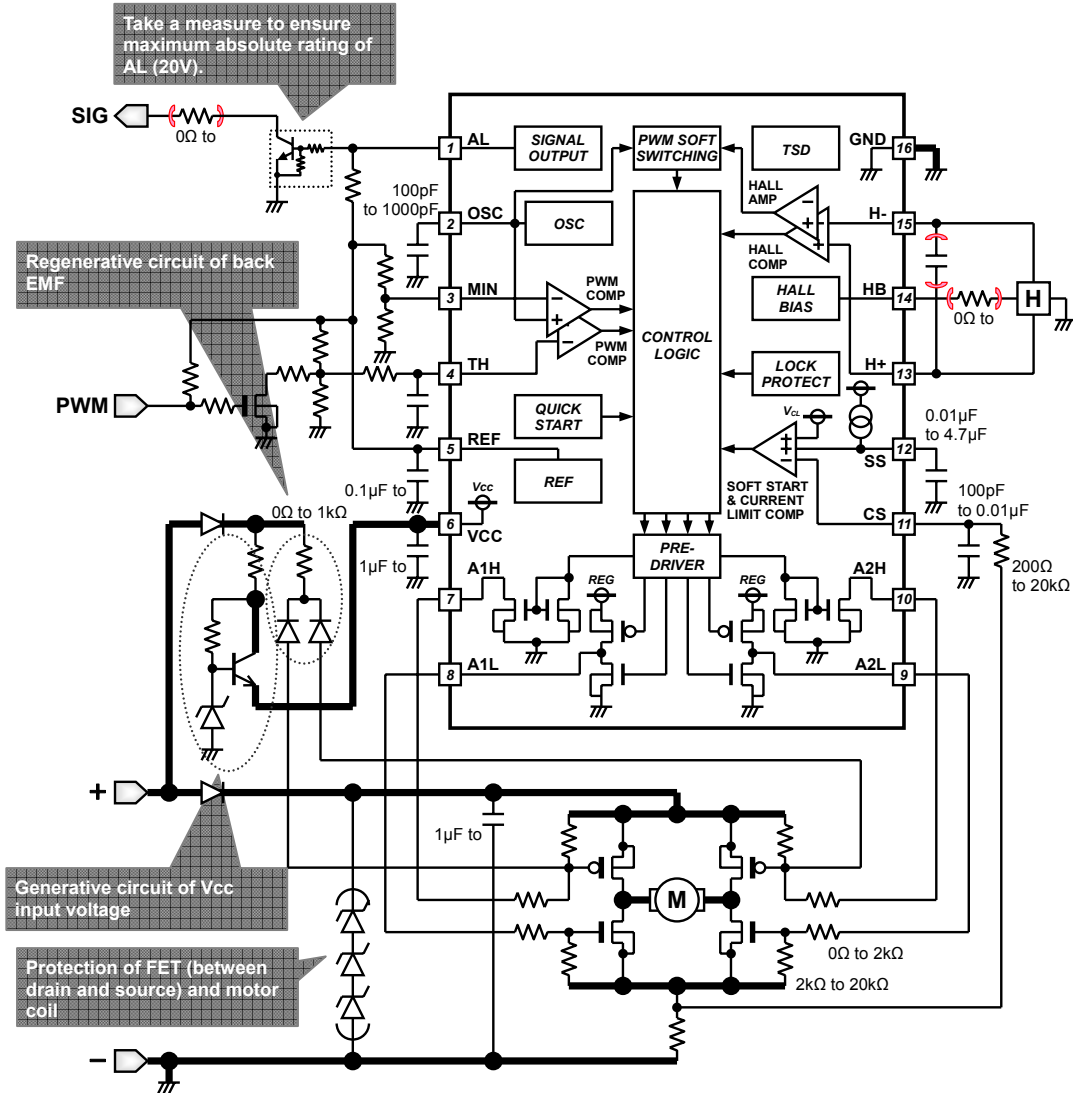

Figure 29. 24V power supply application of PWM input

Application circuit example(Constant values are for reference)

- 6) High voltage (over 48V power supply) application (PWM input application 1)
It is an example of the application of converting the external PWM duty into DC voltage, and controlling the rotational speed. Minimum rotational speed can be set.

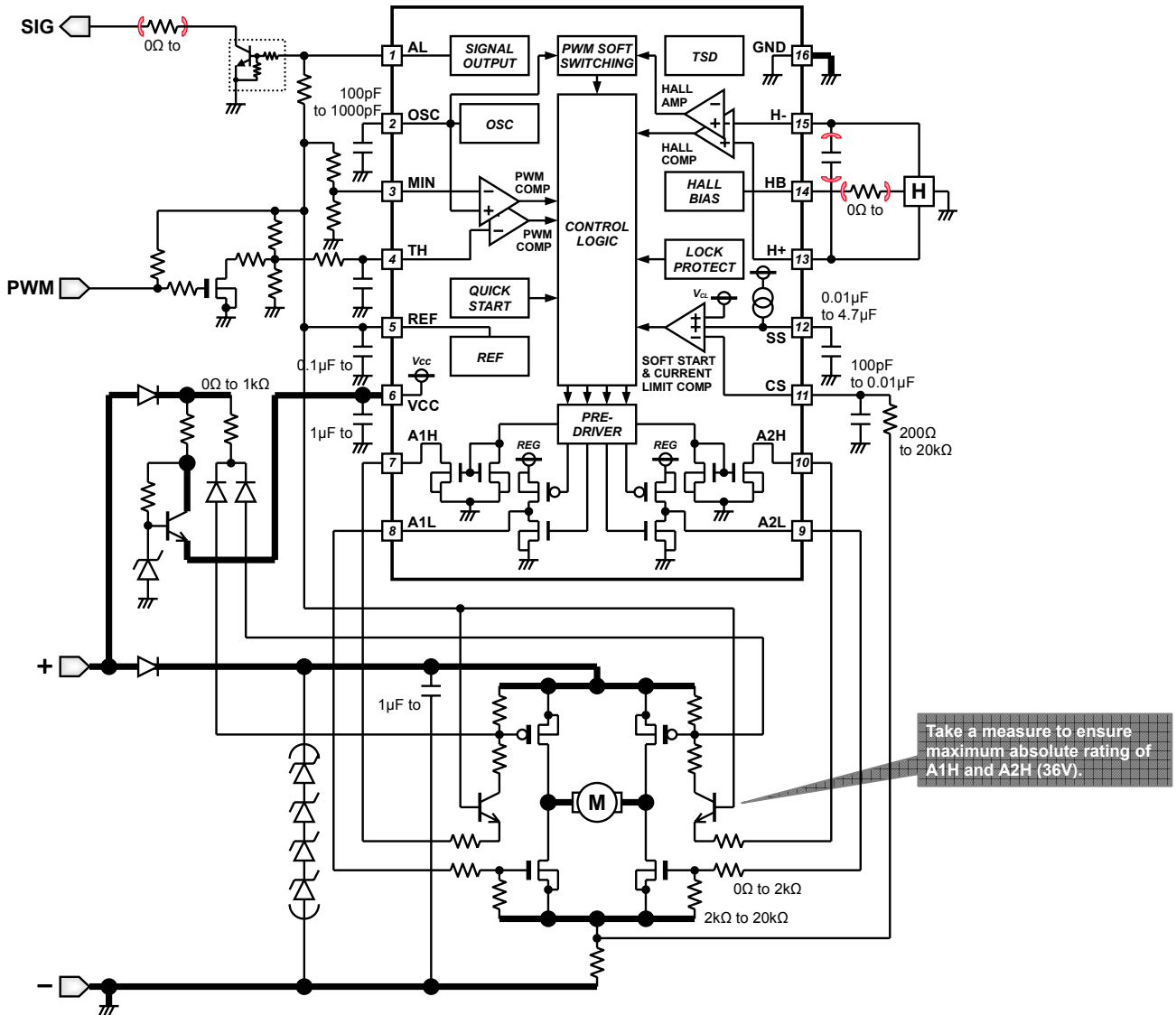

Figure 30. Over 48V power supply application of PWM input

Functional descriptions

1) Variable speed operation

Rotating speed changes by PWM duty on the high side outputs (A1H, A2H terminals). PWM operation enables,

- a) By DC voltage input in TH terminal, and MIN terminal
- b) By pulse input in MIN terminal

a) PWM operation by DC input

As shown in Figure 31, to change high side output ON duty, DC voltage input from TH terminal is compared with triangle wave produced by the OSC circuit. MIN terminal is for setting the minimum rotating speed. ON duty is determined by either TH terminal voltage or MIN terminal voltage, whichever is lower.

- OSC voltage > TH voltage (MIN voltage): high side output is ON
- OSC voltage < TH voltage (MIN voltage): high side output is OFF

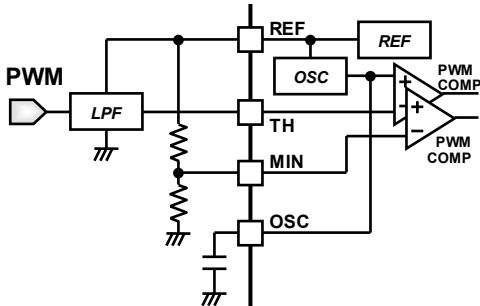

Figure 31. DC input application 1

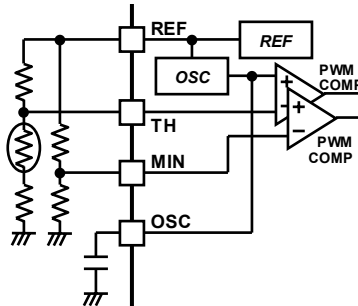

Figure 32. DC input application 2

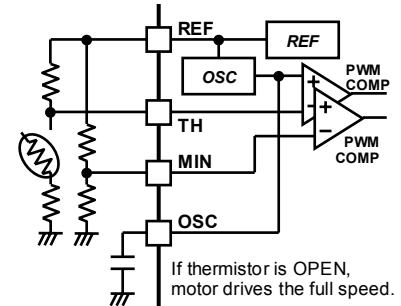

Figure 33. Protection for thermistor coming off

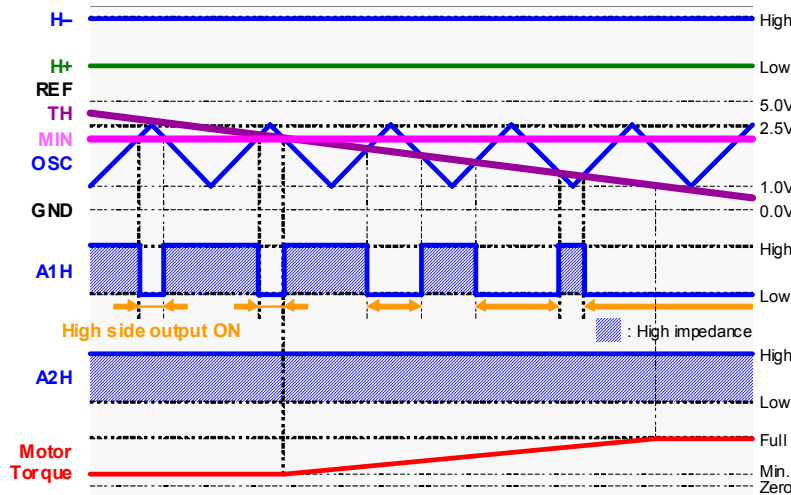

Figure 34. DC input operation timing chart

Dividing resistance of the internal regulator (equal to Typ 5.0V REF terminal) generates OSC high level (Typ 2.5V) and OSC low level (Typ 1.0V) voltage, and the ratio of those voltages is designed to be hard to fluctuate. When the input voltage at TH terminal is constant, effect by fluctuation of OSC H/L voltage is large. However, by setting that an application of REF voltage generates input voltage via TH, application can be made hard to be affected by voltage fluctuation of triangle wave. For an application that requires strict precision, determine a value with sufficient margin after full consideration of external constant is taken.

Protection against thermistor coming off

When the thermistor becomes an opening (the TH voltage is more than the REF voltage) as a protection function in the DC input application that uses the thermistor like Figure 33, it doesn't depend on the MIN voltage and it sets by the maximum rotation speed.

Setting of output oscillating frequency at DC voltage input

Frequency (Fosc) in which the high side outputs are operated PWM by DC voltage input is set according to capacity value (Cosc) of the capacitor connected with OSC terminal.

$$F_{osc}[\text{Hz}] = (|I_{Dosc}[\text{A}] \times I_{Cosc}[\text{A}]|) / \{C_{osc}[\text{F}] \times (|I_{Dosc}[\text{A}]| + |I_{Cosc}[\text{A}]|) \times (V_{OSCH}[\text{V}] - V_{OSCL}[\text{V}])\}$$

(ex.) The frequency when output PWM operates becomes about 28kHz when assuming that Cosc is 470pF.

$$F_{osc}[\text{Hz}] = \{40[\mu\text{A}] \times (-40[\mu\text{A}])\} / \{470[\text{pF}] \times (40[\mu\text{A}] + |-40[\mu\text{A}]) \times (2.5[\text{V}] - 1.0[\text{V}])\}$$

$$= 28369[\text{Hz}]$$

1) Variable speed operation – Continued

The voltage of the terminal becomes irregular as for TH or MIN terminals when opening, and input both voltages to both terminals when you turn on IC power supply (Vcc).

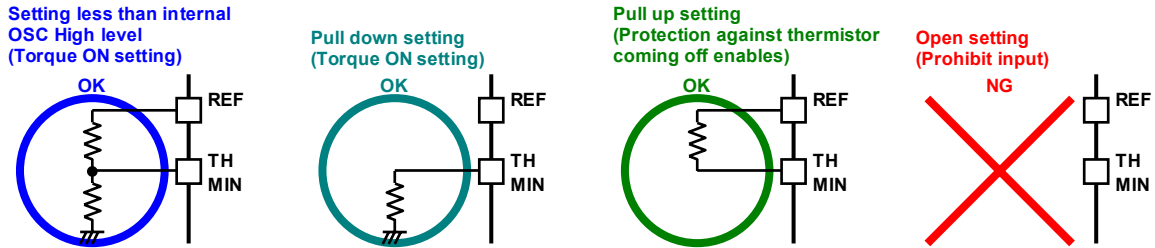

Figure 35. Setting of the variable speed function

b) PWM operation by pulse input

Pulse signal can be input to MIN terminal for PWM operation as shown in Figure 38. The ON duty of the high side output changes by the cycle of the input pulse signal as shown in Figure 38. The TH terminal is set more than OSC high level and less than REF voltage. Set the voltage of MIN terminal as,
 $REF \geq MIN > OSC$ high level: high side output is OFF
 $GND \leq MIN < OSC$ low level: high side output is ON

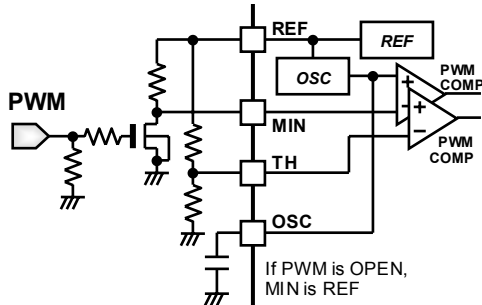

Figure 36. PWM input application 1

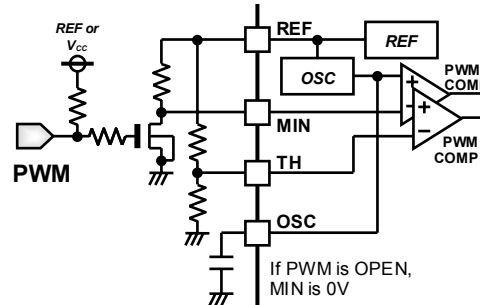

Figure 37. PWM input application 2

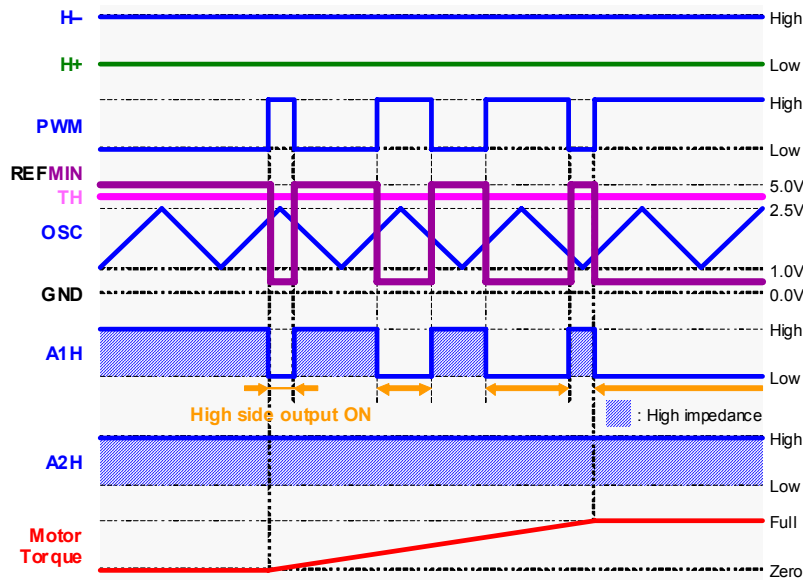

Figure 38. PWM input operation timing chart

2) Current limit

The current limit circuit turns off the output, when the current that flows to the motor coil is detected exceeding a set value. The current value that current limit operates is determined by internal setting voltage and voltage of CS terminal. In Figure 39, I_o is the current flowed to the motor coil, R_{NF} is the resistance detected the current, and P_R is the power consumption of R_{NF} . When $R_{NF}=0.1[\Omega]$, the current limit setting voltage (V_{CL}) is 150mV,

$$I_o[A] = V_{CL}[V] / R_{NF}[\Omega] \quad P_R[W] = V_{CL}[V] \times I_o[A]$$

$$= 150[mV] / 0.1[\Omega] \quad = 150[mV] \times 1.5[A]$$

$$= 1.5[A] \quad = 0.225[W]$$

Be shorted CS terminal to GND, when the current limit function is not used.

R_{CS} and C_{CS} consist of the low-pass filter for smoothing RNF voltage.

Share and assume the ground of C_{CS} to be the small signal ground line with the GND pin of IC for the malfunction prevention of a current limit. Separate with the motor large current ground line with which R_{NF} is connected. Soft start capacitor C_{SS} described later is similar. (Refer to P.10 substrate design note c)

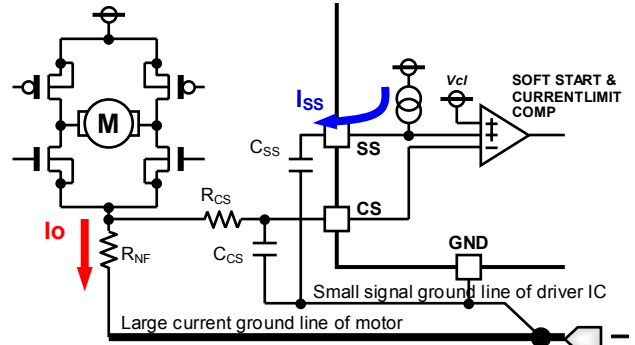

Figure 39. Setting of current limit and ground line

3) Soft start

Soft start is a function to gradually raise a driving torque at the time of motor start. Be effective against reducing undesired sound and inrush current.

The soft start time is set by the charge to the capacitor connected with the terminal SS.

If motor output current (I_o) and SS time (T_{SS}) are decided, the value of capacitor (C_{SS}) that sets a soft start can be calculated by the following expressions because SS charge current (I_{SS}) is 120nA.

$$C_{SS}[F] = (I_{SS}[A] \times T_{SS}[s]) / (I_o[A] \times R_{NF}[\Omega])$$

(ex.) When assuming that $T_{SS} = 0.47[s]$, $I_o = 1.2[A]$, and $R_{NF} = 0.1[\Omega]$,

$$C_{SS}[F] = (120[nA] \times 0.47[s]) / (1.2[A] \times 0.1[\Omega])$$

$$= 0.47 \times 10^{-6}[F]$$

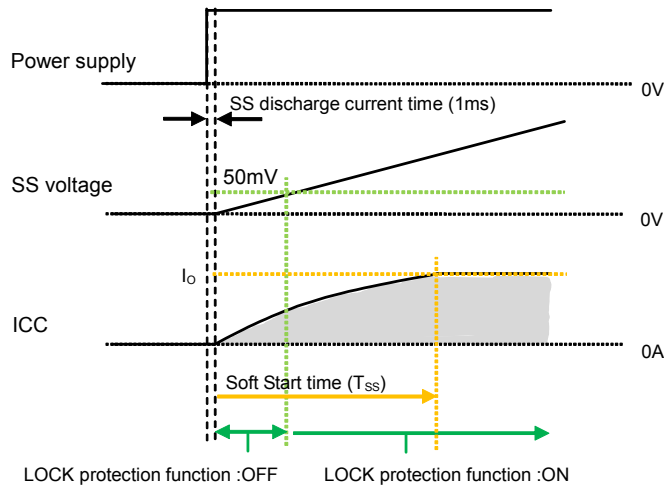

Figure 40. Output current characteristics by the soft start function

When Soft start time is set for a long time, lock protection may be detected without enough motor torque. Therefore, a lock protection function is turned off until SS voltage becomes 50mV (Typ). If it is not used the soft start function, open the SS terminal.

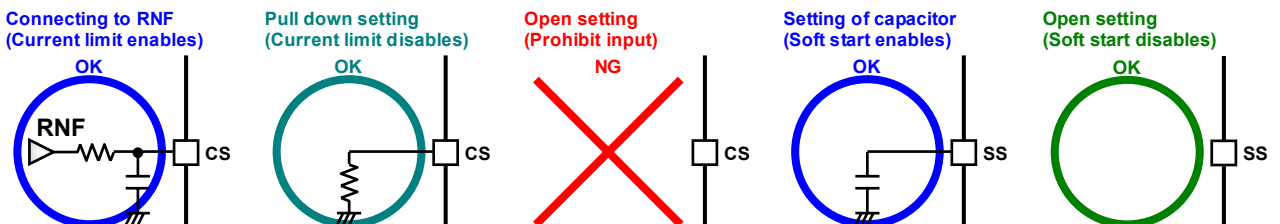

Figure 41. Setting of the current limit and the soft start functions

4) Quick start

When torque off logic is input by the control signal over fixed time (1.0ms), the lock protection function disables. And the motor could restart quickly at the timing of control signal is input. The lock protection function doesn't work in an input frequency that is slower than 1kHz when assuming high level duty = 100% of the MIN input signal. Input signal frequency is faster than 2kHz.

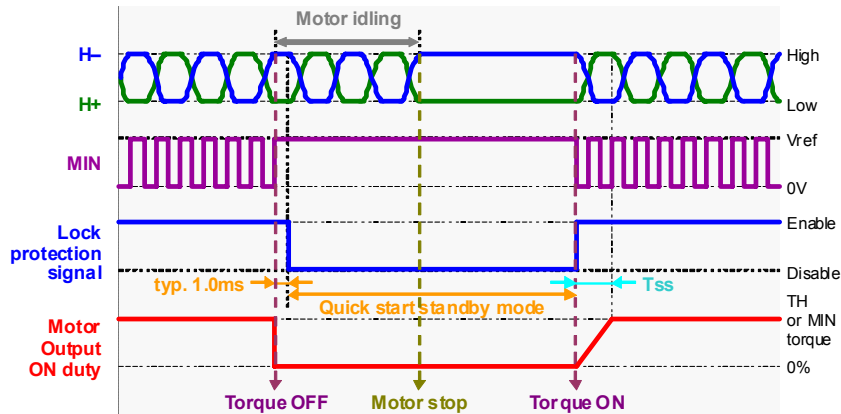

Figure 42. PWM input and quick start timing chart

5) Hall input setting

Hall input voltage range is shown in operating conditions (P.2).

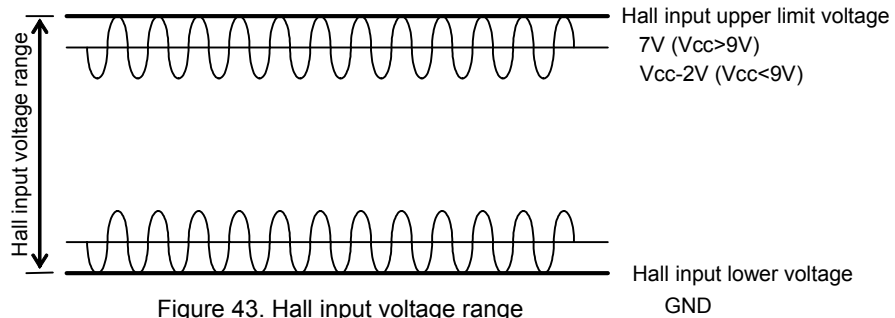

Figure 43. Hall input voltage range

Adjust the value of hall element bias resistor R1 in Figure 44 so that the input voltage of a hall amplifier is input in "Hall Input Voltage" including signal amplitude. In order to detect rotation of a motor, the amplitude of hall signal more than "Hall Input Hysteresis Voltage" is required. In consideration of PWM soft switching to mention later, input hall signal more than ±100mV at least.

Reducing the noise of hall signal

Vcc noise or the like depending on the wiring pattern of board may affect Hall element. In this case, place a capacitor like C1 in Figure 44. In addition, when wiring from the hall element output to IC hall input is long, noise may be loaded on wiring. In this case, place a capacitor like C2 in Figure 44.

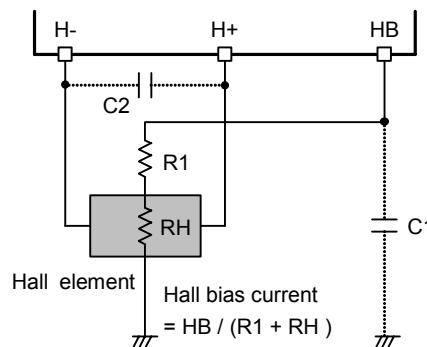

Figure 44. Application near hall signal

6) PWM soft switching

The PWM soft switching section is set to the timing before and after the change of the hall signal. Be effective against reducing undesired sound. Adjusting the amplitude of the hall signal can change the length of the PWM soft switching section. The PWM soft switching section becomes wide if the amplitude of the hall signal is reduced, and the gradient of the output current becomes smooth. However, when a soft switching is applied too much, torque shortage might be caused. Input hall signal more than $\pm 100\text{mV}$ at least.

The PWM soft switching function operates in the DC input application and the pulse input application.

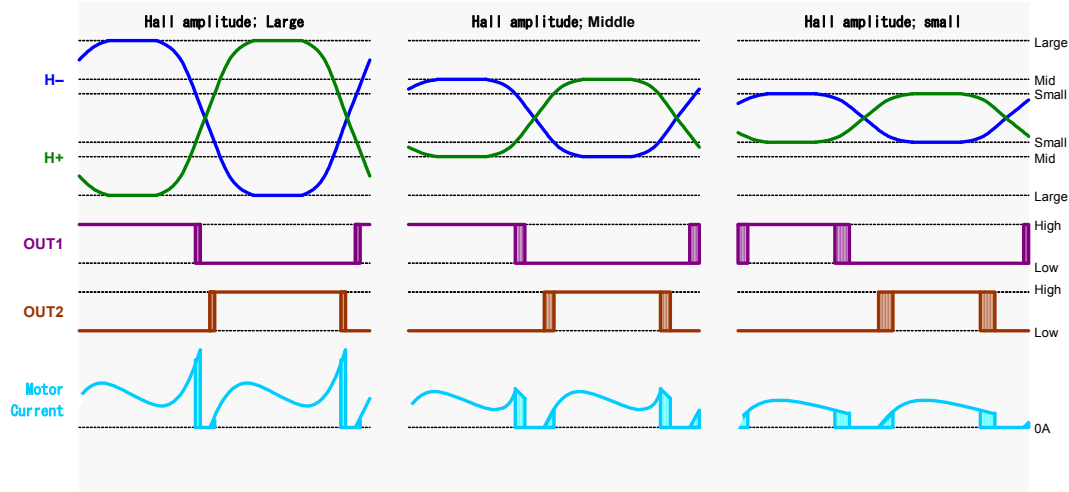

Figure 45. Relation between hall signal amplitude and output wave

7) Lock protection and automatic restart

Motor rotation is detected by hall signal period. IC detects motor rotation is stop when the period becomes longer than the time set up at the internal counter, and IC turns off the output. Lock detection ON time (t_{ON}) and lock detection OFF time (t_{OFF}) are set by the digital counter based on internal oscillator. Therefore the ratio of ON/OFF time is always constant. Timing chart is shown in Figure 46.

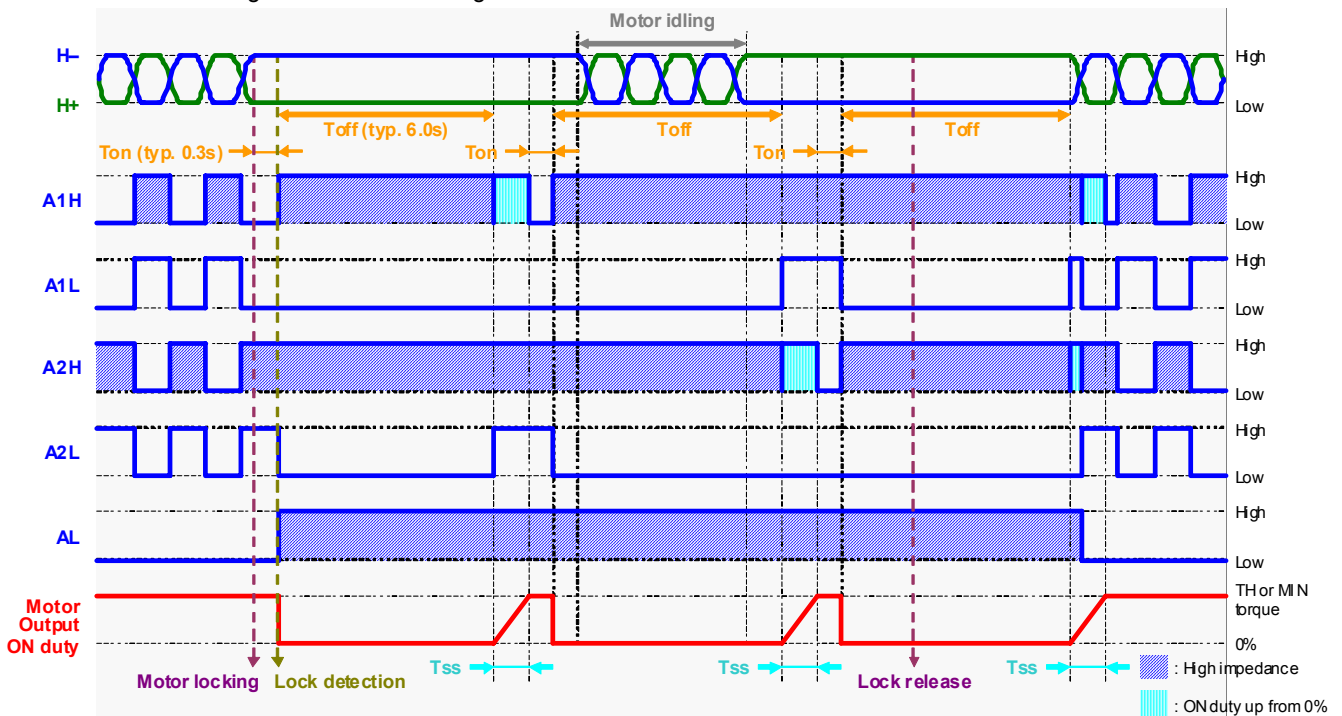

Figure 46. Lock protection (incorporated counter system) timing chart

8) The upper side output of pre driver

The upper side output of pre driver is constant current open-drain. In Figure 47, decide the resistance of R1 so that the voltage generated between gate and source of external PMOS transistor may exceed enough the threshold voltage of the transistor.

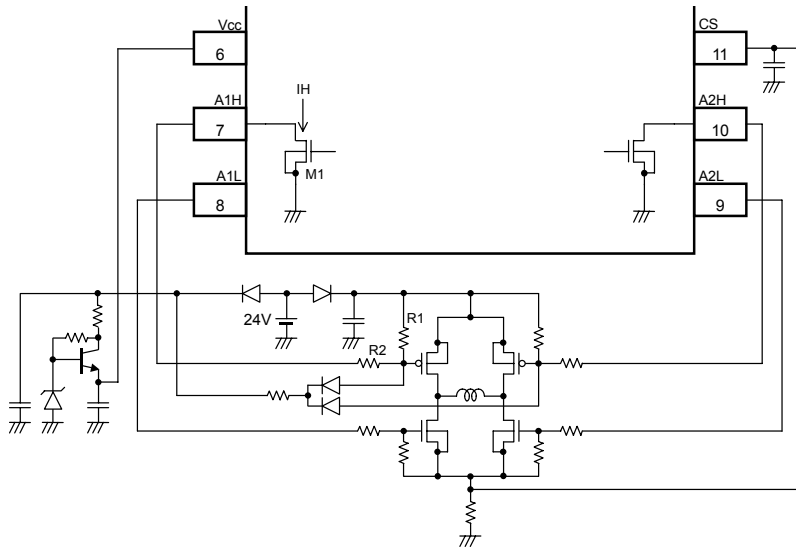

Figure 47. 24V application

(ex.) At R1=1kΩ, PMOS transistor gate-source voltage V_{GSP} can be shown below,

$$\begin{aligned}
 V_{GSP} &= R1 \times I_H \\
 &= 1k\Omega \times 12mA \text{ (Typ)} \\
 &= 12V
 \end{aligned}$$

R2 is used to suppress the power consumption of IC.

At power supply = 24V, the power consumption P_{M1} of upside output transistor M1 is

$$\begin{aligned}
 P_{M1} &= \{ VM - (R1 + R2) \times I_H \} \times I_H \\
 &= 144mW \text{ (at } R1 = 1k\Omega, R2 = 0\Omega) \\
 &= 72mW \text{ (at } R1 = 1k\Omega, R2 = 0.5k\Omega)
 \end{aligned}$$

Useless power consumption in the upside output is suppressed by appropriately setting R2, and a permissible loss of the package can be used effectively in lower output.

High voltage application

It is possible to correspond to 24V and 48V power supply by using the application circuit that is set not to exceed the absolute maximum rating of Vcc, A1H to A2L, and AL terminal.

Refer to the application circuit of P14 and P15.

Absolute maximum rating voltage of pre driver

Power supply	Lower output	Upper output	AL output
20V	15V (CMOS output)	36V (Open drain output)	20V (Open drain output)

Equivalent circuit

1) Hall input terminal

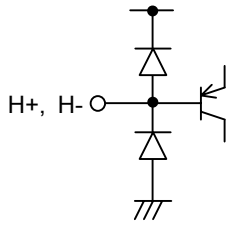

2) High side output 1,2 pins Low side output 1,2 pins

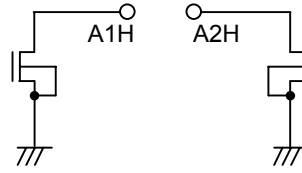

3) Output current detecting terminal

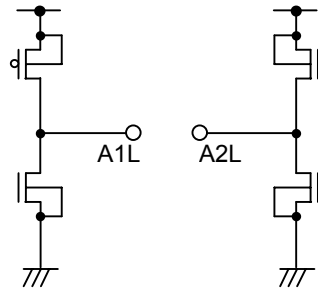
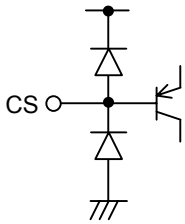

4) Reference voltage terminal

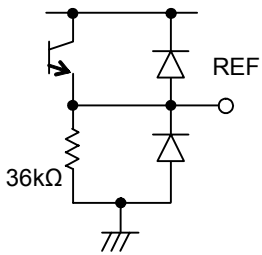

5) Hall bias terminal

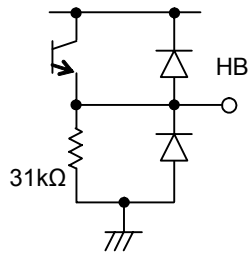

6) AL output terminal

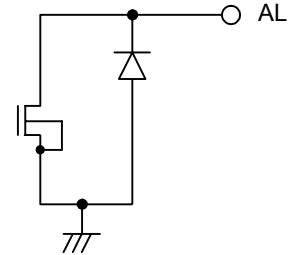

7) Variable amplifier input terminal

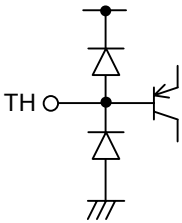

8) Minimum rotating speed setting terminal

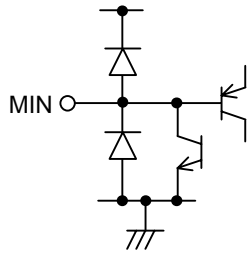

9) Oscillating capacitor connecting terminal

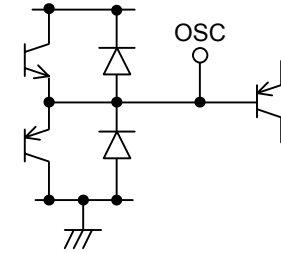

10) Soft start capacitor-connecting terminal

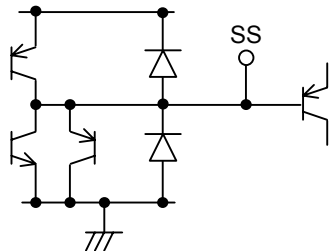

Safety Measure

1) Reverse Connection Protection Diode

Reverse connection of power results in IC destruction as shown in Figure 48. When reverse connection is possible, reverse connection protection diode must be added between power supply and VCC.

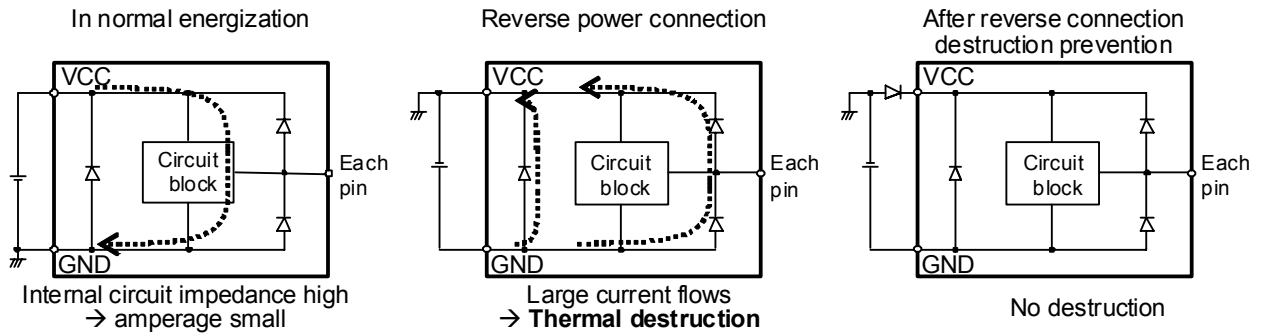

Figure 48. Flow of Current when Power is Connected Reversely

2) Protection against VCC Voltage Rise by Back Electromotive Force

Back EMF generates regenerative current to power supply. However, when reverse connection protection diode is connected, VCC voltage rises because the diode prevents current flow to power supply.

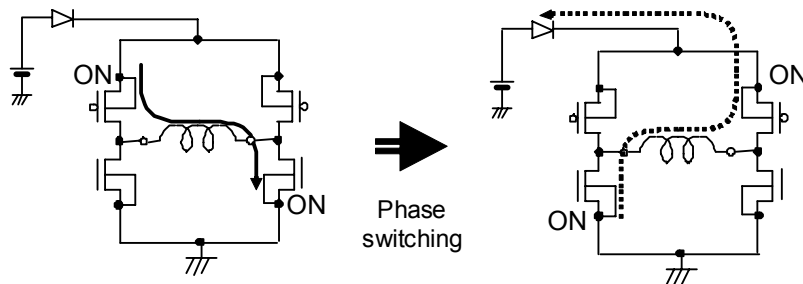

Figure 49. VCC Voltage Rise by Back Electromotive Force

When the absolute maximum rated voltage may be exceeded due to voltage rise by back electromotive force, place (A) Capacitor or (B) Zener diode between VCC and GND. It necessary, add both (C).

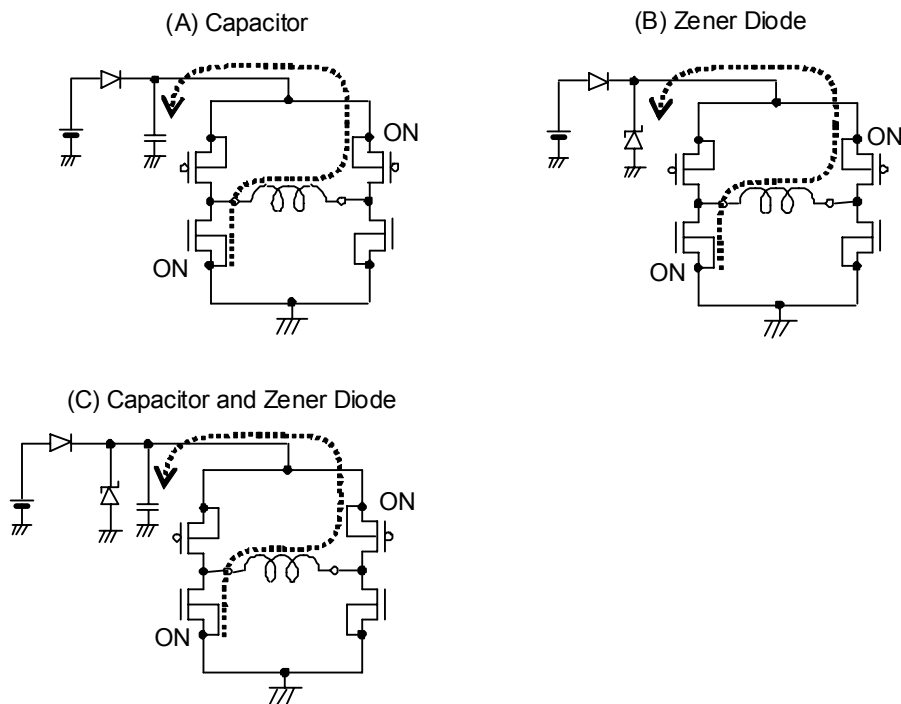

Figure 50. Protection against VCC Voltage Rise

3) Problem of GND Line PWM Switching

Do not perform PWM switching of GND line because GND potential cannot be kept to a minimum.

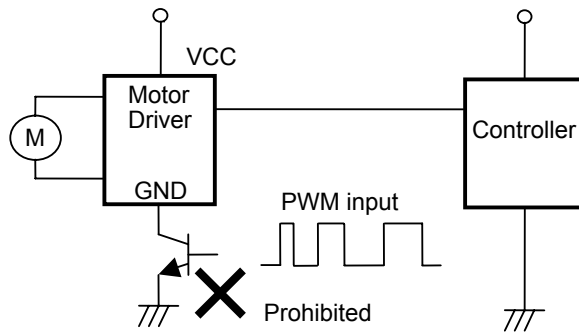

Figure 51. GND Line PWM Switching Prohibited

4) AL Output

AL is an open drain output and requires pull-up resistor. VCC voltage that is beyond its absolute maximum rating when AL pin is directly connected to power supply, could damage the IC. The IC can be protected by adding resistor R1. (as shown in Figure 52)

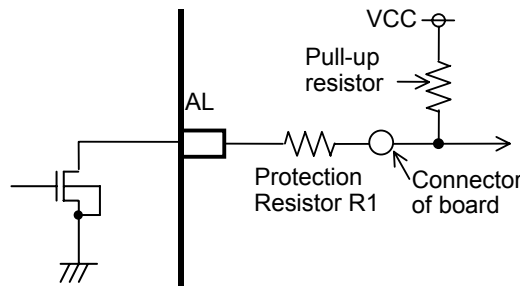
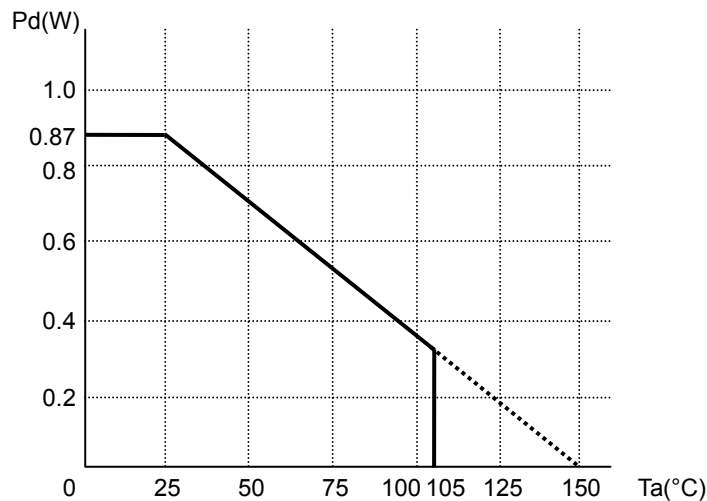

Figure 52. Protection of AL Pin

Thermal Derating Curve

Thermal derating curve indicates power that can be consumed by IC with reference to ambient temperature. Power that can be consumed by IC begins to attenuate at certain ambient temperature. This gradient is determined by thermal resistance θ_{ja} .

Thermal resistance θ_{ja} depends on chip size, power consumption, package ambient temperature, packaging condition, wind velocity, etc., even when the same package is used. Thermal derating curve indicates a reference value measured at a specified condition. Figure 53 shows a thermal derating curve.



Reduce by 7.0 mW/°C over 25°C.
(70.0mm x 70.0mm x 1.6mm glass epoxy board)

Figure 53. Thermal Derating Curve

Operational Notes

1. Reverse Connection of Power Supply

Connecting the power supply in reverse polarity can damage the IC. Take precautions against reverse polarity when connecting the power supply, such as mounting an external diode between the power supply and the IC's power supply pins.

2. Power Supply Lines

Design the PCB layout pattern to provide low impedance supply lines. Separate the ground and supply lines of the digital and analog blocks to prevent noise in the ground and supply lines of the digital block from affecting the analog block. Furthermore, connect a capacitor to ground at all power supply pins. Consider the effect of temperature and aging on the capacitance value when using electrolytic capacitors.

3. Ground Voltage

Ensure that no pins are at a voltage below that of the ground pin at any time, even during transient condition. However, pins that drive inductive loads (e.g. motor driver outputs, DC-DC converter outputs) may inevitably go below ground due to back EMF or electromotive force. In such cases, the user should make sure that such voltages going below ground will not cause the IC and the system to malfunction by examining carefully all relevant factors and conditions such as motor characteristics, supply voltage, operating frequency and PCB wiring to name a few.

4. Ground Wiring Pattern

When using both small-signal and large-current ground traces, the two ground traces should be routed separately but connected to a single ground at the reference point of the application board to avoid fluctuations in the small-signal ground caused by large currents. Also ensure that the ground traces of external components do not cause variations on the ground voltage. The ground lines must be as short and thick as possible to reduce line impedance.

5. Thermal Consideration

Should by any chance the power dissipation rating be exceeded the rise in temperature of the chip may result in deterioration of the properties of the chip. The absolute maximum rating of the Pd stated in this specification is when the IC is mounted on a 70mm x 70mm x 1.6mm glass epoxy board. In case of exceeding this absolute maximum rating, increase the board size and copper area to prevent exceeding the Pd rating.

6. Recommended Operating Conditions

These conditions represent a range within which the expected characteristics of the IC can be approximately obtained. The electrical characteristics are guaranteed under the conditions of each parameter.

7. Inrush Current

When power is first supplied to the IC, it is possible that the internal logic may be unstable and inrush current may flow instantaneously due to the internal powering sequence and delays, especially if the IC has more than one power supply. Therefore, give special consideration to power coupling capacitance, power wiring, width of ground wiring, and routing of connections.

8. Operation Under Strong Electromagnetic Field

Operating the IC in the presence of a strong electromagnetic field may cause the IC to malfunction.

9. Testing on Application Boards

When testing the IC on an application board, connecting a capacitor directly to a low-impedance output pin may subject the IC to stress. Always discharge capacitors completely after each process or step. The IC's power supply should always be turned off completely before connecting or removing it from the test setup during the inspection process. To prevent damage from static discharge, ground the IC during assembly and use similar precautions during transport and storage.

10. Inter-pin Short and Mounting Errors

Ensure that the direction and position are correct when mounting the IC on the PCB. Incorrect mounting may result in damaging the IC. Avoid nearby pins being shorted to each other especially to ground, power supply and output pin. Inter-pin shorts could be due to many reasons such as metal particles, water droplets (in very humid environment) and unintentional solder bridge deposited in between pins during assembly to name a few.