



Chipsmall Limited consists of a professional team with an average of over 10 year of expertise in the distribution of electronic components. Based in Hongkong, we have already established firm and mutual-benefit business relationships with customers from,Europe,America and south Asia,supplying obsolete and hard-to-find components to meet their specific needs.

With the principle of “Quality Parts,Customers Priority,Honest Operation,and Considerate Service”,our business mainly focus on the distribution of electronic components. Line cards we deal with include Microchip,ALPS,ROHM,Xilinx,Pulse,ON,Everlight and Freescale. Main products comprise IC,Modules,Potentiometer,IC Socket,Relay,Connector.Our parts cover such applications as commercial,industrial, and automotives areas.

We are looking forward to setting up business relationship with you and hope to provide you with the best service and solution. Let us make a better world for our industry!



Contact us

Tel: +86-755-8981 8866 Fax: +86-755-8427 6832

Email & Skype: info@chipsmall.com Web: www.chipsmall.com

Address: A1208, Overseas Decoration Building, #122 Zhenhua RD., Futian, Shenzhen, China



DC/DC Driver

Power Factor Correction Controller IC

BD7690FJ

General Description

BD7690FJ is Power Factor Correction for AC/DC supplies the system which is suitable for all the products needing power factor improvement. The PFC adopts boundary conduction mode (BCM), and switching loss reduction and noise reduction are possible by Zero Current Detection (ZCD). ZCD is detected by auxiliary winding.

Key Specifications

- Input Voltage Range: 10V to 26V
- Operating Current: 310uA(Typ)
- Max Frequency: 220kHz(RT:220kΩ)
- Operating Temperature Range: -40°C to +105°C

Package(s)
SOP-J8

W(Typ) x D(Typ) x H(Max)
4.90mm x 6.00mm x 1.65mm

Features

- Boundary Conduction Mode
- Low Power consumption
- VCCUVLO
- The ZCD detection by auxiliary winding
- Switching loss reduction, noise reduction by ZCD
- Improving the efficiency by the max frequency control
- Dynamic and Static OVP by the VS pin
- High accuracy over current detection(±4%)
- Error amplifier input short protection
- Restart timer
- Stable MOSFET gate drive by the Clamper



SOP-J8

Applications

- AC adaptor, TV, Lighting equipment, Refrigerator, etc.

Typical Application Circuit(s)

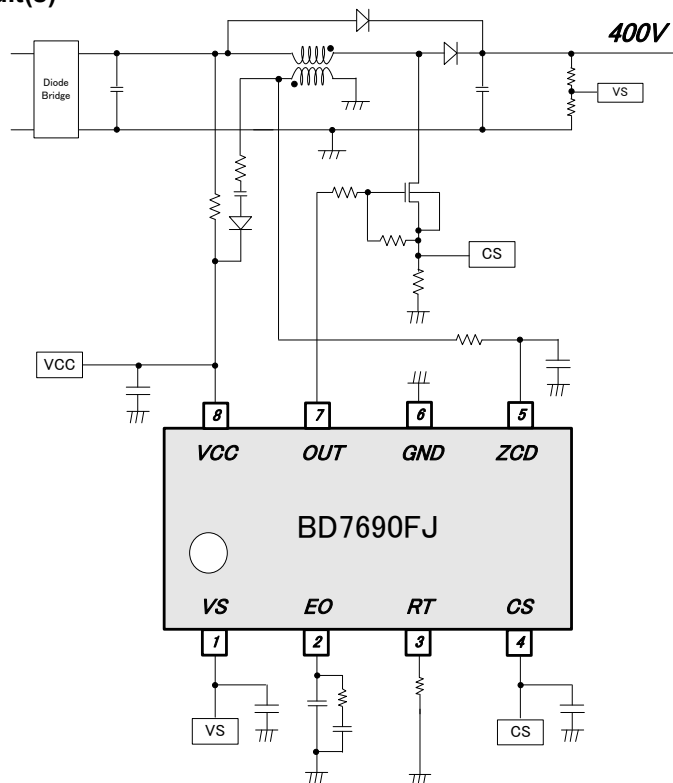

Figure 1. Application Circuit

○Product structure : Silicon monolithic integrated circuit ○This product has no designed protection against radioactive rays

Contents

General Description.....	1
Contents	2
Pin Configuration(s)	3
Pin Description(s)	3
Block Diagram(s)	3
Description of Block(s).....	4
Operation mode of the protective circuit.....	9
Absolute Maximum Ratings (Ta = 25°C)	10
Thermal Resistance ^(Note 1)	10
Recommended Operating Conditions (Ta=25°C)	10
Electrical Characteristics (Unless otherwise specified VCC=15V Ta=25°C).....	11
I/O Equivalence Circuits	14
Application Example.....	14
Attention in the board design	16
About parts placement	16
Operational Notes	18
Ordering Information	20
Marking Diagrams	20
Physical Dimension, Tape and Reel Information	21
Revision History	22

Pin Configuration(s)

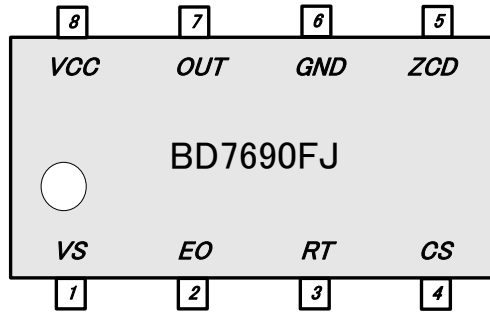

Figure 2. Pin Configuration (Top View)

Pin Description(s)

Table 1. Pin Description

Pin Name	I/O	Pin No.	Function	ESD Diode	
				VCC	GND
VS	I	1	Feedback input	-	○
EO	I/O	2	Error amp output	-	○
RT	I/O	3	Max frequency setting	-	○
CS	I	4	Over current detection	-	○
ZCD	I	5	Zero current detection	-	○
GND	-	6	GND	○	-
OUT	O	7	MOSFET gate control	-	○
VCC	I	8	VCC	-	○

Block Diagram(s)

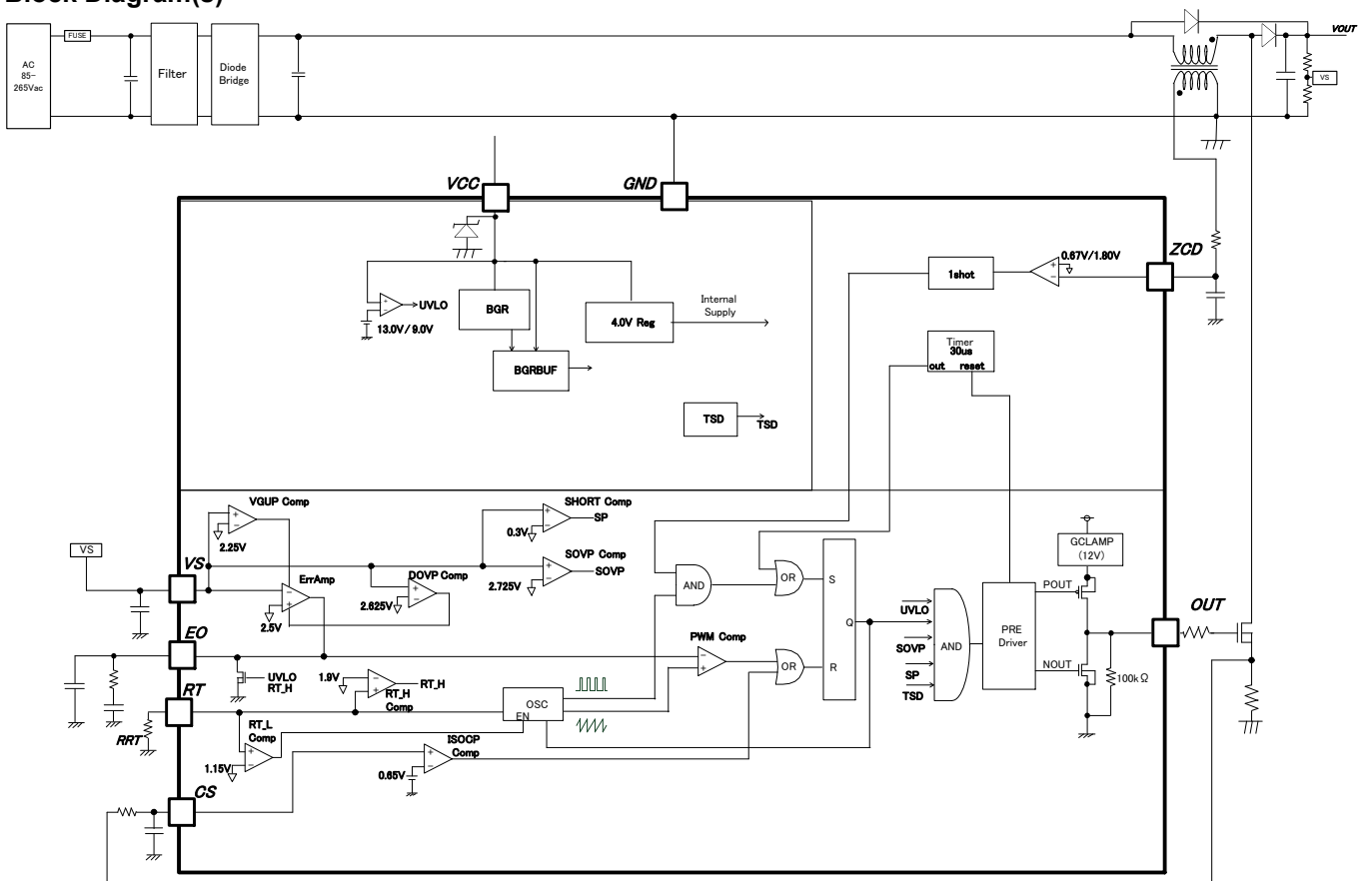

Figure 3. Block Diagram

Description of Block(s)

(1) VCC protection

This IC incorporates VCC UVLO (Under Voltage Lock Out) of the VCC pin. Switching stops at the time of VCC voltage drop.

(2) Power Factor Correction

The power factor improvement circuit is a voltage control method of Boundary Conduction Mode. The outline operation circuit diagram is shown in Figure 4. The switching operation is shown in Figure 5.

Switching Operation

1. MOSFET is turned on, and I_L increases
2. The IC compares V_{EO} with V_{ramp} , and MOSFET is off when the V_{ramp} voltage higher than V_{EO}
3. MOSFET is off, and I_L decreases
4. The IC detects a zero point of the I_L in ZCD and turns on MOSFET

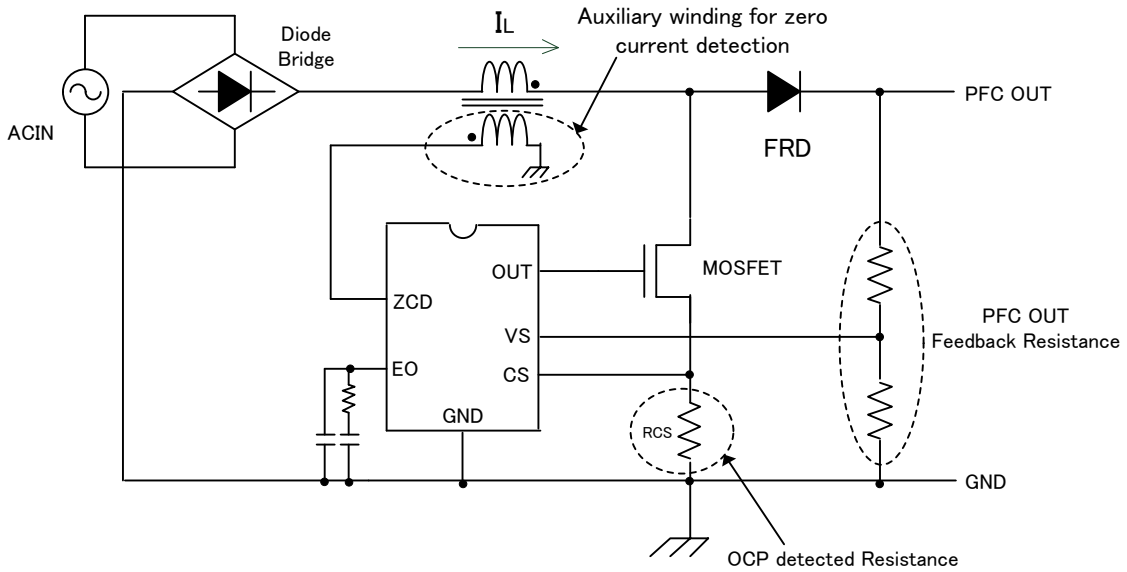

Figure 4. Operation circuit outline

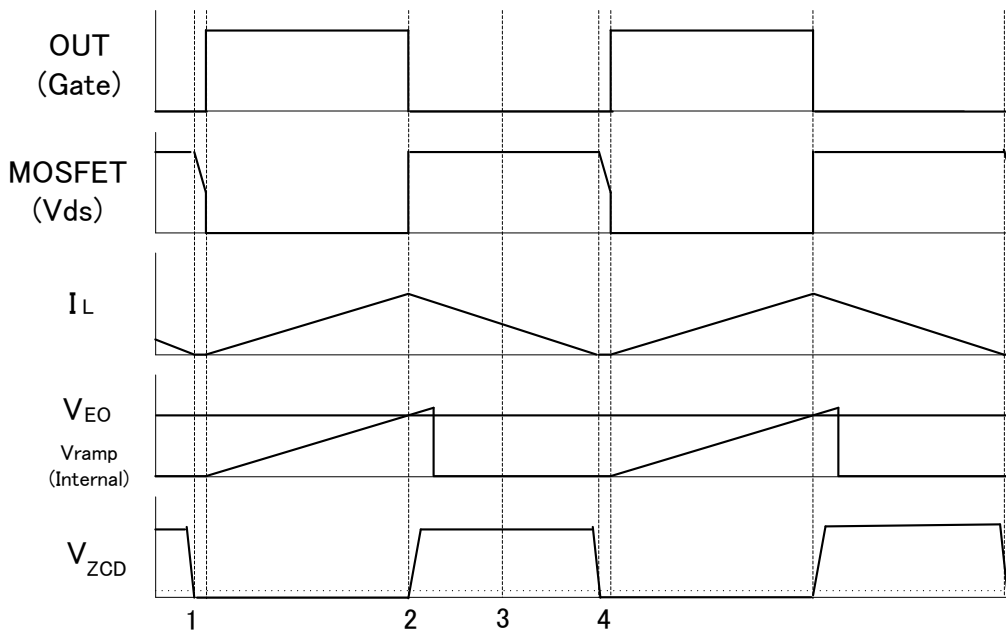

Figure 5. Switching operation timing chart

(3) About ErrAMP

(3-1) gmAMP

The VS pin monitors a divided voltage of the output voltage. The ripple voltage of AC frequency (50Hz/60Hz) overlaps with VS pin. gmAMP removes this ripple voltage. gmAMP compares VAMP (2.5V typ.) with the divided voltage of the output voltage, gmAMP controls the EO voltage by this gap. When EO pin voltage rises, ON width of the OUT pin becomes wide. When the EO voltage less than about 0.7V, the IC stops switching. Therefore it can stop switching operation when EO pin connects to the GND.

External parts value of EO pin should be set that the ripple voltage of AC frequency does not conduct to EO pin. And, please confirm it by real board.

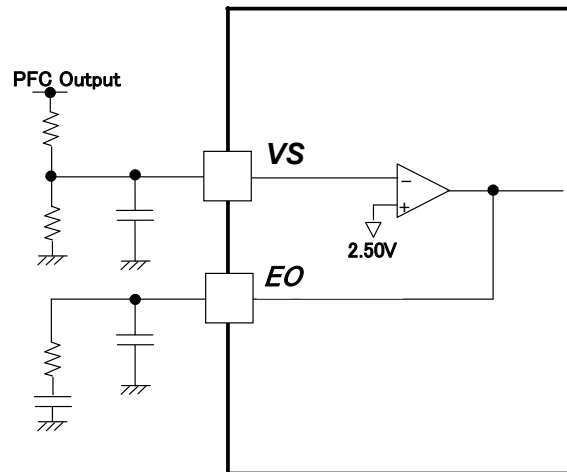

Figure 6. gmAMP block diagram

(3-2) VS short protection

VS pin has a short protection function.

A state of PFC output voltage $< V_{SHORT}$ (0.3V typ.) continues more than T_{VS_SH} (150us typ.), it stops switching. It shows operation in Figure 7.

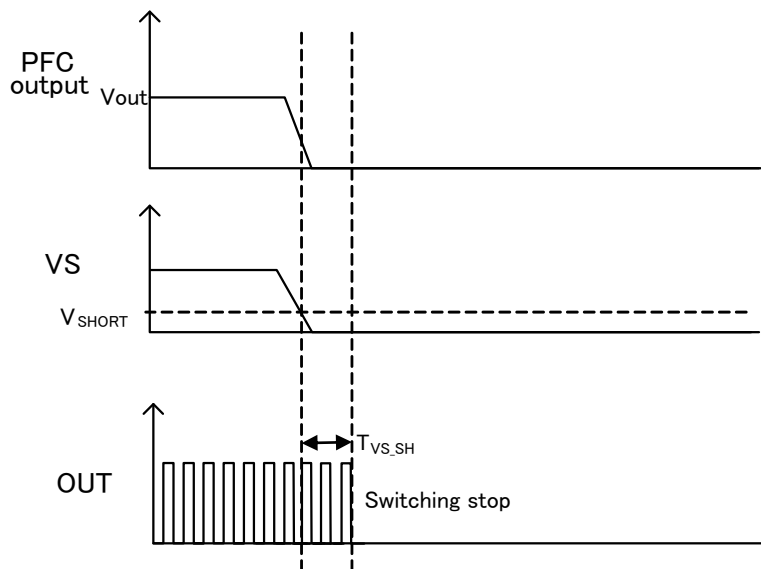

Figure 7. Operation of VS short protection

(3-3) VS low voltage gain increase function

When output voltage decreases by output load sudden changes, an output voltage drop period becomes long because a voltage control loop is slow. VS pin voltage becomes lower than V_{GUP} (2.25V typ.) (equivalent to -10% of output voltage), the error amplifier increases a gain. By this operation, ON width of OUT increases and prevents a long-term drop of the output voltage. When VS pin voltage rises from V_{GUP} (2.25V typ.), this operation stops.

(3-4) VS overvoltage gain increase function (Dynamic OVP)

When output voltage rises by startup or a rapid change of the output load, output voltage rises for a long term because a voltage control loop is slow. VS pin voltage becomes higher than V_{OVP} (2.625V typ.) (equivalent to +5% of output voltage), the error amplifier increases a gain. By this operation, it reduces ON width of OUT and prevents a long-term rise of the output voltage. When VS pin voltage decreases under V_{OVP} (2.625V typ.), this operation stops.

(3-5) VS overvoltage protection function (Static OVP)

VS pin rises across V_{OVP} , static OVP acts, and VS pin voltage rises from V_{OVP1} (2.7V typ.), it stops switching immediately. VS pin voltage under than V_{OVP2} (2.6V typ.), it starts switching. It shows operation in Figure 8.

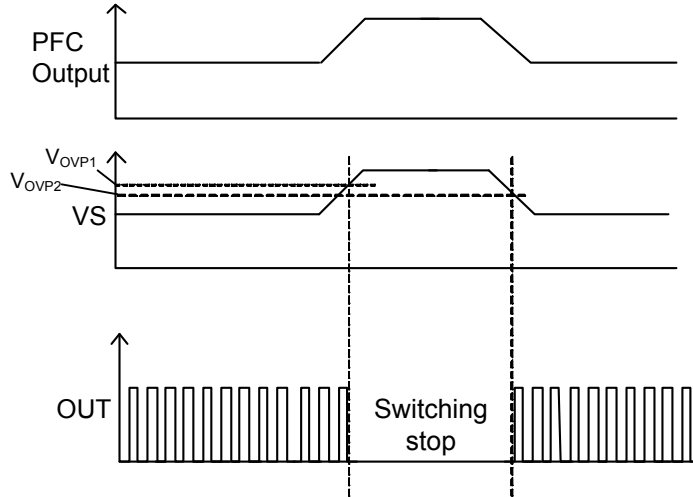

Figure 8. VS overvoltage protection operation

(4) CS overcurrent detection

In operation, turn OFF of PFC is usually decided in EO pin voltage. However, when CS pin rises than overcurrent detection voltage (the CS pin threshold voltage) V_{cs} (0.65V typ.), overcurrent protection works. For this protection, OUT pin turn off pulse by pulse.

The overcurrent protection limits ON width. The PFC voltage is decrease when this OCP works. Please decide RCS value of PFC so that this protection does not work in rated load with the minimum input voltage at the time of the application design.

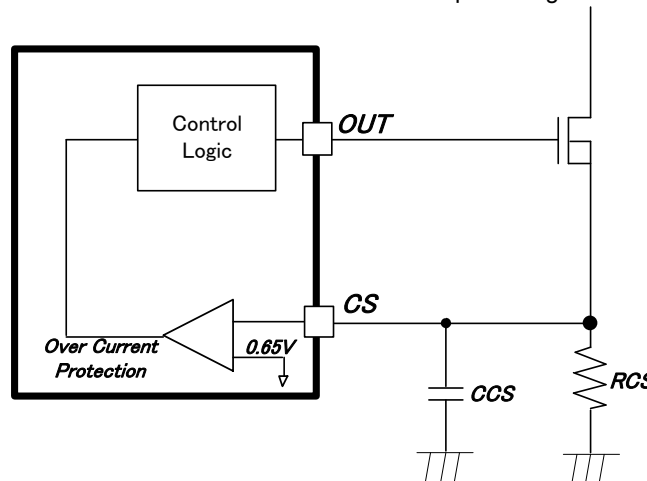

Figure 9. CS overcurrent detection

(5) ZCD pin zero current detection

The zero current detection circuit is a function to detect a zero cross of the inductor current (I_L) (cf. Figure 10). In addition, it recommends that it adds CR filter for switching noise reduction. It inserts R1 for limit the current between auxiliary winding and ZCD pin to use ZCD pin in rating. In addition, V_{ds} of Q1 performs free resonance when inductor current disappears. It can suppress a switching loss and the surge of Q1 by coordinating R1,C1 so that Q1 is turned on in the valley of the resonance wave pattern.

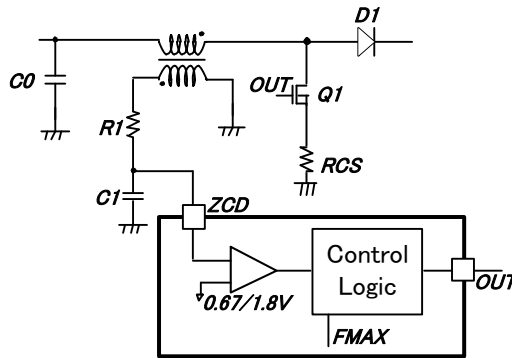

Figure 10. ZCD circuit

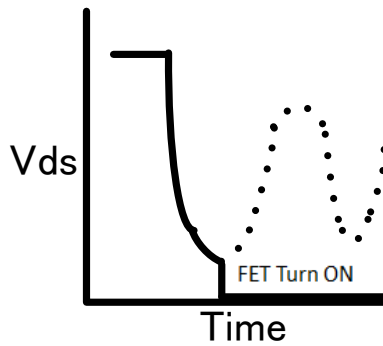

Figure 11. Drain wave patterns

(6) RT pin

This pin sets a slope wave pattern formed in the IC inside by external resistance. It shows RT resistor value and relations of the maximum frequency in Figure 12. The maximum ON width on the application is calculated in the following formula. It shows relations of RT resistor value and maximum ON width in Figure 13.

$$T_{ON_MAX}[s] = \frac{2 \times L \times P_o}{V_{ACMin}^2 \times \eta}$$

V_{ac}: Input voltage, L: Inductance, P_o: Max output power, η:Efficiency

Necessary TON_MAX on application can be check as upper formula. Please set ON width in RT pin more than TONMAX. In addition, the high-speed frequency in the light load is limited in RT pin. The external resistance range of the RT pin is 51kΩ - 390kΩ.

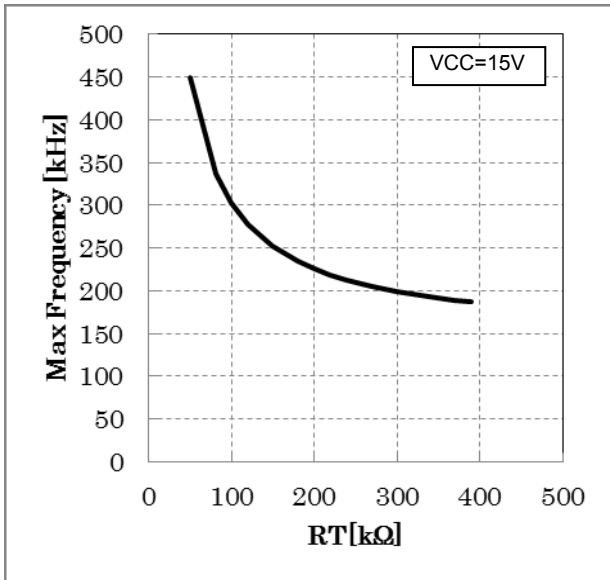

Figure 12. Relations of RT resistor value and the Max frequency (reference value)

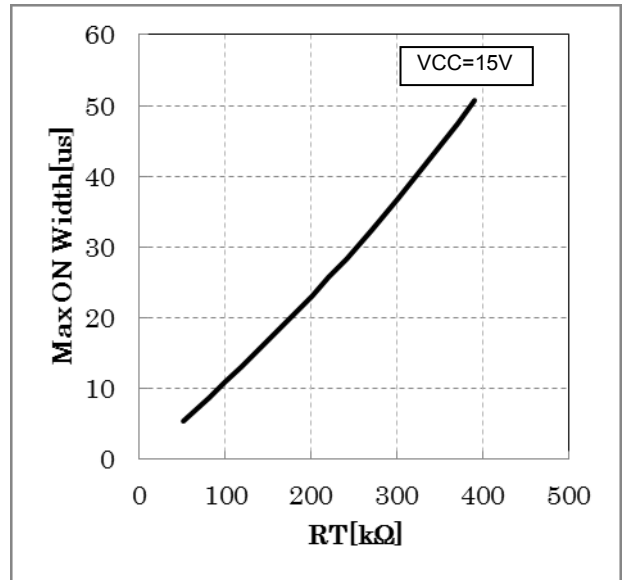

Figure 13. Relations of RT resistor value and the Max ON width (reference value)

*The graph mentioned above is reference value. After the confirmation of the actual board, please set the fixed number.

Operation mode of the protective circuit

It shows the operation mode of each protection function in Table 2.

Table 2. Operation mode of each protective circuit

Parameter	Contents	Protection mode			
		Detection method	Detect operation	Cancellation method	Cancellation operation
VCCUVLO	VCC pin low voltage protection	$VCC < 9.0V(\text{typ.})$ (VCC drop)	OUT stop EO discharge	$VCC > 13.0V(\text{typ.})$ (VCC rise)	Startup operation
VS short protection	VS pin short protection	$VS < 0.30V(\text{typ.})$ (VS drop)	OUT stop	$VS > 0.30V(\text{typ.})$ (VS rise)	Normal operation
VS gain increase	VS pin low voltage gain increase	$VS < 2.25V(\text{typ.})$ (VS drop)	GM amplifier GAIN increase	$VS > 2.25V(\text{typ.})$ (VS rise)	Normal operation
VS Dynamic OVP	VS pin overvoltage protection 1	$VS > 2.625V(\text{typ.})$ (VS rise)	GM amplifier GAIN increase	$VS < 2.625V(\text{typ.})$ (VS drop)	Normal operation
VS Static OVP	VS pin overvoltage protection 2	$VS > 2.700V(\text{typ.})$ (VS rise)	OUT stop	$VS < 2.600V(\text{typ.})$ (VS drop)	Normal operation

Absolute Maximum Ratings (Ta = 25°C)

Parameter	Symbol	Rating	Unit	Condition
Max Voltage 1	V _{max1}	-0.3 to +28.0	V	VCC
Max Voltage 2	V _{max2}	-0.3 to +15.0	V	OUT
Max Voltage 3	V _{max3}	-0.3 to +6.5	V	CS, RT, VS, EO
Max Current 1	I _{zcd1}	-10.0 to +10.0	mA	ZCD
OUT pin output peak current 1	I _{OUT1}	-0.5	A	Source current
OUT pin output peak current 2	I _{OUT2}	+1.0	A	Sink current
Operation Temperature Range	T _{opr}	-40 to +105	°C	
Storage Temperature Range	T _{str}	-55 to +150	°C	

Caution: Operating the IC over the absolute maximum ratings may damage the IC. The damage can either be a short circuit between pins or an open circuit between pins and the internal circuitry. Therefore, it is important to consider circuit protection measures, such as adding a fuse, in case the IC is operated over the absolute maximum ratings.

Thermal Resistance (Note 1)

Parameter	Symbol	Thermal Resistance (Typ)		Unit
		1s ^(Note 3)	2s2p ^(Note 4)	
SOP-J8				
Junction to Ambient	θ_{JA}	149.3	76.9	°C/W
Junction to Top Characterization Parameter ^(Note 2)	Ψ_{JT}	18	11	°C/W

(Note 1)Based on JESD51-2A(Still-Air)

(Note 2)The thermal characterization parameter to report the difference between junction temperature and the temperature at the top center of the outside surface of the component package.

(Note 3)Using a PCB board based on JESD51-3.

(Note 4)Using a PCB board based on JESD51-7.

Layer Number of Measurement Board	Material	Board Size
Single	FR-4	114.3mm x 76.2mm x 1.57mmt
Top		
Copper Pattern	Thickness	
Footprints and Traces	70μm	

Layer Number of Measurement Board	Material	Board Size			
4 Layers	FR-4	114.3mm x 76.2mm x 1.6mmt			
Top		2 Internal Layers		Bottom	
Copper Pattern	Thickness	Copper Pattern	Thickness	Copper Pattern	Thickness
Footprints and Traces	70μm	74.2mm x 74.2mm	35μm	74.2mm x 74.2mm	70μm

Recommended Operating Conditions (Ta=25°C)

Parameter	Symbol	Rating	Unit	Condition
Supply Voltage	V _{CC}	10.0~26.0	V	VCC voltage

Recommended range of the external component (Ta=25°C)

Parameter	Symbol	Range	Unit
VCC pin connection capacity	C _{VCC}	More than 10.0	uF
RT pin connection resistance	R _{RT}	51 to 390	kΩ

Electrical Characteristics (Unless otherwise specified VCC=15V Ta=25°C)

Parameter	Symbol	Specifications			Unit	Condition
		Min	Typ	Max		
[Circuit Current]						
Circuit Current(ON)1	I _{ON1}	-	310	600	uA	EO=0.0V, RT=220kΩ
Circuit Current (ON)2	I _{ON2}	-	380	700	uA	EO=3.0V, RT=220kΩ (Switching operation)
Start Up Current	I _{ON3}	-	65	130	uA	VCC=12V
[VCC pin protection]						
VCC UVLO Voltage1	V _{UVLO1}	12.0	13.0	14.0	V	VCC rise
VCC UVLO Voltage2	V _{UVLO2}	8.0	9.0	10.0	V	VCC drop
VCC UVLO Hysteresis	V _{UVLO3}	-	4.0	-	V	V _{UVLO3} = V _{UVLO1} - V _{UVLO2}
[Gm Amplifier Block]						
VS pin Pull Up Current	I _{VS}	-	0.5	-	uA	
Gm Amplifier Reference Voltage 1	V _{AMP}	2.465	2.500	2.535	V	
Gm Amplifier Line Regulation	V _{AMP_line}	-20	-1	-	mV	VCC10V to 26V
Gm Amplifier Trans Conductance	T _{VS}	50	75	100	uA/V	EO=2.5V V _{GUP} < VS < V _{OVP}
Gm Amplifier Source Current	I _{EO_source}	30	50	70	uA	VS=1.0V
Gm Amplifier Sink Current	I _{EO_sink}	30	50	70	uA	VS=3.5V
[EO Block]						
OFF Threshold Voltage	EO _{OFF_TH}	0.57	0.67	0.77	V	
EO Discharge Resistance	R _{EO}	2.3	4.3	6.3	kΩ	VCC=12V, EO=3V
[OSC Block]						
MAX ON Width	T _{MAXDUTY}	23.4	26.0	28.6	us	RT=220kΩ EO=4V
MAX Frequency	F _{MAXDUTY}	160	220	280	kHz	RT=220kΩ EO=0.7V
RT Output Voltage	V _{RT}	0.90	1.15	1.40	V	
[ZCD Block]						
ZCD Threshold Voltage 1	V _{zcd1}	1.65	1.80	1.95	V	ZCD rise
ZCD Threshold Voltage 2	V _{zcd2}	0.55	0.67	0.79	V	ZCD drop
Minimum Detection Pulse Width	T _{zcd1}	100	200	-	ns	
ZCD Output Delay	T _{zcd2}	-	260	520	ns	
Input Clamp Voltage (High)	V _{ih}	6.1	6.7	7.3	V	I _{sink} =3mA
Input Clamp Voltage (Low)	V _{il}	-0.3	-0.1	-	V	I _{source} =-3mA
[Restart Block]						
Restart Time	T _{RS}	15.0	30.0	45.0	us	ZCD=0V VS=EO=2.5V
[VS Protection Block]						
VS Short Protection Detection Voltage	V _{SHORT}	0.200	0.300	0.400	V	
VS Shortstop Protection Detection Time	T _{VS_SH}	50	150	300	us	
VS Overvoltage Gain Increase Voltage	V _{OVP}	1.025× V _{AMP}	1.050× V _{AMP}	1.075× V _{AMP}	V	
VS Overvoltage Protection Detection Voltage 1	V _{OVP1}	1.065× V _{AMP}	1.080× V _{AMP}	1.095× V _{AMP}	V	VS rise
VS Overvoltage Protection Detection Voltage 2	V _{OVP2}	1.020× V _{AMP}	1.040× V _{AMP}	1.060× V _{AMP}	V	VS drop
VS Overvoltage Protection Detection Voltage Hys	V _{HYS}	0.030× V _{AMP}	0.040× V _{AMP}	0.050× V _{AMP}	V	
VS Low Voltage Gain Increase Voltage	V _{GUP}	0.840× V _{AMP}	0.900× V _{AMP}	0.960× V _{AMP}	V	
[CS Block]						
CS Threshold Voltage	V _{CS}	0.63	0.65	0.67	V	
Minimum Pulse	H _{min}	-	400	700	ns	CS > V _{CS}
Output Delay	T _{delay}	-	150	300	ns	
[OUT Block]						
OUT H Voltage	V _{POUTH}	10.8	12.0	13.2	V	IO=-20mA
OUT L Voltage	V _{POUTL}	-	-	1.00	V	IO=+20mA
OUT Pull-down Resistance	R _{PDOUT}	75	100	125	kΩ	

Typical Performance Curves

(Reference data)

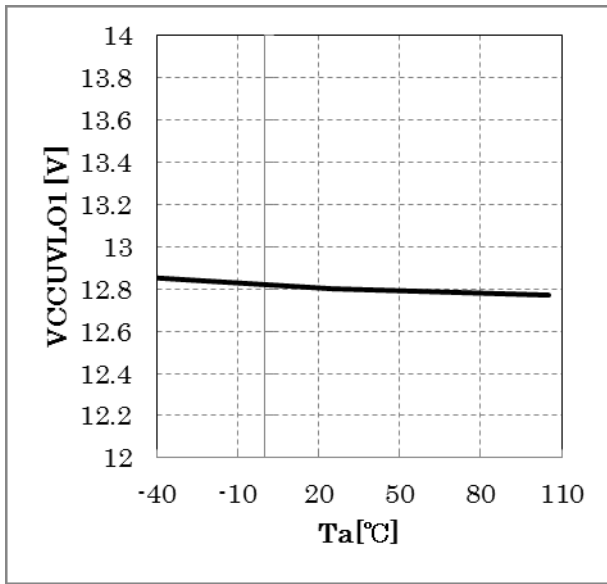

Figure 14. VCC UVLO voltage1 (VCCUVLO1) vs Ambient temperature (Ta)

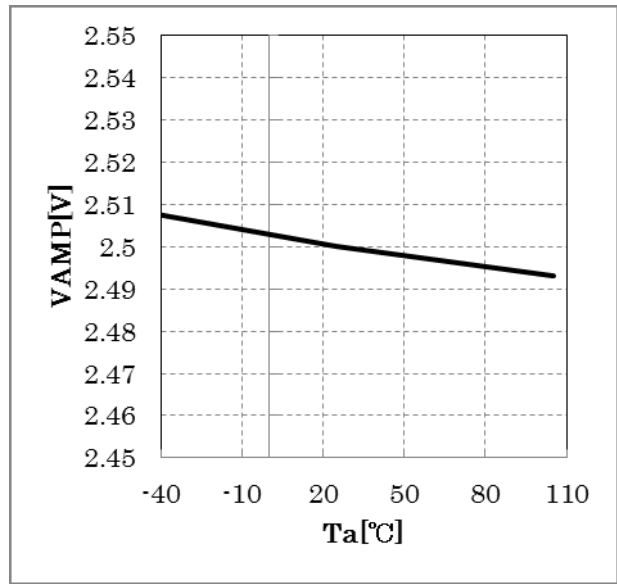

Figure 15. Gm amplifier reference voltage1 (VAMP) vs Ambient temperature (Ta)

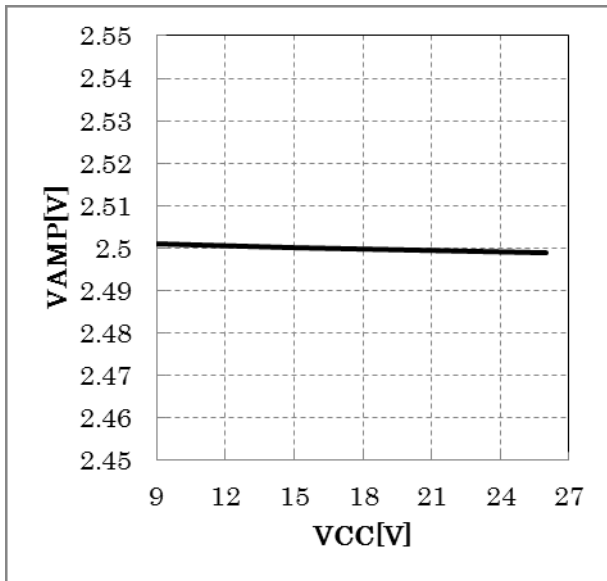

Figure 16. Gm amplifier reference voltage1 (VAMP) vs VCC

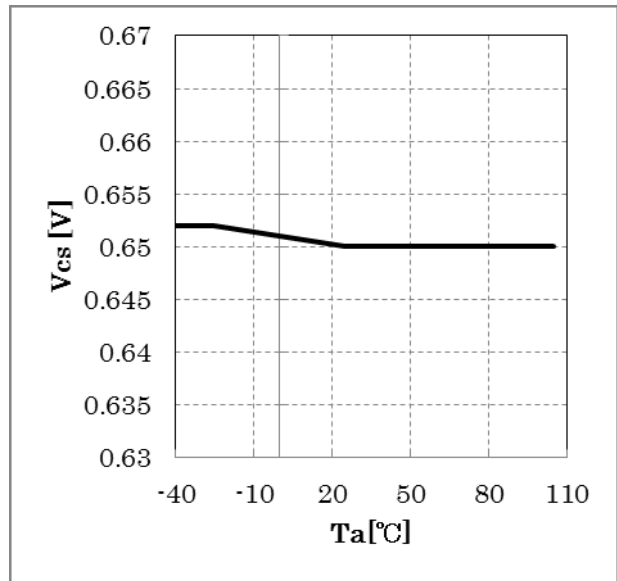

Figure 17. CS threshold voltage (Vcs) vs Ambient temperature (Ta)

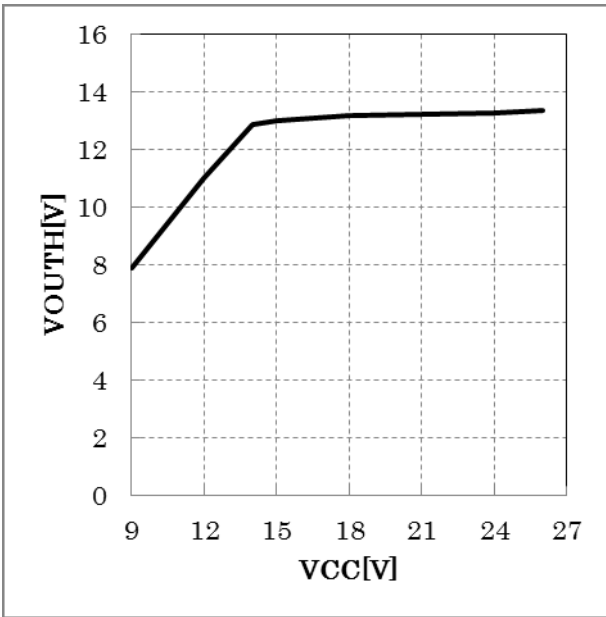

Figure 18. OUT pin H voltage (VOUTH) vs VCC

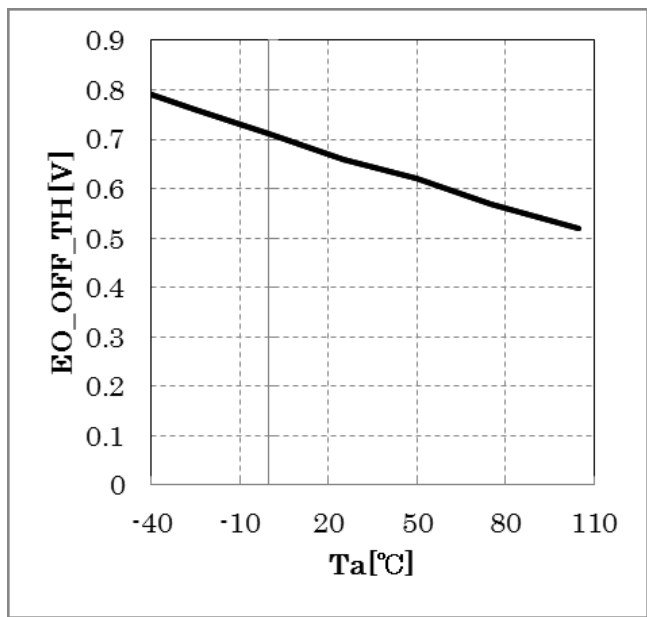

Figure 19. EO pin off threshold (EO_OFF_TH) vs Ambient temperature (Ta)

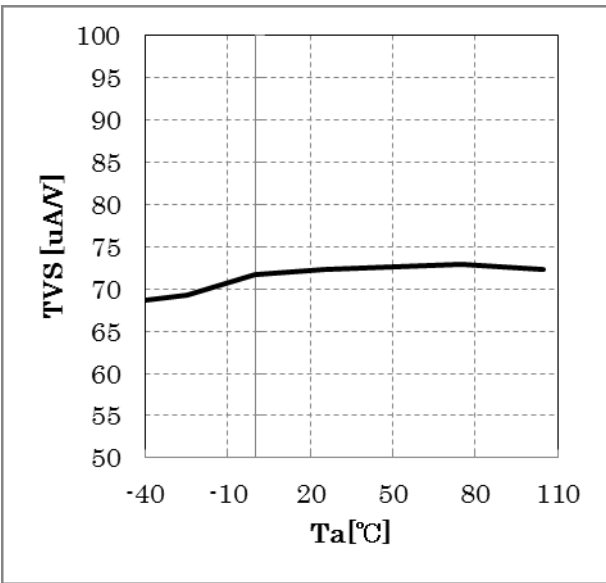

Figure 20. Gm amplifier trans conductance (TVS) vs Ambient temperature (Ta)

I/O Equivalence Circuits

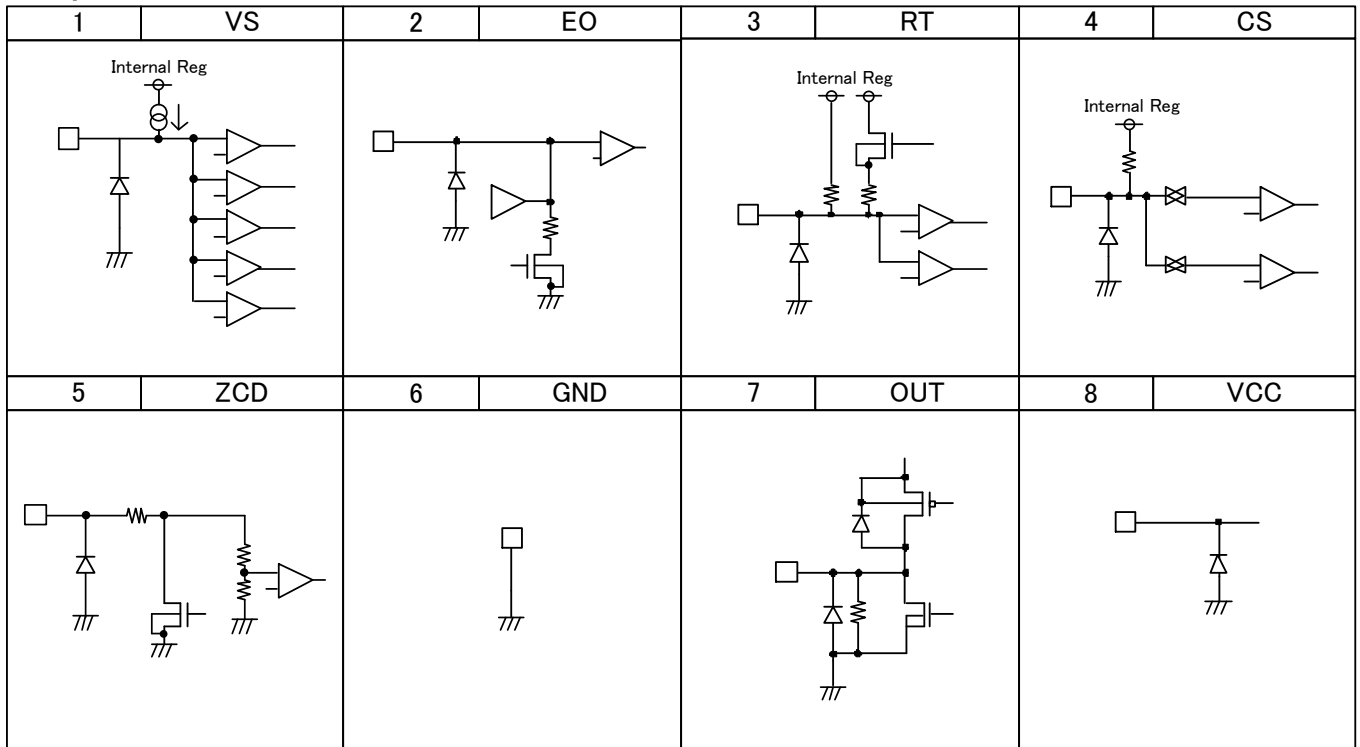

Figure 21. I/O Equivalence Circuits

Application Example

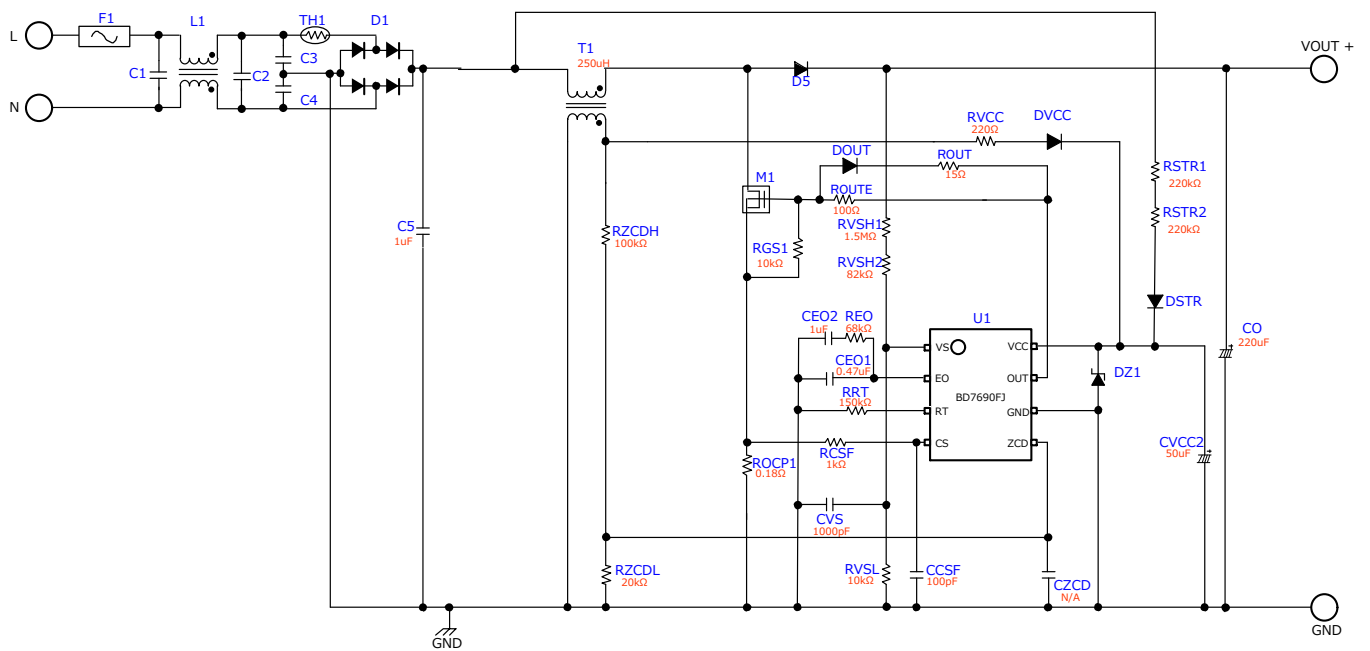

Figure 22. Application Example

1. Output voltage setting

The output voltage is decided in resistor value of RVSH and RVSL.

$$V_{o_PFC} = \left(1 + \frac{RVSH}{RVSL}\right) \times V_{AMP} = \left(1 + \frac{1582k\Omega}{10k\Omega}\right) \times 2.5V = 398V$$

2. Decision of minimum frequency fsw

The switching frequency of PFC

$$f_{sw} = \frac{\eta_{PFC} \times V_{in}^2}{2 \times P_{o_PFC} \times L} \times \frac{V_{o_PFC} - \sqrt{2} \times V_{in}}{V_{o_PFC}}$$

The frequency is minimized in the minimum input voltage. Slow frequency is effective about loss and noise. However, inductance is large value at low frequency. In addition, it enters the audible band when frequency lowers to 20kHz or less, and sound banging occurs. It designs the minimum frequency as 50kHz this time.

3. Calculation of the inductance

$$L = \frac{\eta_{PFC} \times V_{in}^2}{2 \times P_{o_PFC} \times f_{sw}} \times \frac{V_{o_PFC} - \sqrt{2} \times V_{in}}{V_{o_PFC}}$$

Ex) $V_{in} = AC90V$, $V_{o_PFC} = 400V$, $P_{o_PFC} = 200W$, $\eta_{PFC} = 0.9$, $f_{sw} = 50kHz$

$$L = 248.5\mu H \approx 250\mu H$$

4. Calculation of the inductor current

$$I_{pk} = \frac{\sqrt{2} \times V_{in}}{L} \times t_{on} = \frac{2\sqrt{2} \times P_{o_PFC}}{\eta_{PFC} \times V_{in}} = 6.98A$$

5. Calculation of the ON width

$$T_{ON_MAX} [s] = \frac{2 \times L \times P_{o_PFC}}{V_{ACmin}^2 \times \eta_{PFC}}$$

ON width is short at the high AC voltage. Therefore, the ON width is decided with the minimum AC voltage.

It recommends RT setting such as the maximum ON width is just covered at the minimum AC voltage. ON width is small when the high AC voltage. And the EO voltage range is small. EO voltage band width is the large then the ON width setting by the RT resistance is short.

Attention in the board design

About parts placement

Please locate the parts in the Fig.23 inside dot line near the IC. In addition, please do parts placement to avoid the interference with switching lines and high current lines such as inductor, DRAIN.

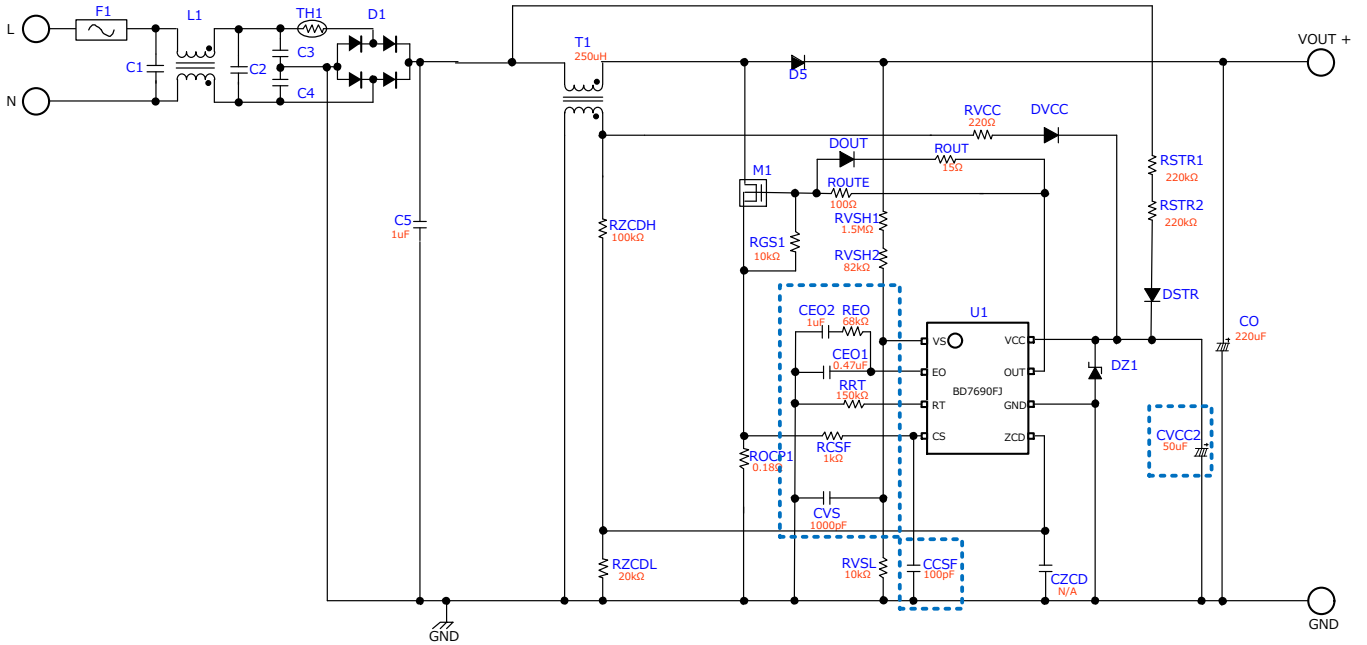

Figure 23. Parts placement

About GND wiring guidance

The red line of Fig.24 becomes the GND lines which large current flows. Each line independence wires it, and please wire it briefly and thickly. A blue line is ICGND. Please make a common use ICGND and GND of IC outskirts parts.

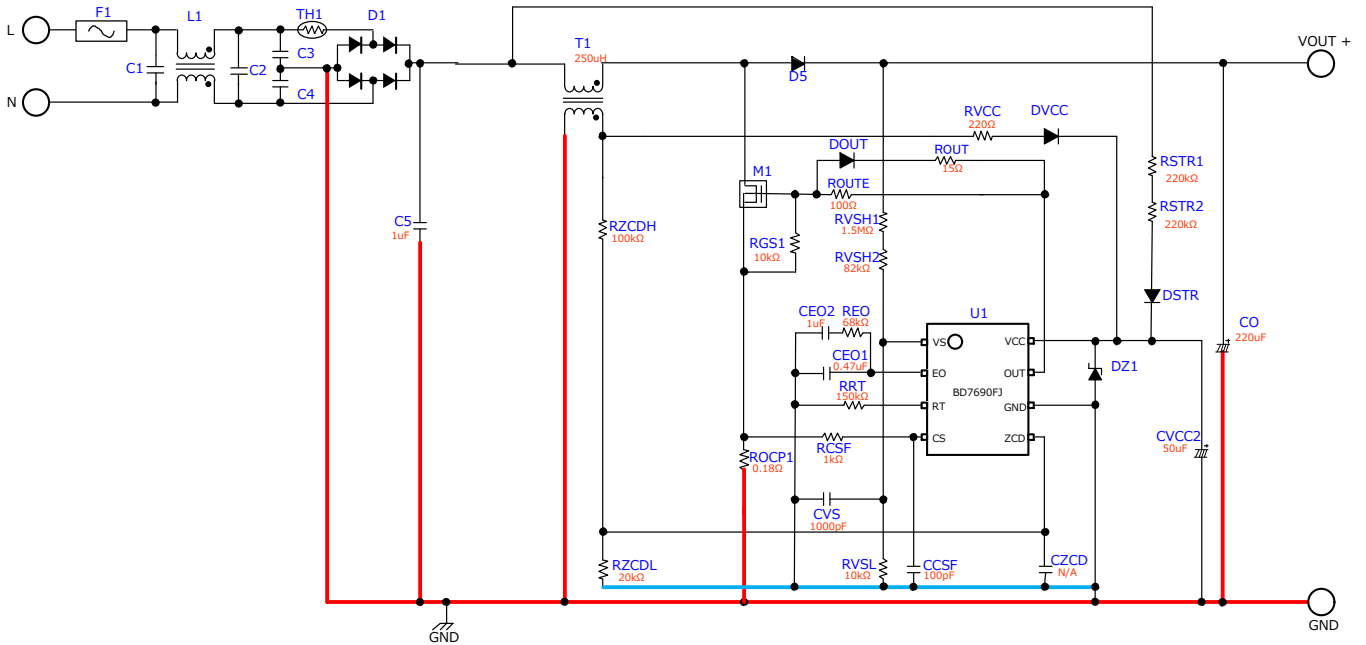

Figure 24. GND line layout

About large current line

Large circuit current flows through the part of the red line of Fig.25. Please wire it briefly and thickly. Please do not place IC and high impedance line near red line. Because red line is very noisy.

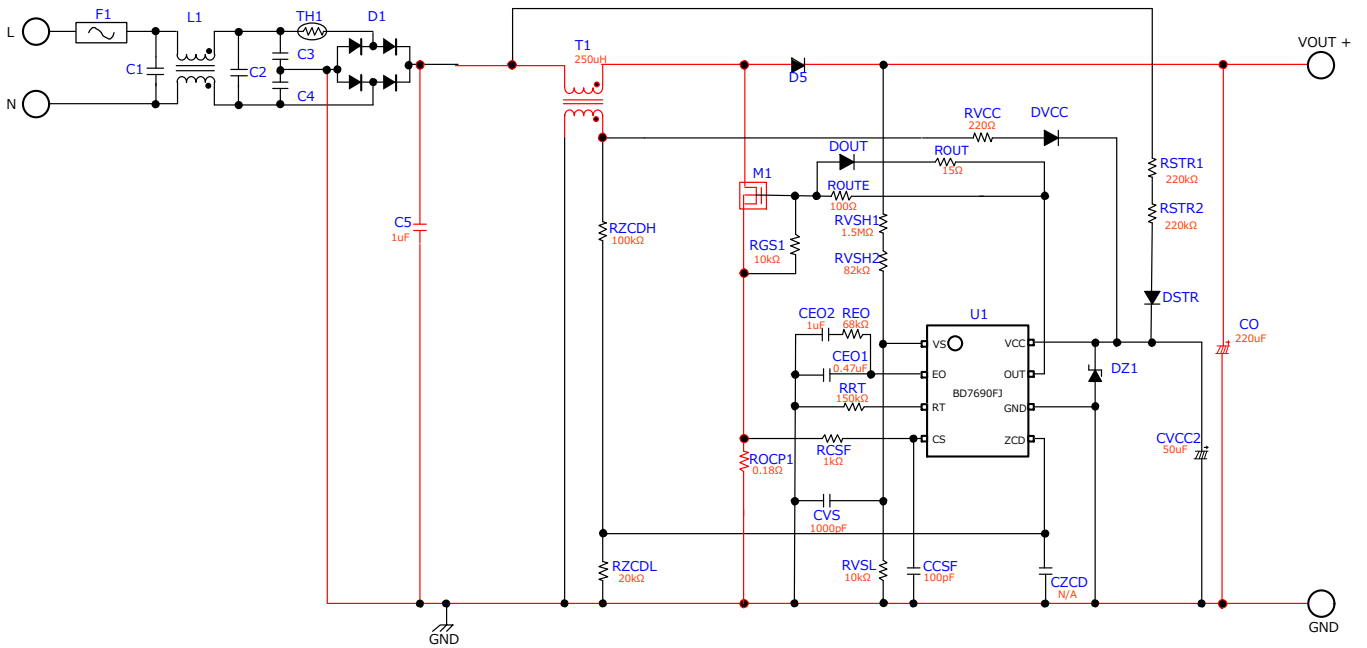

Figure 25. High current line layout

Operational Notes

1. Reverse Connection of Power Supply

Connecting the power supply in reverse polarity can damage the IC. Take precautions against reverse polarity when connecting the power supply, such as mounting an external diode between the power supply and the IC's power supply pins.

2. Power Supply Lines

Design the PCB layout pattern to provide low impedance supply lines. Furthermore, connect a capacitor to ground at all power supply pins. Consider the effect of temperature and aging on the capacitance value when using electrolytic capacitors.

3. Ground Voltage

Except for pins the output and the input of which were designed to go below ground, ensure that no pins are at a voltage below that of the ground pin at any time, even during transient condition.

4. Ground Wiring Pattern

When using both small-signal and large-current ground traces, the two ground traces should be routed separately but connected to a single ground at the reference point of the application board to avoid fluctuations in the small-signal ground caused by large currents. Also ensure that the ground traces of external components do not cause variations on the ground voltage. The ground lines must be as short and thick as possible to reduce line impedance.

5. Thermal Consideration

Should by any chance the maximum junction temperature rating be exceeded the rise in temperature of the chip may result in deterioration of the properties of the chip. In case of exceeding this absolute maximum rating, increase the board size and copper area to prevent exceeding the maximum junction temperature rating.

6. Recommended Operating Conditions

These conditions represent a range within which the expected characteristics of the IC can be approximately obtained. The electrical characteristics are guaranteed under the conditions of each parameter.

7. Inrush Current

When power is first supplied to the IC, it is possible that the internal logic may be unstable and inrush current may flow instantaneously due to the internal powering sequence and delays, especially if the IC has more than one power supply. Therefore, give special consideration to power coupling capacitance, power wiring, width of ground wiring, and routing of connections.

8. Operation Under Strong Electromagnetic Field

Operating the IC in the presence of a strong electromagnetic field may cause the IC to malfunction.

9. Testing on Application Boards

When testing the IC on an application board, connecting a capacitor directly to a low-impedance output pin may subject the IC to stress. Always discharge capacitors completely after each process or step. The IC's power supply should always be turned off completely before connecting or removing it from the test setup during the inspection process. To prevent damage from static discharge, ground the IC during assembly and use similar precautions during transport and storage.

10. Inter-pin Short and Mounting Errors

Ensure that the direction and position are correct when mounting the IC on the PCB. Incorrect mounting may result in damaging the IC. Avoid nearby pins being shorted to each other especially to ground, power supply and output pin. Inter-pin shorts could be due to many reasons such as metal particles, water droplets (in very humid environment) and unintentional solder bridge deposited in between pins during assembly to name a few.

11. Unused Input Pins

Input pins of an IC are often connected to the gate of a MOS transistor. The gate has extremely high impedance and extremely low capacitance. If left unconnected, the electric field from the outside can easily charge it. The small charge acquired in this way is enough to produce a significant effect on the conduction through the transistor and cause unexpected operation of the IC. So unless otherwise specified, unused input pins should be connected to the power supply or ground line.

12. Regarding the Input Pin of the IC

This monolithic IC contains P+ isolation and P substrate layers between adjacent elements in order to keep them isolated. P-N junctions are formed at the intersection of the P layers with the N layers of other elements, creating a parasitic diode or transistor. For example (refer to figure below):

When $GND > Pin A$ and $GND > Pin B$, the P-N junction operates as a parasitic diode.
When $GND > Pin B$, the P-N junction operates as a parasitic transistor.

Parasitic diodes inevitably occur in the structure of the IC. The operation of parasitic diodes can result in mutual interference among circuits, operational faults, or physical damage. Therefore, conditions that cause these diodes to operate, such as applying a voltage lower than the GND voltage to an input pin (and thus to the P substrate) should be avoided.

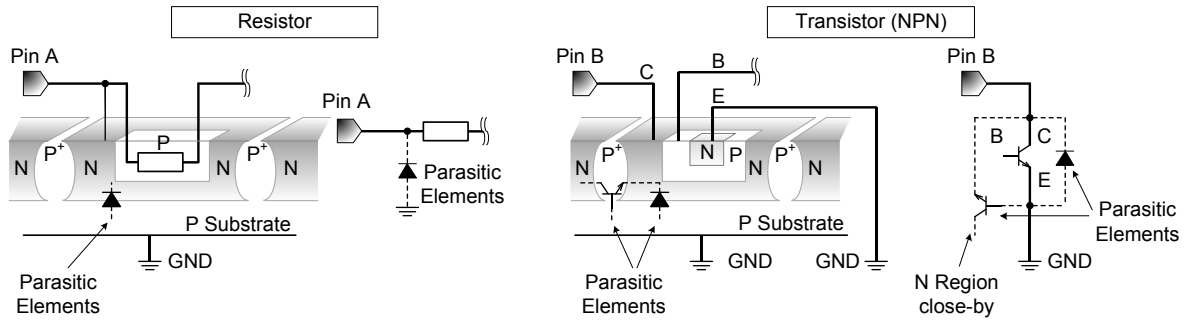

Figure xx. Example of monolithic IC structure

13. Ceramic Capacitor

When using a ceramic capacitor, determine a capacitance value considering the change of capacitance with temperature and the decrease in nominal capacitance due to DC bias and others.

14. Area of Safe Operation (ASO)

Operate the IC such that the output voltage, output current, and the maximum junction temperature rating are all within the Area of Safe Operation (ASO).

15. Thermal Shutdown Circuit(TSD)

This IC has a built-in thermal shutdown circuit that prevents heat damage to the IC. Normal operation should always be within the IC's maximum junction temperature rating. If however the rating is exceeded for a continued period, the junction temperature (T_j) will rise which will activate the TSD circuit that will turn OFF all output pins. When the T_j falls below the TSD threshold, the circuits are automatically restored to normal operation.

Note that the TSD circuit operates in a situation that exceeds the absolute maximum ratings and therefore, under no circumstances, should the TSD circuit be used in a set design or for any purpose other than protecting the IC from heat damage.

16. Over Current Protection Circuit (OCP)

This IC incorporates an integrated overcurrent protection circuit that is activated when the load is shorted. This protection circuit is effective in preventing damage due to sudden and unexpected incidents. However, the IC should not be used in applications characterized by continuous operation or transitioning of the protection circuit.

17. Disturbance light

In a device where a portion of silicon is exposed to light such as in a WL-CSP, IC characteristics may be affected due to photoelectric effect. For this reason, it is recommended to come up with countermeasures that will prevent the chip from being exposed to light.

Ordering Information

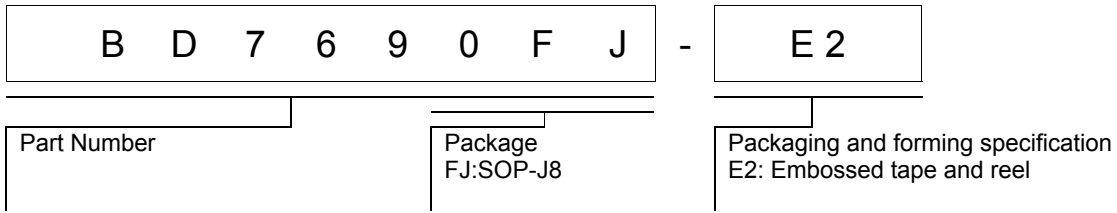

Marking Diagrams

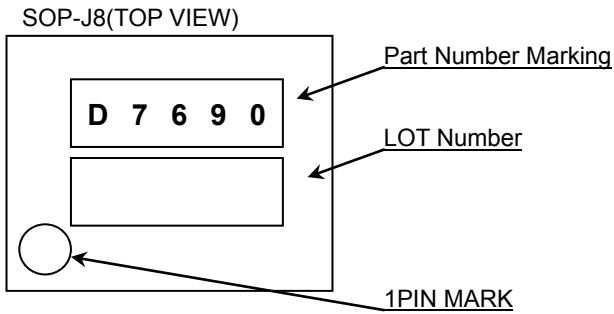

Part Number Marking	Package	Orderable Part Number
D7690	SOP-J8	BD7690FJ-E2

Physical Dimension, Tape and Reel Information

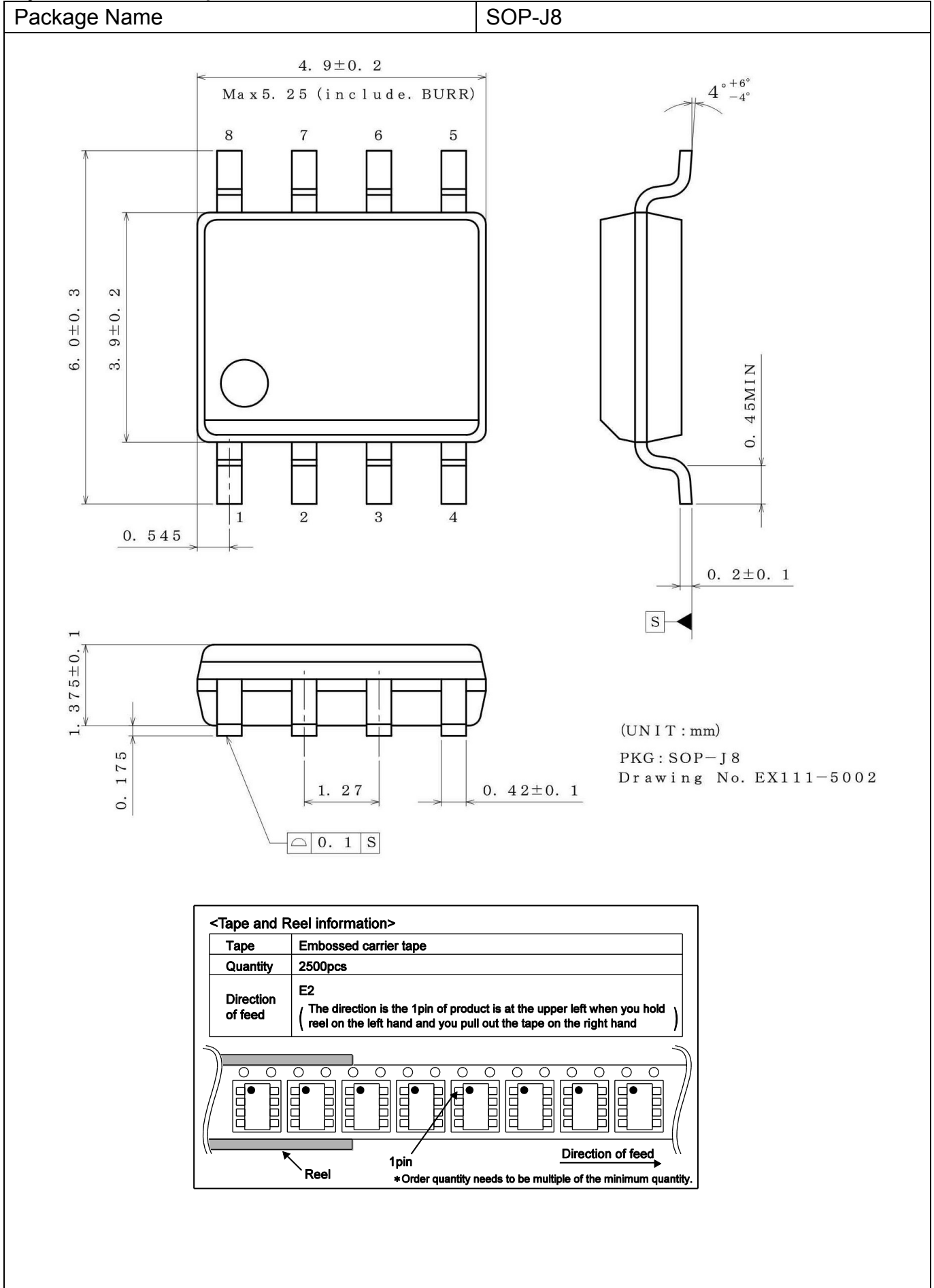

Revision History

Date	Revision	Changes
23. Jan. 2017	001	Release
27. Mar. 2017	002	p.11 Add electrical characteristics

Notice

Precaution on using ROHM Products

- Our Products are designed and manufactured for application in ordinary electronic equipments (such as AV equipment, OA equipment, telecommunication equipment, home electronic appliances, amusement equipment, etc.). If you intend to use our Products in devices requiring extremely high reliability (such as medical equipment ^(Note 1), transport equipment, traffic equipment, aircraft/spacecraft, nuclear power controllers, fuel controllers, car equipment including car accessories, safety devices, etc.) and whose malfunction or failure may cause loss of human life, bodily injury or serious damage to property ("Specific Applications"), please consult with the ROHM sales representative in advance. Unless otherwise agreed in writing by ROHM in advance, ROHM shall not be in any way responsible or liable for any damages, expenses or losses incurred by you or third parties arising from the use of any ROHM's Products for Specific Applications.

(Note1) Medical Equipment Classification of the Specific Applications

JAPAN	USA	EU	CHINA
CLASS III	CLASS III	CLASS II b	CLASS III
CLASS IV		CLASS III	

- ROHM designs and manufactures its Products subject to strict quality control system. However, semiconductor products can fail or malfunction at a certain rate. Please be sure to implement, at your own responsibilities, adequate safety measures including but not limited to fail-safe design against the physical injury, damage to any property, which a failure or malfunction of our Products may cause. The following are examples of safety measures:
 - Installation of protection circuits or other protective devices to improve system safety
 - Installation of redundant circuits to reduce the impact of single or multiple circuit failure
- Our Products are designed and manufactured for use under standard conditions and not under any special or extraordinary environments or conditions, as exemplified below. Accordingly, ROHM shall not be in any way responsible or liable for any damages, expenses or losses arising from the use of any ROHM's Products under any special or extraordinary environments or conditions. If you intend to use our Products under any special or extraordinary environments or conditions (as exemplified below), your independent verification and confirmation of product performance, reliability, etc. prior to use, must be necessary:
 - Use of our Products in any types of liquid, including water, oils, chemicals, and organic solvents
 - Use of our Products outdoors or in places where the Products are exposed to direct sunlight or dust
 - Use of our Products in places where the Products are exposed to sea wind or corrosive gases, including Cl₂, H₂S, NH₃, SO₂, and NO₂
 - Use of our Products in places where the Products are exposed to static electricity or electromagnetic waves
 - Use of our Products in proximity to heat-producing components, plastic cords, or other flammable items
 - Sealing or coating our Products with resin or other coating materials
 - Use of our Products without cleaning residue of flux (even if you use no-clean type fluxes, cleaning residue of flux is recommended); or Washing our Products by using water or water-soluble cleaning agents for cleaning residue after soldering
 - Use of the Products in places subject to dew condensation
- The Products are not subject to radiation-proof design.
- Please verify and confirm characteristics of the final or mounted products in using the Products.
- In particular, if a transient load (a large amount of load applied in a short period of time, such as pulse. is applied, confirmation of performance characteristics after on-board mounting is strongly recommended. Avoid applying power exceeding normal rated power; exceeding the power rating under steady-state loading condition may negatively affect product performance and reliability.
- De-rate Power Dissipation depending on ambient temperature. When used in sealed area, confirm that it is the use in the range that does not exceed the maximum junction temperature.
- Confirm that operation temperature is within the specified range described in the product specification.
- ROHM shall not be in any way responsible or liable for failure induced under deviant condition from what is defined in this document.

Precaution for Mounting / Circuit board design

- When a highly active halogenous (chlorine, bromine, etc.) flux is used, the residue of flux may negatively affect product performance and reliability.
- In principle, the reflow soldering method must be used on a surface-mount products, the flow soldering method must be used on a through hole mount products. If the flow soldering method is preferred on a surface-mount products, please consult with the ROHM representative in advance.

For details, please refer to ROHM Mounting specification

Precautions Regarding Application Examples and External Circuits

1. If change is made to the constant of an external circuit, please allow a sufficient margin considering variations of the characteristics of the Products and external components, including transient characteristics, as well as static characteristics.
2. You agree that application notes, reference designs, and associated data and information contained in this document are presented only as guidance for Products use. Therefore, in case you use such information, you are solely responsible for it and you must exercise your own independent verification and judgment in the use of such information contained in this document. ROHM shall not be in any way responsible or liable for any damages, expenses or losses incurred by you or third parties arising from the use of such information.

Precaution for Electrostatic

This Product is electrostatic sensitive product, which may be damaged due to electrostatic discharge. Please take proper caution in your manufacturing process and storage so that voltage exceeding the Products maximum rating will not be applied to Products. Please take special care under dry condition (e.g. Grounding of human body / equipment / solder iron, isolation from charged objects, setting of ionizer, friction prevention and temperature / humidity control).

Precaution for Storage / Transportation

1. Product performance and soldered connections may deteriorate if the Products are stored in the places where:
 - [a] the Products are exposed to sea winds or corrosive gases, including Cl₂, H₂S, NH₃, SO₂, and NO₂
 - [b] the temperature or humidity exceeds those recommended by ROHM
 - [c] the Products are exposed to direct sunshine or condensation
 - [d] the Products are exposed to high Electrostatic
2. Even under ROHM recommended storage condition, solderability of products out of recommended storage time period may be degraded. It is strongly recommended to confirm solderability before using Products of which storage time is exceeding the recommended storage time period.
3. Store / transport cartons in the correct direction, which is indicated on a carton with a symbol. Otherwise bent leads may occur due to excessive stress applied when dropping of a carton.
4. Use Products within the specified time after opening a humidity barrier bag. Baking is required before using Products of which storage time is exceeding the recommended storage time period.

Precaution for Product Label

A two-dimensional barcode printed on ROHM Products label is for ROHM's internal use only.

Precaution for Disposition

When disposing Products please dispose them properly using an authorized industry waste company.

Precaution for Foreign Exchange and Foreign Trade act

Since concerned goods might be fallen under listed items of export control prescribed by Foreign exchange and Foreign trade act, please consult with ROHM in case of export.

Precaution Regarding Intellectual Property Rights

1. All information and data including but not limited to application example contained in this document is for reference only. ROHM does not warrant that foregoing information or data will not infringe any intellectual property rights or any other rights of any third party regarding such information or data.
2. ROHM shall not have any obligations where the claims, actions or demands arising from the combination of the Products with other articles such as components, circuits, systems or external equipment (including software).
3. No license, expressly or implied, is granted hereby under any intellectual property rights or other rights of ROHM or any third parties with respect to the Products or the information contained in this document. Provided, however, that ROHM will not assert its intellectual property rights or other rights against you or your customers to the extent necessary to manufacture or sell products containing the Products, subject to the terms and conditions herein.

Other Precaution

1. This document may not be reprinted or reproduced, in whole or in part, without prior written consent of ROHM.
2. The Products may not be disassembled, converted, modified, reproduced or otherwise changed without prior written consent of ROHM.
3. In no event shall you use in any way whatsoever the Products and the related technical information contained in the Products or this document for any military purposes, including but not limited to, the development of mass-destruction weapons.
4. The proper names of companies or products described in this document are trademarks or registered trademarks of ROHM, its affiliated companies or third parties.

General Precaution

1. Before you use our Products, you are requested to carefully read this document and fully understand its contents. ROHM shall not be in any way responsible or liable for failure, malfunction or accident arising from the use of any ROHM's Products against warning, caution or note contained in this document.
2. All information contained in this document is current as of the issuing date and subject to change without any prior notice. Before purchasing or using ROHM's Products, please confirm the latest information with a ROHM sales representative.
3. The information contained in this document is provided on an "as is" basis and ROHM does not warrant that all information contained in this document is accurate and/or error-free. ROHM shall not be in any way responsible or liable for any damages, expenses or losses incurred by you or third parties resulting from inaccuracy or errors of or concerning such information.